

947-045 Bulkhead Feed-Thru, Jam Nut Mount MIL-DTL-5015 Type

HOW TO ORDER:

EXAMPLE: 947-045 M 18 - 11 P X

BASIC NO _____

FINISH SYM, TABLE II _____

SHELL SIZE, TABLE I _____

INSERT ARRANGEMENT
PER MIL-C-5015 _____

P = PIN/PIN
S = SOCKET/SOCKET
OMIT INSERT DASH NO FOR PIN/SOCKET

ALTERNATE POSITION _____

W,X,Y,Z (OMIT FOR NORMAL)

SEE MIL-DTL-5015 FOR
INSERT ARRANGEMENTS

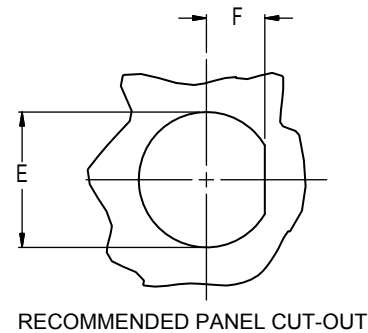
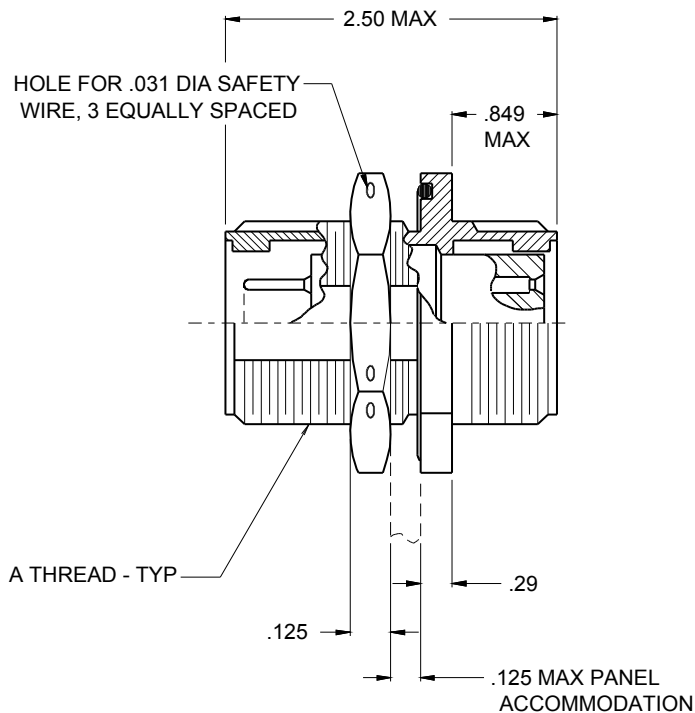
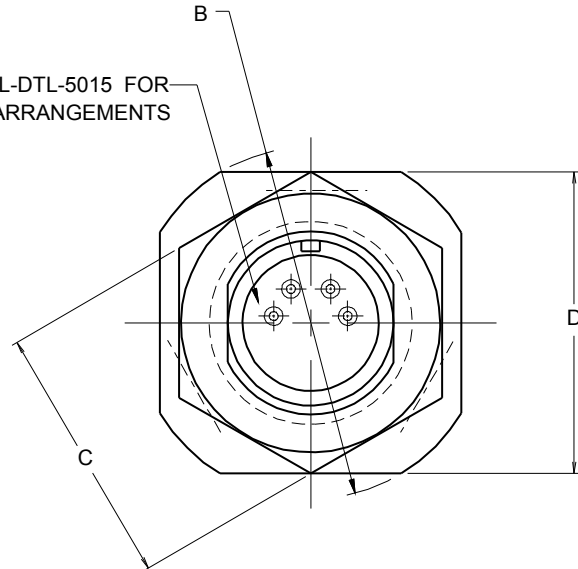

NOTES:

1. ASSEMBLY IDENTIFIED WITH MANUFACTURER'S NAME AND P/N, SPACE PERMITTING.
2. MATERIAL/FINISH:
JAM NUT, HOODS, LOCKRING, SHELL ASSEMBLY - AL ALLOY/SEE TABLE II
CONTACTS - ALLOY 52/GOLD PLATE
INSULATORS - HIGH-GRADE RIGID DIELECTRIC
O-RINGS & SEALS - SILICONE/N.A.