

ASSP Mobile Communication Systems

Piezoelectric SAW BPF

(700 to 1700MHz)

F5CP/F6CP Series (D2 type)

■ DESCRIPTION

The F5CP/F6CP series of SAW band pass filters have 2.5 mm × 2.0 mm × 0.9 mm (h) of ultra small package, which are available in the 700 to 2000 MHz frequency range. They exhibit high stability by using single crystal, Lithium Tantalate (LiTaO₃) with a large electro-mechanical coefficient.

Typical applications for the F5CP/F6CP series include RF interstage filtering in mobile communications systems. Standard devices are available for AMPS, GSM, EGSM, PDC800, PDC1.5G.

■ FEATURES

- Ultra compact and light package (2.5 mm × 2.0 mm × 0.9 mm (h) *)
*: 1.0 mm height maximum
- Excellent stop band attenuation
- External matching are not required (50 Ω I/O)
- Standard devices are available for mobile communication standards

■ PACKAGE

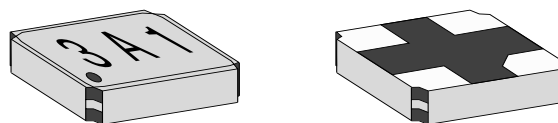

F5CP/F6CP Series

■ PIN ASSIGNMENT

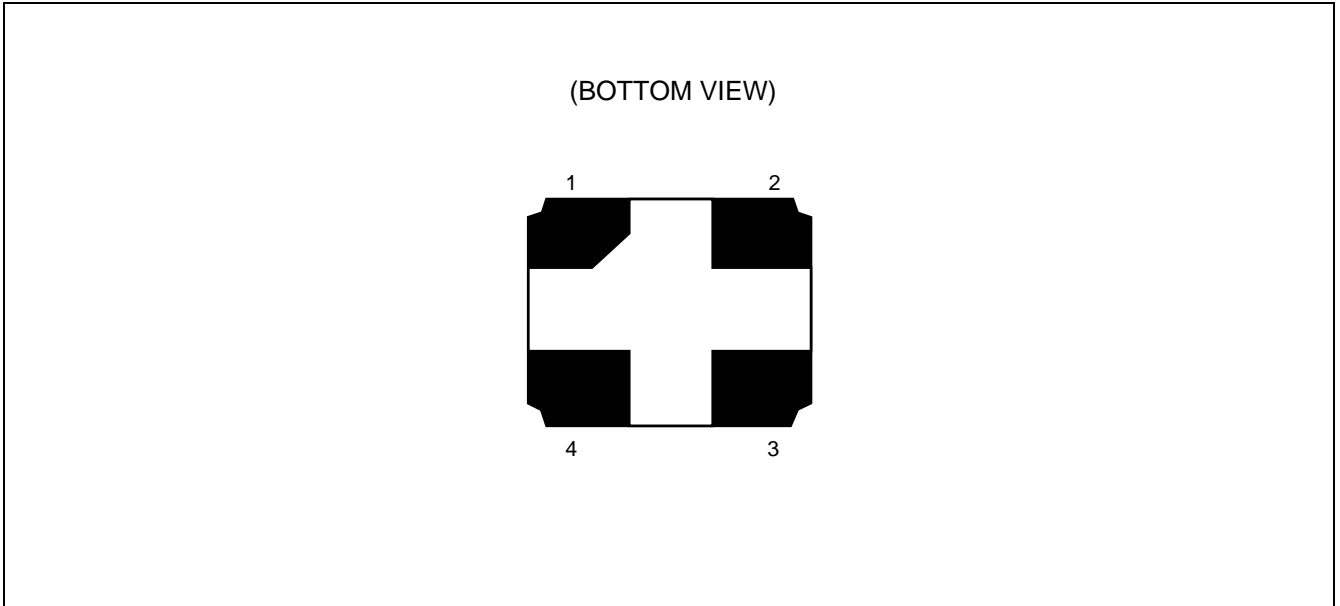

■ PIN DESCRIPTION

Pin No.	Symbol	Descriptions
1	IN	Input pin
2	GND	Ground pin
3	OUT	Output pin
4	GND	Ground pin

F5CP/F6CP Series

■ ABSOLUTE MAXIMUM RATINGS

Parameter	Symbol	Rating		Unit
		Min.	Max.	
Ambient operating temperature	Ta	-30	+85	°C
Storage temperature	Tstg	-40	+100	°C
Input power	F5CP Series	—	+15	dBm
	F6CP Series	—	+10	dBm
Input DC voltage	—	-5	+5	V

WARNING: Piezoelectric devices can be permanently damaged by application of stress (voltage, current, temperature, etc.) in excess of absolute maximum ratings. Do not exceed these ratings.

■ RECOMMENDED OPERATING CONDITIONS

Parameter	Symbol	Value		Unit
		Min.	Max.	
Operating temperature	Ta	-30	+85	°C

WARNING: The recommended operating conditions are required in order to ensure the normal operation of the piezoelectric device. All of the device's electrical characteristics are warranted when the device is operated within these ranges.

Always use piezoelectric devices within their recommended operating condition ranges. Operation outside these ranges may adversely affect reliability and could result in device failure.

No warranty is made with respect to uses, operating conditions, or combinations not represented on the data sheet. Users considering application outside the listed conditions are advised to contact their FUJITSU representatives beforehand.

■ STANDARD DEVICES

System		Center frequency (MHz)	Bandwidth (MHz)	Part symbol	Part number	Re-remarks
PDC800	Tx	950.0	20	9	FAR-F5CP-950M00-D209	
	Rx	820.0	20	2	FAR-F5CP-820M00-D202	
AMPS/CDMA/TDMA	Tx	836.5	25	3	FAR-F5CP-836M50-D203	
	Rx	881.5	25	4	FAR-F5CP-881M50-D204	
GSM	Tx	902.5	25	5	FAR-F5CP-902M50-D205	
	Rx	947.5	25	6	FAR-F5CP-947M50-D206	
EGSM	Rx	942.5	35	1	FAR-F5CP-942M50-D201	
PDC1.5G	Tx	1441.0	24	7	FAR-F6CP-1G4410-D207	
	Rx	1489.0	24	8	FAR-F6CP-1G4890-D208	

F5CP/F6CP Series

■ ELECTRICAL CHARACTERISTICS AND TYPICAL FREQUENCY RESPONSE

1. SYSTEM : PDC800-Tx

PART NUMBER : FAR-F5CP-950M00-D209

Parameter	Conditions	Value			Unit	Remarks
		Min.	Typ.	Max.		
Insertion loss	940 to 960 MHz	—	3.1	3.5	dB	
In-band ripple	940 to 960 MHz	—	0.8	1.2	dB	
Absolute attenuation	DC to 830 MHz	45	52	—	dB	
	1015 to 1106 MHz	35	42	—	dB	
	1106 to 1700 MHz	45	55	—	dB	
	1700 to 2000 MHz	40	48	—	dB	
In-band VSWR (Return loss)	940 to 960 MHz	— (8.1)	2.1 (9.0)	2.3 (—)	— (dB)	

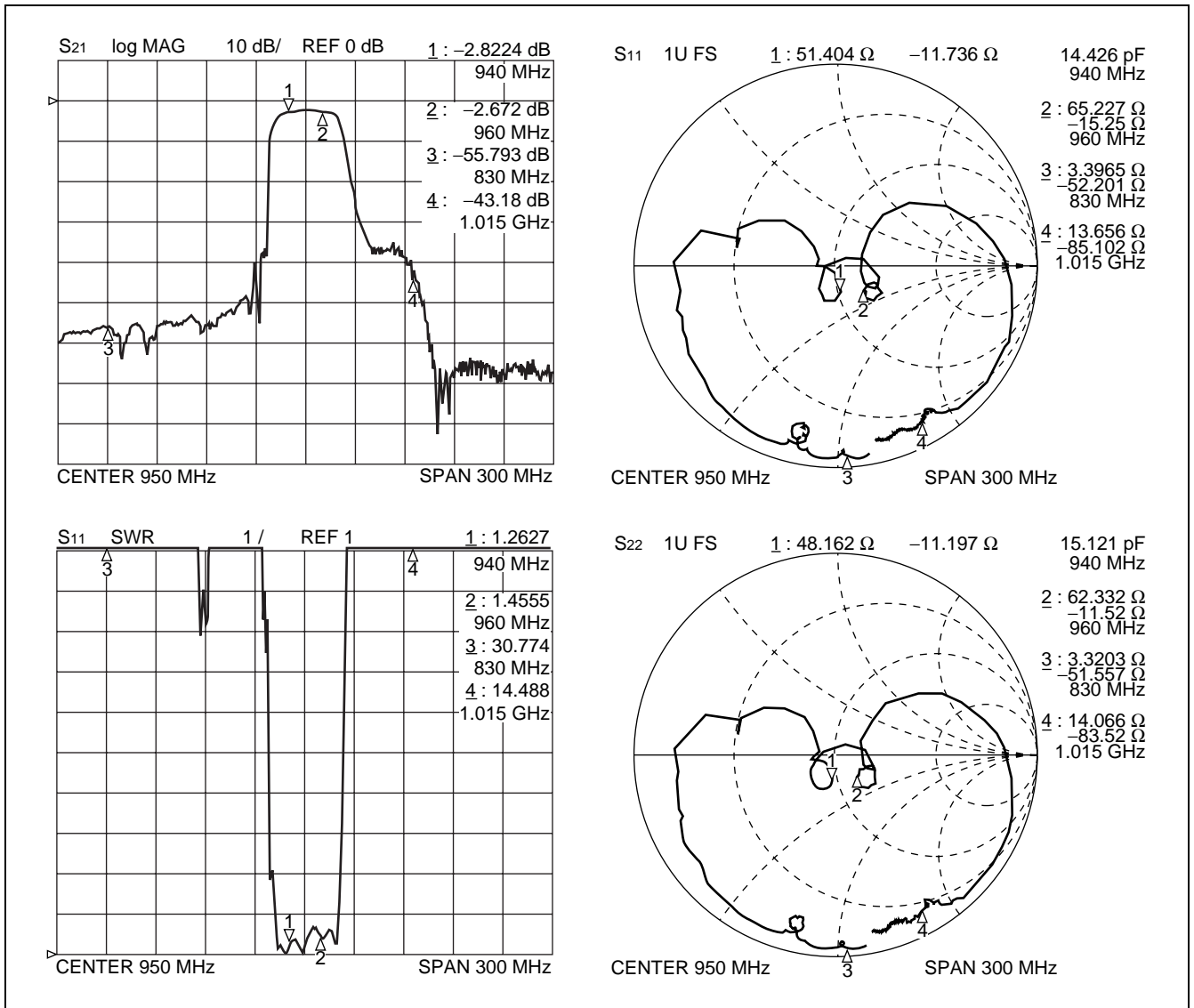

F5CP/F6CP Series

2. PDC800-Rx

PART NUMBER : FAR-F5CP-820M00-D202

Parameter	Conditions	Value			Unit	Remarks
		Min.	Typ.	Max.		
Insertion loss	810 to 830 MHz	—	2.6	3.3	dB	
In-band ripple	810 to 830 MHz	—	0.8	1.5	dB	
Absolute attenuation	DC to 760 MHz	45	52	—	dB	
	855 to 875 MHz	28	30	—	dB	
	875 to 920 MHz	35	38	—	dB	
	920 to 1200 MHz	45	55	—	dB	
	1200 to 2000 MHz	40	47	—	dB	
In-band VSWR (Return loss)	810 to 830 MHz	— (8.5)	2.0 (9.5)	2.2 (—)	— (dB)	

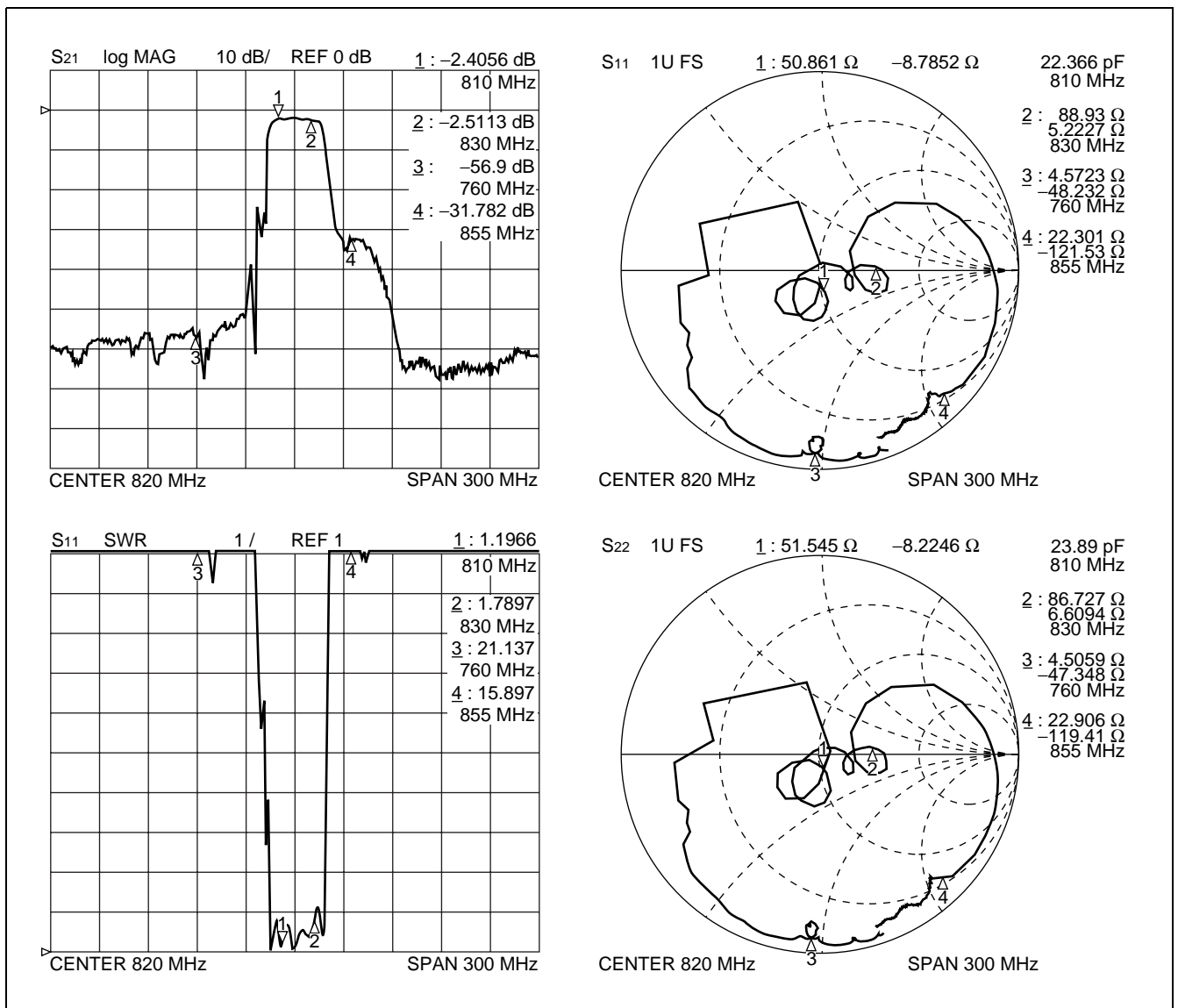

F5CP/F6CP Series

3. SYSTEM : AMPS-Tx

PART NUMBER : FAR-F5CP-836M50-D203

Parameter	Conditions	Value			Unit	Remarks
		Min.	Typ.	Max.		
Insertion loss	824 to 849 MHz	—	3.0	3.5	dB	
In-band ripple	824 to 849 MHz	—	1.1	1.6	dB	
Absolute attenuation	DC to 800 MHz	45	50	—	dB	
	869 to 1049 MHz	29	35	—	dB	
	1049 to 2000 MHz	45	50	—	dB	
In-band VSWR (Return loss)	824 to 849 MHz	— (8.5)	1.9 (10.2)	2.2 (—)	— (dB)	

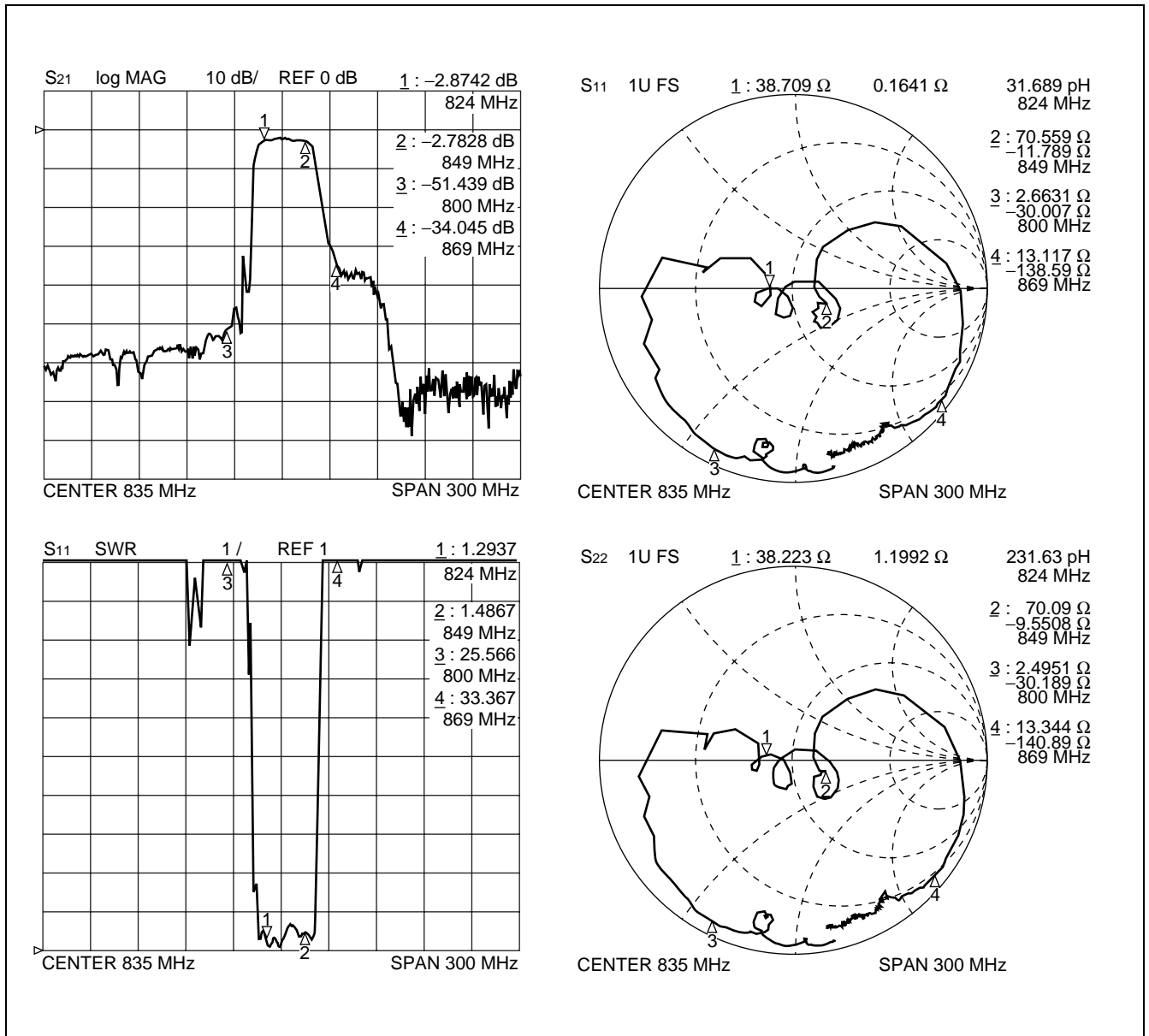

F5CP/F6CP Series

4. SYSTEM : AMPS-Rx

PART NUMBER : FAR-F5CP-881M50-D204

Parameter	Conditions	Value			Unit	Remarks
		Min.	Typ.	Max.		
Insertion loss	869 to 894 MHz	—	2.9	3.5	dB	
In-band ripple	869 to 894 MHz	—	1.0	1.6	dB	
Absolute attenuation	DC to 779 MHz	45	50	—	dB	
	779 to 849 MHz	40	47	—	dB	
	914 to 970 MHz	28	33	—	dB	
	970 to 1049 MHz	50	60	—	dB	
	1049 to 2000 MHz	40	50	—	dB	
In-band VSWR (Return loss)	869 to 894 MHz	— (8.5)	1.9 (10.2)	2.2 (—)	— (dB)	

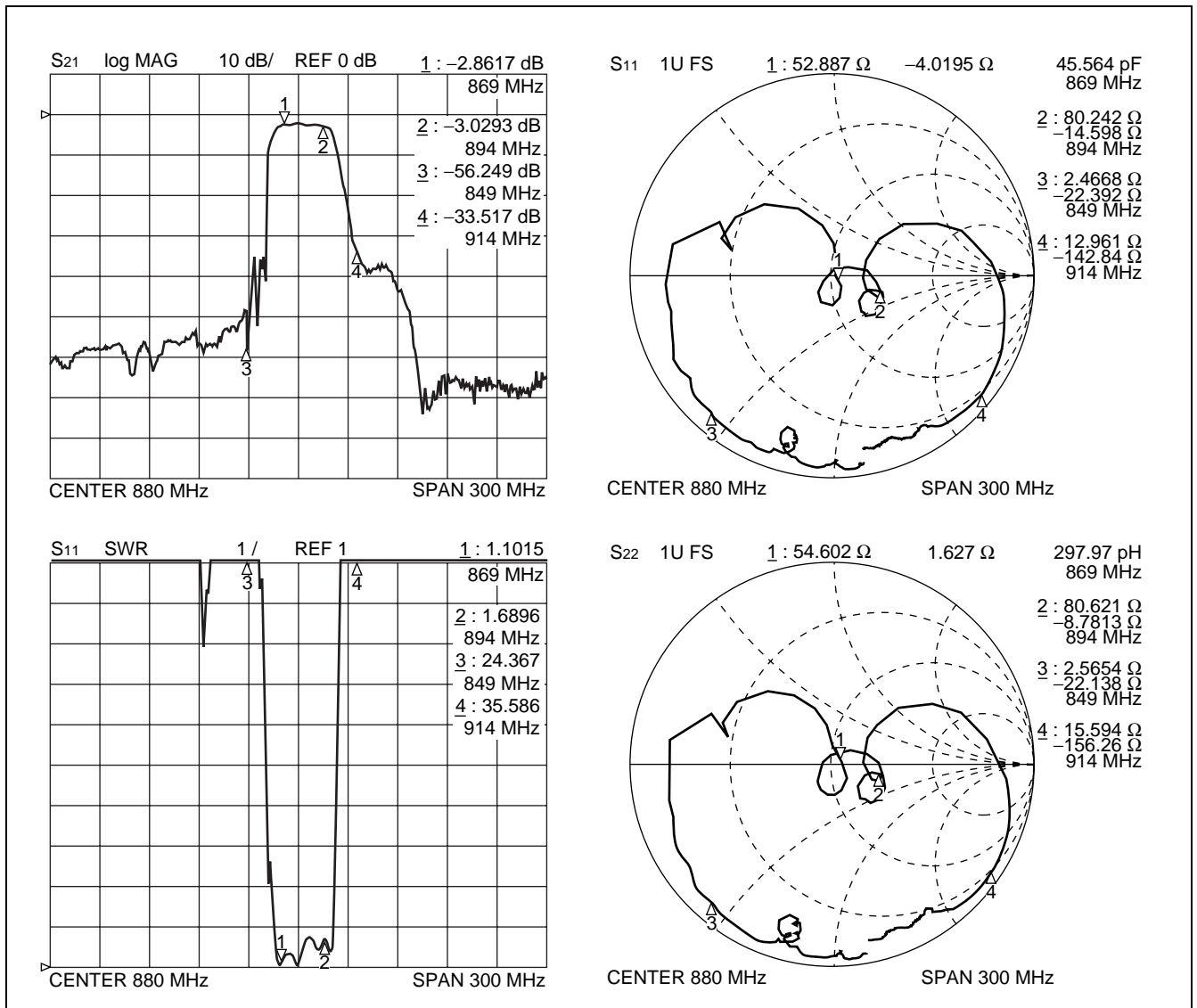

F5CP/F6CP Series

5. SYSTEM : GSM-Tx

PART NUMBER : FAR-F5CP-902M50-D205

Parameter	Conditions	Value			Unit	Remarks
		Min.	Typ.	Max.		
Insertion loss	890 to 915 MHz	—	3.0	3.5	dB	
In-band ripple	890 to 915 MHz	—	1.1	1.6	dB	
Absolute attenuation	DC to 845 MHz	45	50	—	dB	
	845 to 870 MHz	30	46	—	dB	
	925 to 935 MHz	7	16	—	dB	
	935 to 980 MHz	28	33	—	dB	
	980 to 1200 MHz	50	60	—	dB	
In-Band VSWR (Return loss)	890 to 915 MHz	—	1.7	2.1	—	
		(9.0)	(11.7)	(—)	(dB)	

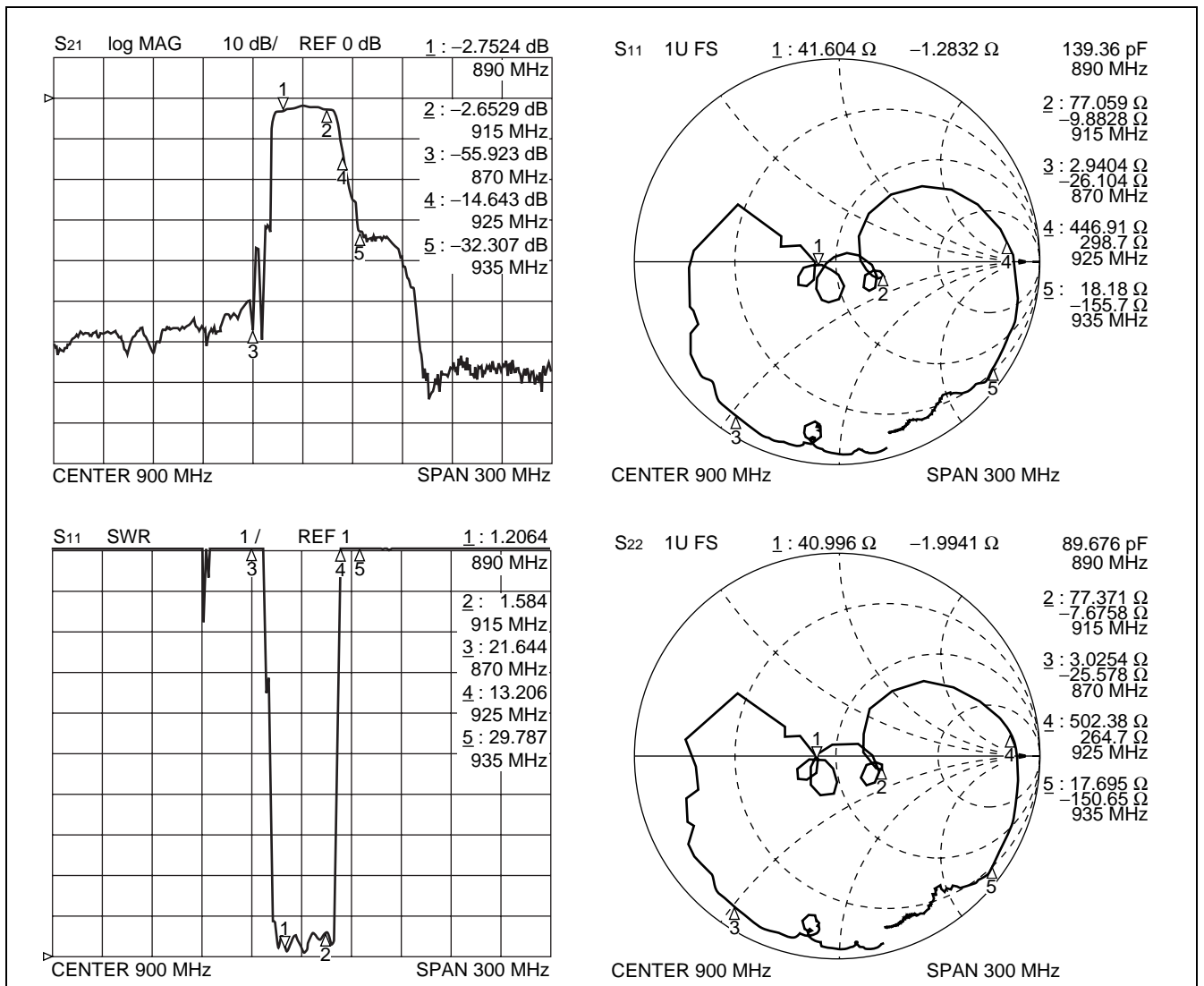

F5CP/F6CP Series

6. SYSTEM : GSM-Rx

PART NUMBER : FAR-F5CP-947M50-D206

Parameter	Conditions	Value			Unit	Remarks
		Min.	Typ.	Max.		
Insertion loss	935 to 960 MHz	—	3.1	3.5	dB	
In-band ripple	935 to 960 MHz	—	1.3	1.5	dB	
Absolute attenuation	DC to 871 MHz	45	50	—	dB	
	890 to 915 MHz	30	45	—	dB	
	980 to 1025 MHz	25	30	—	dB	
	1025 to 2000 MHz	45	48	—	dB	
	2000 to 3000 MHz	30	33	—	dB	
In-band VSWR (Return loss)	935 to 960 MHz	— (8.1)	2.1 (9.0)	2.3 (—)	— (dB)	

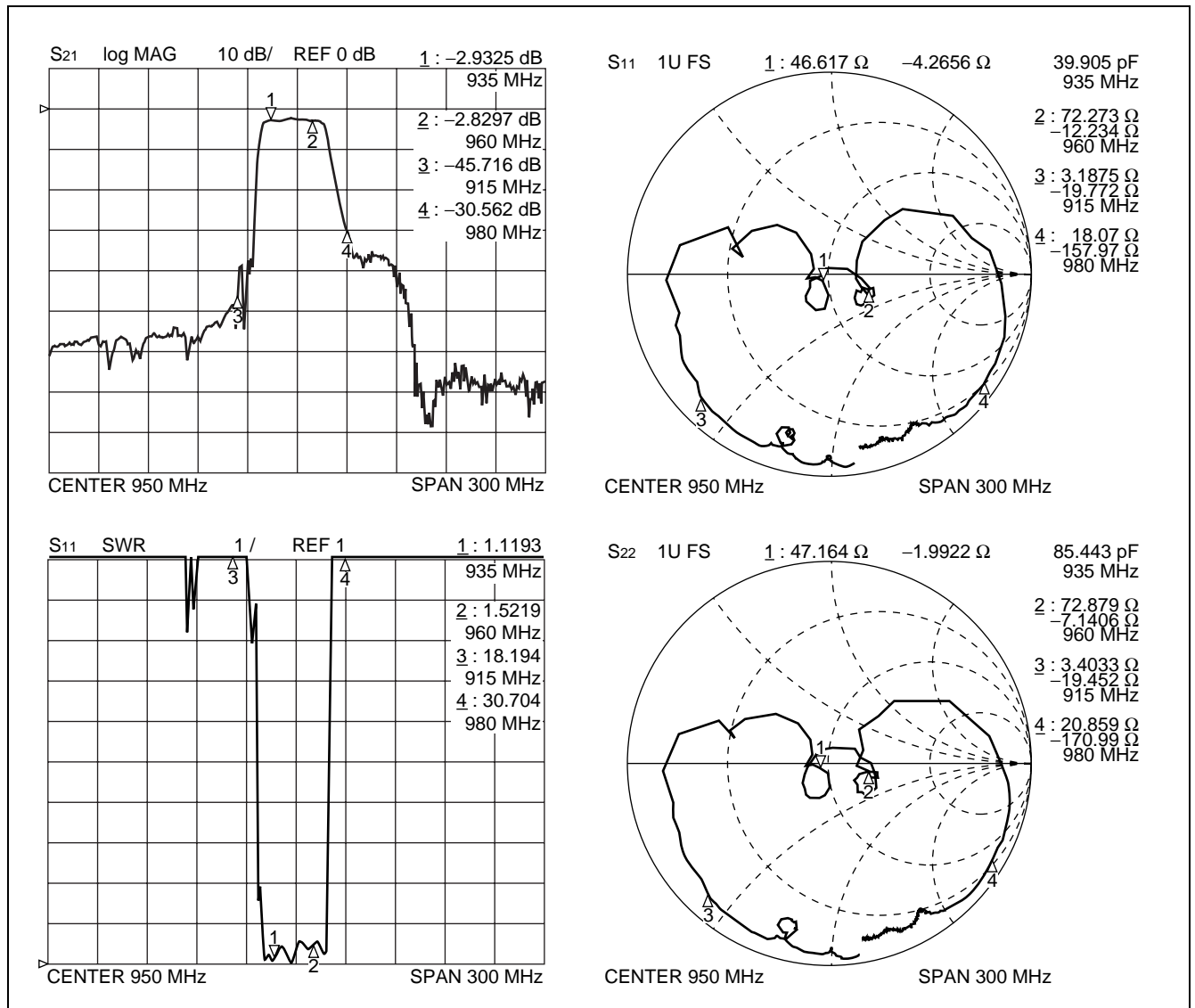

F5CP/F6CP Series

7. SYSTEM : EGSM-Rx

PART NUMBER : FAR-F5CP-942M50-D201

Parameter	Conditions	Value			Unit	Remarks
		Min.	Typ.	Max.		
Insertion loss	925 to 960 MHz	—	3.9	4.8	dB	
In-band ripple	925 to 960 MHz	—	2.0	2.9	dB	
Absolute attenuation	DC to 871 MHz	45	53	—	dB	
	890 to 915 MHz	15	20	—	dB	
	980 to 1025 MHz	25	29	—	dB	
	1025 to 2000 MHz	40	50	—	dB	
	2000 to 3000 MHz	25	36	—	dB	
In-band VSWR (Return loss)	925 to 960 MHz	— (6.0)	2.4 (7.7)	3.0 (—)	— (dB)	

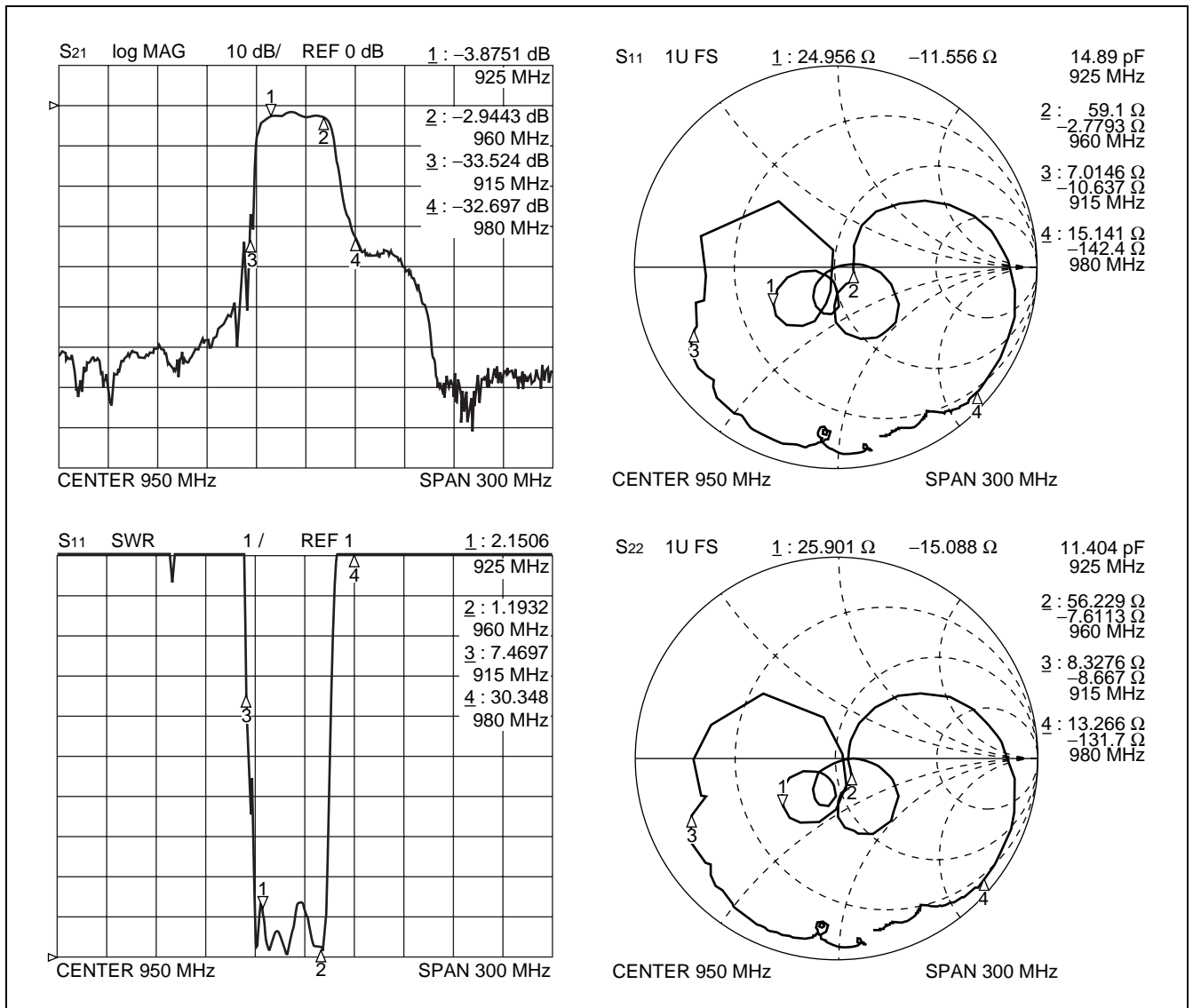

F5CP/F6CP Series

8. SYSTEM : PDC1.5G-Tx

PART NUMBER : FAR-F6CP-1G4410-D207

Parameter	Conditions	Value			Unit	Remarks
		Min.	Typ.	Max.		
Insertion loss	1429 to 1453 MHz	—	3.5	3.8	dB	
In-band ripple	1429 to 1453 MHz	—	1.3	1.6	dB	
Absolute attenuation	DC to 1380 MHz	40	45	—	dB	
	1477 to 1501 MHz	25	28	—	dB	
	1501 to 1607 MHz	28	30	—	dB	
	1607 to 1900 MHz	45	55	—	dB	
	1900 to 3000 MHz	30	33	—	dB	
In-band VSWR (Return loss)	1429 to 1453 MHz	— (7.0)	2.4 (7.7)	2.6 (—)	— (dB)	

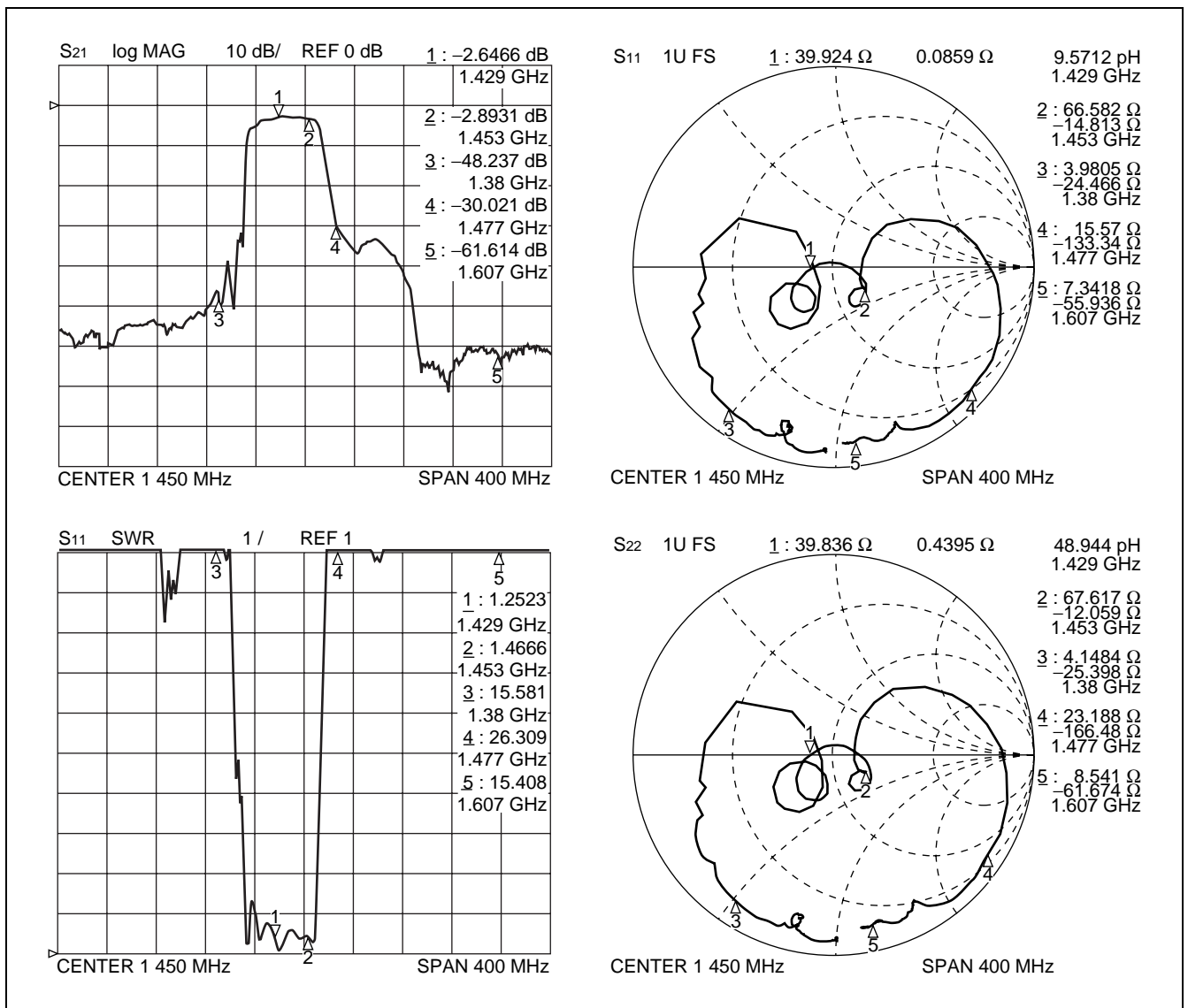

F5CP/F6CP Series

9. SYSTEM : PDC1.5G-Rx

PART NUMBER : FAR-F6CP-1G4890-D208

Parameter	Conditions	Value			Unit	Remarks
		Min.	Typ.	Max.		
Insertion loss	1477 to 1501 MHz	—	3.6	4.0	dB	
In-band ripple	1477 to 1501 MHz	—	1.3	1.7	dB	
Absolute attenuation	DC to 1370 MHz	45	50	—	dB	
	1370 to 1429 MHz	40	45	—	dB	
	1429 to 1453 MHz	15	30	—	dB	
	1542 to 1566 MHz	28	30	—	dB	
	1566 to 1607 MHz	28	30	—	dB	
	1607 to 1900 MHz	40	45	—	dB	
In-band VSWR (Return loss)	1477 to 1501 MHz	—	2.5	2.7	—	
		(6.8)	(7.4)	(—)	(dB)	

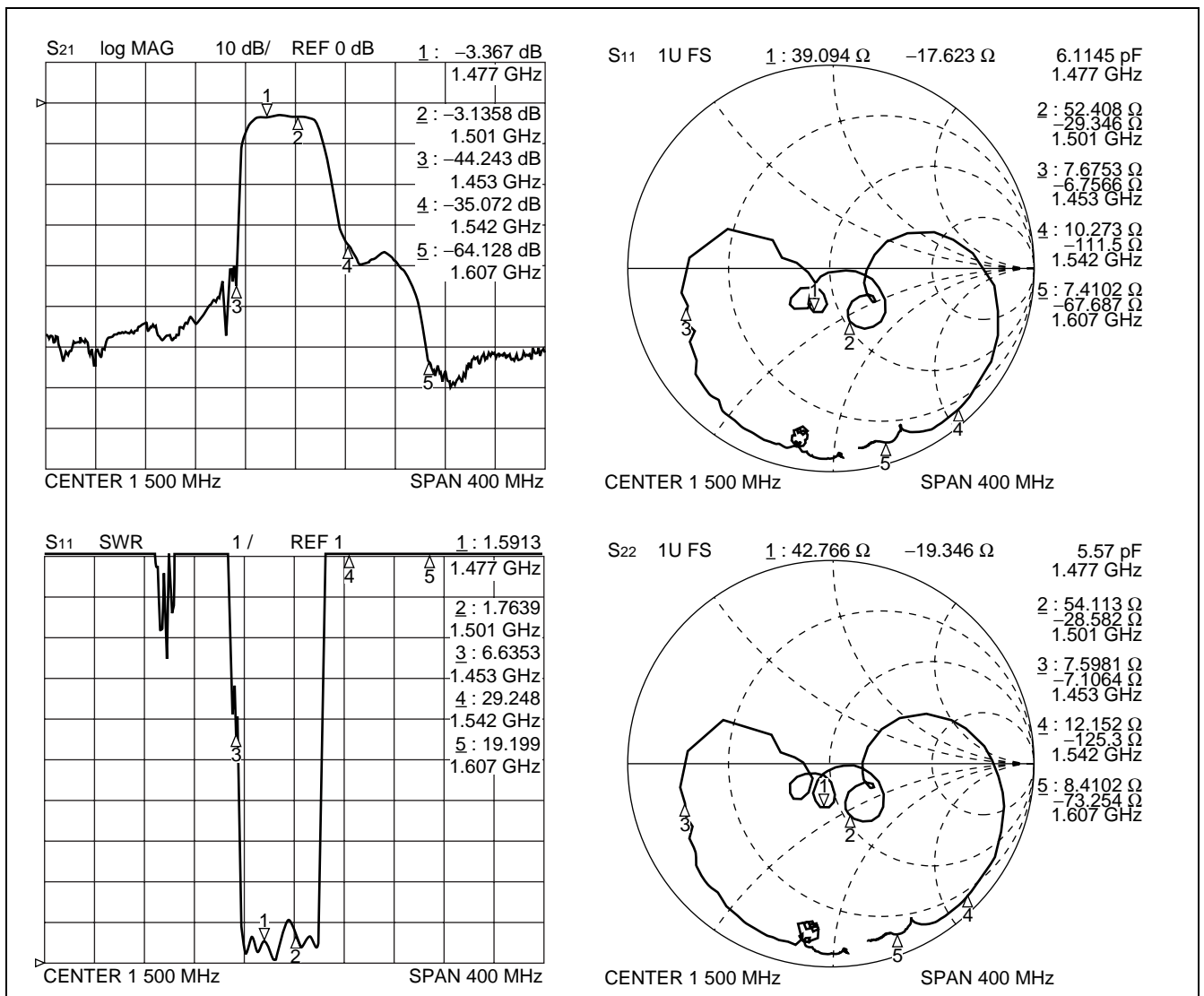

F5CP/F6CP Series

MEASUREMENT CIRCUIT

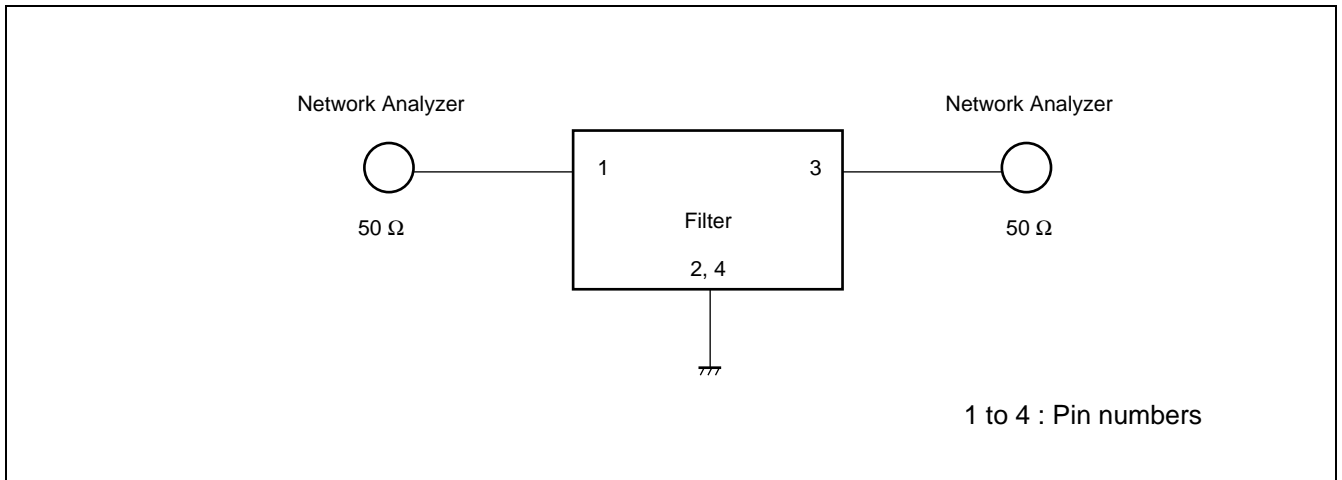

PART NUMBER DESIGNATION

[Designation example]

FAR-F5CP-□□□□□□-D2□□-□
 (1) (2) (3) (4) (5)

- (1) Frequency range
 - 5 : 700 to 1000 MHz
 - 6 : 1000 to 1700 MHz
- (2) Package size
 - P : 2.5 mm × 2.0 mm × 0.9 mm
- (3) Frequency
 - This specifies the nominal center frequency using six alphanumeric.
 - M (for MHz) or G (for GHz) indicates the decimal point.
 - [Example] 836.5 MHz → 836M50
 - 1.441 GHz → 1G4410
- (4) Part symbol
 - Numbers specified by Fujitsu
 - Refer to STANDARD DEVICES
- (5) Packing (Reeled tape)
 - W : 1000 pcs / reel
 - V : 3000 pcs / reel
 - U : 5000 pcs / reel

MARKING

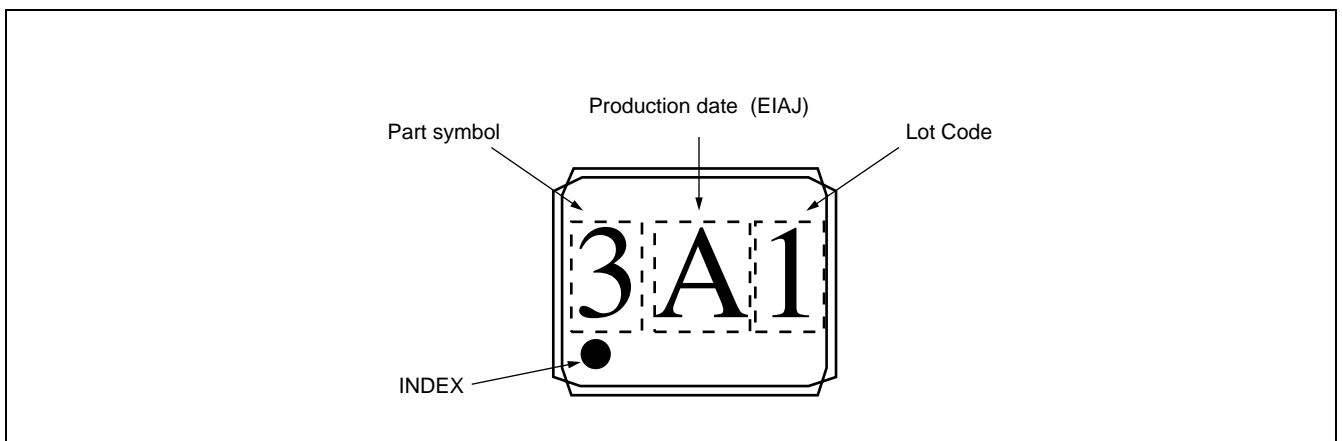

F5CP/F6CP Series

■ PACKAGE DIMENSIONS

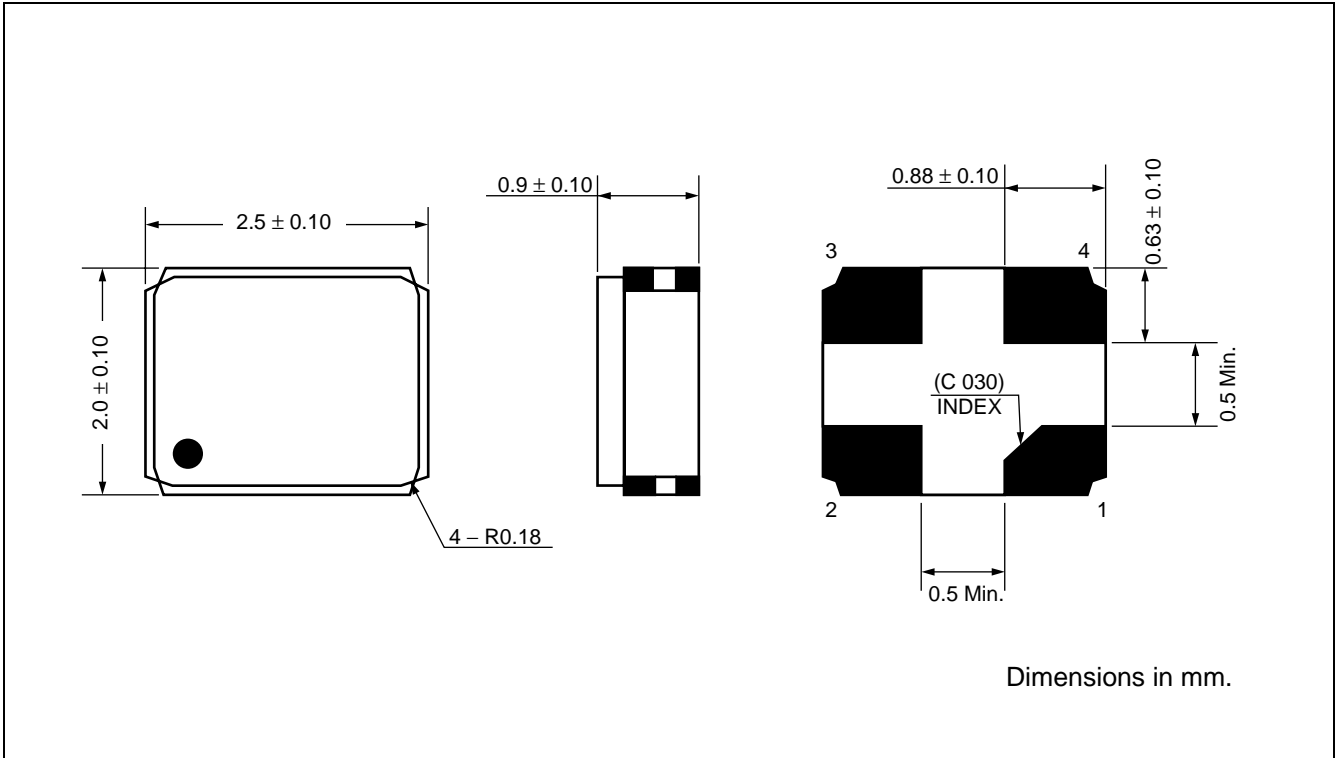

■ RECOMMENDED FOOT PATTERN ON PCB

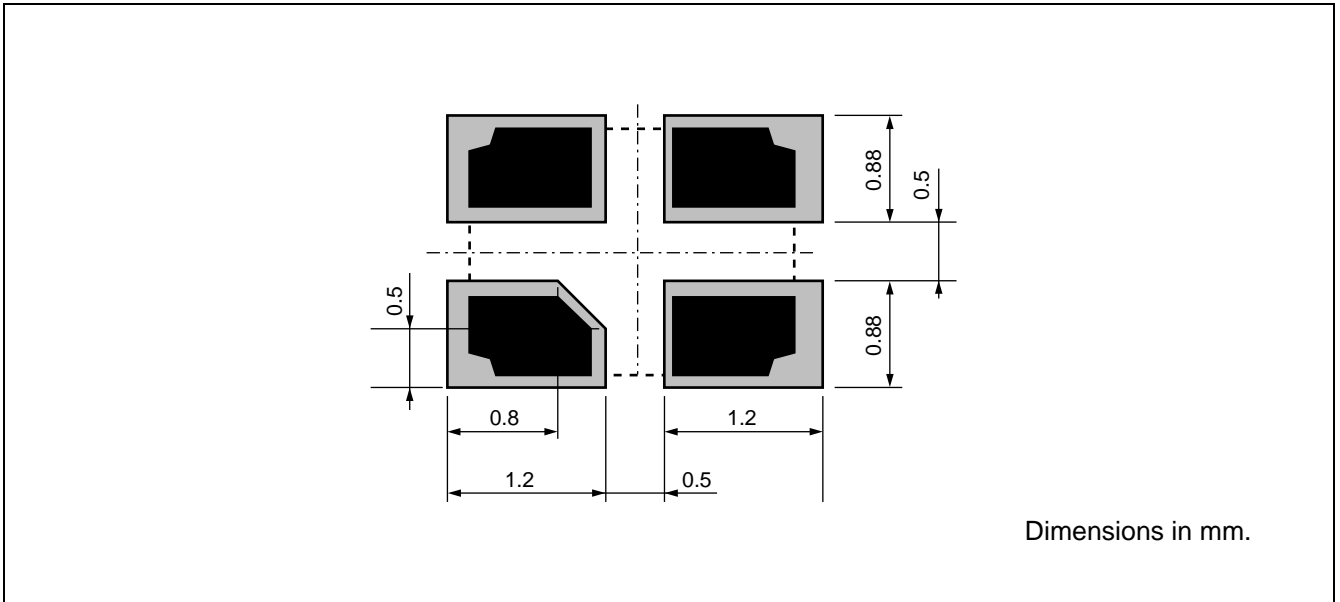

F5CP/F6CP Series

PACKING

(1) Reel dimensions

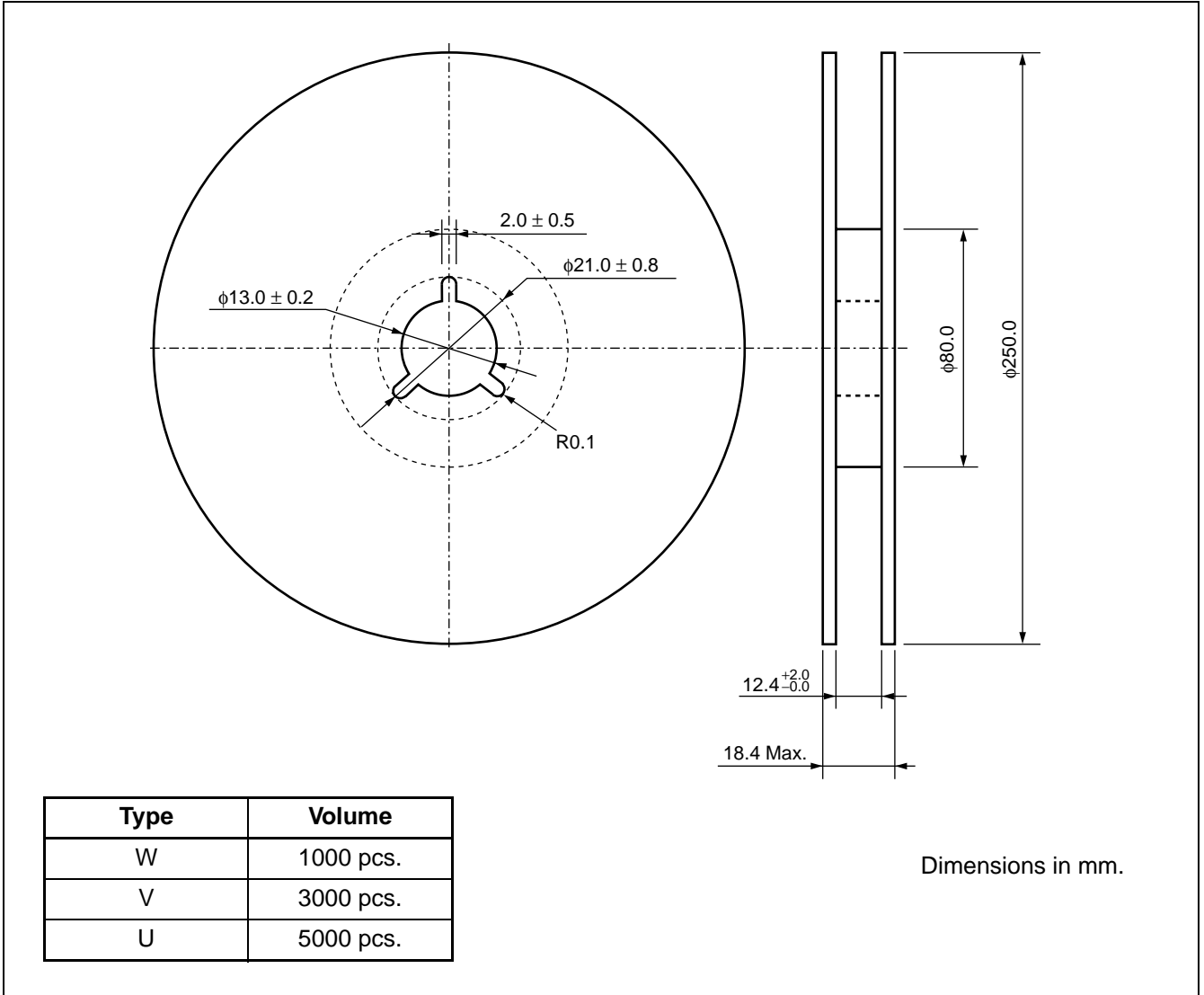

(2) Packing style

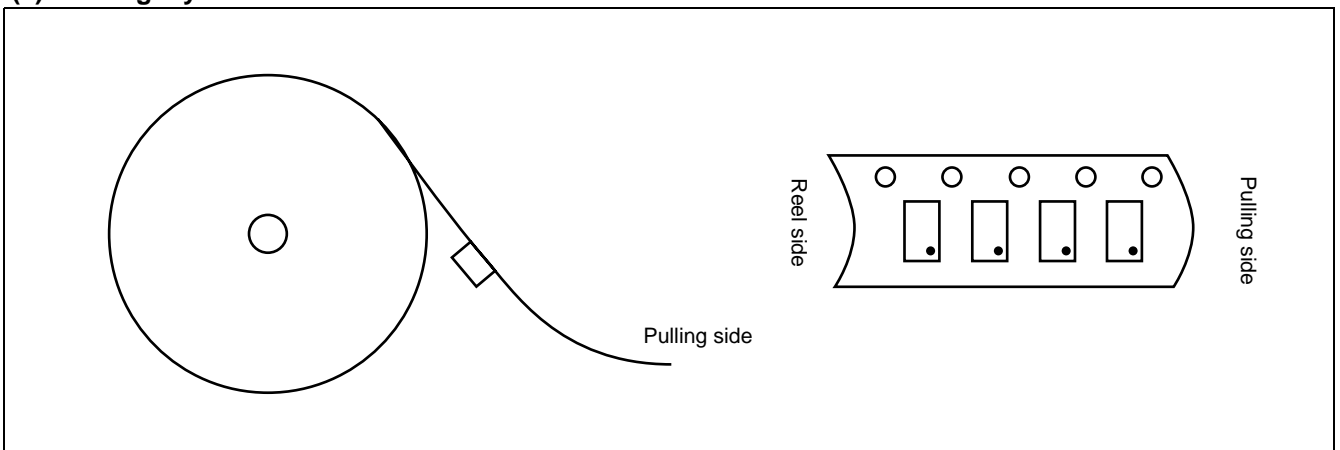

F5CP/F6CP Series

(3) Tape dimensions

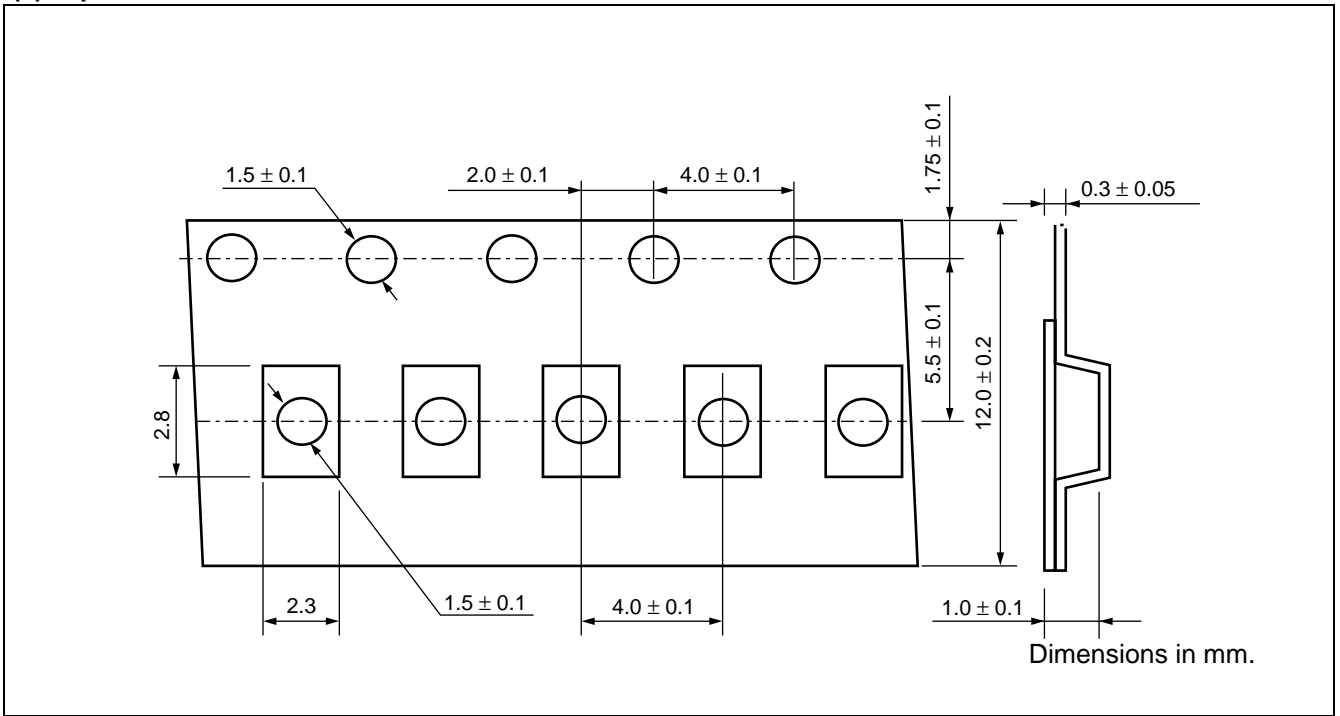

(4) Peel strength of top cover tape

Peel off by the force of 0.1 N to 0.7 N under the condition at the right .
(Conforms to JIS C 0806 section 5.2)

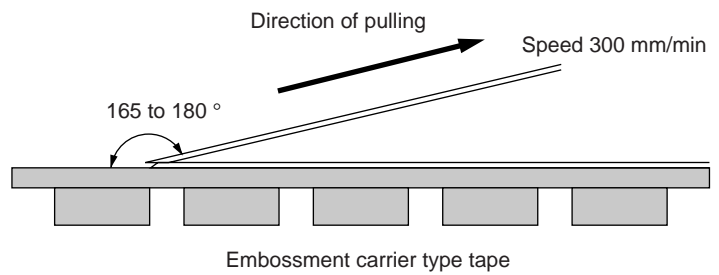

RECOMMENDED REFLOW PROFILE

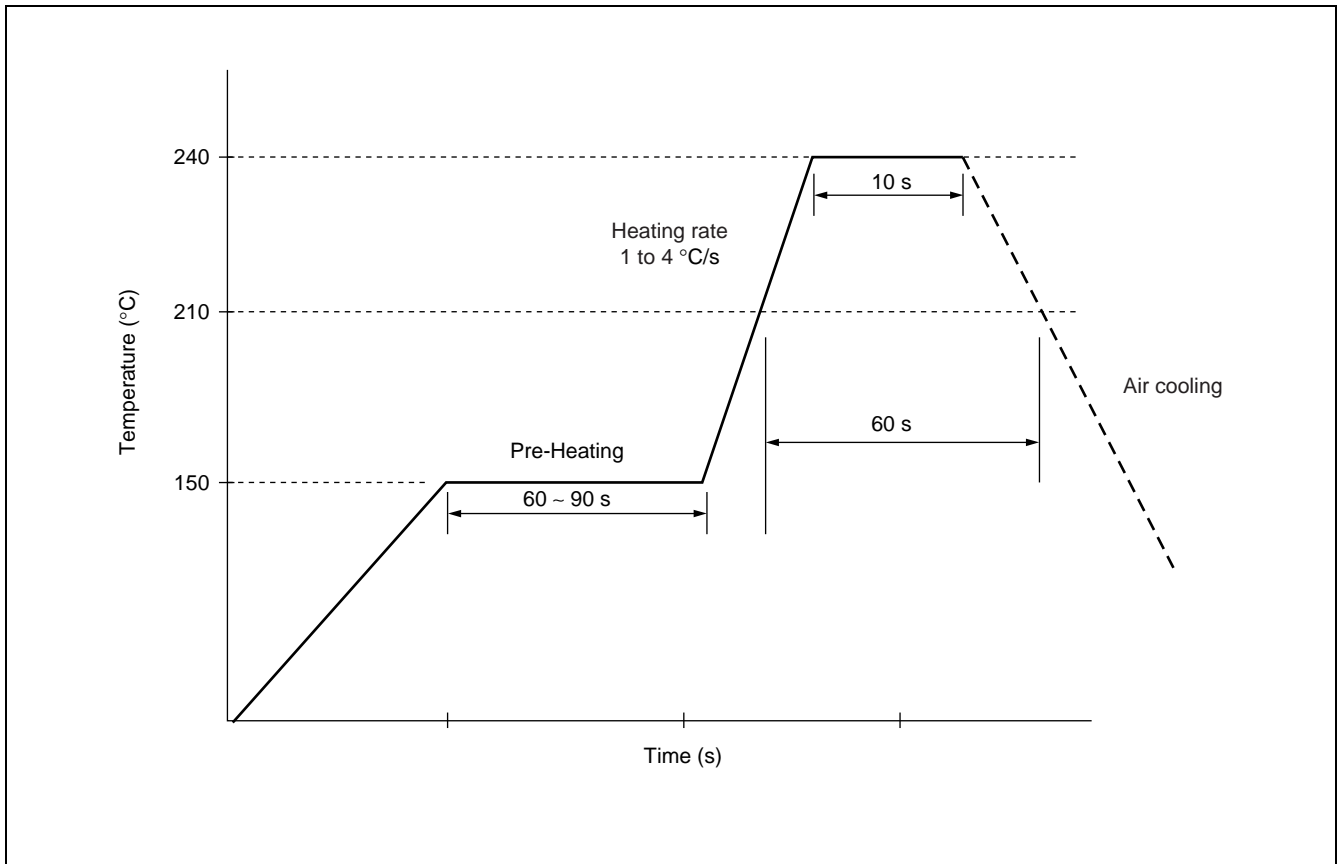

NOTE

Mass-produced product order is accepted by a unit of 1000.

F5CP/F6CP Series

FUJITSU MEDIA DEVICES LIMITED

For further information please contact:

Japan

FUJITSU MEDIA DEVICE LIMITED
International Sales & Marketing DEPT.
Shin-Yokohama Square Bldg., 14F,
Shin-yokohama 2-3-12,
Kohoku-ku, Yokohama,
Kanagawa 222-0033, Japan
Tel: +81-45-471-0061
Fax: +81-45-471-0076

<http://www.fujitsu.co.jp/hypertext/fmd/English/index.html>

North and South America

FUJITSU MICROELECTRONICS, INC.
3545 North First Street,
San Jose, CA 95134-1804, U.S.A.
Tel: +1-408-922-9000
Fax: +1-408-922-9179

Customer Response Center
Mon. - Fri.: 7 am - 5 pm (PST)
Tel: +1-800-866-8608
Fax: +1-408-922-9179

<http://www.fujitsumicro.com/>

Europe

FUJITSU MICROELECTRONICS EUROPE GmbH
Am Siebenstein 6-10,
D-63303 Dreieich-Buchsschlag,
Germany
Tel: +49-6103-690-0
Fax: +49-6103-690-122

<http://www.fujitsu-fme.com/>

Asia Pacific

FUJITSU MICROELECTRONICS ASIA PTE. LTD.
#05-08, 151 Lorong Chuan,
New Tech Park,
Singapore 556741
Tel: +65-281-0770
Fax: +65-281-0220

<http://www.fmap.com.sg/>

F0012

© FUJITSU LIMITED Printed in Japan

All Rights Reserved.

The contents of this document are subject to change without notice. Customers are advised to consult with FUJITSU sales representatives before ordering.

The information and circuit diagrams in this document are presented as examples of semiconductor device applications, and are not intended to be incorporated in devices for actual use. Also, FUJITSU is unable to assume responsibility for infringement of any patent rights or other rights of third parties arising from the use of this information or circuit diagrams.

The contents of this document may not be reproduced or copied without the permission of FUJITSU LIMITED.

FUJITSU semiconductor devices are intended for use in standard applications (computers, office automation and other office equipments, industrial, communications, and measurement equipments, personal or household devices, etc.).

CAUTION:

Customers considering the use of our products in special applications where failure or abnormal operation may directly affect human lives or cause physical injury or property damage, or where extremely high levels of reliability are demanded (such as aerospace systems, atomic energy controls, sea floor repeaters, vehicle operating controls, medical devices for life support, etc.) are requested to consult with FUJITSU sales representatives before such use. The company will not be responsible for damages arising from such use without prior approval.

Any semiconductor devices have inherently a certain rate of failure. You must protect against injury, damage or loss from such failures by incorporating safety design measures into your facility and equipment such as redundancy, fire protection, and prevention of over-current levels and other abnormal operating conditions.

If any products described in this document represent goods or technologies subject to certain restrictions on export under the Foreign Exchange and Foreign Trade Control Law of Japan, the prior authorization by Japanese government should be required for export of those products from Japan.