

Canon



Laser Beam Printer

LASER SHOT

LBP-1120

*Automatic
Image
Refinement*

CAPT
Canon Advanced Printing Technology

User's Guide

www.DataSheet4U.com



www.DataSheet4U.com

ENG

LBP-1120 Laser Printer User's Guide

www.DataSheet4U.com

Manuals for the Printer

The manuals for this printer are divided as follows. Please refer to them for detailed information.



Guides with this symbol are book manuals.



Guides with this symbol are PDF manuals included on the attached CD-ROM.

- **Installing and Setting Up the Printer**
- **Connecting the Printer to a PC**
- **Installing the Printer Driver**

- **Using the Printer**
- **Printer Settings**
- **Maintenance and Troubleshooting**

Getting Started Guide



**User's Guide
(This Document)**





How This Manual Is Organized

Chapter 1 Before You Start Using This Printer

Chapter 2 Paper Input and Output

Chapter 3 Using the Canon Advanced Printing Technology

Chapter 4 Maintenance

Chapter 5 Troubleshooting

Chapter 6 Appendix

Includes the main specifications, glossary, and index.

Contents

Preface	vii
How To Use This Manual	vii
Symbols Used in This Manual	vii
Abbreviations Used in This Manual	vii
Legal Notices	viii
FCC (Federal Communications Commission)	viii
EMC Directive (220 - 240 V model)	ix
Laser Safety (100 - 127 V/220 - 240 V models)	x
International Energy Star-Program	xi
Trademarks	xi
Copyright	xi
Disclaimers	xii
Legal Limitation on Usage of Your Product and the Use of Images	xii
Important Safety Instructions	xiii
Installation	xiii
Power Supply	xiv
Handling	xv
Maintenance and Inspections	xvi
Consumables	xvii

Chapter 1 Before You Start Using This Printer

Features and Benefits	1-2
Parts and Their Functions	1-4
Parts of the Printer	1-4
Inside the Front Cover	1-6
Turning the Printer ON/OFF	1-7
Turning the Printer ON	1-7
Turning the Printer OFF	1-8

Chapter 2 Paper Input and Output

Paper Requirements	2-2
Printable Paper	2-2
Paper You Cannot Use	2-6
Storing Paper	2-7
Handling Paper	2-7
Paper Delivery	2-8

Selecting Paper Delivery	2-8
Face-Down Delivery	2-9
Face-Up Delivery	2-9
Printing from the Multi-Purpose Tray	2-11
Loading Paper	2-11
Printing Envelopes from the Multi-Purpose Tray	2-14
Preparing Envelopes	2-14
Loading Envelopes	2-16
Printing from the Manual Feed Slot	2-19

Chapter 3 Using the Canon Advanced Printing Technology

Installing the CAPT	3-3
For Windows 98/Me	3-3
For Windows 2000	3-19
For Windows XP	3-29
Using the Printer on Your Network	3-38
Connecting the LBP-1120 as a Network Printer	3-38
Connecting to the LBP-1120 Already on Your Network	3-42
Canon LASER SHOT LBP-1120 Group	3-43
Uninstalling the CAPT	3-45
Printing a Document	3-47
Cancel the Print Job	3-48
Accessing the Properties Dialog Box	3-49
For Windows 98/Me	3-49
For Windows 2000/XP	3-49
Using the Printing Options	3-51
For Windows 98/Me	3-51
For Windows 2000/XP	3-57
Printing Multiple Pages on One Sheet	3-65
Scaling a Document	3-67
Selecting the Custom Paper Size Setting	3-69
Using the Overlay Printing	3-70
Specifying the Print Quality	3-73
Specifying the Toner Density	3-74
Using the Automatic Image Refinement	3-76
Using Profiles for Printing	3-77
Viewing the Printer Settings/Restoring the Default Settings	3-80
Checking the Status of a Print Job	3-81
Using the Status Window	3-81
Opening the Status Window	3-83
Closing the Status Window	3-83
Status Options	3-84
Network Printer Status	3-86

Chapter 4 Maintenance

Replacing the Toner Cartridge	4-2
Before Replacing the Toner Cartridge	4-3
Replacing the Toner Cartridge	4-6
Cleaning	4-10
Handling Toner Cartridges	4-11
Storing Toner Cartridges	4-13
Cleaning and Handling the Printer	4-14
Cleaning the Printer	4-14
Handling the Printer	4-16

Chapter 5 Troubleshooting

When You Have Trouble Printing	5-2
Problems and Solutions Without Messages	5-4
Print Quality Problems	5-4
Printer Problems	5-5
CAPT Problems	5-7
Clearing Paper Jams	5-9
Before Removing Paper Jams Inside the Printer	5-12
Paper Jam in the Paper Feed Area	5-13
Paper Jams Near the Imaging Area	5-15
Paper Jam in the Face-Down Delivery Area	5-17
Paper Jam in the Face-Up Delivery Area	5-18
Using the Trouble Shooter	5-19
Features of the Trouble Shooter	5-19
Starting the Trouble Shooter	5-19
Responding to Error Messages	5-21

Chapter 6 Appendix

Specifications	6-2
Glossary	6-4
Index	6-14

Preface

Thank you for purchasing the Canon LBP-1120. Please read this manual thoroughly before operating the printer in order to familiarize yourself with its capabilities, and to make the most of its many functions. After reading this manual, store it in a safe place for future reference.

How To Use This Manual

Symbols Used in This Manual

The following symbols are used in this manual to explain procedures, restrictions, handling precautions, and instructions that should be observed for safety.

**WARNING**

Indicates a warning concerning operations that may lead to death or injury to persons if not performed correctly. In order to use the printer safely, always pay attention to these warnings.

**CAUTION**

Indicates a caution concerning operations that may lead to injury to persons or damage to property if not performed correctly. In order to use the printer safely, always pay attention to these cautions.

**IMPORTANT**

Indicates operational requirements and restrictions. Be sure to read these items carefully in order to operate the printer correctly, and to avoid damage to the printer.

**NOTE**

Indicates a clarification of an operation, or contains additional explanations for a procedure. Reading these notes is highly recommended.

Abbreviations Used in This Manual

In this manual, product names and model names are abbreviated as follows:

Microsoft® Windows® operating system is referred to as Windows.

Canon LASER SHOT LBP-1120 is referred to as the LBP-1120.

Legal Notices

FCC (Federal Communications Commission)

■ 100 - 127 V model

Laser Beam Printer, Model L10577

This equipment has been tested and found to comply with the limits for a Class B digital device, pursuant to Part 15 of the FCC Rules. These limits are designed to provide reasonable protection against harmful interference when the equipment is operated in a residential environment. This equipment generates, uses and can radiate radio frequency energy, and if not installed and used in accordance with the operator's manual, may cause harmful interference to radio communications. However, there is no guarantee that interference will not occur in a particular installation. If this equipment does cause harmful interference to radio or television reception, which can be determined by turning the equipment off and on, the user is encouraged to try to correct the interference by one or more of the following measures:

- Reorient or relocate the receiving antenna.
- Increase the separation between the equipment and receiver.
- Connect the equipment into an outlet on a different circuit than the one to which the receiver is connected.
- Consult your local authorized Canon dealer or an experienced radio/TV technician for help.

Use of shielded cable is required to comply with class B limits in Subpart B of Part 15 of FCC Rules.

Do not make any changes or modifications to the equipment unless otherwise specified in the manual. If such changes or modifications should be made, you could be required to stop operation of the equipment.

Canon U.S.A. Inc.
One Canon Plaza, Lake Success, NY 11042, U.S.A.
Tel No. (516)328-5600

■ 220 - 240 V model

This equipment has been tested and found to comply with the limits for a Class A digital device, pursuant to Part 15 of the FCC Rules. These limits are designed to provide reasonable protection against harmful interference when the equipment is operated in a commercial environment. This equipment generates, uses, and can radiate radio frequency energy and if not installed and used in accordance with the instruction manual, may cause harmful interference to radio communications.

Operation of this equipment in a residential area is likely to cause harmful interference, in which case the user will be required to correct the interference at his own expense.

- Use of shielded cable is required to comply with Class A limits in Subpart B of Part 15 of FCC Rules.

Do not make any changes or modifications to the equipment unless otherwise specified in the manual. If such changes or modifications should be made, you could be required to stop operation of the equipment.

www.DataSheet4U.com

EMC Directive (220 - 240 V model)

"This equipment has been tested in a typical system to comply with the technical requirements of EMC Directive."

- Use of shielded cable is necessary to comply with the technical requirements of EMC Directive.

Laser Safety (100 - 127 V/220 - 240 V models)

Laser radiation could be hazardous to the human body. For this reason, laser radiation emitted inside this printer is hermetically sealed within the protective housing and external cover. No radiation can leak from the printer in the normal operation of the product by the user.

This printer is classified as a Class 1 laser product under EN 60825-1: 1994, and as for the U.S.A., it is classified as Class 1 under the Code of Federal Regulations, 1040.10 of Title 21.



www.DataSheet4U.com

This printer has been classified under EN60825-1: 1994 and conforms to the following classes:

CLASS 1 LASER PRODUCT
LASER KLASSE 1
APPAREIL A RAYONNEMENT LASER DE CLASSE 1
APPARECCHIO LASER DI CLASSE 1
PRODUCTO LASER DE CLASE 1
APARELHO A LASER DE CLASSE 1
(220 - 240 V model only)

WARNING

Performance of procedures other than those specified in this manual may result in hazardous radiation exposure.

International Energy Star-Program



As an ENERGY STAR® Partner, Canon USA, Inc. has determined that this product meets the ENERGY STAR® Program for energy efficiency.

The International ENERGY STAR® Office Equipment Program is an international program that promotes energy saving through the use of computers and other office equipment. The program backs the development and dissemination of products with functions that effectively reduce energy consumption. It is an open system in which business proprietors can participate voluntarily. The targeted products are office equipment such as computers, displays, printers, facsimiles, and copiers. Their standards and logos are uniform among participating nations.

Trademarks

LBP, Canon, LASER SHOT, and the Canon Logo are trademarks of Canon Inc.

Microsoft®, Windows® is registered trademark or trademark of Microsoft Corporation in the United States and/or in other countries.

Other brand and product names are trademarks or registered trademarks of their respective companies.

Copyright

Copyright 2002 by Canon Inc. All rights reserved.

No part of this publication may be reproduced or transmitted in any form or by any means, electronic or mechanical, including photocopying and recording, or by any information storage or retrieval system without the prior written permission of Canon Inc.

Disclaimers

The information in this document is subject to change without notice.

CANON INC. MAKES NO WARRANTY OF ANY KIND WITH REGARD TO THIS MATERIAL, EITHER EXPRESS OR IMPLIED, EXCEPT AS PROVIDED HEREIN, INCLUDING WITHOUT LIMITATION, THEREOF, WARRANTIES AS TO MARKETABILITY, MERCHANTABILITY, FITNESS FOR A PARTICULAR PURPOSE OF USE OR AGAINST INFRINGEMENT OF ANY PATENT. CANON INC. SHALL NOT BE LIABLE FOR ANY DIRECT, INCIDENTAL, OR CONSEQUENTIAL DAMAGES OF ANY NATURE, OR LOSSES OR EXPENSES RESULTING FROM THE USE OF THIS MATERIAL.

Legal Limitation on Usage of Your Product and the Use of Images

Using your product to scan, print or otherwise reproduce certain documents, and the use of such images as scanned, printed or otherwise reproduced by your product, may be prohibited by law and may result in criminal and/or civil liability. A non-exhaustive list of these documents is set forth below. This list is intended to be a guide only. If you are uncertain about the legality of using your product to scan, print or otherwise reproduce any particular document, and/or of the use of the images scanned, printed or otherwise reproduced, you should consult in advance with your legal advisor for guidance.

- Paper Money
- Money Orders
- Certificates of Deposit
- Postage Stamps
(canceled or uncanceled)
- Identifying Badges or Insignias
- Selective Service or Draft Papers
- Checks or Drafts Issued by
Governmental Agencies
- Motor Vehicle Licenses and
Certificates of Title
- Travelers Checks
- Food Stamps
- Passports
- Immigration Papers
- Internal Revenue Stamps (canceled
or uncanceled)
- Bonds or Other Certificates of
Indebtedness
- Stock Certificates
- Copyrighted Works/Works of Art
without Permission of Copyright
Owner

Important Safety Instructions

Please read these "Important Safety Instructions" thoroughly before operating the printer. As these instructions are intended to prevent injury to the user or other persons or destruction of property, always pay attention to these instructions. Also, since it may result in unexpected accidents or injuries, do not perform any operation unless otherwise specified in the manual. Improper operation or use of this printer could result in personal injury and/or damage requiring extensive repair that may not be covered under your Limited Warranty.

Installation

WARNING

- Do not install the printer near alcohol, paint thinner, or other flammable substances. If flammable substances come into contact with electrical parts inside the printer, it may result in a fire or electrical shock.
- Do not place the following items on the printer. If these items come into contact with a high-voltage area inside the printer, it may result in a fire or electrical shock.
- If these items are dropped or spilled inside the printer, immediately turn OFF the power switch, and unplug the power plug from the outlet. Then, contact your local authorized Canon dealer.
 - Necklaces and other metal objects
 - Cups, vases, flowerpots, and other containers filled with water or liquids

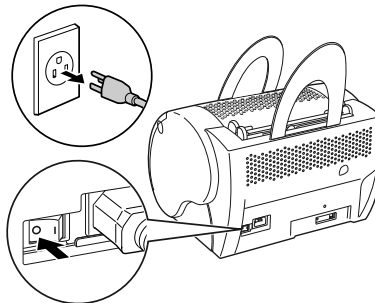

CAUTION

- Do not install the printer in unstable locations, such as unsteady platforms or inclined floors, or in locations subject to excessive vibrations, as this may cause the printer to fall or tip over, resulting in personal injury.

- Never block the ventilation slots and louvers on the printer. These openings are provided for proper ventilation of working parts inside the printer. Blocking these openings can cause the printer to overheat. Never place the printer on a soft surface, such as a sofa or rug.
- Do not install the printer in the following locations:
 - A damp or dusty location.
 - A location exposed to smoke and steam, such as near stoves and humidifiers.
 - A location exposed to rain and snow.
 - A location near water faucets and water.
 - A location which is exposed to direct sunlight.
 - A location subject to high temperatures.
 - A location that is subject to open flames.
- To avoid damaging the printer or personal injury, carry the printer in the manner shown in the illustration below. Hold it firmly, with one hand on each side.
- When connecting the interface cable, connect it properly according to the instruction in this manual. If not connected properly, it may result in a malfunction or electrical shock.
- When moving the printer, follow the instructions in this manual to hold it correctly. Failure to do so may cause you to drop the printer, resulting in personal injury.

www.DataSheet4U.com

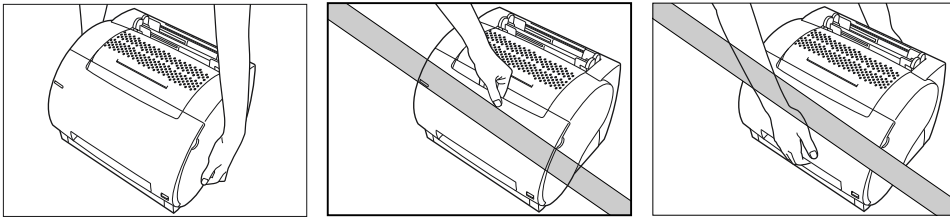

Power Supply

! WARNING

- Do not damage or modify the power cord. Also, do not place heavy objects on the power cord, or pull on or excessively bend it, as this could cause electrical damage and result in a fire or electrical shock.
- Keep the power cord away from a heat source; failure to do so may cause the cord coating to melt, resulting in a fire or electrical shock.
- Do not insert or unplug the power plug with wet hands, as this may result in electrical shock.
- Do not plug the printer into a multi-plug power strip, as this may cause a fire or electrical shock.
- Do not bundle up or tie the power cord in a knot, as this may result in a fire or electrical shock.
- Insert the power cord completely into the outlet, as failure to do so may result in a fire or electrical shock.

- As a general rule, do not use extension cords. Using an extension cord may result in a fire or electrical shock. If an extension cord must be used, however, use one rated for voltages of AC 230 V and over and untie the cord binding and insert the power plug completely into the extension cord outlet to ensure a firm connection between the power and extension cord.

CAUTION

- Do not use power supplies with voltages other than those specified herein, as this may result in a fire or electrical shock.
- Always grasp the plug when unplugging the power plug. Pulling on the power cord may expose or snap the core wire, or otherwise damage the power cord. If the cord is damaged, this could cause a current to leak, resulting in a fire or electrical shock.
- Leave sufficient space around the power plug so that it can be unplugged easily. If objects are placed around the power plug, you will be unable to unplug it in an emergency.

Handling

WARNING

- Do not attempt to disassemble or modify the printer. There are high-temperature and high-voltage components inside the printer which may cause a fire or electrical shock.
- Electrical equipment can be hazardous if not used properly. To avoid injury, do not allow children access to the interior of any electrical product, and do not let them touch any electrical contacts or gears that are exposed.
- If the printer makes strange noises, or gives off smoke, heat or unusual smells, immediately turn OFF the power switch, and unplug the power plug from the outlet. Then, contact your local authorized Canon dealer. Continued use of the printer in this condition may result in a fire or electrical shock.
- Do not use highly flammable sprays near the printer. If gas from these sprays comes into contact with the electrical components inside the printer, it may result in a fire or electrical shock.
- To avoid damage to the power cord and creating a fire hazard, always turn the main power switch to OFF, and unplug the interface cable when moving the printer. Otherwise the power cord and interface cable may be damaged, resulting in a fire or electrical shock.
- Do not drop paper clips, staples or other metal objects inside the printer. Also, do not spill water, liquids or flammable substances (alcohol, benzene, paint thinner, etc.) inside the printer. If these items come into contact with a high-voltage area inside the printer, it may result in a fire or electrical shock. If these items are dropped or spilled inside the printer, immediately turn the main power switch to OFF and unplug the power plug from the outlet. Then contact your local authorized Canon dealer.
- When unplugging the USB cable while the power switch is turned ON, do not touch the metal part of the connector. This may lead to electrical shock.

⚠ CAUTION

- Do not place heavy objects on the printer, as they may tip over or fall resulting in personal injury.
- Turn OFF the main power switch for safety when the printer will not be used for a long period of time, such as overnight. Also, turn OFF the main power switch on the back of the printer and unplug the power plug for safety when the printer will not be used for an extended period of time, such as during consecutive holidays.
- The laser beam can be harmful to human bodies. Since radiation emitted inside the product is completely confined within protective housings and external covers, the laser beam can not escape from the printer during any phase of user operation. Read the following remarks and following instructions for safety.
- Never open covers other than those instructed in this manual.
- Do not remove the caution label attached to the laser scanner unit inside the printer.

www.DataSheet4U.com

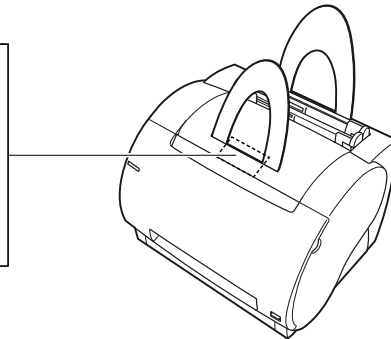

- If the laser beam escapes from the printer, exposure may cause serious damage to your eyes.

Maintenance and Inspections

⚠ WARNING

- When cleaning the printer, first turn OFF the main power switch, then unplug the power plug. Failure to observe these steps may result in a fire or electrical shock.
- Unplug the power plug from the outlet regularly, and clean the area around the base of the plug's metal pins and the power outlet with a dry cloth to ensure all dust and grime is removed. If the printer is plugged in for a long period of time in a damp, dusty, or smoky location, dust can build up around the plug and become damp. This may cause a short circuit and result in a fire.
- There are some areas inside the printer which are subject to high voltages. When removing jammed paper or when inspecting the inside of the printer, do not allow necklaces, bracelets, or other metal objects to touch the inside of the printer, as this may result in burns or electrical shock.

- Do not throw used toner cartridges into open flames. The remaining toner inside the cartridges will ignite and may cause burns or a fire.

CAUTION

- Never attempt to service this printer yourself, except as explained in this manual. There are no user serviceable parts inside the printer. Adjust only those controls that are covered in the operating instructions. Improper adjustment could result in personal injury and/or damage requiring extensive repair that may not be covered under your Limited Warranty.
- The fixing unit and its surroundings inside the printer may become hot during use. When removing jammed paper or when inspecting the inside of the printer, do not touch the fixing unit and its surroundings, as this may result in burns or electrical shock.

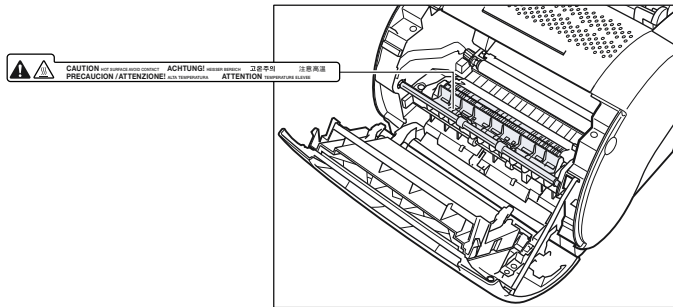

- When removing jammed paper or replacing the toner cartridge, take care not to allow the toner to come into contact with your hands or clothing, as this will dirty your hands or clothing. If they become dirty, wash them immediately with cold water. Washing with warm water will set the toner, and make it impossible to remove the toner stains.
- When removing paper which has become jammed inside the printer, remove the jammed paper gently to prevent the toner on the paper from scattering and entering your eyes or mouth. If toner enters your eyes or mouth, wash them immediately with cold water and immediately consult a physician.
- When loading paper or removing jammed paper, take care not to cut your hands on the edges of the paper.
- When removing used toner cartridges from the toner cartridge slot, remove the cartridge carefully to prevent the toner from scattering and entering your eyes or mouth. If the toner enters your eyes or mouth, wash them immediately with cold water and immediately consult a physician.

Consumables

WARNING

- Do not throw used toner cartridges into open flames. The remaining toner inside the cartridges will ignite and may cause burns or a fire.

- Do not store toner cartridges or copy paper in places exposed to open flames, as this may cause the toner or paper to ignite, resulting in burns or a fire.



CAUTION

Keep toner and other consumables out of the reach of small children. If these items are ingested, consult a physician immediately.

Before You Start Using This Printer

1

CHAPTER

This chapter describes the major features, the functions of the printer and how to turn the printer ON and OFF.

Features and Benefits	1-2
Parts and Their Functions	1-4
Parts of the Printer	1-4
Inside the Front Cover	1-6
Turning the Printer ON/OFF	1-7
Turning the Printer ON	1-7
Turning the Printer OFF	1-8

www.DataSheet4U.com

Features and Benefits

1

Before You Start Using This Printer

The LBP-1120 combines the following features to form a versatile printing system:

Quick startup

The printer is ready to print soon after it is turned on (no start-up time), and has a first print time of less than 17 seconds. This means that you can print documents quickly and efficiently.

Impressive output

Thanks to CAPT (Canon Advanced Printing Technology), the 600 dpi resolution gives you crisp, clean, laser-sharp output at 10 pages per minute.

Lower power consumption

The printer comes with an efficient power management system. Power consumption is very low, particularly when idle.

Stylish, compact design

The printer provides compact, lightweight, easy-to-use functionality in a smooth, stylish design. The small footprint gives you more work space to help you meet your needs.

CAPT Printing Software

The CAPT is easy to install, and with it you can set custom paper sizes, overlay bitmaps on documents (for example, you can print your logo on each page), tile up to nine pages on one sheet of paper, and switch easily between complicated setups using user-defined profiles. The Status Window gives you written and spoken feedback about your print jobs, even over a network.

Quiet operation

Its quiet operation makes this printer an ideal output device, even in an open-office environment.

Flexible paper handling

Both the multi-purpose tray and the manual feed slot accept plain paper of various sizes—Letter, Legal, A4, B5, or Executive—as well as transparencies, labels, envelopes, postcards and other special paper. The multi-purpose tray handles up to 125 sheets of 64 g/m² plain paper with a maximum stack height of 12.5 mm. For manual feeding, sheets are fed one at a time. Delivery can be face down (for plain paper) or face up (for all paper types).

Network Connection

You can connect to the LBP-1120 over a network, going through a server.

Parts and Their Functions

1

Before You Start Using This Printer

The following section describes the parts of the printer, and their various functions, so that you can make full use of all the features of your printer.

Parts of the Printer

Front View

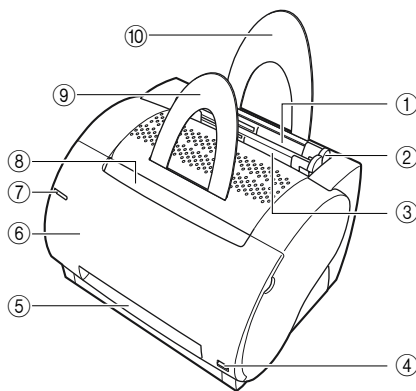

① Multi-Purpose Tray

Holds a variety of print media such as plain paper, envelopes, labels, transparencies and non-standard size paper. The capacity of the tray is approximately 125 sheets of plain paper (64 g/m²). (See "Printing from the Multi-Purpose Tray," on p. 2-11.)

② Paper Guides

Adjust to the size of the paper loaded in the multi-purpose tray. The guides can easily be adjusted by hand.

③ Manual Feed Slot

Use when you load print media manually, one sheet at a time. (See "Printing from the Manual Feed Slot," on p. 2-19.)

④ Paper Delivery Selector

Use to choose face-up or face-down delivery. (See "Selecting Paper Delivery," on p. 2-8.)

⑤ Face-Up Delivery Slot

Printouts come out from the slot face up. (See "Face-Up Delivery," on p. 2-9.)

⑥ Front Cover

Open to install the toner cartridge, clear paper jams, and for printer maintenance.

⑦ Power Lamp

Lights blue when the printer is turned on.

⑧ Face-Down Delivery Slot

Printouts come out from the slot face down. (See "Face-Down Delivery," on p. 2-9.)

⑨ Face-Down Output Paper Support

Supports the printouts from the face-down delivery slots to prevent them from drooping and being bent.

⑩ Input Paper Support

Supports the stack of paper loaded into the multi-purpose tray so that paper can be fed into the slot correctly.

Rear View

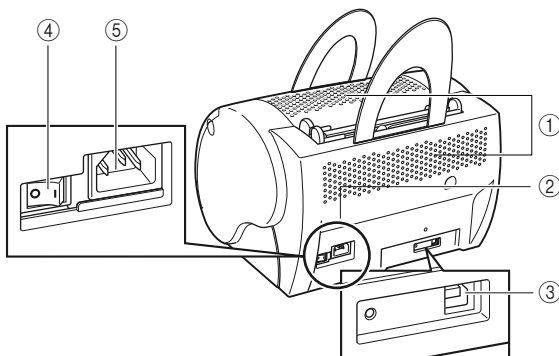

① Ventilation Slots

Slots ventilating the air blown by the fan cooling the printer's interior. Avoid blocking these slots when you install the printer.

② Rating Label

The serial number is indicated to identify the printer. Refer to this number when calling a service technician. This label also shows the current and average power consumption.

③ USB Port Interface Connector

Connects to a USB interface cable. Use this port when connecting the printer to a computer with the printer cable.

④ Power Switch

Press to turn the printer ON/OFF. (See "Turning the Printer ON/OFF," on p. 1-7.)

⑤ Power Socket

Connects to an AC outlet.

Inside the Front Cover

1

Before You Start Using This Printer

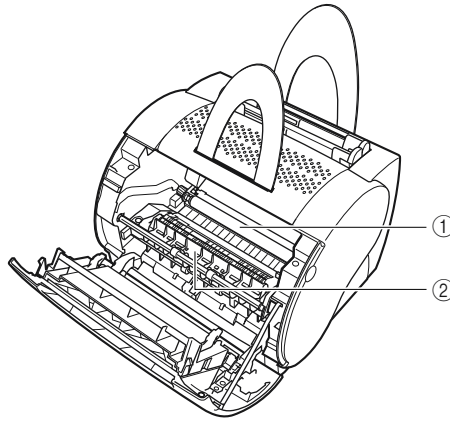

① Transfer Roller

This delicate roller should be kept free of fingerprints and oil to prevent print quality deterioration.

② Fixing Unit

Fixes the toner onto print media.

Turning the Printer ON/OFF

This section describes how to turn the printer ON and OFF.

Turning the Printer ON

Follow the procedure to turn the printer ON.

- 1 Turn the power switch to ON ("I" side). The power switch is located on the back side of the printer.**

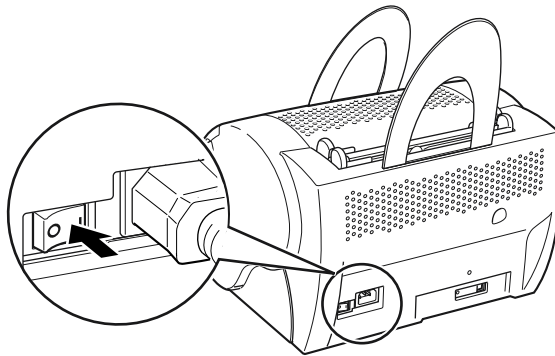

NOTE

- If the power does not turn on even when the printer is plugged into an AC outlet, check the following items:
- Close the front cover if open.
 - Make sure that the EP-22 cartridge is installed.
 - If the EP-22 cartridge is already installed, remove and reinstall it.
 - To reset the printer, turn off the power using the power switch, and unplug the power cord. Wait two seconds or more, then connect the printer to the AC outlet again.

Turning the Printer OFF

Follow the procedure to turn the printer OFF.

 **IMPORTANT**

- If the printer is connected to a network, make sure that the printer is not printing data from another personal computer before turning OFF the power.
- Do not turn OFF the power to the printer while it is printing.
- Turn the printer ON about 10 seconds after it was turned OFF.

- 1 Turn the power switch to OFF ("O" side). The power switch is located on the back side of the printer.**

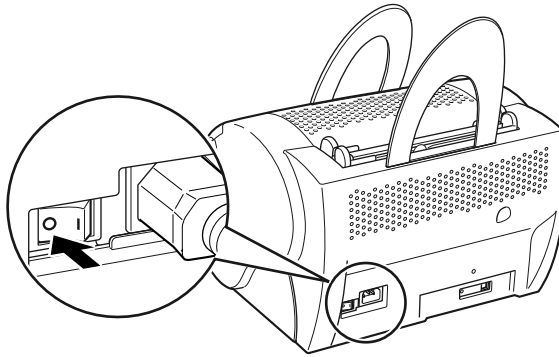

Paper Input and Output

2

CHAPTER

This chapter explains the types of paper available for this printer, and how to load and print out paper.

Paper Requirements	2-2
Printable Paper	2-2
Paper You Cannot Use	2-6
Storing Paper	2-7
Handling Paper	2-7
Paper Delivery	2-8
Selecting Paper Delivery	2-8
Face-Down Delivery	2-9
Face-Up Delivery	2-9
Printing from the Multi-Purpose Tray	2-11
Loading Paper	2-11
Printing Envelopes from the Multi-Purpose Tray	2-14
Preparing Envelopes	2-14
Loading Envelopes	2-16
Printing from the Manual Feed Slot	2-19

www.DataSheet4U.com

Paper Requirements

This section describes the size and type of paper you can use with this printer.

Printable Paper

You can use the following types of paper with this printer. To ensure optimum performance, only use paper that falls within the specifications listed below.

General Specifications

Type of Paper	Paper Size	Weight	Paper Source Capacity	
			Multi-Purpose Tray	Manual Feed Slot
Plain paper	76.2 × 127 - 216 × 356 mm A4: 210 × 297 mm B5: 182 × 257 mm	64 g/m ²	Max. height: 12.5 mm (About 125 sheets of 64 g/m ² paper)	1 sheet
Heavy paper	Legal: 216 × 356 mm Letter: 216 × 279 mm Executive: 184 × 267 mm	91 - 135 g/m ²	Max. height: 12.5 mm	1 sheet
Transparencies	Letter, A4	—	Max. height: 12.5 mm	1 sheet
Label sheets	Letter, A4	—	Max. height: 12.5 mm	1 sheet
Postcards	100 × 148 mm	—	Max. height: 12.5 mm	1 sheet
Envelopes	98 × 162 mm - 176 × 250 mm (COM 10, Monarch, DL, C5)	—	Max. height: 12.5 mm	1 sheet
Others	Index card: 76.2 × 127 mm*	—	Max. height: 12.5 mm	1 sheet

* Only use index cards that are 0.18 mm to 0.28 mm thick.

IMPORTANT

Printing speed may vary depending on: paper size, paper type, or number of pages to be printed. This is due to protective functions working in order to prevent troubles such as breakdown caused by heating.

Paper Capacity of Paper Sources

Type of Paper	Paper Source	
	Multi-Purpose Tray	Manual Feed Slot
Plain Paper 64 g/m ²	About 125 sheets	1 sheet
Heavy Paper 91 - 135 g/m ²	About 85 sheets	1 sheet
Transparencies	About 100 sheets	1 sheet
Label sheets	About 80 sheets	1 sheet
Postcards	About 45 sheets	1 sheet
Envelopes	About 7 sheets	1 sheet

Paper Capacity of the Paper Delivery Tray

Type of Paper	Paper Delivery Tray
	Face-Down Delivery Tray
Plain Paper 64 g/m ²	About 50 sheets



IMPORTANT

The printer is not equipped with a face-up delivery tray. Remove each sheet from the face-up delivery slot manually after it has been printed.

Abbreviations of Paper Sizes

The size indicators for the paper guides on the multi-purpose tray uses the following abbreviations:

Paper Size	Paper Size Indicators for the Paper Guides
A4	A4
Legal	LGL
Letter	LTR

Plain Paper

Follow these guidelines when selecting paper:



IMPORTANT

- Paper that is too thick or too thin, or that has irregular shapes, cutouts, or perforations should not be used.
- Never use paper that is wet, highly textured, rough, torn, wrinkled, or damaged.
- Extremely smooth paper or paper with special coatings does not print well.
- The laser printing process uses high temperatures to fuse toner to the paper. Use paper that will not melt, vaporize, offset, discolor, or emit dangerous fumes at about 190°C (374°F).
- Do not use thermal or carbon paper, or paper with glue, staples, clips, or ribbons.

For colored paper, use colors that are not damaged by the heat of the printer's fixing unit (about 190°C or 374°F).

Transparencies

The acceptable sizes are Letter or A4. The transparencies must be able to withstand the heat generated by the fixing unit (about 190°C or 374°F) without damage.

Heavy (Thick) Paper

This printer can handle thick paper of 91 - 135 g/m². Thick paper can be loaded into both the multi-purpose tray and the manual feed slot.



IMPORTANT

The size of thick paper (91 - 135 g/m²) that can be loaded in the tray is 76.2 - 216 mm wide and 127 - 356 mm long. You can load up to about 85 sheets of the paper (105 g/m²) into the multi-purpose tray.

Label Sheets

Label sheets are paper with pressure-sensitive adhesive. Acceptable sizes are Letter and A4. Follow these guidelines when choosing a label sheet:



IMPORTANT

- The label print face (top, or face sheet) must be made of ordinary, matte-finish paper similar to copy paper.
- The paper backing must be able to withstand the heat generated by the fixing unit (about 190°C or 374°F). The backing must not be made of easily removable coated paper.
- Do not use labels with exposed adhesive, which may stick to the cartridge or the fixing roller, causing the labels to peel off and serious paper jams to occur.

Envelopes

Follow these guidelines when printing on envelopes:



IMPORTANT

- Envelopes must not have any fasteners, snaps, or windows, or be made of artificial materials.
- Do not use envelopes that discolor or melt at about 190°C (374°F), envelopes which might emit dangerous fumes when heated, or envelopes that seal with pressure-sensitive adhesives.
- Do not use envelopes which are damaged, curled or wrinkled, or that have an irregular shape.
- Do not use oversized envelopes, or envelopes with folds.
- Poorly manufactured envelopes are not recommended.

Postcards

Follow these guidelines when printing on postcards:



IMPORTANT

- Postcards should not be greater than 0.28 mm in thickness.
- Postcards should be free of glue, clips, and staples.
- Do not use postcards that are damaged or curled, or that have special coatings or an irregular shape.

Paper You Cannot Use

To avoid problems such as paper jams and printer malfunctions, the following types of paper should never be used.



IMPORTANT

- The following paper tends to cause paper jams. Paper that is:
 - too thick or too thin.
 - irregular shaped.
 - wet or holding moisture.
 - torn or damaged.
 - rough, extremely smooth, or glossy.
 - wrinkled.
 - folded at corners.
 - curled or creased.
 - Paper that has holes for binding or perforations.
 - Paper that has special coating on its surface (coated paper for ink jet printers, etc.).
 - Adhesive labels with the base easily peeled.
 - Paper that has been used once by the printer, copy machine or other laser printers. (The back side of this paper is also unusable. However, note that you can use the manual feed slot to perform manual duplex printing on the reverse side of a sheet of paper that has already been printed on using this printer. You cannot print on the same side of a sheet of paper that has already been printed on.)
- Paper that changes its quality at high temperature.
- Paper that uses ink that melts, burns, evaporates or emits harmful gases with the temperature (about 190°C or 374°F) of the fixing unit.
 - Heat-sensitive paper.
 - Paper used for color printing with a processed surface.
 - Paper with adhesive on its surface.
- Paper that causes failure or damage to the printer.
 - Carbon paper.
 - Paper with staples, clips, ribbons or tapes.
- Paper that is difficult for the toner to adhere to.
 - Paper with rough surfaces.
 - Paper containing thick fibers.

Storing Paper

Handling and storing paper properly ensures high print quality, and prevents potential paper jams. Using paper that is crumpled or exposed to moisture or direct sunlight during improper storage or handling can contribute to poor print quality and paper jams. Follow these guidelines when you store and handle paper:



IMPORTANT

- Choose an appropriate location for storage.
For best performance, keep the ambient storage and work area temperature to 20°C (±3%) or 68°F (±5%). Keep the relative humidity at 45% (±5%).
- Guard against moisture.
Paper quality degrades in a moist environment. Store all unused paper in its wrapper. Never store paper on the floor where water and moisture can collect. In areas of high humidity, you may need to store paper in a specially designed storage box.
- Avoid direct sunlight.
Exposure to direct sunlight can dramatically degrade paper quality. Store paper away from sunlight, and keep unused paper in its wrapper.
- Avoid sudden changes in temperature or humidity.
If paper is moved between locations that differ widely in temperature or humidity, it may curl. If this situation cannot be avoided, store the paper in the work area by the printer for at least one day to give the paper time to adjust to the new conditions.
- Avoid physical damage to stored paper.
Store paper on a flat surface to avoid creasing or curling. Never store paper on its end or lean it against something.

www.DataSheet4U.com

Handling Paper



IMPORTANT

- Check the paper and make sure that it is not torn, folded or otherwise damaged.
- Leave unused paper in its wrapper.
- Never mix different types of paper when you load the multi-purpose tray.
- Always wait until the tray is empty before loading fresh paper. This helps to avoid paper jams.
- If paper in the delivery slot is excessively curled, turn over the paper stack in the tray.

Paper Delivery

This printer delivers the printed pages in two delivery methods, face-up delivery and face-down delivery.

This section describes how to select the paper delivery methods.

2

Paper Input and Output

■ Paper Type and Paper Delivery

Refer to the list below to select the proper paper delivery method depending on the type of paper.

Type of Paper	Paper Delivery	Paper Stack Capacity
Plain Paper	Face-up	1 sheet (64 g/m ²)
	Face-down	About 50 sheets (64 g/m ²)
Transparencies	Face-up	1 sheet
Labels	Face-up	1 sheet
Postcards	Face-up	1 sheet
Envelopes	Face-up	1 sheet
Index cards	Face-up	1 sheet

Selecting Paper Delivery

Use the paper delivery selector to select face-up or face-down delivery.

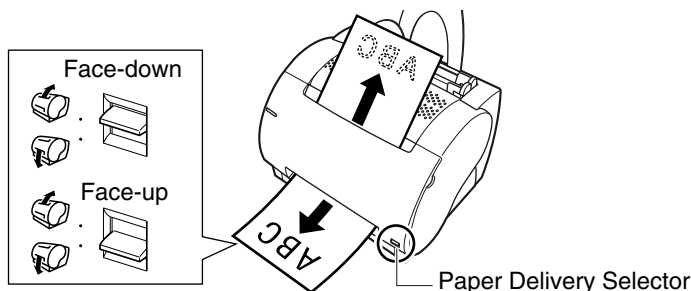

IMPORTANT

Do not switch the paper delivery selector until the printout has completely come out of the delivery slots. Switching the paper delivery selector while printing may cause a paper jam.

Face-Down Delivery

Use face-down delivery for plain paper only. Printouts are stacked in order in the face-down delivery slot (which can hold up to 50 sheets of plain paper 64 g/m²).

- 1** Move the paper delivery selector up to the face-down mark.

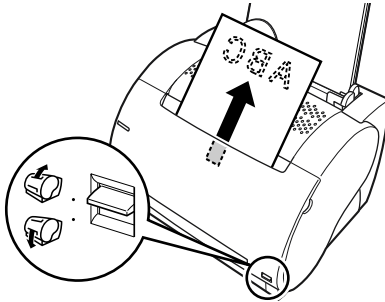

IMPORTANT

- Do not replace paper in the face-down delivery slot once it is removed from the slot. This could result in damage to the flaps inside the slot.
- Never insert paper or other objects into the face-down delivery slot.

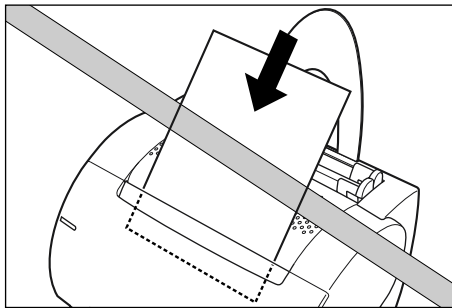

Face-Up Delivery

Use face-up delivery for envelopes and transparencies, as well as other special paper including non-standard sized plain paper. Printouts come out from the face-up delivery slot face up. This helps prevent paper curl.

1 Push the paper delivery selector down to the face-up mark.

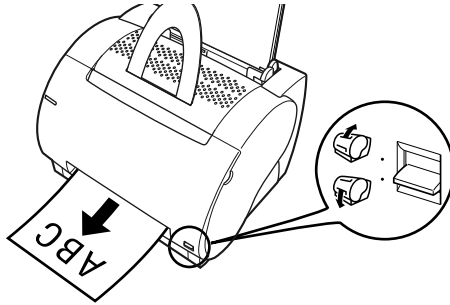

Remove each sheet manually from the face-up delivery slot after it has been printed.



IMPORTANT

- Do not pull out the printout while it is still emerging from the face-up delivery slot.
- Make sure that there is enough room at the front of the printer for paper to exit.



NOTE

The printer is not equipped with a face-up delivery tray. The delivered paper must be removed manually.

Printing from the Multi-Purpose Tray

The multi-purpose tray can hold up to approximately 125 sheets of 64 g/m² paper for high volume printing. Acceptable paper sizes are Letter, Legal, A4, Executive, and B5. It also accepts transparencies, envelopes, postcards, or special paper with a maximum height of 12.5 mm.

Before loading paper into the multi-purpose tray, first select the paper delivery. (See "Paper Delivery," on p. 2-8.)

NOTE

The maximum number of sheets of paper that can be loaded into the multi-purpose tray may vary depending on the type of paper. (See "Printable Paper," on p. 2-2.)

IMPORTANT

Make sure that the input paper support is inserted into its slot in the printer.

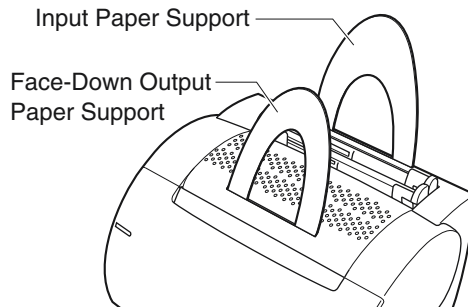

Loading Paper

Loading Paper (Other Than Envelopes)

To load plain paper, thick paper, labels, or transparencies in the multi-purpose tray, follow the procedure described below.

IMPORTANT

Data cannot be printed inside a 5 mm wide border around the paper.

1 Fan a stack of paper, then tap the stack of paper on a flat surface to properly align the edges.

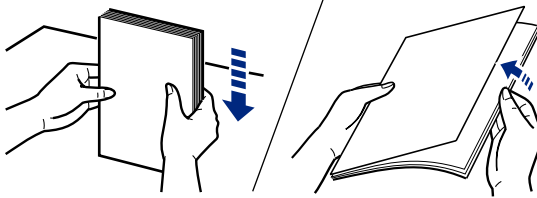

IMPORTANT

- When fanning or aligning transparencies, always hold the edges, to avoid touching the print side.
- Be sure to load a stack of transparencies after thoroughly fanning them. Not fanning them properly may cause the transparencies to overlap, causing paper jams.
- Take care not to mark/stain the print side of the transparencies with fingerprints, dust, or oil. This may cause poor print quality.
- If the leading edge of the paper is bent or curled, straighten out the paper before loading it into the tray.

2 Load the stack of paper into the multi-purpose tray as illustration below.

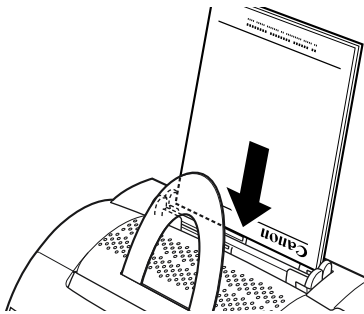

IMPORTANT

- Do not force the paper into the printer.
- Do not load more than 125 sheets of 64 g/m², or a stack of any paper higher than 12.5 mm.

3 Adjust the paper guides to the width of the paper stack.

For A4-size or Letter/Legal-size paper, align the paper guides with the icons inside the multi-purpose tray.

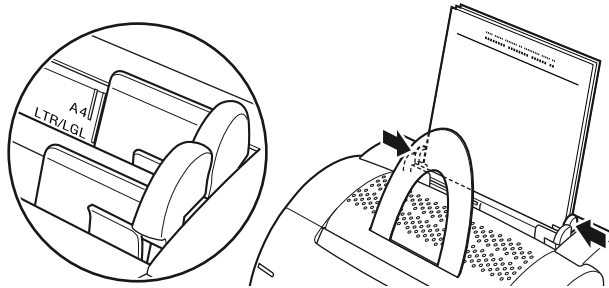

IMPORTANT

- Be sure to match the paper guides to the paper width. Misfeeds or paper jams may occur if the paper guides are too loose or too tight.
- When reloading, be sure to remove any paper remaining in the multi-purpose tray. Stack it together with the new sheets before loading.

Loading paper in the multi-purpose tray is complete.

Printing Envelopes from the Multi-Purpose Tray

Preparing Envelopes

2

Before you load envelopes in the multi-purpose tray, the following precautions should be observed.

- 1** Fan the stack of envelopes to make sure none of the envelopes stick together.

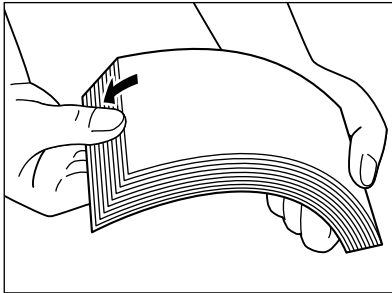

- 2** Place the envelopes on a clean, flat surface → press down on all of the corners to flatten the envelopes.

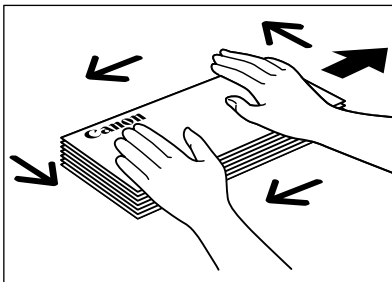

- 3** Flex the stack on all four sides to remove any stiffness. Check all corners. If the corners are curled, straighten them.

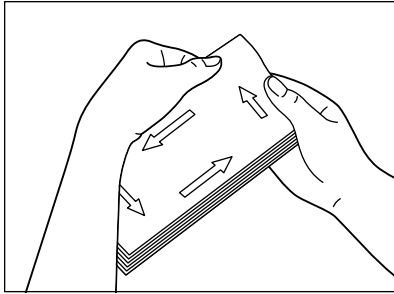

IMPORTANT

Be sure to flatten out the leading edges of the envelopes if they are curled down. This may cause a paper jam to occur.

www.DataSheet4U.com

- 4** Correct any curled corners → align the edges of the stack of envelopes by tapping them on a flat surface.

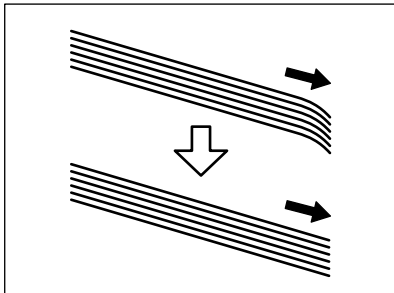

Loading Envelopes

The multi-purpose tray can hold Monarch, COM 10, C5, and DL envelopes. To load envelopes into the multi-purpose tray, follow the procedure below.

- 1** Align the stack of envelopes so that the side to be printed on faces the front of the printer. Slide the stack in until it stops.

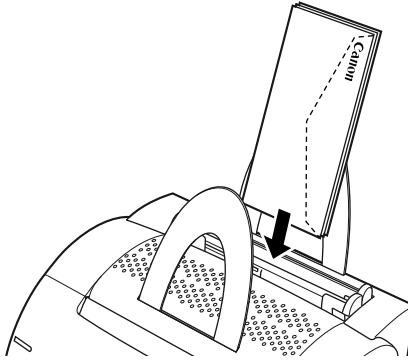

- 2** Adjust the paper guides to the width of the stack of envelopes.

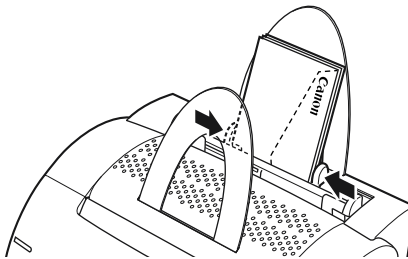

NOTE

Most applications allow you to choose which way envelopes feed into the printer. Make sure your printer settings before you print.

When using C5-size envelopes, remove any stiffness by lightly flexing both edges of the envelope.

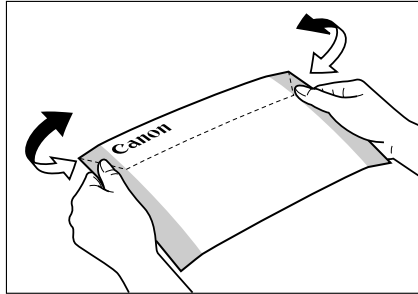

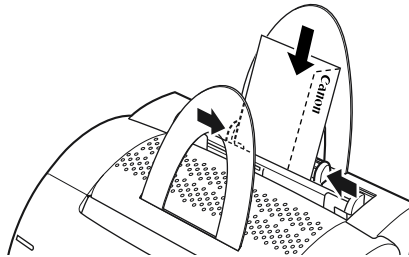

Insert the envelopes one at a time into the multi-purpose tray, in the direction shown in the illustration.

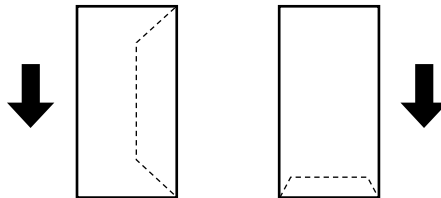

If the flap is along the long edge of the envelope, insert each envelope with the flap at the back and on the right.

If the flap is along the short edge of the envelope, insert envelopes with the flap at the bottom and at the back.



 **NOTE**

After you have loaded the envelopes into the multi-purpose tray, please check the following items to avoid paper jams or misfeeds before printing.

- Is the stack of envelopes bending? The stack may bend if the paper guides are too tight.
- Are the envelopes evenly stacked? If the paper guides are loose, the envelopes may not stack evenly or feed properly.
- Is the stack straight? Do not place the stack of envelopes at an angle.
- Are the flaps of each of the envelopes separate? If the flaps of the envelopes overlap, paper jams or misfeeds will occur.

The illustrations below show the acceptable and unacceptable arrangement of the flaps for the envelopes in the stack.

Acceptable

The flap of each envelope should be separate, not overlapping the edges of any of the other envelopes in the stack.

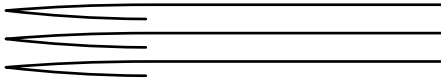

Unacceptable

If the flap of any of the envelopes overlap the edges of any of the other envelopes in the stack, like those in the example below, paper jams or misfeeds will occur.

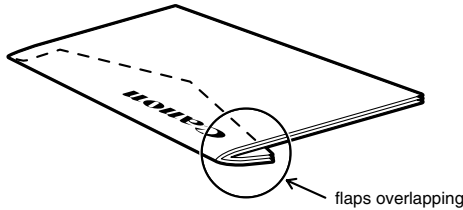

Examples of unacceptable overlapping flaps

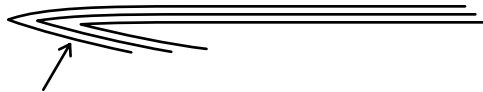

top flap and other flaps overlapping the envelopes underneath

or

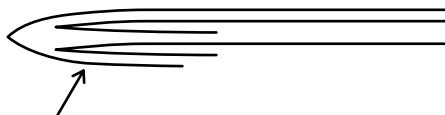

top flap overlaps the envelopes underneath

Printing from the Manual Feed Slot

The manual feed slot allows you to load paper manually, one sheet at a time. You can load transparencies, labels, envelopes, postcards, or other special paper. You can also load plain paper, which is useful when you want to use paper that is a different size from the paper in the multi purpose tray. Before loading paper manually, always select the paper delivery first. (See "Paper Delivery," on p. 2-8.)

www.DataSheet4U.com

- 1** Align the sheet of paper so that the side to be printed on faces the front of the printer and the top of the paper is inserted first. Slide the sheet of paper into the manual feeding slot until it stops.



- 2** Adjust the paper guides to the sheet of paper.

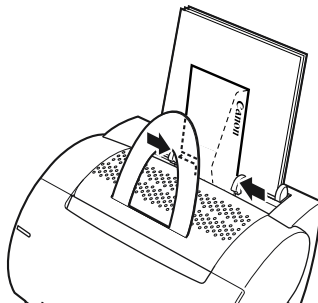



IMPORTANT

Be sure to match the paper guides to the paper width. Misfeeds or paper jams may occur if the paper guides are too loose or too tight.



NOTE

- The manual feed has priority over the multi-purpose tray.
- Often applications will let you change the feeding direction of envelopes. Confirm the feeding direction of envelopes before printing.
- If a postcard is not fed smoothly into the printer, gently push the top of the postcard downwards until the roller inside the printer takes the card and feeds it into the printer.
- When printing on postcards, the printing quality for non-characters (e. g. grayscale illustrations) may deteriorate.

Loading paper in the manual feed slot is complete.

Using the Canon Advanced Printing Technology

3

CHAPTER

This chapter describes how to install the printer driver, how to print and the functions of this printer.

Installing the CAPT	3-3
For Windows 98/Me	3-3
For Windows 2000	3-19
For Windows XP	3-29
Using the Printer on Your Network	3-38
Connecting the LBP-1120 as a Network Printer	3-38
Connecting to the LBP-1120 Already on Your Network	3-42
Canon LASER SHOT LBP-1120 Group	3-43
Uninstalling the CAPT	3-45
Printing a Document	3-47
Cancel the Print Job	3-48
Accessing the Properties Dialog Box	3-49
For Windows 98/Me	3-49
For Windows 2000/XP	3-49
Using the Printing Options	3-51
For Windows 98/Me	3-51
For Windows 2000/XP	3-57
Printing Multiple Pages on One Sheet	3-65
Scaling a Document	3-67
Selecting the Custom Paper Size Setting	3-69
Using the Overlay Printing	3-70
Specifying the Print Quality	3-73
Specifying the Toner Density	3-74
Using the Automatic Image Refinement	3-76
Using Profiles for Printing	3-77
Viewing the Printer Settings/Restoring the Default Settings	3-80
Checking the Status of a Print Job	3-81
Using the Status Window	3-81
Opening the Status Window	3-83
Closing the Status Window	3-83

Status Options. 3-84
Network Printer Status. 3-86

3

Installing the CAPT

If you are using the LBP-1120 as a local printer (connected directly to your computer), follow the procedure below to install the CAPT printing software. If the LBP-1120 is already on your network, and you want to start using it, see "Connecting to the LBP-1120 Already on Your Network," on p. 3-42. If you want to install the LBP-1120 as a network printer, see "Connecting the LBP-1120 as a Network Printer," on p. 3-38.

For Windows 98/Me

CD-ROM Installation

The screens shown in the instructions below are from Windows 98.

- 1 Turn off the printer.**
- 2 Turn on your computer and start up Windows 98/Me.**
- 3 Insert the User Software CD-ROM into your CD-ROM drive.**

[Canon LBP-1120 CD-ROM Menu] appears automatically.

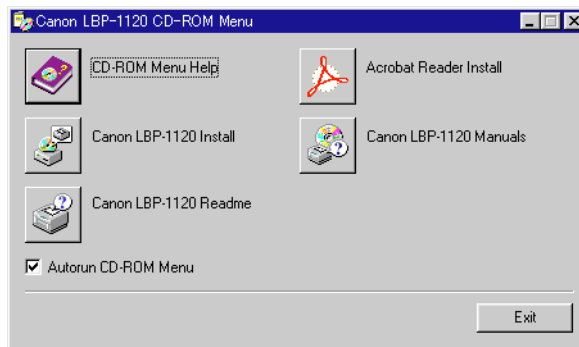

If the CD-ROM Menu does not appear automatically, start it manually, and check [Autorun CD-ROM Menu].

4 Click [Canon LBP-1120 Install].

5 The [Canon LBP-1120 Install] dialog box appears. Click [Yes] to install the CAPT in the language displayed.



The setup for the installation completes, and then installation of the CAPT (Canon Advanced Printing Technology) starts.

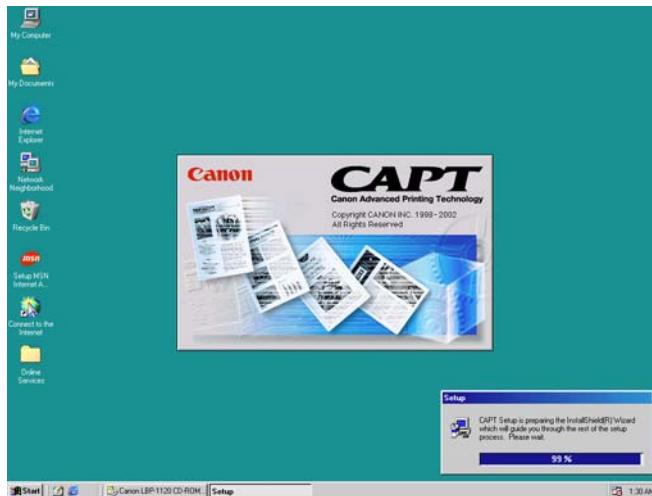

6 The [Welcome] screen appears. Click [Next].

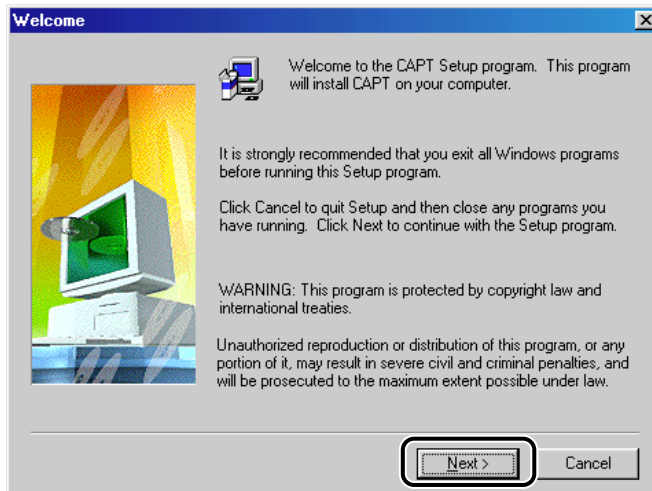

The [Software License Agreement] screen appears.

7 Check the contents of [Software License Agreement], and then click [Yes].

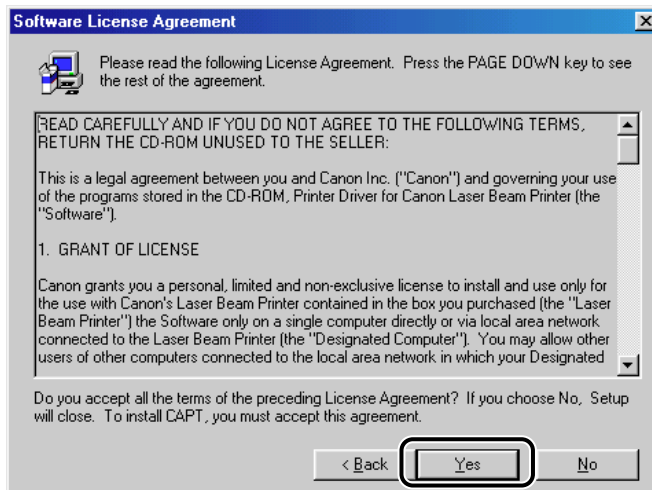

The [Select printer connection port] dialog box appears.

- 8** If USB port cannot be found in the port list, click [USB Port Setup].

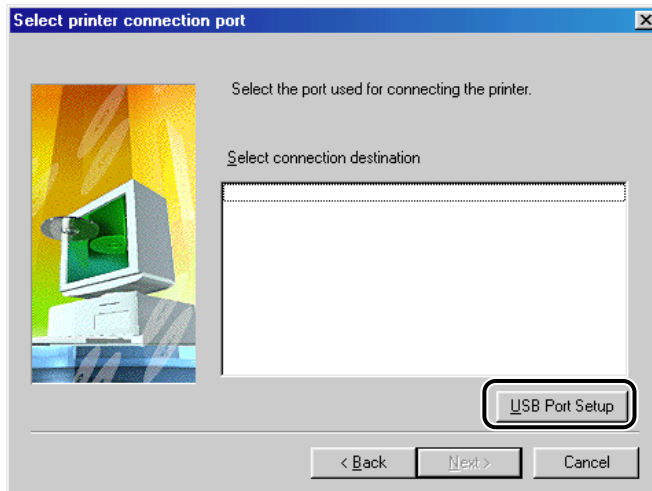

When the USB port can be found in the port list, go to step 13.

- 9** Click [Yes] to continue the setting up of the LBP-1120.

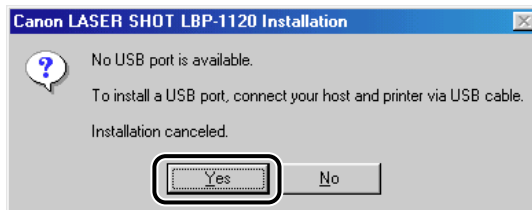

- 10** Connect the USB cable to the printer and your computer and turn on the printer.

For detailed information, see the *Getting Started Guide*.

USB port is automatically detected and the USB driver will be installed.

- 11** Click [Cancel] when the [Add New Hardware Wizard] dialog box appears.

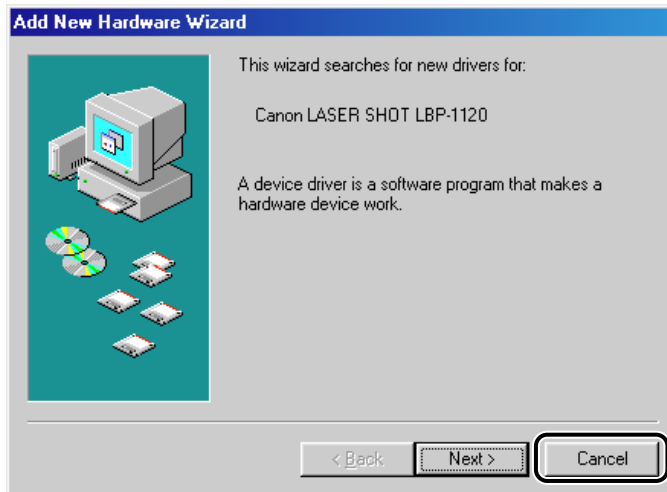

Unless you cancel, see the procedure for "Plug & Play," on p. 3-9.

- 12** Click [Canon LBP-1120 Install]. Repeat the procedure from step 5 to step 7.

- 13** Select a USB port, such as [USBPRN01] for Windows 98 or [USB001] for Windows Me from the port list, and then click [Next].

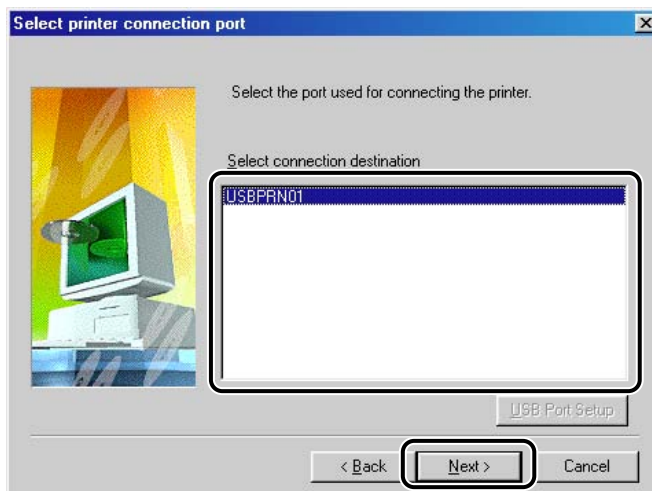

If [USBPRN01] or [USB001] is not displayed in the list, repeat from step 8.

14 A dialog box asking you to proceed with the installation appears. Press [Yes].

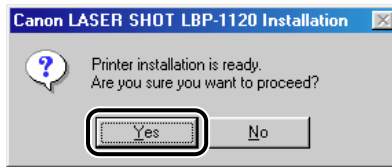

15 When the installation is complete, the following dialog box appears. Click [Finish] to close the dialog box.



Installation of the USB driver and the printer driver is complete.

Plug & Play

The screens shown in the instructions below are from Windows 98.

IMPORTANT

Before you install the software, make sure that you do the following:

- Connect the printer to your computer. (See the *Getting Started Guide*.)
- Turn on the printer. (See "Turning the Printer ON/OFF," on p. 1-7.)

1 Turn on your computer and start up Windows 98/Me.

The USB port is automatically detected.

The [Add New Hardware Wizard] dialog box appears. Click [Next].



- 2** Select [Search for the best driver for your device. (Recommended)] in the [Add New Hardware Wizard] dialog box and click [Next].



For Windows Me, select [Specify the location of the driver (Advanced)] and click [Next] in the [Add New Hardware Wizard] dialog box.

The dialog box to specify the location of the driver appears.

- 3** Insert the User Software CD-ROM into the CD-ROM drive.

4 Check only the [Specify a location] check box, and then click [Browse] to select the driver in the language that you want to install.

For example, if your CD-ROM drive is drive [D], browse to [D:\English\Win98], then click [OK].



For Windows Me, check only the [Specify the location] check box, and then click [Browse] to select the driver in the language that you want to install. For example, if your CD-ROM drive is drive [D], browse to [D:\English\WinMe], then click [OK].

5 Confirm that the folder to browse is selected under [Specify a location], then click [Next].

The screen displays the selected driver file.

6 Click [Next].



Installation of the USB driver starts.

7 Click [Finish].



The [Add New Hardware Wizard (Canon LASER SHOT LBP-1120)] dialog box appears.

8 Click [Next].



9 Repeat the procedure from step 2 to step 5.

10 Click [Next].



Installation of the printer driver starts.

- 11** Click [Finish] to accept the default printer name, or enter the name you wish to use, then click [Finish].

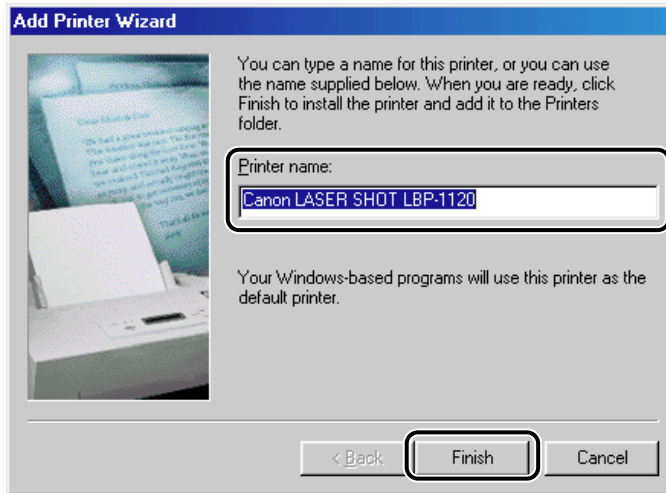

- 12** When the installation is complete, the following dialog box appears. Click [OK] to close the dialog box.



13 Click [Finish] in the [Add New Hardware Wizard] dialog box.



www.DataSheet4U.com

Installation of the USB driver and the printer driver is complete.

Add Printer Wizard

The screens shown in the instructions below are from Windows 98.

1 Click [Start], point to [Settings], and then click [Printers].

The [Printers] folder appears.

- 2** Double-click [Add Printer]. The [Add Printer Wizard] dialog box appears. Click [Next].

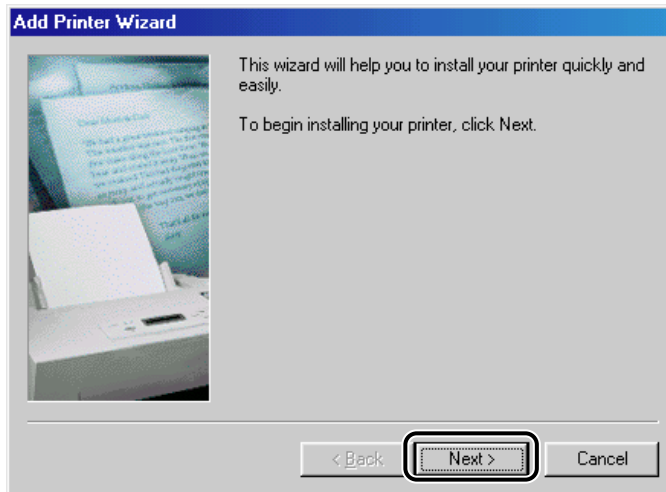

- 3** Select [Local printer] and click [Next].

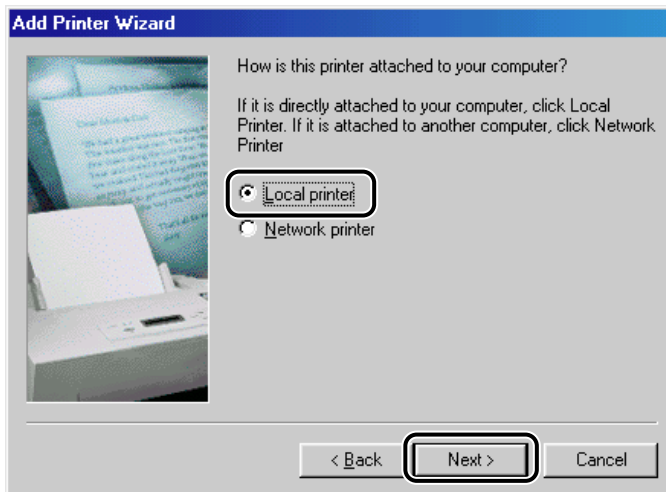

4 Click [Have Disk] in the [Manufacturers/Printers] dialog box.

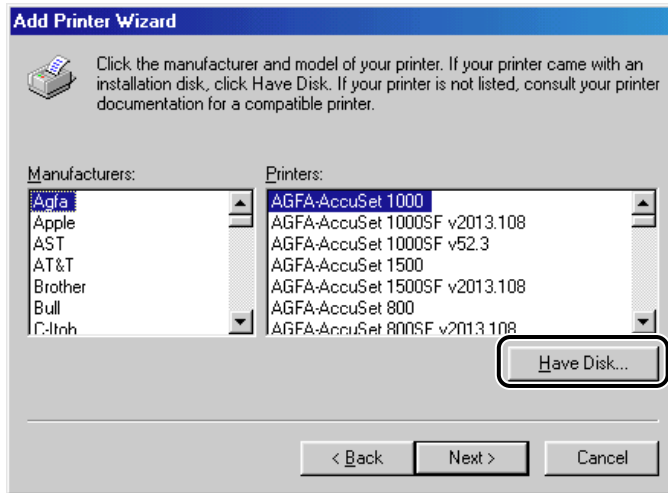

The [Install From Disk] dialog box appears.

5 Use [Browse] to select the directory or enter the path name that contains the CAPT, then click [OK].

For example, if you are using the CD-ROM to install the CAPT, and your CD-ROM drive is drive [D], the path name would be [D:\English\Win98].



6 Select your printer model from the list of printers displayed, then click [Next].

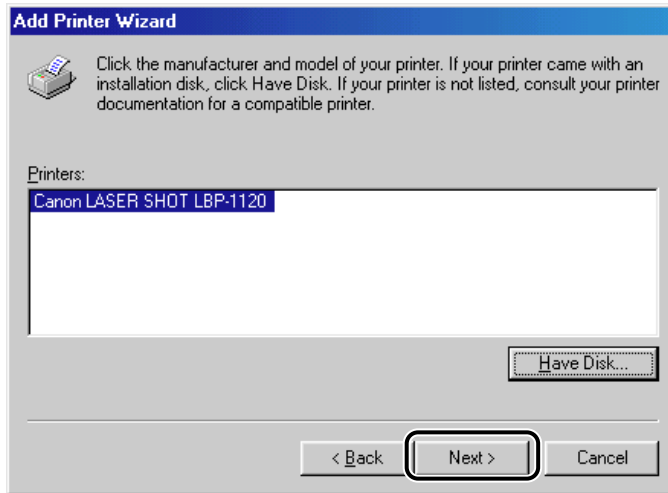

7 Select the printer port you want to use, and then click [Next].

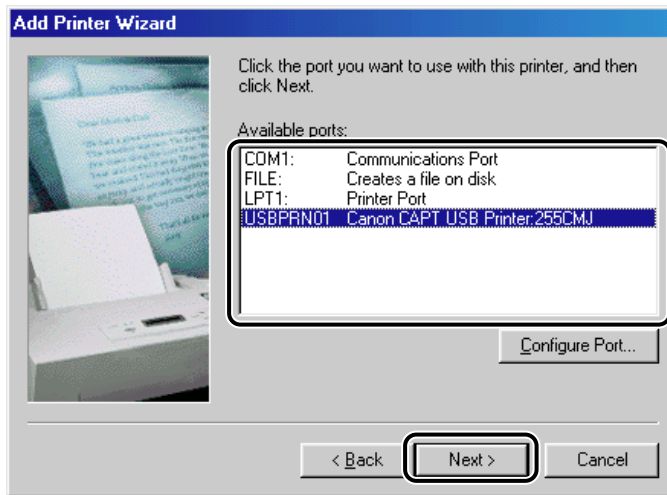

NOTE

Always select the USB port. If you select any other port, you cannot print.

- 8** Click [Finish] to accept the default printer name, or enter the name you wish to use, then click [Finish].

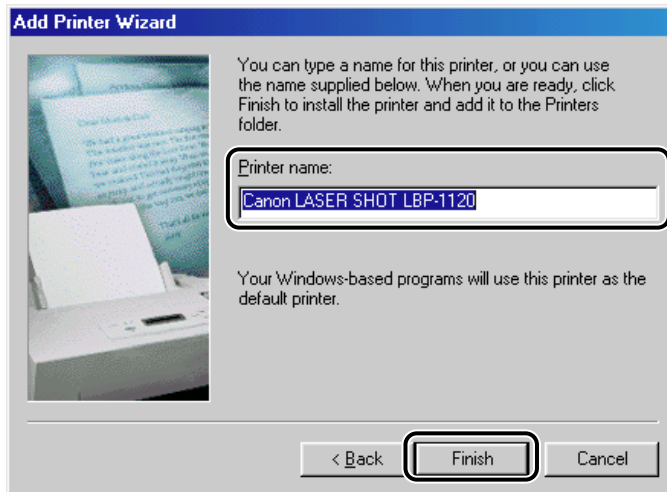

- 9** When the installation is complete, the following dialog box appears. Click [OK] to close the dialog box.



Windows creates the [Canon LASER SHOT LBP-1120] group folder on the Desktop, and the [Canon LASER SHOT LBP-1120] icon is added to the [Printers] folder.

For Windows 2000

Plug & Play



IMPORTANT

Before you install the software, make sure you that do the following:

- Connect the printer to your computer. (See the *Getting Started Guide*.)
- Turn on the printer. (See "Turning the Printer ON/OFF," on p. 1-7.)

1 Turn on your computer and start Windows 2000.

Plug & Play is being carried out and the USB driver, [USB Printing Support] is automatically detected and installed.

2 Log on as the Administrator.



NOTE

Full access rights are necessary for the installation of the CAPT.

3 The [Found New Hardware Wizard] dialog box appears. Click [Next].



3

- 4** Select [Search for a suitable driver for my device (recommended)] in the [Found New Hardware Wizard] dialog box and click [Next].

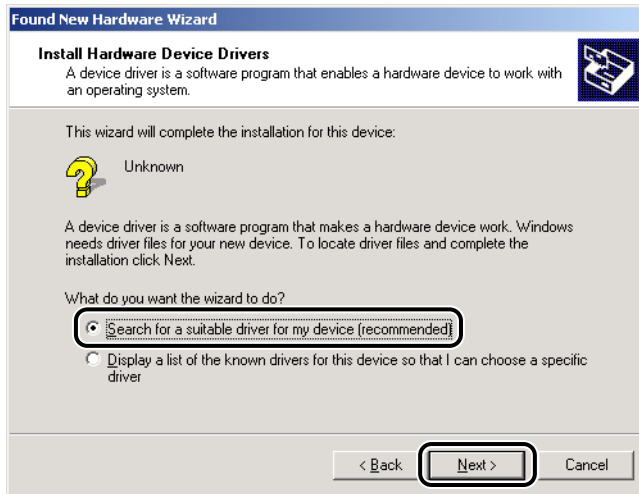
**NOTE**

[Unknown] may be displayed as the name of the device.

- 5** Check only the [Specify a location] check box and click [Next].

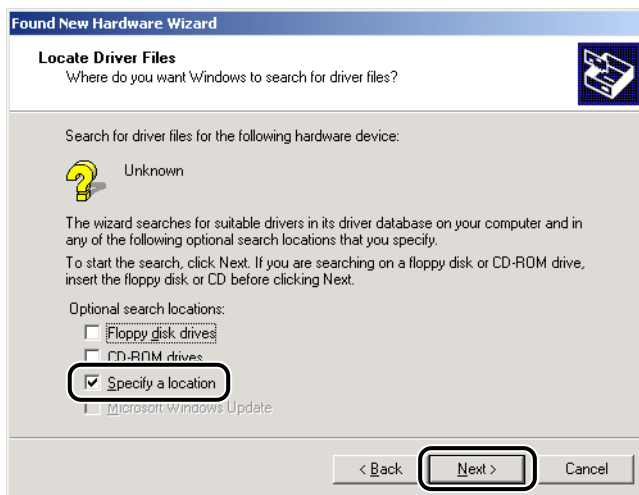

6 Insert the User Software CD-ROM into the CD-ROM drive and click [Browse] to select the driver in the language that you want to install.

For example, if your CD-ROM drive is drive [D], browse to [D:\English\Win2000], then click [OK].

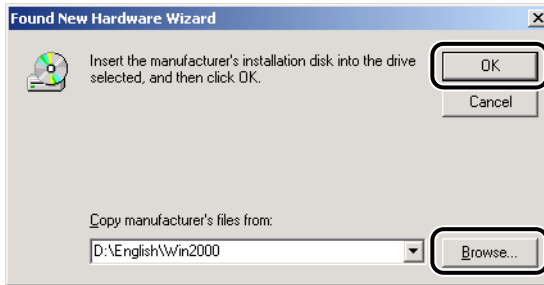

7 Click [Next] on [Driver Files Search Results].

Click [Yes] if the [Digital Signature Not Found] dialog box appears.

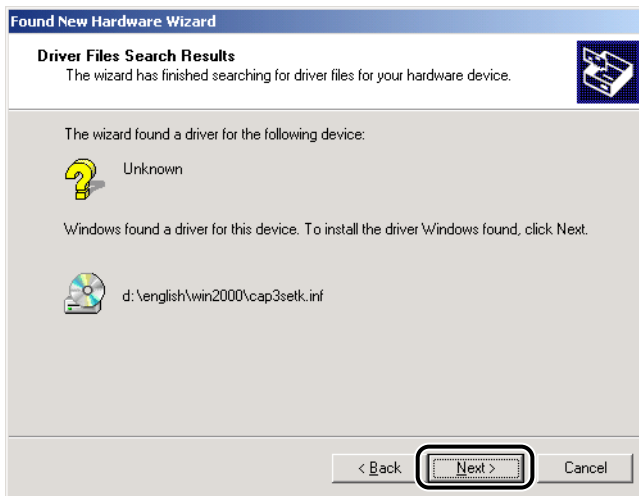

8 When installation is complete, the following dialog box appears. Click [OK] to close the dialog box.

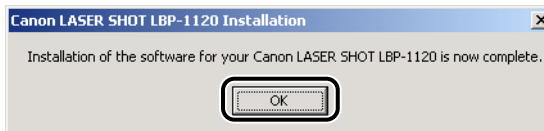

- Click **[Finish]** on the **[Found New Hardware Wizard]** dialog box.

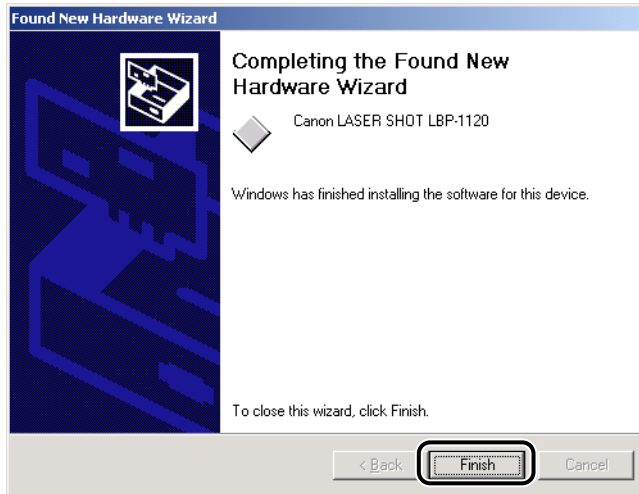

Installation of the USB driver and the printer driver is complete.

Add Printer Wizard

- 1** Log on as the Administrator.



NOTE

Full control access rights are necessary for the installation of the CAPT.

- 2** Click **[Start]**, point to **[Settings]**, and then click **[Printers]**.

The **[Printers]** folder appears.

- 3** Double-click [Add Printer]. The [Add Printer Wizard] dialog box appears. Click [Next].

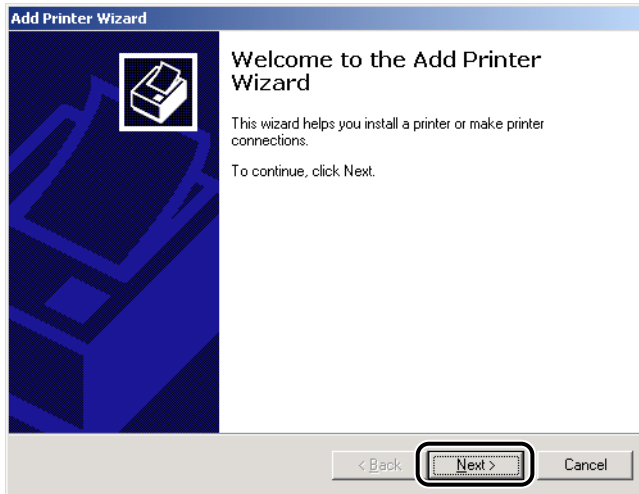

- 4** Select [Local printer] and click [Next].

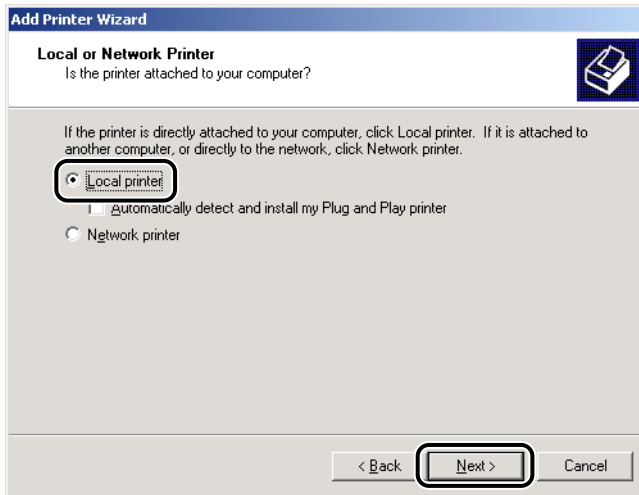

NOTE

Placing a check in the [Automatically detect and install my Plug and Play printer] check box is not recommended.

5 Select the printer port you want to use, then click [Next].

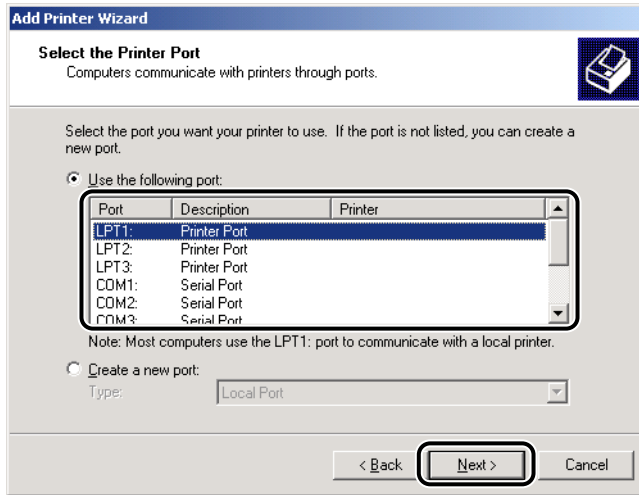

 **NOTE**
Always select the USB port. If you select any other port, you cannot print.

6 Click [Have Disk] in the [Manufacturers/Printers] dialog box.

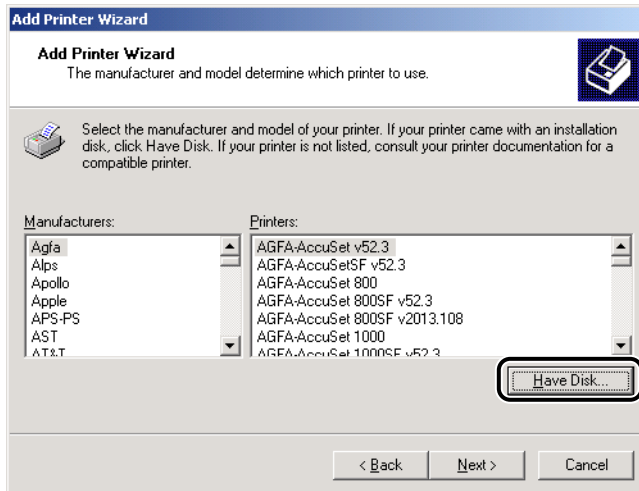

The [Install From Disk] dialog box appears.

7 Use [Browse] to select the directory or enter the path name that contains the CAPT, then click [OK].

For example, if you are using the CD-ROM to install the CAPT, and your CD-ROM drive is drive [D], the path name would be [D:\English\Win2000].

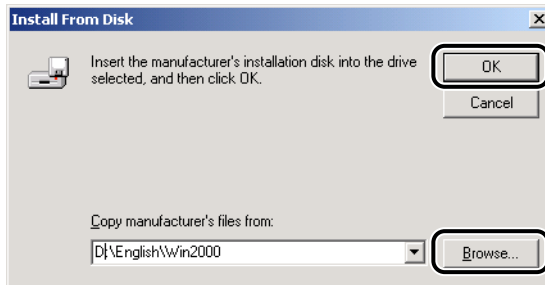

8 Select your printer model from the list of printers displayed, then click [Next].

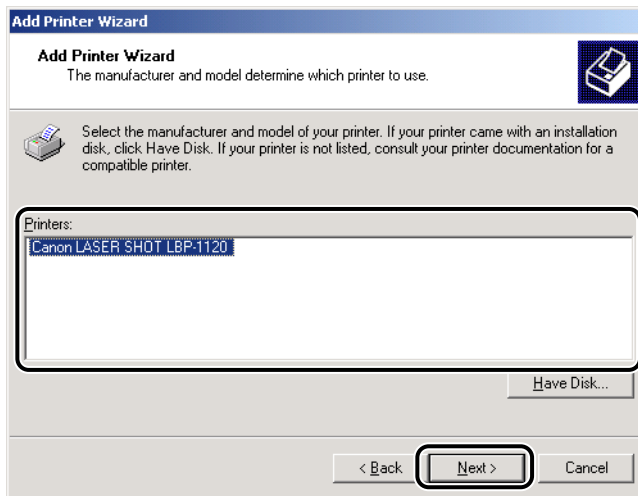

- 9** Click [Next] to accept the default printer name, or enter the name you wish to use, then click [Next].

The screenshot shows the 'Add Printer Wizard' dialog box with the title 'Add Printer Wizard'. The main heading is 'Name Your Printer' with a sub-heading 'You must assign a name for this printer.' and a printer icon. Below this, it says 'Supply a name for this printer. Some programs do not support server and printer name combinations of more than 31 characters.' There is a text input field labeled 'Printer name:' containing the text 'Canon LASER SHOT LBP-1120'. At the bottom, there are three buttons: '< Back', 'Next >', and 'Cancel'. The 'Next >' button is highlighted with a black border.

- 10** Select whether this printer is shared or not shared with other computers. Click [Next].

The screenshot shows the 'Add Printer Wizard' dialog box with the title 'Add Printer Wizard'. The main heading is 'Printer Sharing' with a sub-heading 'You can share this printer with other network users.' and a printer icon. Below this, it says 'Indicate whether you want this printer to be available to other users. If you share this printer, you must provide a share name.' There are two radio button options: 'Do not share this printer' (which is selected) and 'Share as:'. The 'Share as:' option has an empty text input field next to it. At the bottom, there are three buttons: '< Back', 'Next >', and 'Cancel'. The 'Next >' button is highlighted with a black border.

- 11** Click [Yes] if you want to print a test page, or [No] if you do not want to print a test page, then click [Next].

12 Click [Finish].

Click [Yes] if the [Digital Signature Not Found] dialog box appears.

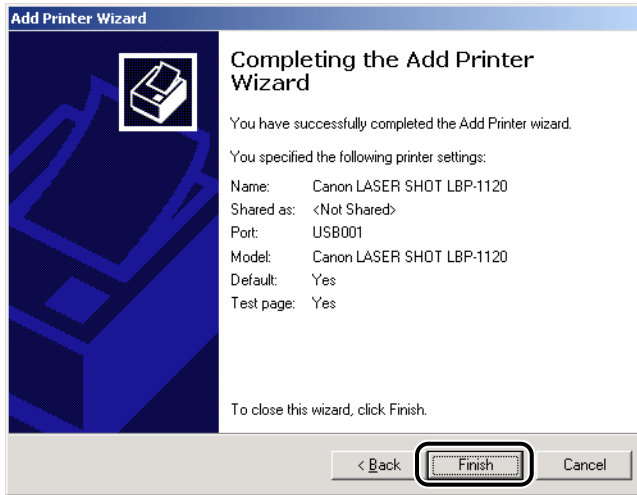

13 When the installation is complete, the following dialog box appears. Click [OK] to close the dialog box.

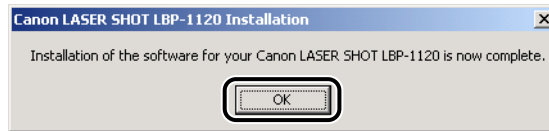

Windows creates the [Canon LASER SHOT LBP-1120] group folder on the Desktop, and the [Canon LASER SHOT LBP-1120] icon is added to the [Printers] folder.

14 If you opted to print a test page, the page prints after installation completes, and the following dialog box appears. If the page printed correctly, click [OK].

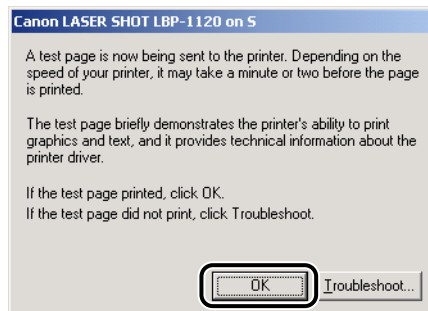

Plug & Play



IMPORTANT

Before you install the software, make sure you do the following:

- Connect the printer to your computer. (See the *Getting Started Guide*.)
- Turn on the printer. (See "Turning the Printer ON/OFF," on p. 1-7.)

1 Turn on your computer and start Windows XP.

Plug & Play is being carried out and the USB driver, [USB Printing Support] is automatically detected and installed.

2 Log on as the Administrator.



NOTE

Full access rights are necessary for the installation of the CAPT.

3 The [Found New Hardware Wizard] dialog box appears. Insert the User Software CD-ROM into your CD-ROM drive.

4 Select [Install from a list or specific location (Advanced)] and click [Next].





NOTE

[Unknown] may be displayed as the name of the device.

5 Uncheck [Search removable media (floppy, CD-ROM)].

6 Select [Include this location in the search], and click [Browse] to select the driver in the language that you want to install.

For example, if your CD-ROM drive is drive [D], browse to [D:\English\WinXP], then click [Next].

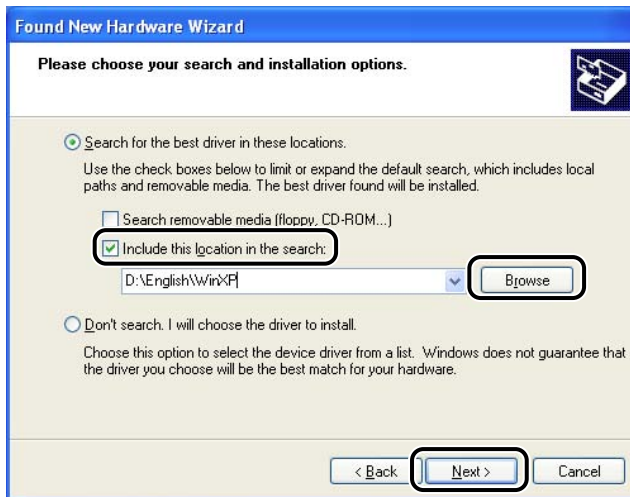

Click [Continue Anyway] if the [Hardware Installation] dialog box appears.

7 When the installation is complete, the following dialog box appears. Click [OK] to close the dialog box.



- 8 Click [Finish] on the [Found New Hardware Wizard] dialog box.



Installation of the USB class driver and the printer driver is complete.

Add Printer Wizard

- 1 Log on as the Administrator.



NOTE

Full access rights are necessary for the installation of the CAPT.

- 2 From the [Start] menu, select [Printers and Faxes].

The [Printers and Faxes] folder appears.

- 3** Double-click [Add a printer]. The [Add Printer Wizard] dialog box appears. Click [Next].



- 4** Select [Local printer attached to this computer], then click [Next].



NOTE

Placing a check in the [Automatically detect and install my Plug and Play printer] check box is not recommended.

- 5** Confirm that [Use the following port] is selected and select the printer port you want to use, then click [Next].

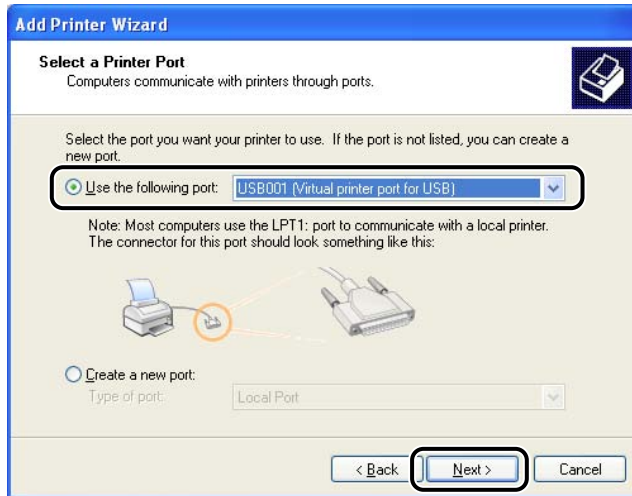

NOTE

Always select the USB port. If you select any other port, you cannot print.

- 6** Click [Have Disk] in the [Manufacturer/Printers] dialog box.

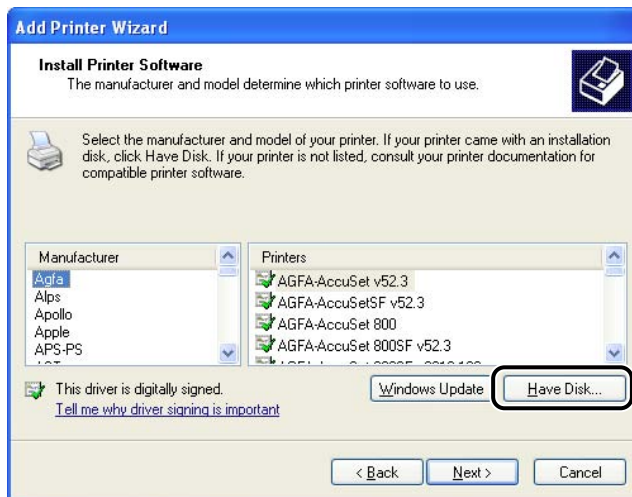

The [Install From Disk] dialog box appears.

7 Use [Browse] to select the directory or enter the path name that contains the CAPT, then click [OK].

For example, if you are using the CD-ROM to install the CAPT, and your CD-ROM drive is drive [D], the path name would be [D:\English\WinXP].



8 Select your printer model from the list of printers displayed, then click [Next].

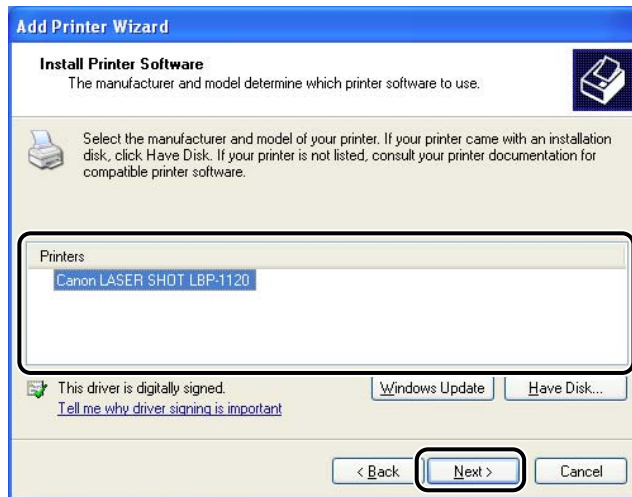

- 9** Click [Next] to accept the default printer name, or enter the name you wish to use, then click [Next].

Add Printer Wizard

Name Your Printer
You must assign a name to this printer.

Type a name for this printer. Because some programs do not support printer and server name combinations of more than 31 characters, it is best to keep the name as short as possible.

Printer name:
Canon LASER SHOT LBP-1120

Do you want to use this printer as the default printer?

Yes
 No

< Back Next > Cancel

- 10** Select whether this printer is shared or not shared with other computers. Click [Next].

Add Printer Wizard

Printer Sharing
You can share this printer with other network users.

If you want to share this printer, you must provide a share name. You can use the suggested name or type a new one. The share name will be visible to other network users.

Do not share this printer
 Share name: _____

< Back Next > Cancel

- 11** Click [Yes] if you want to print a test page, or [No] if you do not want to print a test page, then click [Next].

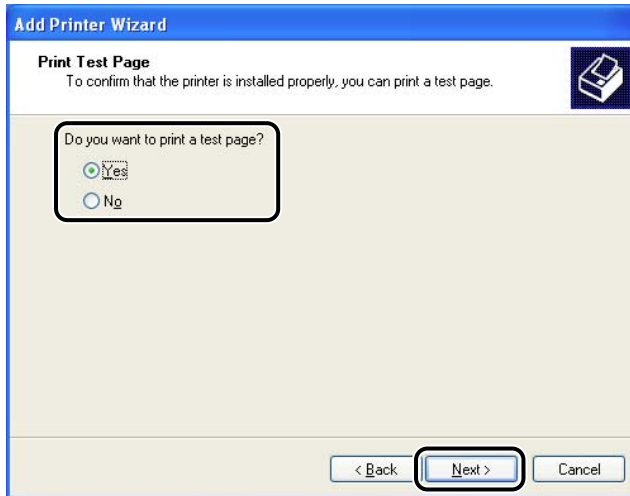

- 12** Click [Finish].

Click [Continue Anyway] if the [Hardware Installation] dialog box appears.



Windows creates the [Canon LASER SHOT LBP-1120] group folder on the Desktop, and the [Canon LASER SHOT LBP-1120] icon is added to the [Printers and Faxes] folder.

- 13** When the installation is complete, the following dialog box appears. Click [OK] to close the dialog box.

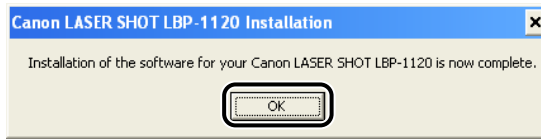

- 14** If you opted to print a test page, the page prints after installation completes, and the following dialog box appears. If the page printed correctly, click [OK].

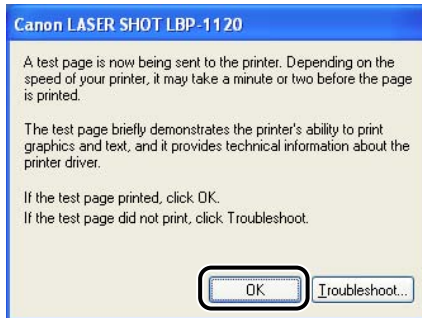

Using the Printer on Your Network

You can use the LBP-1120 as a network printer, which enables printing from the computers over a network. The computer that is directly connected to the printer is called "print server", and the computers that can use the printer over the network are called "clients". The print server and clients do not need to use the same operating system, and it is possible to print from a Windows 98/Me client to a Windows 2000/XP printer server, or vice versa.



IMPORTANT

Using the LBP-1120 on your network requires that both the print server and the client devices are using Windows 98 or later.



NOTE

- Even if the server was not running when the client was started, you can start printing simply by starting the server.
- If the server is running on Windows 2000/XP, you can print even if no one is logged into the server. However there is no status display on the server when no one is logged in. The display is shown on the client.

Connecting the LBP-1120 as a Network Printer

If you plan to share the LBP-1120 on a network, install the print server locally, then make the following settings. For detailed information, see your print server system documentation.

Windows 98/Me Server Settings

■ Network Settings

- 1** Double-click [Network] in [Control Panel].
- 2** Select the [Configuration] tab, and then click [Add].
- 3** Select [Service], and then click [Add].
- 4** Select [Microsoft] in the [Manufacturers] list box.
- 5** Select [File and printer sharing for Microsoft Networks] in the [Network Services] box, and then click [OK].
- 6** Click [File and Print Sharing].
 **NOTE**
Be sure there is a check in the [I want to be able to allow others to print to my printer(s)] check box.
- 7** Select the [Access Control] tab and check either [Share-level access control] or [User-level access control].
- 8** Click [OK], and then restart Windows.

■ *Printer Settings*

■ *Share-level Access Control*

- 1** Open the [Canon LASER SHOT LBP-1120 Properties] dialog box, then check [Shared As] in the [Sharing] tab.
- 2** Enter [Share Name], [Comment], and [Password] as needed.
- 3** Click [OK].

■ *User-level Access Control*

- 1** Open the [Canon LASER SHOT LBP-1120 Properties] dialog box, then check [Shared As] in the [Sharing] tab.
- 2** Enter [Share Name] and [Comment] as needed.
- 3** Click [Add], and select the users allowed to access the printer.
- 4** Click [OK] when you are done adding users.
- 5** Click [OK] again.



NOTE

Do not enter a space or special characters in [Share Name].

Windows 2000/XP Server Settings

■ *Add Server Service (Windows 2000)*

- 1** Click [Start], point to [Settings], and then click [Network and Dial-up Connections].

The [Network and Dial-up Connections] folder appears.

- 2** Right-click [Local Area Connection], then select [Properties] from the pop-up menu.

The [Local Area Connection Properties] dialog box appears.

- 3** Select [File and Printers Sharing for Microsoft Networks], then click [OK].

■ Add Server Service (Windows XP)

- 1** Click [Network and Internet Connections] in [Control Panel].

- 2** Click [Network Connections].

- 3** Right-click [Local Area Connection], then select [Properties] from the menu.

The [Local Area Connection Properties] dialog box appears.

- 4** If [File and Printer Sharing for Microsoft Networks] exists in the list, click [OK]. Otherwise, click [Install].

- 5** Select [Service], then click [Add].

- 6** Select [File and Printer Sharing for Microsoft Networks] in the [Network Services] box, then click [OK].

- 7** Click [Close].

■ *Printer Sharing Settings (Windows 2000/XP)*

- 1** Open the [Canon LASER SHOT LBP-1120 Properties] dialog box, then check [Shared as] in the [Sharing] tab.
- 2** Enter the share name as needed.
- 3** Click [OK].

The printer icon changes to indicate sharing.



NOTE

Sharing settings may also be made during installation.

3

Connecting to the LBP-1120 Already on Your Network

If the LBP-1120 is already on your network, you can install it in two different ways. The easiest way is using automatic network download. If network download is not available, you can use the Add Printer Wizard.



NOTE

If you want to use the Add Printer Wizard to install the printer driver, perform the same procedure as "CD-ROM Installation," on p. 3-3 or "Plug & Play," on p. 3-9.

Network Download

Windows 98/Me and Windows 2000/XP clients can download the drivers for the LBP-1120 automatically.

- 1** Open [Explorer] and browse the network until you can see the [Canon LASER SHOT LBP-1120] printer icon.
- 2** Double-click the printer icon, or drag the printer icon to your [Printers] folder.
- 3** Follow the instructions on screen.



NOTE

Windows 2000/XP clients cannot download the driver from Windows 98/Me servers.

Canon LASER SHOT LBP-1120 Group

When you install the CAPT, the [Canon LASER SHOT LBP-1120] icon is created in the [Printers] folder, and the [Canon LASER SHOT LBP-1120] group folder is created on the Desktop. The [Canon LASER SHOT LBP-1120] group is also added in [Programs] of the [Start] menu.

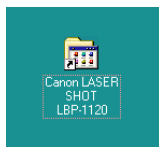
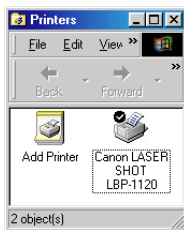

When you double-click on the [Canon LASER SHOT LBP-1120] folder, the icons of the [Canon LASER SHOT LBP-1120] group are displayed.

■ Canon LASER SHOT LBP-1120 Uninstallation

Starts the uninstall program for the CAPT. If the CAPT is not working properly, it might help to uninstall and then install it again. (See "Uninstalling the CAPT," on p. 3-45.)

■ Canon LASER SHOT LBP-1120 Status Window

Printing status and the printer's status will be shown by animations and sound. There are also functions that allow you to pause and delete printing. To open the Status Window, click the Status Window icon on the Windows taskbar, and then select [Canon LASER SHOT LBP-1120] from the pop-up menu displayed. (See "Opening the Status Window," on p. 3-83.)

■ **Canon LASER SHOT LBP-1120 Trouble Shooter**

Starts the Trouble Shooter program for the CAPT. It helps you solve printing problems in Windows 98/Me or 2000/XP. (See "Using the Trouble Shooter," on p. 5-19.)

■ **Canon LASER SHOT LBP-1120 Help**

Selects the Canon LBP-1120 Help file for the CAPT.

Uninstalling the CAPT

If the CAPT is not working properly, it might help to remove it and install it again. Before you begin, be sure you have the installation software available for installation.

To uninstall the CAPT, follow the procedure below.



IMPORTANT

Before uninstalling the CAPT, all running applications must be closed.

1 Make sure that you close all running applications.

2 Open the [Canon LASER SHOT LBP-1120] folder on the Desktop, and then double-click [Canon LASER SHOT LBP-1120 Uninstallation].

The [Canon LASER SHOT LBP-1120 Uninstallation] dialog box appears.

3 Click [OK].

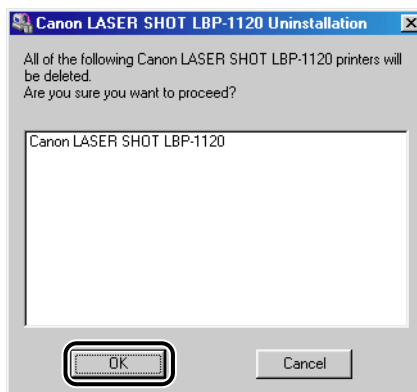

Uninstallation is carried out, and the dialog box to prompt you to restart Windows appears when uninstallation is complete.

4 Click [OK].



Windows is restarted.



NOTE

- To remove the USB port, see the *Getting Started Guide*.
- When the software is not installed correctly and you need to reinstall it, uninstall first, and then install it again.
- In Windows 2000/XP, you cannot uninstall the CAPT unless you have administrative privileges.

Printing a Document

To print a document, follow the procedure below.

1 In the application, with the document open, select [Print] to print your document.

2 In the [Print] dialog box, select your printer name from [Name], and then click [Properties].

The Properties dialog box opens.

3 Specify the various print settings in the Properties dialog box. To switch between sheets, click the tabs for the [Page Setup], [Finishing], and [Quality] sheets.

You can also specify the various print settings, by selecting a profile.



NOTE

For detailed information on using the print options, see "Using the Printing Options," on p. 3-51 or the online help.

4 After all the print settings have been specified, click [OK] in the Properties dialog box.

5 Click [OK] in the [Print] dialog box.

The document is printed under the settings you specified.

Cancel the Print Job

You can cancel the current print job on the Canon LBP-1120 Status Window. To cancel the print job, follow the procedure below.

1 Start printing.

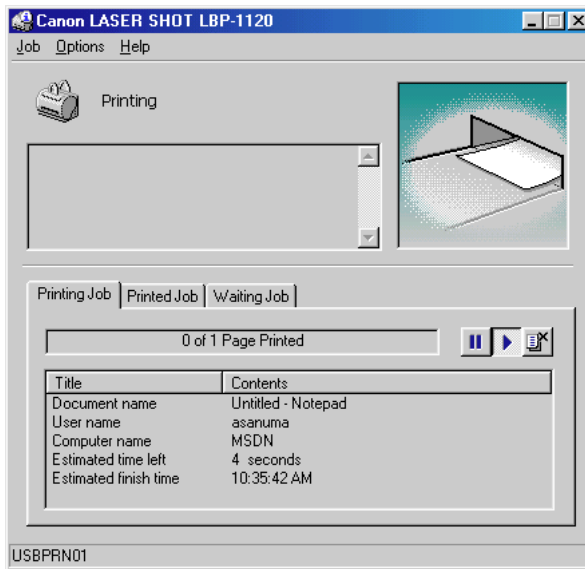

The Status Window appears.

2 Click the button on the toolbar.

You can perform other print job operations on the Status Window.



Temporarily halts printing the current document.



Continues printing after a pause.

Accessing the Properties Dialog Box

The Properties dialog box of the printer driver contains several sheets that enable you to set up and control your printer. To access the Properties dialog box, follow the procedure below for your version of Windows.

For Windows 98/Me

If you access the [Printer Properties] dialog box from the application, the specified settings are available for the current print job.

If you access the [Printer Properties] dialog box from the [Printers] folder, you can set up the printer configuration or specify your printer driver settings for every print job.

Accessing the Printer Properties Dialog Box from the Application

- 1** In the application, select [Print] to display the [Print] dialog box.
- 2** Select your printer name from the drop-down list box, and then click [Properties].

Accessing the Printer Properties Dialog Box from the Printers Folder

- 1** Click [Start], point to [Settings], and then click [Printers].
- 2** In the [Printers] folder, right-click the printer icon for your printer, and then click [Properties].

For Windows 2000/XP

The CAPT for Windows 2000/XP has two main Properties dialog boxes: the [Printer Properties] dialog box and [Printing Preferences] dialog box.

In the [Printing Preferences] dialog box, you can specify the printer driver settings. In the [Printer Properties] dialog box, you can set up the printer configuration.

Accessing the Printing Preferences Dialog Box from the Application

If you access the [Printing Preferences] dialog box from the application, the specified settings are available for the current print job.

- 1** In the application, select [Print] to display the [Print] dialog box.
- 2** Select your printer name from the drop-down list box, and then click [Properties].

Accessing the Printing Preferences Dialog Box from the Printers Folder

If you access the [Printing Preferences] dialog box from the [Printers] folder, you can specify the printer driver settings for every print job.

 **NOTE**

To access the [Printing Preferences] dialog box from the [Printers] folder, you need full access rights for the printer. If you cannot access the [Printing Preferences] dialog box from the [Printers] folder, access it from the application.

- 1** Click [Start], point to [Settings], and then click [Printers].
- 2** In the [Printers] folder, right-click the printer icon for your printer, and then click [Printing Preferences].

Accessing the Printer Properties Dialog Box from the Printers Folder

You can set up the printer configuration in the [Printer Properties] dialog box.

- 1** Click [Start], point to [Settings], and then click [Printers].
- 2** In the [Printers] folder, right-click the printer icon for your printer, and then click [Properties].

Using the Printing Options

You can specify a variety of printer settings in the Properties dialog box. When you open the Properties dialog box, you will find several tabs. You can switch between sheets by clicking the tabs, and then specify the settings inside the displayed sheet.

 NOTE

The number of tabs displayed in the Properties dialog box depends on how you have your system set up.

This section explains the printing options you can set up in the Properties dialog box, and provides instructions for specifying the various settings for printing a document.

 NOTE

For more information about the following features, see the online help. To display the online help, select the item you want more information about and press [F1], or click [?] in the title bar and then select the item of interest.

For Windows 98/Me

Screens examples are Windows 98.

General Tab

Lets you print a test page or define separator pages. Refer to your operating system documentation for further instructions.

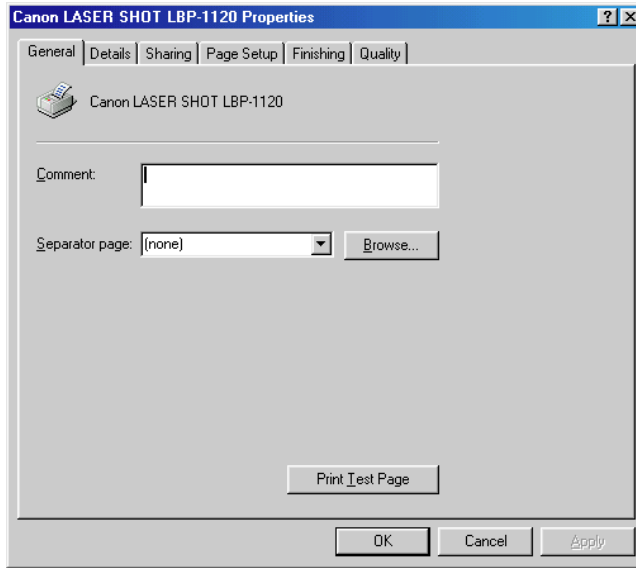

Details Tab

Specifies the printer port and time-out settings. Refer to your operating system documentation for further instructions.

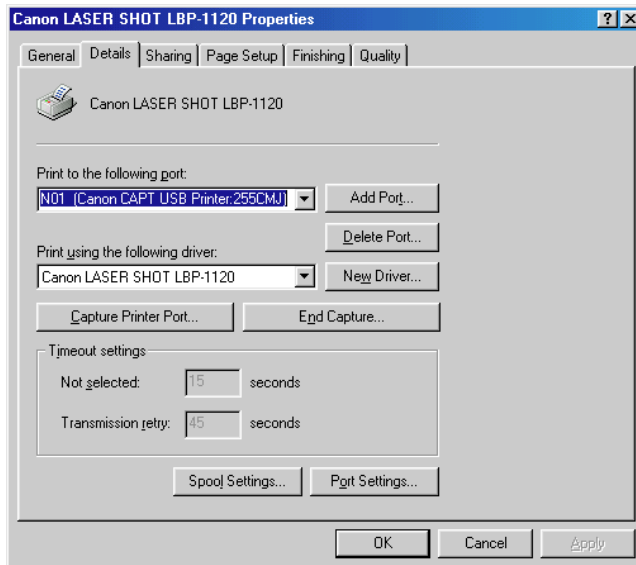

Sharing Tab

Specifies the printer sharing-settings. This tab is available only when file and printer sharing is turned on. Refer to your operating system documentation for further instructions.

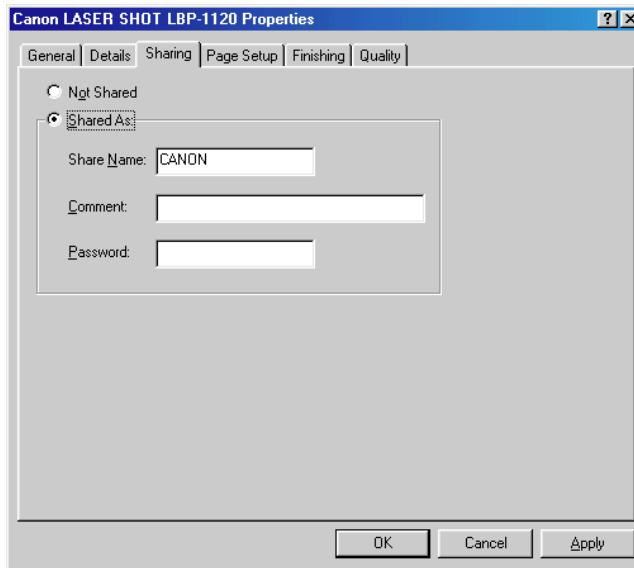

Page Setup Tab

Specifies the printer settings described below.

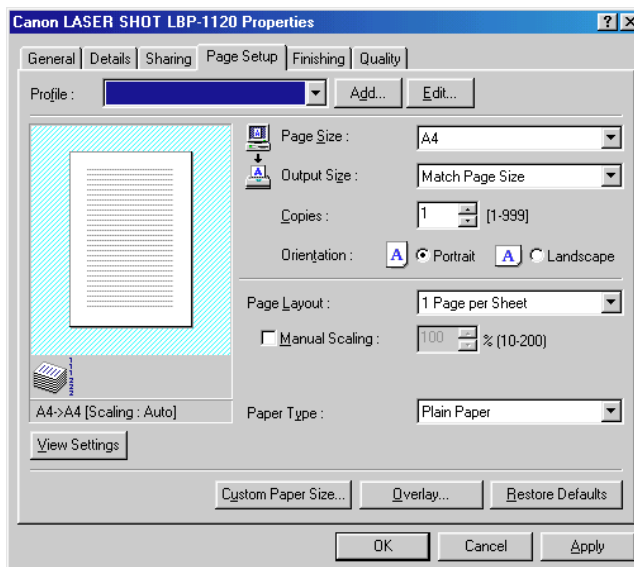

Profile

Lets you select the printer driver settings saved as profiles. (See "Using Profiles for Printing," on p. 3-77.)

Page Size

Lets you select the paper size you are working with in your application. (Letter, Legal, A4, B5, Executive, Envelope DL, Envelope #10, Envelope C5, Envelope Monarch, Index Card, and 3 custom paper sizes. The names for custom paper sizes can be defined by users.)

Output Size

Lets you select the paper size to print on.

 **NOTE**

- Select [Match Page Size], if you want to print in the paper size you are working with in your application.
- If your output size is anything other than [Match Page Size], the image will be automatically reduced or enlarged to fit on the page.

Copies

Lets you specify the number of copies to be printed (1 - 999).

Orientation

Lets you select the direction of printing relative to the paper (Portrait, Landscape).

Page Layout

Lets you select the number of pages to print per sheet (1, 2, 4, 8, 9). When you select more than 1, the image may be reduced to fit on the selected output size. (See "Printing Multiple Pages on One Sheet," on p. 3-65.)

Manual Scaling/Page Order

Lets you shrink or enlarge images. This option only appears when [1 Page per Sheet] is selected as the page layout. (See "Scaling a Document," on p. 3-67.) When 2, 4, 8 or 9 per sheet is selected in [Page Layout], [Page Order] appears. You can specify the required page order for printing multiple pages.

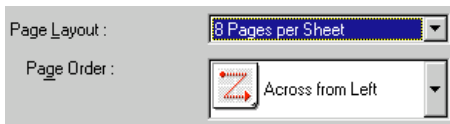
**Paper Type**

Displays the [Paper Type] pull-down menu and lets you select the appropriate paper type to print on. The paper types you can select are as follows:

- Plain Paper: Transparencies, label sheets, and plain paper (64 - 90 g/m²)
- Heavy Paper: Plain paper (91 - 135 g/m²), and bond paper (90 g/m²)
- Heavy Paper High: Postcards, envelopes and custom paper with a width less than or equal to 182 mm

 NOTE

If you are using a postcard, envelope, or custom size paper with a width less than 182 mm, the driver will print it as [Heavy Paper High], even when [Plain Paper] or [Heavy Paper] is specified.

View Settings

Displays the list of your current printer settings. (See "Viewing the Printer Settings," on p. 3-80.)

Custom Paper Size

Allows you to define custom paper sizes (forms) for quick selection. (See "Selecting the Custom Paper Size Setting," on p. 3-69.)

Overlay

Allows you to add data you use often, such as a logo, to the print data from an application. (See "Using the Overlay Printing," on p. 3-70.)

www.DataSheet4U.com

Finishing Tab

Specifies whether final output is collated. Check the [Collate] check box to collate the printouts.

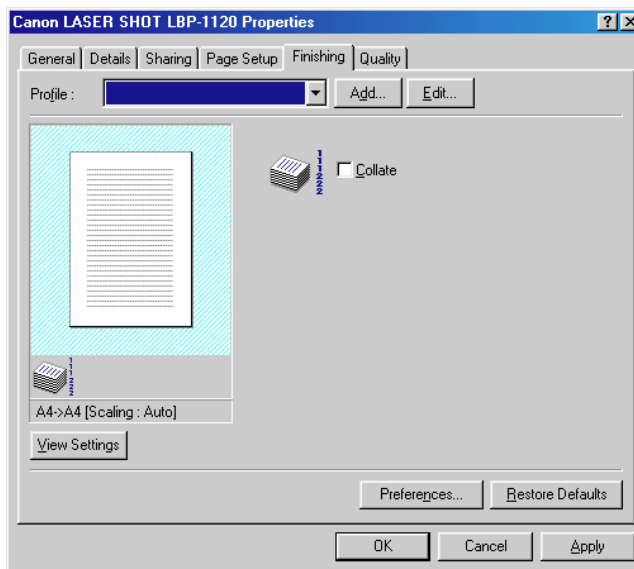

■ Preferences

[Preferences] on the [Finishing] sheet opens the [Preferences] dialog box as shown below.

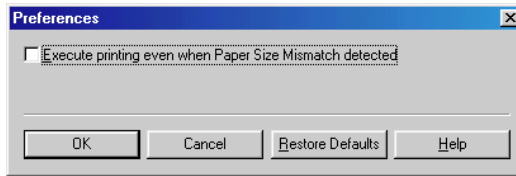

Execute printing even when Paper Size Mismatch detected

The check box lets you force pages to print, even when the paper size does not match. If this is not checked, you will be asked to change paper when a paper size mismatch is detected.

Quality Tab

Specifies the resolution, halftoning method, brightness, and contrast settings.

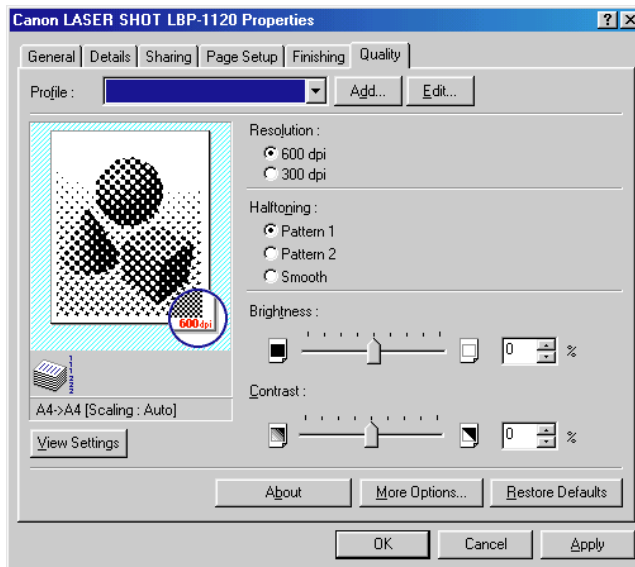

Resolution

Lets you specify the printer's resolution in dots per inch (600, 300). (See "Specifying the Print Quality," on p. 3-73.)

Halftoning

Lets you specify the halftoning methods (Pattern 1, Pattern 2, and Smooth). (See "Specifying the Print Quality," on p. 3-73.)

Brightness

Lets you specify the relative proportion of the light and dark areas of an image in the range from -80% to +80%. (See "Specifying the Print Quality," on p. 3-73.)

Contrast

Adjusts the degree of difference between the lightest and darkest areas of an image. (See "Specifying the Print Quality," on p. 3-73.)

More Options

Accesses the settings for [Toner Density], [Toner Saver], and [Automatic Image Refinement]. (See "Specifying the Toner Density," on p. 3-74 and "Using the Automatic Image Refinement," on p. 3-76.)

For Windows 2000/XP

Screens examples are Windows 2000.

www.DataSheet4U.com

General Tab

Lets you print a test page, or display the [Printing Preferences] dialog box to specify the printer driver settings. Refer to your operating system documentation for further instructions.

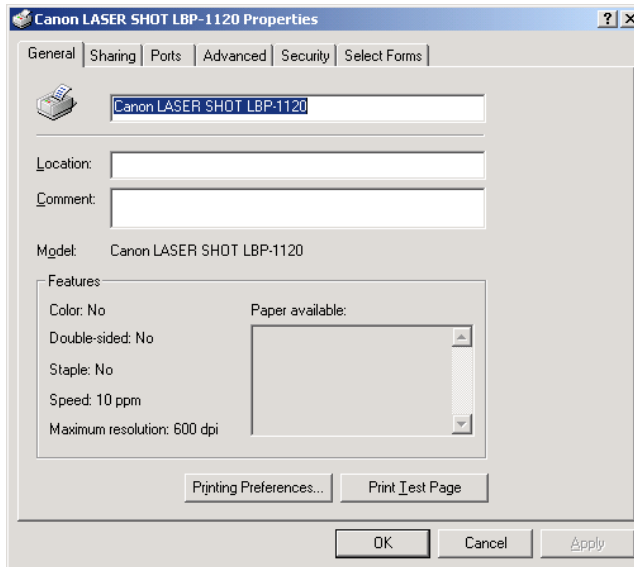

Sharing Tab

Specifies the printer sharing-settings. Refer to your operating system documentation for further instructions.

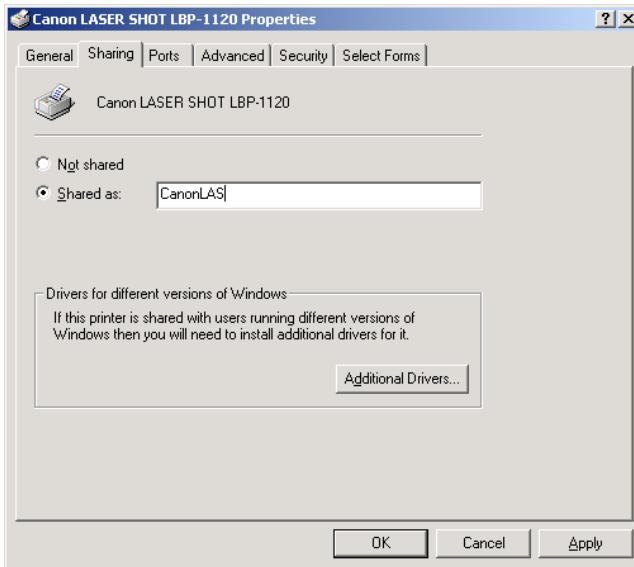

Ports Tab

Specifies the port to which the printer is attached. Refer to your operating system documentation for further instructions.

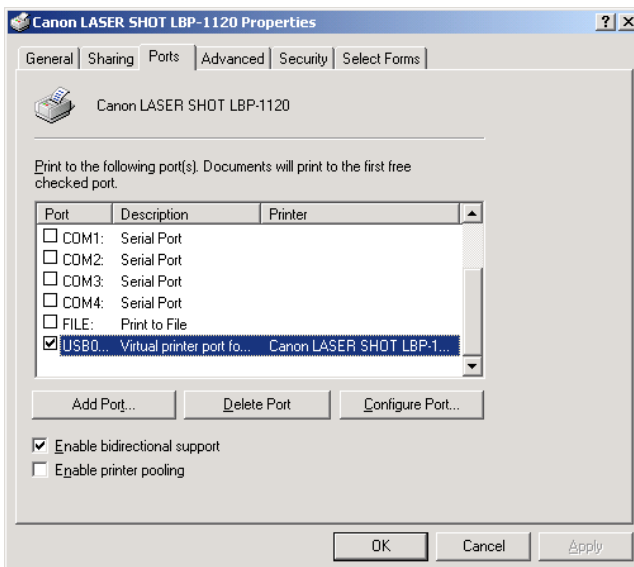

Advanced Tab

Lets you define print spool settings. Refer to your operating system documentation for further instructions.

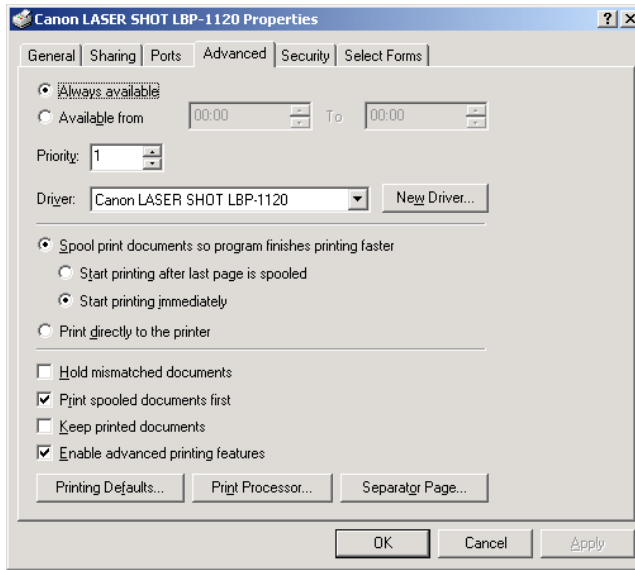

Security Tab

Lets you specify security settings. Refer to your operating system documentation for further instructions.

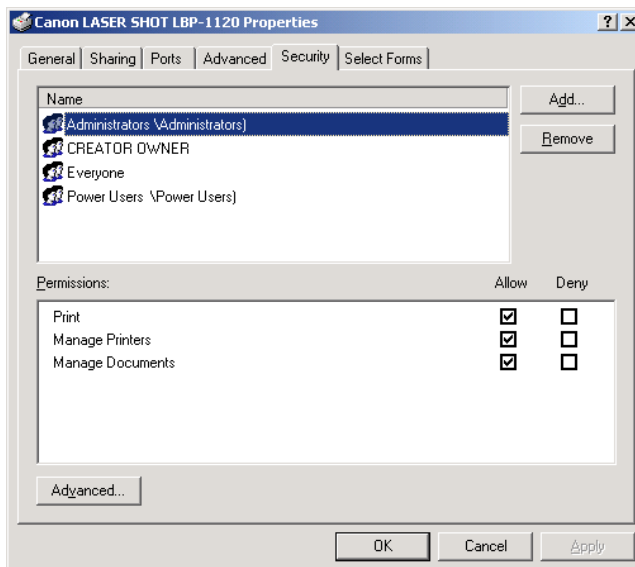

Select Forms Tab

This printer driver supports three custom paper sizes. Using the custom forms defined on the [Forms] tab in the print server's [Properties] dialog box, you can add information about the custom paper sizes. Form definitions must conform to the printer's specifications.

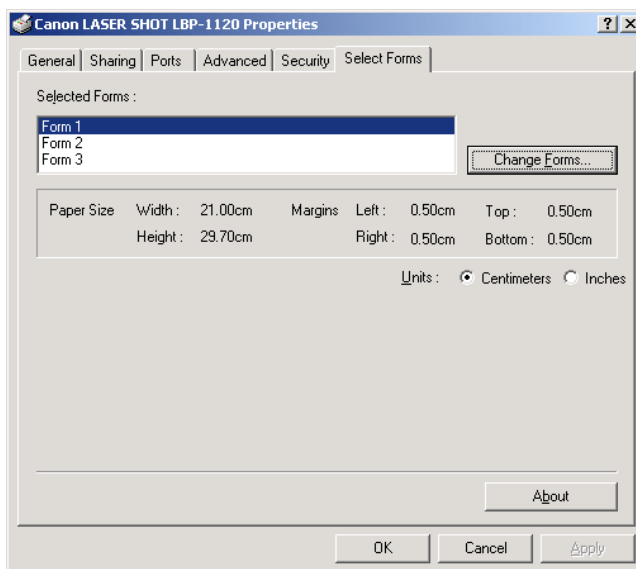

Selected Forms

Shows the three form names.

Change Forms

Opens the [Change Forms] dialog box. This dialog box contains a listing of the available forms, and their definitions (Available Forms have Height: 12.70 - 35.56 cm and Width: 7.62 - 21.59 cm) that were set in the [Forms] tab in the print server's Properties dialog box. Only forms that conform to the printer's specifications are listed as available. When you choose a form in the list and then click [OK], the form information is copied to the selected form in the [Selected Forms] list on the [Select Forms] sheet.

Page Setup Tab

Specifies the printer settings described below.

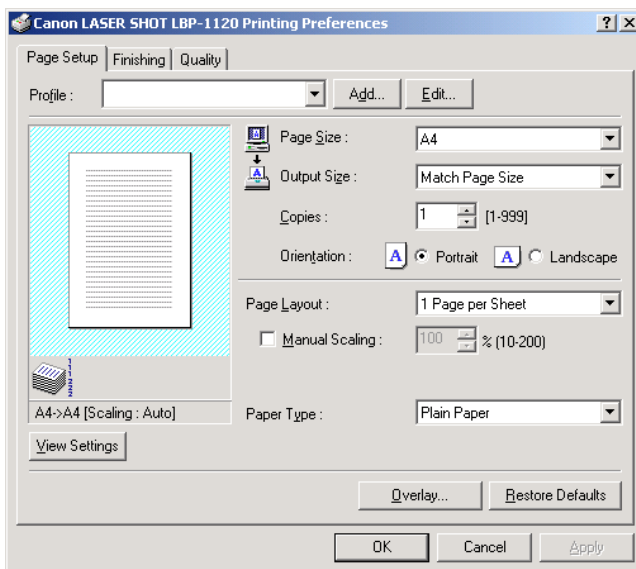

Profile

Lets you select the printer driver settings saved as profiles. (See "Using Profiles for Printing," on p. 3-77.)

Page Size

Lets you select the paper size you are working with in your application. (Letter, Legal, A4, B5, Executive, Envelope DL, Envelope #10, Envelope C5, Envelope Monarch, Index Card, and 3 custom paper sizes. The names for custom paper sizes can be defined by users.)

Output Size

Lets you select the paper size to print on.

NOTE

- Select [Match Page Size], if you want to print in the paper size you are working with in your application.
- If your output size is anything other than [Match Page Size], the image will be automatically reduced or enlarged to fit on the page.

Copies

Lets you specify the number of copies to be printed (1 - 999).

Orientation

Lets you select the direction of printing relative to the paper (Portrait, Landscape).

Page Layout

Lets you select the number of pages to print per sheet (1, 2, 4, 8, 9). When you select more than 1, the image may be reduced to fit on the selected output size. (See "Printing Multiple Pages on One Sheet," on p. 3-65.)

Manual Scaling/Page Order

Lets you shrink or enlarge images. This option only appears when [1 Page per Sheet] is selected as the page layout. (See "Scaling a Document," on p. 3-67.) When 2, 4, 8 or 9 per sheet is selected in [Page Layout], [Page Order] appears. You can specify the required page order for printing multiple pages.



Paper Type

Displays the [Paper Type] pull-down menu and lets you select the appropriate paper type to print on. The paper types you can select are as follows:

- Plain Paper: Transparencies, label sheets, and plain paper (64 - 90 g/m²)
- Heavy Paper: Plain paper (91 - 135 g/m²), and bond paper (90 g/m²)
- Heavy Paper High: Postcards, envelopes and custom paper with a width less than or equal to 182 mm

NOTE

If you are using a postcard, envelope, or custom size paper with a width less than 182 mm, the driver will print it as [Heavy Paper High], even when [Plain Paper] or [Heavy Paper] is specified.

View Settings

Displays the list of your current printer settings. (See "Viewing the Printer Settings," on p. 3-80.)

Overlay

Allows you to add data you use often, such as a logo, to the print data from an application. (See "Using the Overlay Printing," on p. 3-70.)

Finishing Tab

Specifies whether final output is collated. Check the [Collate] check box to collate the printouts.

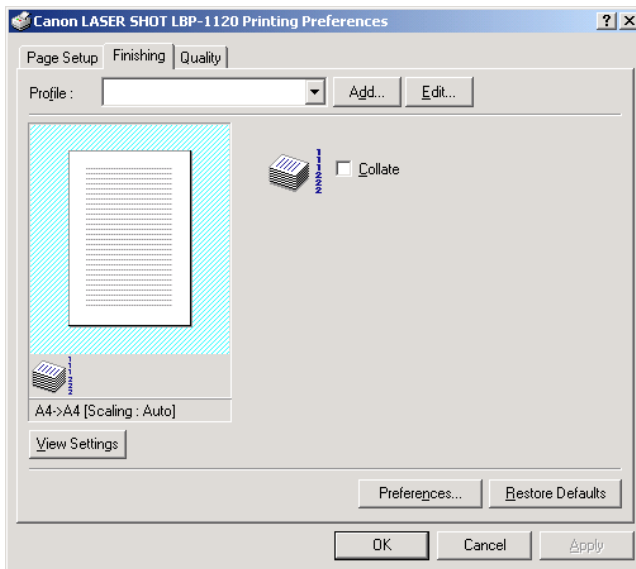

■ Preferences

[Preferences] on the [Finishing] sheet opens the [Preferences] dialog box shown below.

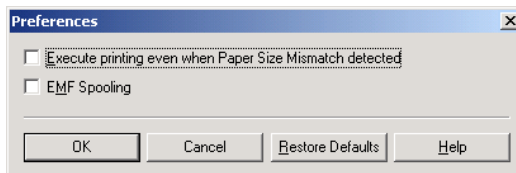

Execute printing even when Paper Size Mismatch detected

The check box lets you force pages to print, even when the paper size does not match. If this is not checked, you will be asked to change paper when a paper size mismatch is detected.

EMF Spooling

The check box sets the spool file format. If there is a check in the check box, it is spooled in metafile format. If there is no check in the check box, it is spooled in RAW format. If you have the printer set up as a network printer, it is set to spool in RAW format.

Quality Tab

Specifies the resolution, halftoning method, brightness, and contrast settings.

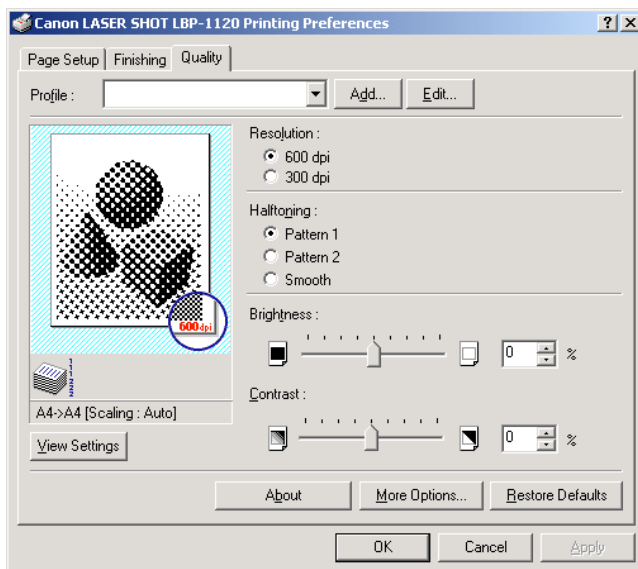

Resolution

Lets you specify the printer's resolution in dots per inch (600, 300). (See "Specifying the Print Quality," on p. 3-73.)

Halftoning

Lets you specify the halftoning methods (Pattern 1, Pattern 2, and Smooth). (See "Specifying the Print Quality," on p. 3-73.)

Brightness

Lets you specify the relative proportion of the light and dark areas of an image in the range from -80% to +80%. (See "Specifying the Print Quality," on p. 3-73.)

Contrast

Adjusts the degree of difference between the lightest and darkest areas of an image. (See "Specifying the Print Quality," on p. 3-73.)

More Options

Accesses the settings for [Toner Density], [Toner Saver], and [Automatic Image Refinement]. (See "Specifying the Toner Density," on p. 3-74 and "Using the Automatic Image Refinement," on p. 3-76.)

Printing Multiple Pages on One Sheet

Multiple pages can be printed on one sheet of paper. The number of document pages which can be printed on one sheet of paper is 2, 4, 8, or 9.

1 Display the [Page Setup] sheet.

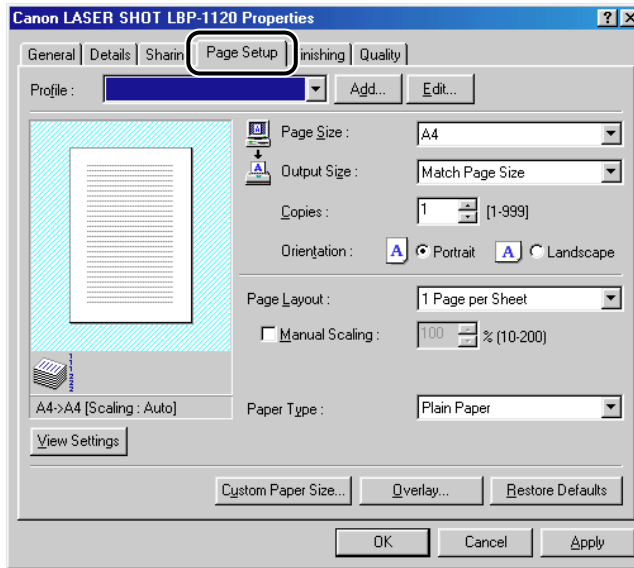

2 Select the required page layout from [Page Layout].

3 Select the required page order from [Page Order].

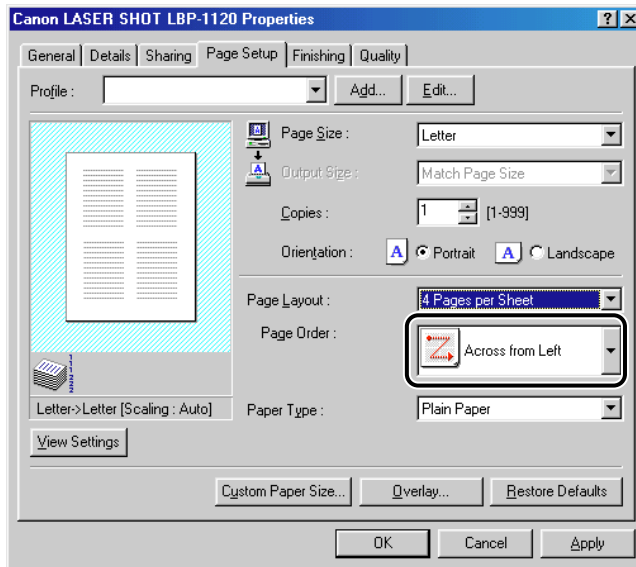

4 Click [OK].

3

Using the Canon Advanced Printing Technology

www.DataSheet4U.com

Scaling a Document

There are two methods for scaling a document: select the output size of the document to scale it automatically, or specify the scaling value manually.

Scaling a Document Automatically

1 Display the [Page Setup] sheet.

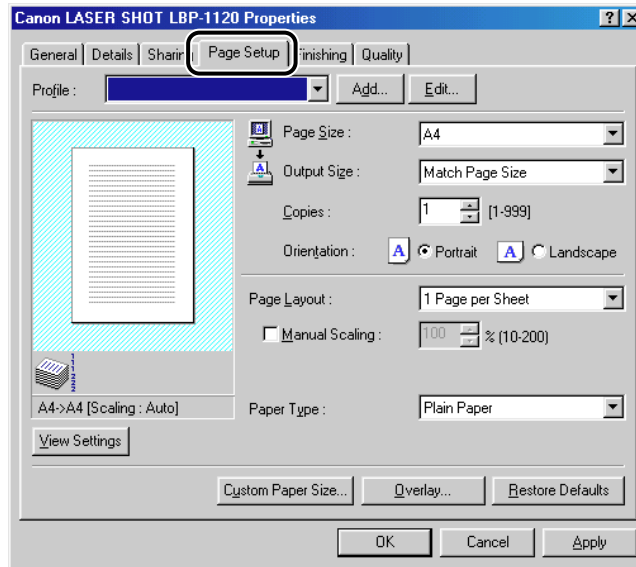

2 Select the page size from [Page Size].

If this driver setting is inaccessible from the application, click [Printer Settings] or [Page Settings] (depending on the application) on the [File] menu to specify the page size.

3 Select the actual paper size to print on from [Output Size].

4 Click [OK].

The scaling is set automatically according to the sizes specified in [Page Size] and [Output Size].

Scaling a Document Manually

1 Display the [Page Setup] sheet.

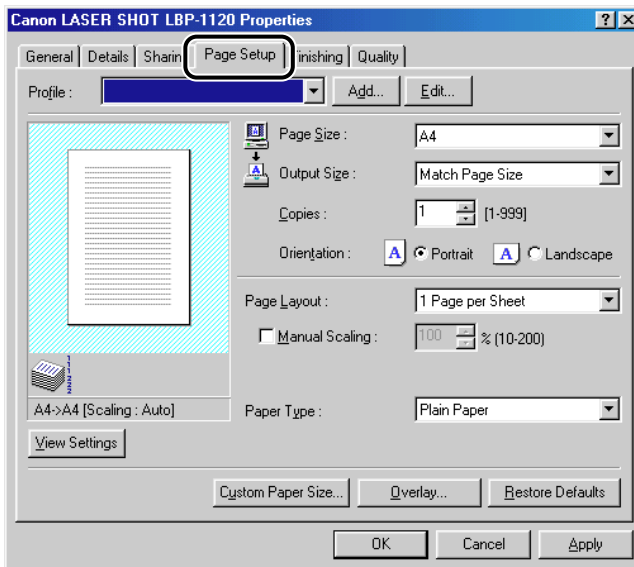

2 Select the page size from [Page Size].

If this driver setting is inaccessible from the application, click [Printer Settings] or [Page Settings] (depending on the application) on the [File] menu to specify the page size.

3 Select the actual paper size to print on from [Output Size].

4 Select [Manual Scaling], and then specify the desired scaling value from 10% to 200%.

5 Click [OK].

Selecting the Custom Paper Size Setting

To define the custom paper sizes, follow the procedure below.

- 1** Display the [Page Setup] sheet, and then click [Custom Paper Size].

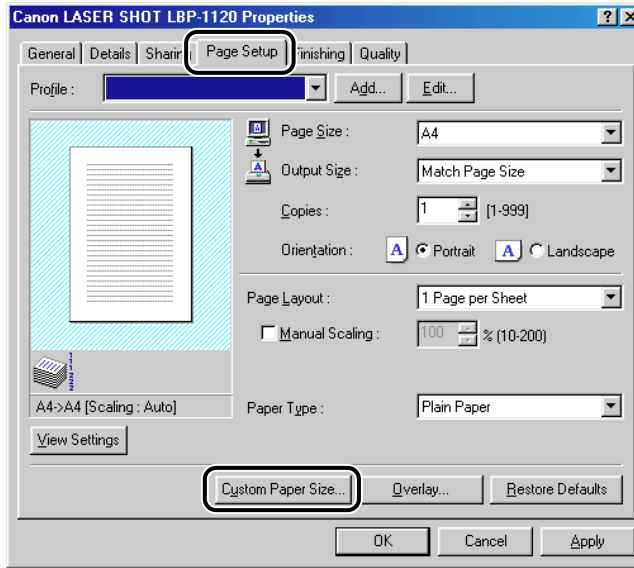

The [Custom Paper Size Setting] dialog box appears.

- 2** Select a paper size form from [Custom Paper List], and then specify the height and width of the paper to be used.

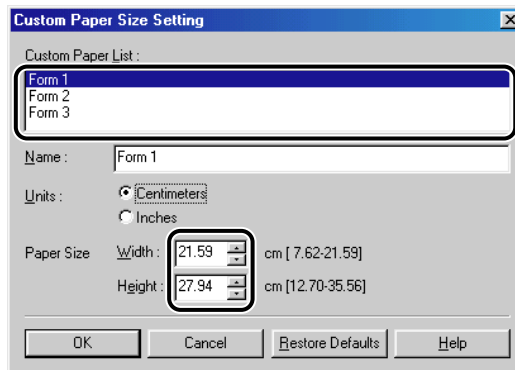

3 If you wish, enter a custom paper name in [Name].

[Form1], [Form 2], and [Form 3] have been set as default.

4 Click [OK].

The display returns to the [Page Setup] sheet. The name for the custom form you have defined is displayed in the list of [Page Size] and [Output Size].

Using the Overlay Printing

3

An overlay allows you to add data you use often, such as a logo, to the print data from an application. For example, when using an overlay you can automatically print your logo on letters you create. To perform overlay printing you must create a file in an application, and then register and store in your computer as form file for overlay printing.

You can use only the following two file types as form file for overlay printing.

- Windows metafile
- Windows bitmap



IMPORTANT

Form files created in LIPS format cannot be used.

■ Creating the Form File

Form files can be created with software bundled with Windows 98/Me/2000/XP, or other software sold separately.

- Windows Metafile
 - A file format that can be created using illustration software. Save images as Metafile (.wmf).
- Windows BMP
 - A file format that can be created using the software that handles image. It is easy to create file format. You can create BMP files using paint software bundled with Windows 98/Me/2000/XP, and other software sold separately, such as "Corel PhotoPaint." Save images as a BMP file (.bmp).

Printing with an Overlay

To perform overlay printing using a form file stored in your computer, follow the procedure below.

- 1** In the application, select [Print], and then click [Properties] in the [Print] dialog box.
- 2** Display the [Page Setup] sheet, and then click [Overlay].

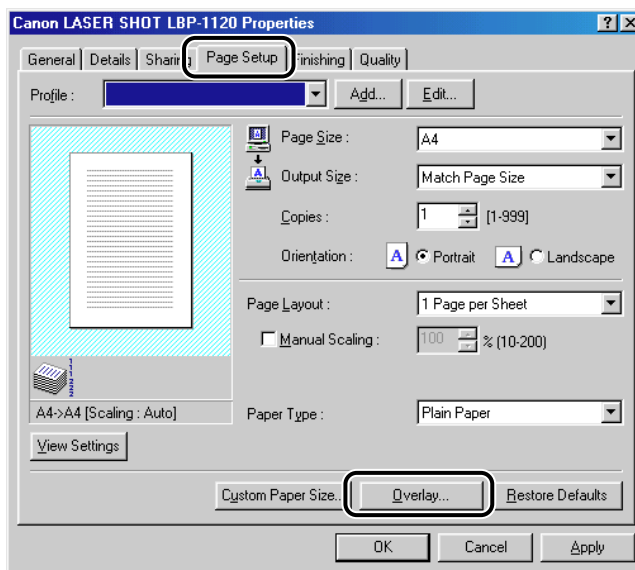

The [Overlay] dialog box appears

3 Click [Browse], and then select the name of a form file, and then click [OK].

The name of a form file is displayed in [File Name].

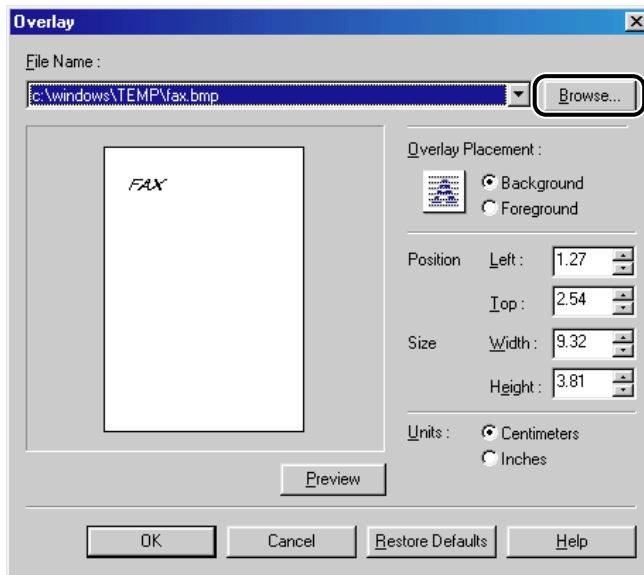

4 Specify the overlay settings as needed.

You can specify the following items for overlay printing.

Overlay Placement: Background

If you want the overlay to appear in back of the application data, check the [Background] check box.

Overlay Placement: Foreground

If you want the overlay to appear in front of the application data, check the [Foreground] check box.

Position: Left/Top

Specifies the position of the overlay based on its distance from paper's left and top edges (0 - 42 cm).

Size: Width/Height

Specifies the size of the overlay form (0 - 42 cm).

Units

Selects the units of measurement (centimeters or inches).

5 Click [OK] in the [Overlay] dialog box.

6 Click [OK] in the [Page Setup] sheet.

7 Click [OK] in the [Print] dialog box.

The document is printed with the selected form file overlaid.

Specifying the Print Quality

The [Quality] sheet enable you to specify print quality settings. Follow the procedure below to specify the print quality settings.

www.DataSheet4U.com

1 In the application, select [Print], and then click [Properties] in the [Print] dialog box.

2 Display the [Quality] sheet.

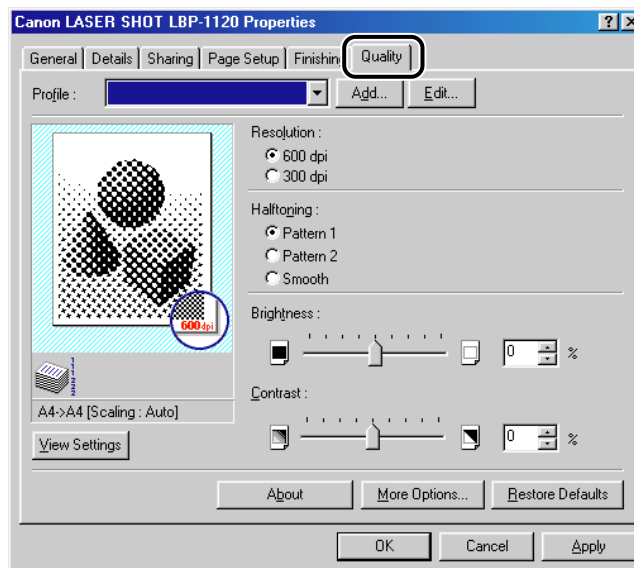

3 Specify the required resolution in [Resolution].

4 Specify the halftoning method that is suitable for the image you print in [Halftoning].

The halftoning methods you can specify are as follows:

Pattern 1 (Default)

Suitable for printing general document.

Pattern 2

Images with distinct outlines, such as letters and figures, are printed with a higher resolution.

Smooth

For printing at near-photographic quality.

5 Move the slide bar left and right to change the brightness and the contrast.

6 Make sure that all the settings have been specified and click [OK] in the [Quality] sheet.

7 Click [OK] in the [Print] dialog box.

The document is printed under the print quality settings you have specified.

Specifying the Toner Density

When printout is too dark or too light, you need to adjust the toner density. To specify the toner density setting according to your need, follow the procedure below.

1 In the application, select [Print], and then click [Properties] in the [Print] dialog box.

2 Display the [Quality] sheet, and then click [More Options].

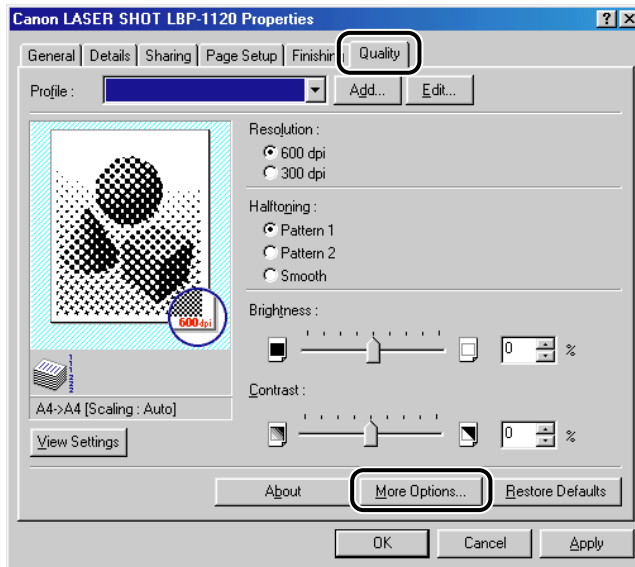

The [More Options] dialog box appears.

3 Move the slide bar left and right to change the toner density.

If you check the [Toner Save] check box, you can print only alternate data bits so that toner consumption is reduced.

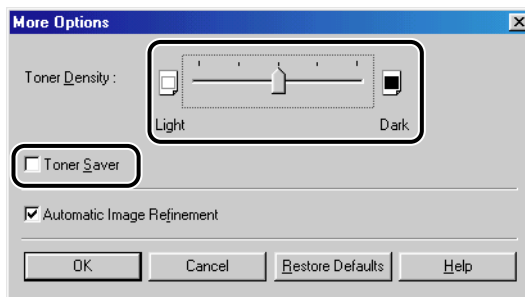

4 Click [OK] in the [More Options] dialog box.

5 Click [OK] in the [Quality] sheet.

6 Click [OK] in the [Print] dialog box.

The document is printed under the toner density setting you have specified.

Using the Automatic Image Refinement

3

Automatic Image Refinement is a printer technology from Canon, with which the printer automatically senses and refines the jagged edges and ragged curves of characters and graphics.

To use the Automatic Image Refinement, follow the procedure below.

1 Display the [Quality] sheet, and then click [More Options].

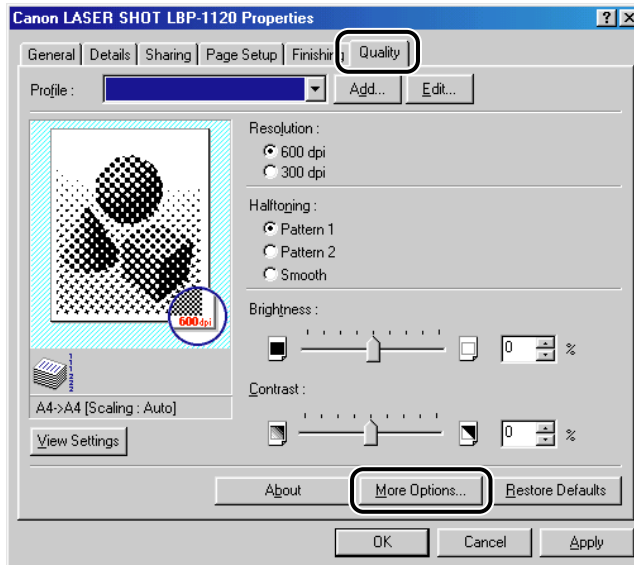

The [More Options] dialog box appears.

2 Check the [Automatic Image Refinement] check box.

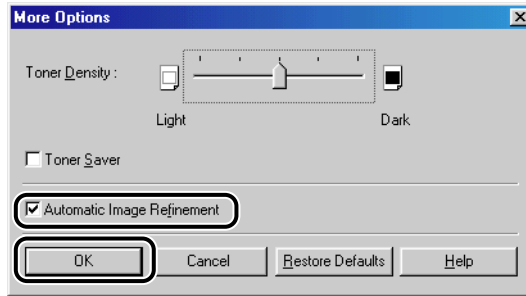

3 Click [OK] in the [More Options] dialog box.

4 Click [OK] in the [Quality] sheet.

The [Automatic Image Refinement] becomes available for printing.

Using Profiles for Printing

This section explains what a profile is, how to select a profile, and how to add or edit profiles.

What Is a Profile?

Various printer driver settings are saved as profiles. You can also save printer driver settings that you frequently use as profiles. When you select a profile, the document is printed under the saved settings. You can save up to 50 profiles.

Selecting a Profile for Printing

When you select a profile, the document is printed under the settings of the selected profile.

1 Display either the [Page Setup], [Finishing], or [Quality] sheet.

2 Select the profile you want from [Profile].

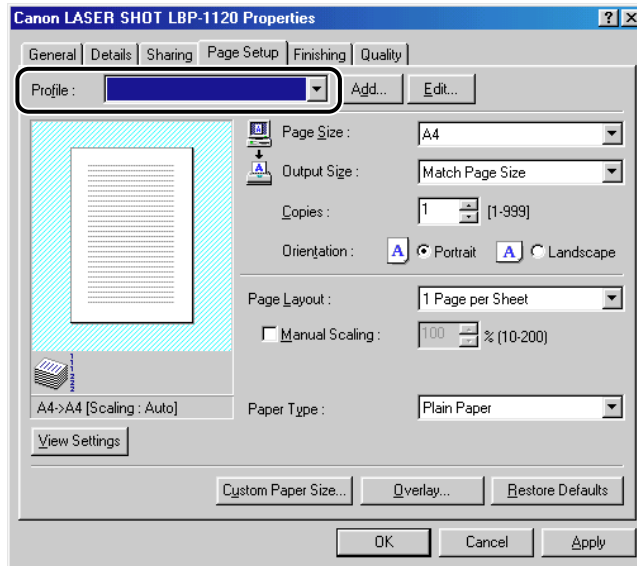

3 Click [OK].

3

Using the Canon Advanced Printing Technology

Adding or Editing Profiles

You can add your own profiles, or edit the name and icon of, or comment on the customized profiles. To add or edit profiles, follow the procedure below.

1 Specify the printer driver settings for the customized profile in the [Page Setup], [Finishing], and [Quality] sheets.

2 Click [Add] or [Edit] at the right of [Profile].

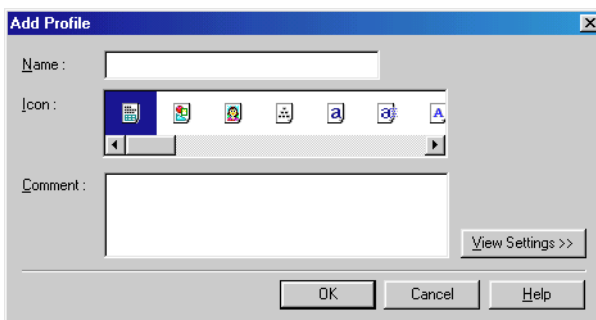

The [Add Profile] or [Edit Profile] dialog box opens.

3 Specify the name and icon of, and comment on the profile, and then click [OK].

For detailed information on adding or editing a profile, right-click the item of interest to display the pop-up help.



NOTE

- If you change the name assigned to your printer, you cannot retrieve any profiles saved for that printer. To retrieve the profiles, rename the printer to its original name.
- Profiles are not erased even when the printer driver is uninstalled.
- Overlay history information is not stored in profiles.
- The profiles saved in Windows 98/Me cannot be used in Windows 2000/XP.

Viewing the Printer Settings/Restoring the Default Settings

Viewing the Printer Settings

When you want to check the current printer settings, follow the procedure below.

1 Display either the [Page Setup], [Finishing], or [Quality] sheet.

2 Click [View Settings].

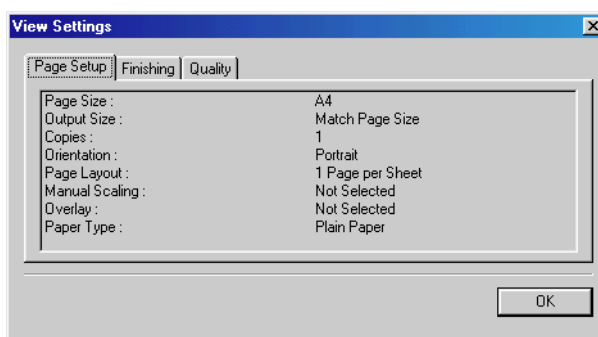

The [View Settings] dialog box appears.

Click the tabs in the [View Settings] dialog box to view the settings for each sheet.

3 Click [OK].

The display returns to either the [Page Setup], [Finishing], or [Quality] sheet.

You can check the print image on the preview window in each sheet.

Restoring the Default Settings

To restore the default settings, click [Restore Defaults], which is located on the [Page Setup], [Finishing], or [Quality] sheet.

Only the settings inside the displayed sheet will be returned to defaults when you click [Restore Defaults]. The [Page Setup], [Finishing] and [Quality] settings will not be restored to default settings all at once.

Checking the Status of a Print Job

You can track and control your print jobs using the Canon LASER SHOT LBP-1120 Status Window. The Status Window tells you the current printing job status and the printer's status by animations, sounds and icons.

Using the Status Window

The Status Window function is the same in both Windows 98/Me and Windows 2000/XP. The screens shown in the instructions below are from Windows 98.

For detailed information on the functions of the Status Window, see the online help.

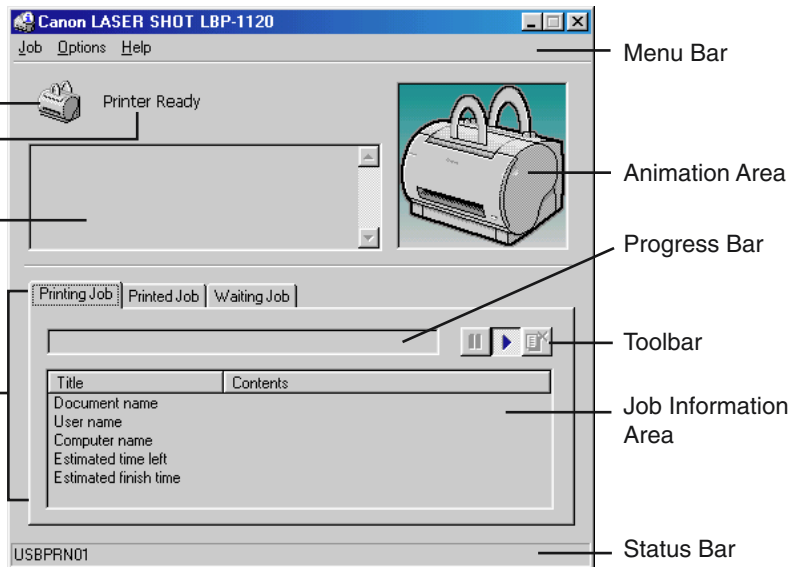

■ Using the Menu Bar

- Job Menu
 - Performs a print job operation (pause, resume, and delete). When the job status that you have no access right is displayed, these menus are grayed out.
- Options Menu
 - Changes the settings for the Status Window, and print the cleaning page.

- Help Menu
 - Displays the online help.

■ Other Functions

- Printer Icon
 - Displays the current printing status and error conditions.
- Printer Status Message Area
 - Displays the current status of the printer.
- Error Message Area
 - Gives a descriptions of situations requiring action.
- Animation Area
 - Shows an animated graphic indicating the current printer status. The graphic background changes from blue (normal) to orange when user action is required, or to red when a warning is issued.
- Tab Window
 - Displays print job information on [Printing Job], [Printed Job] and [Waiting Job] sheets by clicking each tab.
- Progress Bar
 - Indicates the progress of the current printing job.
- Toolbar
 - Performs a print job operation (pause, resume, and delete).
- Job Information Area
 - Displays information related to print jobs. The type of information displayed changes with the selected tab.
- Status Bar
 - Displays the name of the printer port and describes menu options as you move your mouse over them.

NOTE

If you want to hear the sound messages, you need to have a sound card and install the sound card driver.

Opening the Status Window

You can open the Status Window by clicking on the Status Window icon in the Windows taskbar and selecting [Canon LASER SHOT LBP-1120]. If multiple LBP-1120 printers are connected, select a printer from the list. The Status Window opens and displays information for the selected printer.

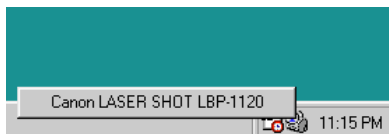

The Status Window opens automatically when you start printing and an error occurs during job processing. If [Displays Printer Status Window while printing] is not selected in the [Status Options] dialog box, the Status Window does not open when you start printing. (See "Status Options," on p. 3-84.)

www.DataSheet4U.com

Closing the Status Window

You can close the Status Window by right-clicking the Status Window icon in the Windows taskbar and selecting [Exits all printers' Printer Status Windows]. The Status Window is closed and the Status Window icon also disappears from the taskbar.

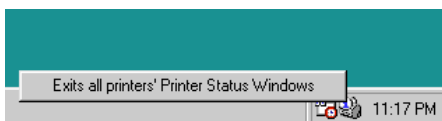

Status Options

This dialog box lets you define when and how you want the LBP-1120 Status Window to display. You can also set up sounds that play when there are errors.

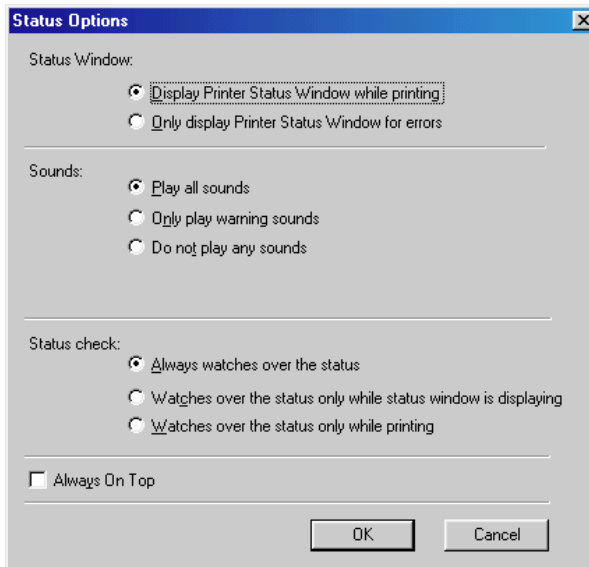

■ Status Window

- Display Printer Status Window while printing
 - The Status Window opens automatically each time you print.
- Only display Printer Status Window for errors
 - The Status Window opens only when an error occurs.

■ Sounds

- Play all sounds
 - A sound plays whenever there is printer activity.
- Only play warning sounds
 - A sound plays only when there is a printer error.
- Do not play any sounds
 - Sounds do not play.

■ Status check

- Always watches over status
 - The Status Window is continually monitoring the printer.
- Watches over the status only while status window is displaying
 - The Status Window is monitoring the printer status only while the Status Window is being displayed.
- Watches over the status only while printing
 - The Status Window is monitoring the printer only when printing a job.

■ Always On Top

Places the Status Window on top of all windows on the Desktop.

1 Select [Status Options] from the [Options] menu.



The [Status Options] dialog box appears.

2 After all the Status Window settings have been specified, click [OK].



NOTE

For detailed information on operations for the Status Window, see the online help.

Network Printer Status

The status of a network printer can be viewed on the print server as well as the client.

If you open the Status Window when the print server is not running, it will connect automatically when the print server is running.

- **Print Server Status**

- Displays the status of the local print job and the client print job.
- You can perform the print job operation on the [Printing Job] sheet and the [Waiting Job] sheet.
- Plays the sound messages.
- If the print server is Windows 2000/XP, the status is not displayed if no one is logged on.

- **Client's Status**

- You can perform the client print job operation on the [Printing Job] sheet.
- Clients cannot perform the print job operation on the [Waiting Job] sheet.
- Only users or computers with the same name as the client can play sound messages.

 **NOTE**

- Status display requires status exchanges between the print server and client using TCP/IP or NetBEUI protocols.
- Status display is not supported if IPX/SPX is the only protocol used.

Maintenance

4

CHAPTER

This chapter explains how to perform routine maintenance, such as replacing the toner cartridge and cleaning procedures.

Replacing the Toner Cartridge	4-2
Before Replacing the Toner Cartridge	4-3
Replacing the Toner Cartridge	4-6
Cleaning	4-10
Handling Toner Cartridges	4-11
Storing Toner Cartridges	4-13
Cleaning and Handling the Printer	4-14
Cleaning the Printer	4-14
Handling the Printer	4-16

Replacing the Toner Cartridge

Toner cartridges are consumable products. When a cartridge is almost out of toner, printed text becomes faded or streaked with white. When you find such a print quality problem, try the following procedure. Then replace the toner cartridge with a new one.

When you replace the toner cartridges, be sure to use the right one for this printer: a Canon EP-22 cartridge.

WARNING

The fixing assembly inside the printer gets extremely hot. Be careful not to touch any of the parts inside the cover except those specified in this manual. Doing so may result in personal injury, or burns.

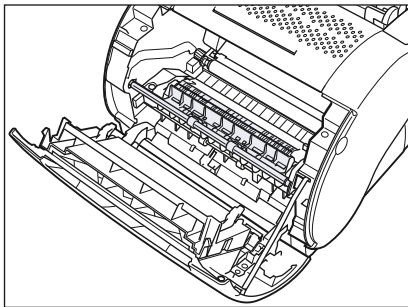

IMPORTANT

Never touch the high-voltage contact points inside the front cover. This could damage the printer.

NOTE

- The EP-22 cartridge typically lasts for about 2,500 prints of Letter or A4-size paper. This assumes that the printer is used for standard word processing documents printed at the default density, and at 4% dot ratio (equivalent to print coverage of approximately 5%).
- The life of your cartridge may vary depending on how it is used. If your average document contains a lot of graphics, shading or bold printing, or when you print on A5-size paper or smaller, then the life of the toner cartridge is shorter.

Before Replacing the Toner Cartridge

You can use the following simple procedure to extend the life of the toner cartridge:

WARNING

If you get loose toner powder on your hands or clothing, wash it off with cold water immediately.

NOTE

If the printed text is still streaked or faded, it is time to replace the toner cartridge. Follow the procedure in the next section to replace the toner cartridge.

- 1** Grasp the top of the front cover on both sides, then gently pull the cover until it is fully open.

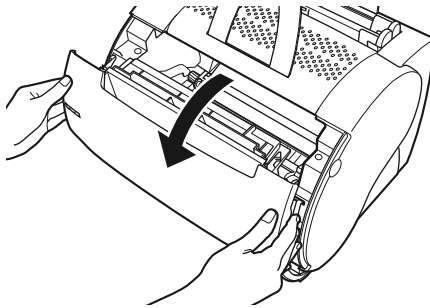

- 2** Grasp the cartridge by its handle and lift it out of the printer.

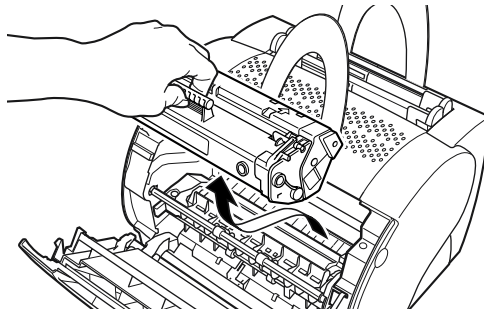

IMPORTANT

- Be sure to handle the toner cartridge correctly. Never stand the toner cartridge on its end or turn it upside down.

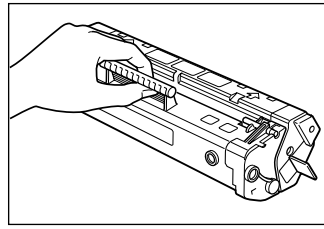
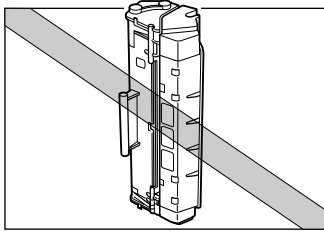

- Do not open the drum's protective shutter on the cartridge.

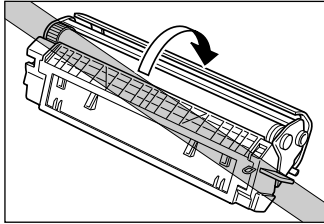

- Do not touch the drum's protective shutter. Avoid holding the cartridge in such a way that your hand is touching the drum's protective shutter.

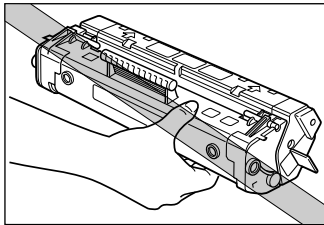

3 Hold the cartridge, then gently rock it from side to side five or six times to distribute the toner evenly inside the cartridge.

Rock the toner cartridge gently, taking care not to spill the toner.

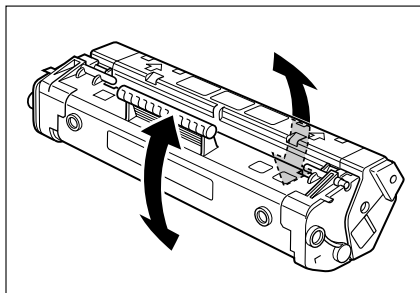

IMPORTANT

If the toner is not evenly distributed inside the cartridge, it can cause streaking or fading on the printed page.

4 Insert the toner cartridge back into the printer.

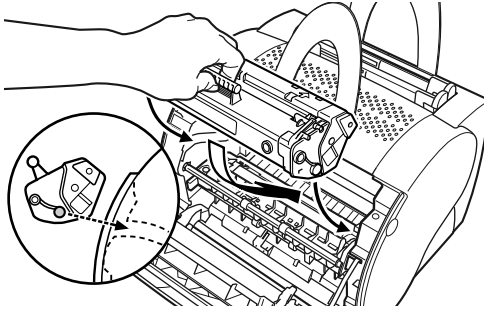

5 Close the front cover immediately after inserting a cartridge.

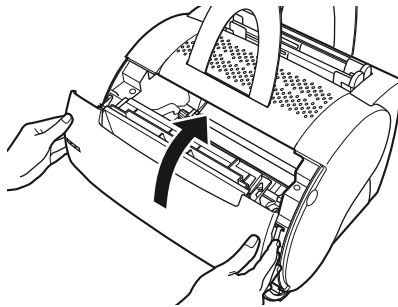

IMPORTANT

- If the toner cartridge is not correctly installed, the front cover cannot be closed completely. Do not try to force the front cover shut, as this may damage it. If you cannot close the front cover completely, open it and check the installation of the toner cartridge.
- Do not leave the front cover open for a long time after installing the toner cartridge.

Replacing the Toner Cartridge

Follow the instructions below to replace the toner cartridge.

WARNING

To avoid a fire or personal injury, never attempt to incinerate a used toner cartridge. Toner residue inside the cartridge is flammable.

CAUTION

- If you get loose toner powder on your hands or clothing, wash it off with cold water immediately.
- Do not put your hand inside the front cover immediately after the printer has been used as the fixing assembly inside the printer gets extremely hot. Be careful not to touch any of the parts inside the cover except those specified in this manual. Doing so may result in personal injury or burns.

- 1** Grasp the top of the front cover on both sides, then gently pull the cover until it is fully open.

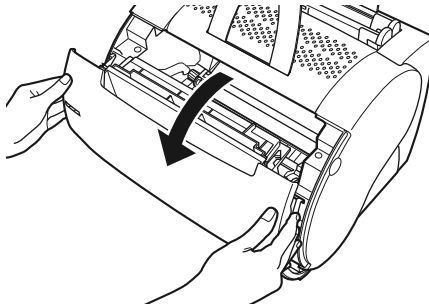

- 2** Grasp the cartridge by its handle and lift it out of the printer.

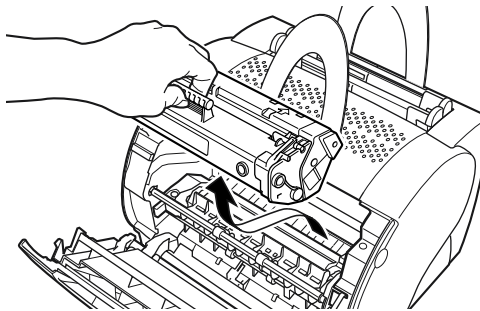

3 Remove the new toner cartridge from its protective bag.

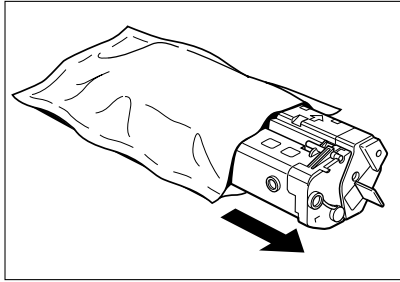

IMPORTANT

- Before you install the cartridge, ensure it has adjusted to room temperature especially if the toner cartridge has been moved from a cold to a warm location. If a cold cartridge is installed in the printer, condensation may form inside the cartridge and cause a reduction in print quality.
- Before you install the cartridge, check the expiration date printed on the box. Old toner cartridges can cause poor print quality. Always use a cartridge before its expiration date.
- Save the protective bag. You may need it later if you have to remove the toner cartridge from the printer.

4 Hold the cartridge, then gently rock it from side to side five or six times to distribute the toner evenly inside the cartridge.

Rock the toner cartridge gently, taking care not to spill the toner.

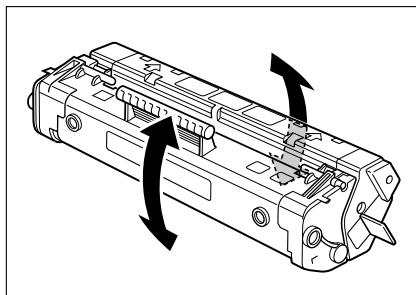

IMPORTANT

If the toner is not evenly distributed inside the cartridge, it can cause streaking or fading on the printed page.

- 5** Place the cartridge on a sturdy surface. Snap the tab at the end of the cartridge backwards and fold it back and forth until it is loose.

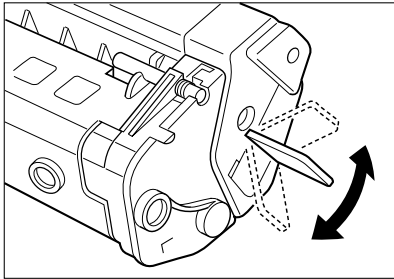

- 6** While holding the cartridge firmly with one hand, pull the sealing tape in the direction indicated in the illustration below.

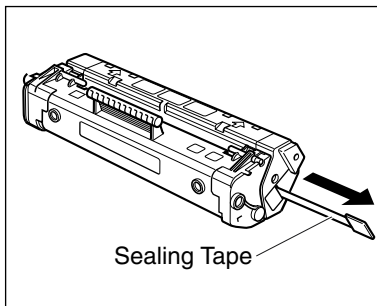

Pull in this direction

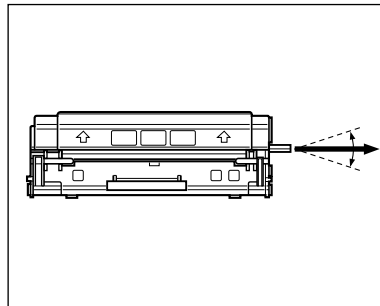

Pull within this angle

IMPORTANT

- To avoid breaking the tape, do not pull the tape out at an upwards or downwards angle.
- If the tab breaks off the tape, pull the tape out by pulling on the end of the tape where the tab was originally attached.
- Do not stop pulling out the sealing tape. If you stop pulling it, loose toner can scatter, causing a reduction in print quality.
- Dispose of the sealing tape properly.
- If you get loose toner powder on your hands or clothing, wash it off with cold water immediately.

- 7** Insert the cartridge into the printer along the guides. Make sure that the cartridge slides all the way inside the printer.

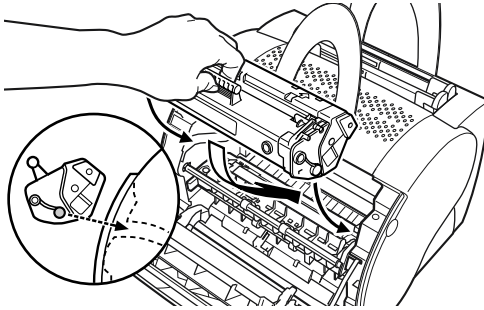

- 8** Close the front cover immediately after inserting a cartridge.

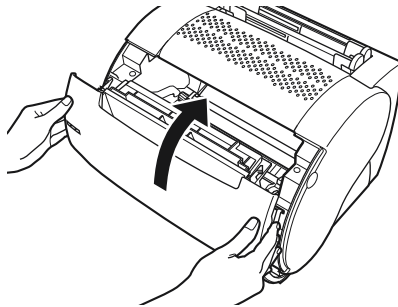

 **IMPORTANT**

- If the toner cartridge is not correctly installed, the front cover cannot close completely. Do not try to force the cover shut, as this may damage it. If you cannot close the front cover completely, open it and check the installation of the toner cartridge.
- Do not leave the front cover open for a long time after installing the toner cartridge.

Replacement of the toner cartridge is complete. After you install a new toner cartridge, you must clean the printer by using the cleaning function of the CAPT. Refer to the procedure in the next section to use the cleaning function.



Recycling Toner Cartridges

Canon supports the collection of used toner cartridges for recycling. Toner cartridge recycling cannot succeed without your help. We would like to encourage you to support the Canon Cartridge Recycling Program and bring your used cartridge to the CANON distributor from where you have purchased the cartridge, or to your nearest CANON dealer.

Cleaning

When you replace the toner cartridge, or printing quality is poor, you need to use the cleaning function of the CAPT. Follow the procedure below to use the cleaning function.

- 1** Place Letter or A4-size paper in the multi-purpose tray.
- 2** Click on the Status Window icon in the Windows taskbar to open the Status Window.
- 3** Select [Cleaning] from the [Options] menu.

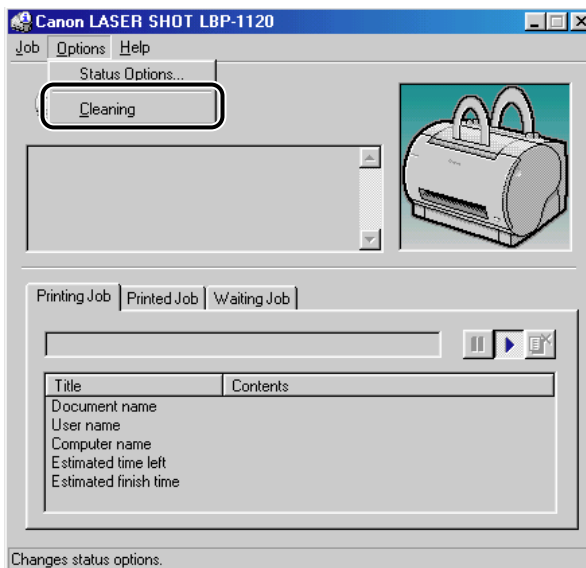

A cleaning sheet starts printing.

When printing starts, the Status Windows message area displays [Cleaning] and when printing completes, it returns to normal.



www.DataSheet4U.com

 **IMPORTANT**

While cleaning is in progress, you cannot pause the printing or changing paper setting.

Handling Toner Cartridges

Toner cartridges consist of light-sensitive parts and precision parts. Rough handling of the toner cartridge can cause the cartridge to break or reduce the print quality.

Follow the precautions in this section when installing or removing the toner cartridge:

 **WARNING**

To avoid a fire or personal injury, never attempt to incinerate a used toner cartridge. Toner residue inside the cartridge is flammable.

 **IMPORTANT**

- If you get loose toner powder on your hands or clothing, wash it off with cold water immediately.
- Be sure to handle the toner cartridge correctly. Never stand the toner cartridge on end, or turn it upside down.

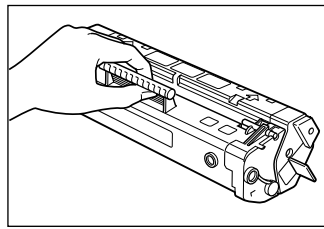
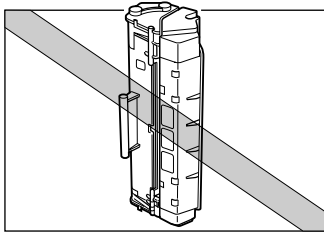

- Do not open the drum's protective shutter on the cartridge.

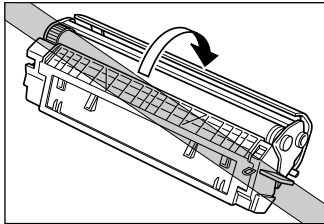

- Do not touch the drum's protective shutter. Avoid holding the cartridge in such a way that your hand is touching the drum's protective shutter.

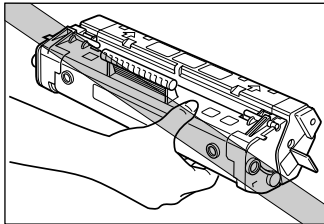

- Do not leave or place the cartridge where it is exposed to direct sunlight.
- Keep the toner cartridge away from your computer screen, disk drives, and floppy disks—the magnets in the toner cartridge can erase valuable data.
- Never attempt to disassemble a toner cartridge.
- Condensation may form on a toner cartridge if it is subjected to extreme changes in temperature and/or humidity, adversely affecting print quality. If you move the cartridge to a location that is warmer or has higher humidity, let it sit out of the box for about an hour. This allows it to slowly adjust to the new temperature, preventing condensation from forming.
- Before you install the cartridge, check the expiration date printed on the box. Old toner cartridges can cause poor print quality. Always use a cartridge before its expiration date.
- Never store the toner cartridge in salty air or where there are corrosive gases (e.g. from aerosol sprays).

Storing Toner Cartridges

Follow the instructions below to store replacement toner cartridges or cartridges removed from the printer for repair, or cartridges that have been taken out of the printer for moving purposes.



IMPORTANT

- Store the toner cartridge in its protective bag. Do not open the bag until you are ready to install the new toner cartridge in the printer.
- When you remove the toner cartridge from the printer, store it in its original protective bag, or wrap a sheet of paper around the cartridge to prevent dust from accumulating on the drum. Then wrap the cartridge in a piece of thick cloth.
- Always store toner cartridges laying flat. Never stand the cartridge on end or turn it upside down.
- Do not store the cartridge where it is exposed to direct sunlight.
- Never store a toner cartridge in areas with high temperatures or humidity, or where the temperature or humidity can change suddenly.
- The applicable temperature range for storage: 0° - 35°C (32° - 95°F).
- The applicable humidity range for storage: 35% - 85% RH (relative humidity), with no condensation.
- Never store the toner cartridge in salty air, or where there are corrosive gases (e.g. from aerosol sprays).
- Store the toner cartridge in a clean, dry location.
- Keep the toner cartridge away from devices that emit a magnetic field, such as the display or main unit of your computer.
- Keep the toner cartridge away from your computer screen, disk drives, and floppy disks—the magnets in the toner cartridge can erase valuable data.
- Keep the toner cartridge out of the reach of children.

Preventing Condensation

Condensation may form in a toner cartridge if it is subject to extreme changes in temperature and/or humidity, which can adversely affect print quality. If you move the cartridge to a location that is warmer or has higher humidity, let it sit out of the box for about an hour. This allows it to slowly adjust to the new temperature, preventing condensation from forming.

Cleaning and Handling the Printer

This section describes how to care for and maintain your printer. Regular care and maintenance helps keep your printer in good working order.

Cleaning the Printer

Follow the instructions below to regularly clean the printer, so it remains in top operating condition, and continues to deliver high quality performance.

4

Maintenance

CAUTION

- Turn OFF the power switch and disconnect the power cord to clean the printer. Not doing so may cause a fire or electrical shock.
- Never use flammable solvent such as alcohol, benzene, and paint thinner for cleaning. If a flammable solvent adheres to electrical parts inside the printer, it may result in a fire or electrical shock.

IMPORTANT

- Never use any cleaning solvent other than water or a water-diluted neutral detergent to prevent deterioration or cracks in the plastic parts of the printer.
- Be sure to dilute neutral detergent with water.
- Never attempt to lubricate the front cover, or mechanism inside the printer. The printer does not require lubrication.

- 1** Turn the power switch to OFF ("O" side) → disconnect the power cord from the AC outlet.

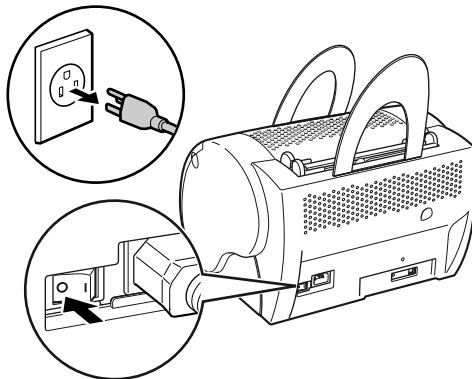

- 2** Moisten a soft cloth with water, or water-diluted neutral detergent. Squeeze the water or detergent out of the cloth → wipe the printer with the cloth to remove stains.

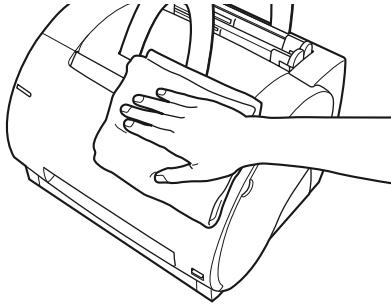

If you use a neutral detergent for cleaning, wipe off the neutral detergent remaining on the printer with a soft cloth, moistened with water.

- 3** After removing stains, wipe the printer with a soft, dry cloth to remove the remaining moisture.
- 4** Connect the power cord to the AC outlet after the body surface has dried completely.

Handling the Printer

Follow the precautions in this section when handling the printer:



IMPORTANT

- Do not place any heavy objects on the printer.
- Do not insert paper or other objects into the face-down delivery slot.
- When the printer is printing, do not rock or move the printer, and do not open the front cover. If you do, the printer might be damaged.
- Do not subject the multi-purpose tray and the manual feed slot area to direct sunlight or other strong light.
- After unplugging it from the AC outlet, wait until the printer has cooled off completely before covering it with a dust cover.
- If you are not going to use the printer for an extended period of time, unplug it from the AC outlet.
- Never attempt to disassemble the printer.

Troubleshooting

5

CHAPTER

This chapter describes printing problems that can be solved by following a few simple procedures. Do not attempt to solve problems other than those described in this chapter. If you cannot solve a problem, call your local authorized Canon dealer.

When You Have Trouble Printing	5-2
Problems and Solutions Without Messages	5-4
Print Quality Problems	5-4
Printer Problems	5-5
CAPT Problems	5-7
Clearing Paper Jams	5-9
Before Removing Paper Jams Inside the Printer	5-12
Paper Jam in the Paper Feed Area	5-13
Paper Jams Near the Imaging Area	5-15
Paper Jam in the Face-Down Delivery Area	5-17
Paper Jam in the Face-Up Delivery Area	5-18
Using the Trouble Shooter	5-19
Features of the Trouble Shooter	5-19
Starting the Trouble Shooter	5-19
Responding to Error Messages	5-21

When You Have Trouble Printing

If your printer is unable to print or you have problems with the printer or print quality, use this map to find the appropriate page for help.

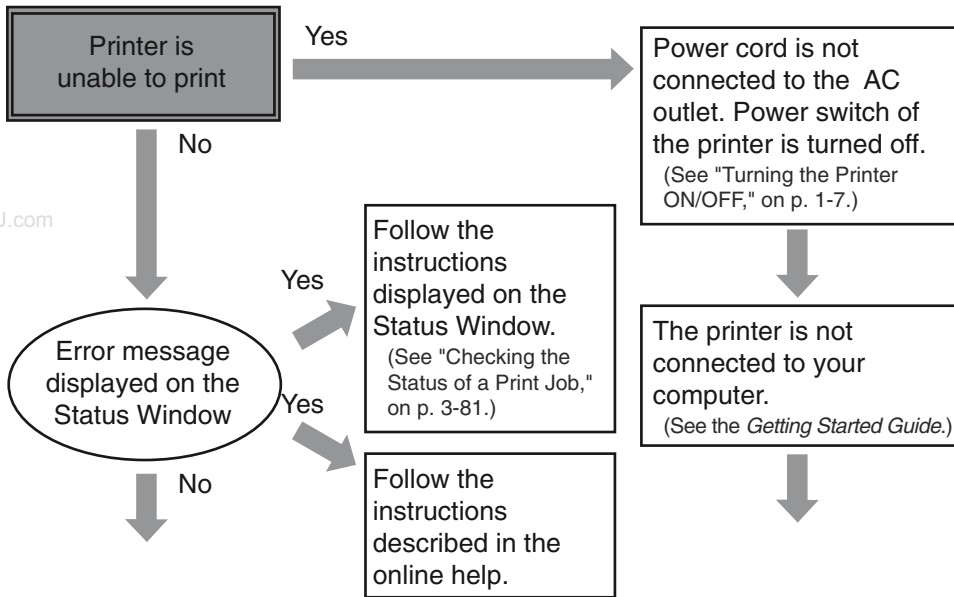

www.DataSheet4U.com

5

Troubleshooting

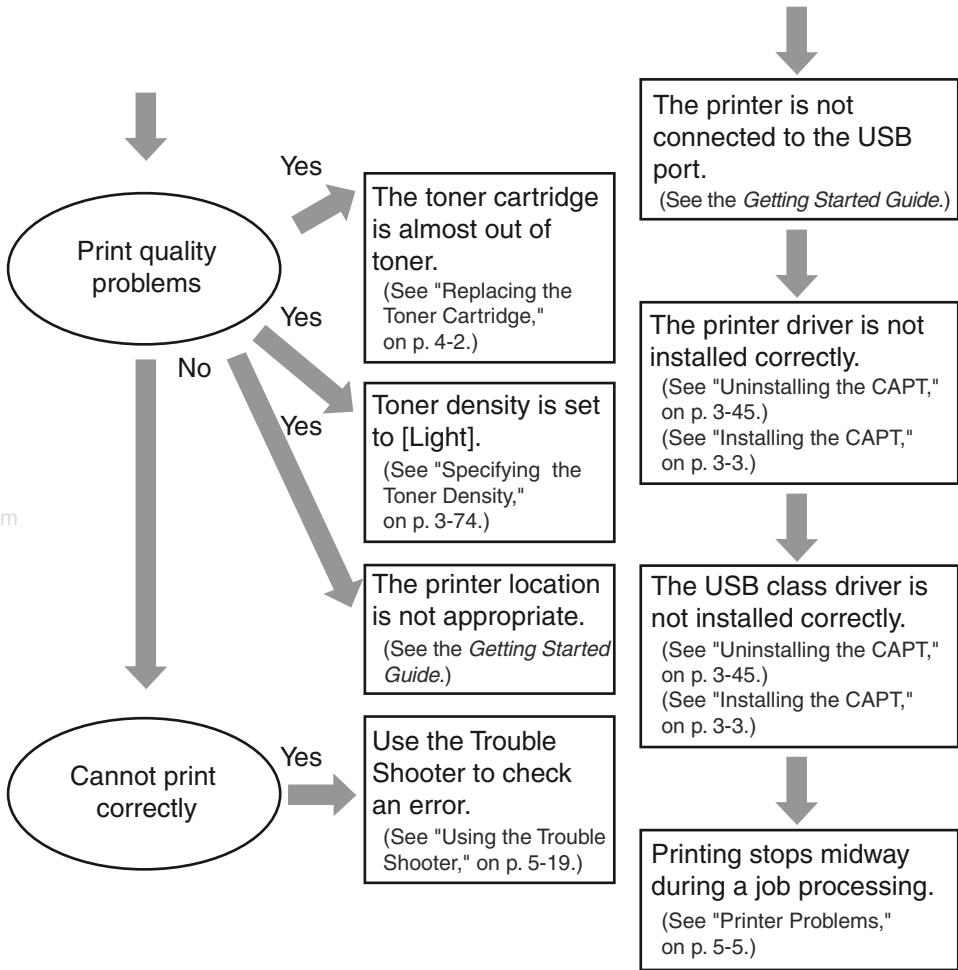

Problems and Solutions Without Messages

Use the following procedures to solve problems that do not cause the Status Window to display a message.



IMPORTANT

- Refer to "Responding to Error Messages," on p. 5-21 when messages are displayed.
- If symptoms not specified in this section occur, a problem persists even after following these procedures, or the cause cannot be figured out at all, contact your local authorized Canon dealer.

Print Quality Problems

5

Troubleshooting

Printout has vertical white streaks.

Cause Toner is low or unevenly distributed inside the cartridge.

Remedy Remove the toner cartridge from the printer. Rock the cartridge gently from side to side five or six times to evenly distribute the toner inside, and then insert it back into the printer. If the problem persists, replace the toner cartridge with a new one. (See "Replacing the Toner Cartridge," on p. 4-6.)

Printout has black specks.

Cause Toner powder adheres to the pressure roller.

Remedy Use the cleaning function of the CAPT to clean the pressure roller. (See "Cleaning," on p. 4-10.) If there are no black specks on the cleaning page, the pressure roller is clean. If there are black specks on the cleaning page, repeat cleaning until there are no black specks on it. You can repeat cleaning several times with no adverse effect on the printer.

Printout is too light.

Cause 1 [Toner Density] is set to [Light].

Remedy Increase the toner density. (See "Specifying the Toner Density," on p. 3-74.)

Cause 2 The printer is used for high volume printing in a hot environment.

Remedy Adjust the toner density. If there is no effect, replace the toner cartridge with a new one. (See "Replacing the Toner Cartridge," on p. 4-6.) After you replace the cartridge, use the printer in a cooler environment.

Printout is too dark.

Cause 1 [Toner Density] is set to [Dark].

Remedy Make sure that the density adjustment is correct. If not, adjust the density. (See "Specifying the Toner Density," on p. 3-74)

Cause 2 There is a strong light source near the printer.

Remedy Make sure that there is no strong light source near the printer. If there is, move the printer or the light source.

Printer Problems

Printer does not print.

Cause 1 Paper may not be loaded.

Remedy Make sure that paper is loaded.

Cause 2 Print jobs may be stalled.

Remedy Check the Status Window for stalled jobs.

Cause 3 The toner cartridge may not be installed correctly.

Remedy Make sure that the cartridge is installed correctly. See the *Getting Started Guide*.

Cause 4 Your BIOS port setting needs to be modified.

Remedy Refer to your computer's documentation concerning available ports.

Cause 5 Your computer may not be working properly.

Remedy Check your computer, make sure that it is turned on and working properly.

Cause 6 Your software may be sending the wrong codes.

Remedy Check the software you are using. It may have sent a stop code or similar command to the printer. Make sure that the correct printer is selected in the [Printers] folder.

No power is supplied.

Cause 1 Power cord may not be plugged in.

Remedy Make sure that the power cord is securely plugged in to both the printer and the AC outlet.

Cause 2 AC outlet may not be supplying power.

Remedy Make sure that the AC outlet is supplying power; try another outlet if necessary.

Cause 3 AC voltage may not match the printer.

Remedy Make sure that the voltage of the AC outlet matches the ratings on the printer.

Printer stops printing.

Cause 1 Your interface cable may be loose.

Remedy Check your computer and your cable.

Cause 2 You may be working on an application in the foreground, in which case printing performance may slow down.

Remedy Printer performance improves if you give your print job priority.

Printout is wrong.

Cause There may be a communications problem between the printer and your computer.

Remedy Make sure that your cable connections are secure. Make sure that you are not using a switch box. Check that you have selected the correct printer driver in Windows.

Printer locks up system.

Cause There may be a problem with your system setup.

Remedy 1 Make sure that you have a high-quality shielded interface cable.

Remedy 2 There may be a problem with your BIOS. Verify that your BIOS setup is correct. For detailed information, see your computer's documentation.

Remedy 3 Make sure that your physical memory is working correctly.

Remedy 4 If you have a Toshiba laptop, change this line in your CONFIG.SYS file:
c:\winutils\mxttime.exe to: REM c:\winutils\mxttime.exe.

Computer indicates a device time-out.

Cause 1 Your computer is sending data to the printer but the printer is not responding. The printer may be turned off, offline, or not connected to the computer.

Remedy 1 Make sure that the printer is not paused.

Remedy 2 Make sure that the printer's interface cable is securely connected to both the printer and the computer.

Remedy 3 Reset the printer and computer, then try printing again.

Cause 2 Paper may not be loaded in the paper tray correctly.

Remedy Make sure that paper is properly loaded in the paper tray.

Cause 3 There may be a problem with your interface cable.

Remedy Try a different cable.

CAPT Problems

CAPT is not working properly.

Cause 1 The CAPT for LBP-1120 is not selected as the default printer driver.

Remedy Specify the CAPT for the LBP-1120 as the default driver.

Cause 2 The software may not be installed properly.

Remedy 1 Launch the Trouble Shooter to detect a problems. See "Using the Trouble Shooter," on p. 5-19.

Remedy 2 To make sure that the CAPT is installed correctly, try printing a page from an application. If the print fails, the CAPT is not installed correctly. Remove the CAPT and install it again. See "Uninstalling the CAPT," on p. 3-45, and "Installing the CAPT," on p. 3-3.

Adobe Type Manager (ATM) font cannot be used.

Cause You may be using the wrong version of Adobe Type Manager.

Remedy Use Adobe Type Manager ver. 2.51 or later.

CD-ROM Menu does not appear automatically.

Cause 1 [Autorun CD-ROM Menu] is unchecked in the CD-ROM menu.

Remedy Start CD-ROM menu manually, and check the [Autorun CD-ROM Menu] check box.

Cause 2 [Auto insert notification] is unchecked.

Remedy From [Device Manager] make sure that [Auto insert notification] is checked in the CD-ROM drive properties dialog box. For detailed information, refer to Windows Help.

[File not found on CD-ROM] error occurs when starting the CD-ROM menu.

Cause The program is loaded from the hard disk drive.

Remedy Remove the CAP3MNU.EXE file from your hard disk drive and restart the CD-ROM Menu program from the compact disk labeled "User Software."

Clearing Paper Jams

When a paper jam occurs during printing due to some reason, the Status Window automatically opens and displays the error message <PAPER JAM>. When a paper jam occurs, remove the jammed paper in the printer following the steps of procedure described below and resume printing. If the message remains after removing the jammed paper according to the prescribed procedure, broken pieces of the jammed paper may still remain in the printer. In this case, check various sections of the printer again to remove all pieces of the paper from inside the printer.

Paper jams can occur in several locations along the print path. Refer to the diagram below to help you locate paper jams. Locate the area where the paper jam has occurred and follow the instructions for removing jams in that area. Be sure to check all areas before resuming printing.

- ① Paper feed area (See "Paper Jam in the Paper Feed Area," on p. 5-13.)
- ② Image area (See "Paper Jams Near the Imaging Area," on p. 5-15.)
- ③ Face-down delivery area (See "Paper Jam in the Face-Down Delivery Area," on p. 5-17.)
- ④ Face-up delivery area (See "Paper Jam in the Face-Up Delivery Area," on p. 5-18.)

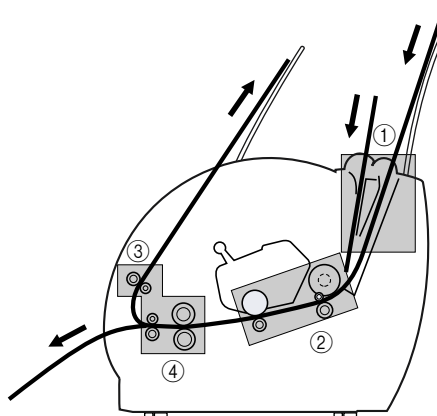

After you replace the cartridge and close the front cover, the printer should be ready for printing. If the printer returns to the ready state for printing, troubleshooting has been successful. If the printer does not return to the ready state for printing, paper may still be jammed in the printer.

⚠ CAUTION

- Remove watches and any bracelets or rings when touching the inside of the printer. These items may be damaged if they come into contact with parts inside the printer.
- The fixing assembly inside the printer gets extremely hot. Be careful not to touch any of the parts inside the cover except those specified in this manual. Doing so may result in a personal injury or burns.

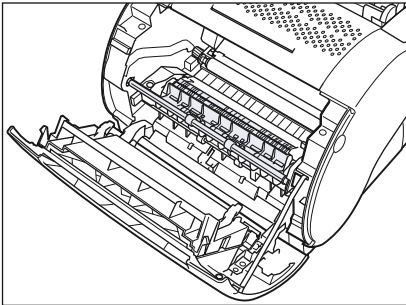

- Never touch the high-voltage contact points inside the front cover. This could damage the printer.

🚫 IMPORTANT

- Be careful when handling the paper behind the fixing assembly. The toner is not fixed to the paper and can easily dislodge.
- If you get loose toner powder on your hands or clothing, wash it off with cold water immediately.
- To avoid possible damage to the printer, do not touch the pins near the right end of the transfer roller.

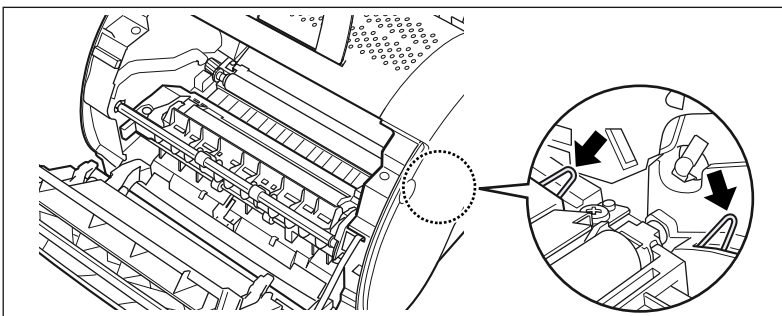

- Remove the jammed paper with the power to the printer still on. If you turn the power off, the data being printing will be erased.

- When you have opened the front cover, take care not to touch the transfer roller located inside the cover.

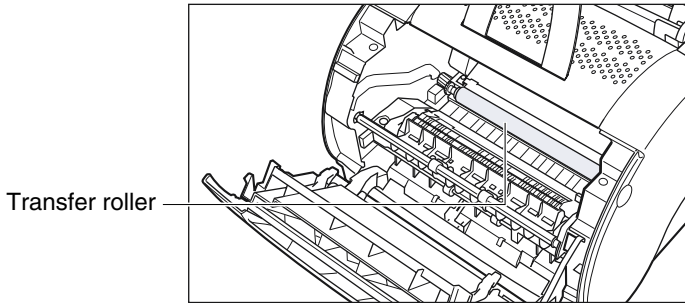

- If you attempt to remove the jammed paper forcibly, the paper may be torn or the inside device may be damaged. Pull out the jammed paper in the correct direction according to the location at which the paper is jammed.
- When the jammed paper has torn, find the scrap pieces of the paper remaining inside the printer and remove them.
- To avoid damaging the printer, check that the pressure release levers (black) were released when the front cover was opened. If the pressure release levers were not released, close the front cover and then open it again. This should automatically release the pressure release levers. If the levers were not released automatically, release them manually by pulling the levers at either end of the pressure bar slightly forwards with your fingers, so they release the bar.

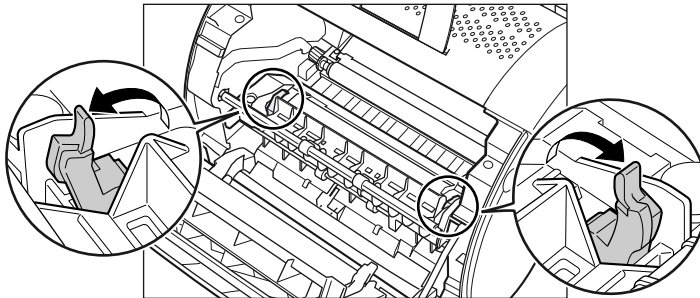

 NOTE

While removing the jammed paper, some toner may stain the inside of the printer which will make the first few printouts dirty when printing resumes.

Before Removing Paper Jams Inside the Printer

When a paper jam occurs, follow the procedure below before removing the jammed paper from the affected area.

1 Remove the paper from the multi-purpose tray.

2 Open the front cover with both hands until it stops.

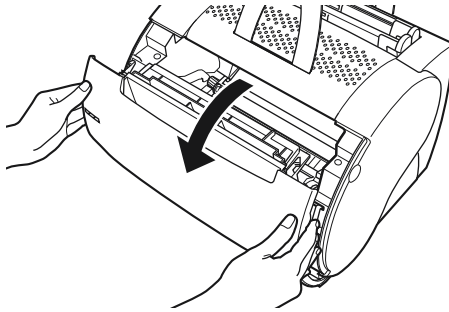

3 Remove the cartridge by grasping the cartridge's handle and lifting it out of the printer.

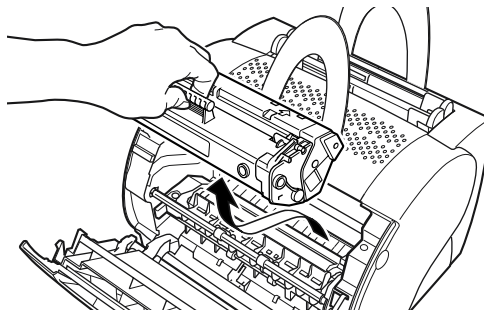

IMPORTANT

Do not expose the cartridge to light for more than 5 minutes. If necessary, put the cartridge in its original protective bag or wrap it with a thick cloth to prevent exposure to light.

Paper Jam in the Paper Feed Area

■ *If only a small portion of the paper has moved into the printer*

- 1** Use both hands to carefully pull the jammed paper straight up and out from the multi-purpose tray.

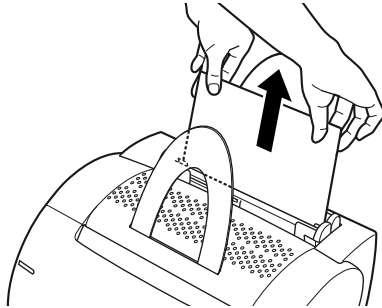

IMPORTANT

- Use both hands to remove jammed paper from the printer.
- Be careful not to tear the paper when pulling. If the paper is torn, remove the paper scraps from the printer.

■ *If the paper has moved completely into the printer*

- 1** Remove the toner cartridge from the printer. (See "Before Removing Paper Jams Inside the Printer," on p. 5-12.)
- 2** Remove any paper from the input area by gently pulling it forward.

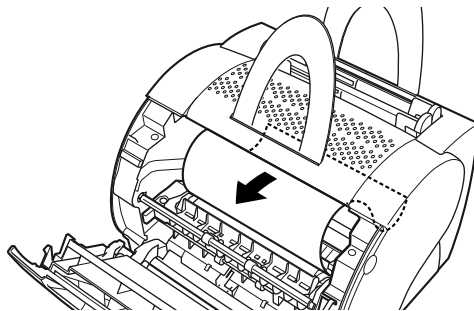

IMPORTANT

Use both hands to remove jammed paper from the printer.

- 3** Roll the edge of the paper inwards so that the printed surface is on the inside of the roll.

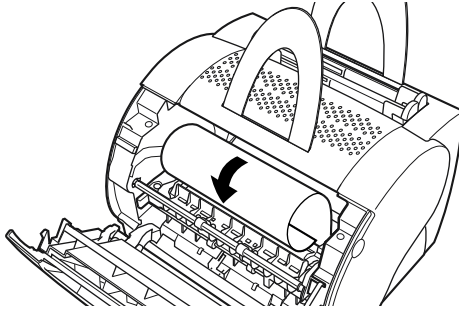

- 4** Gently pull the rolled up paper out of the printer.

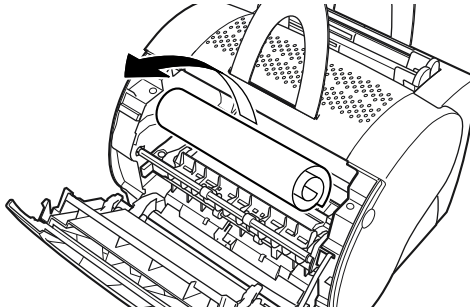

If the leading edge of the paper is visible but has not entered the imaging area, pull the paper forwards and roll it inwards.

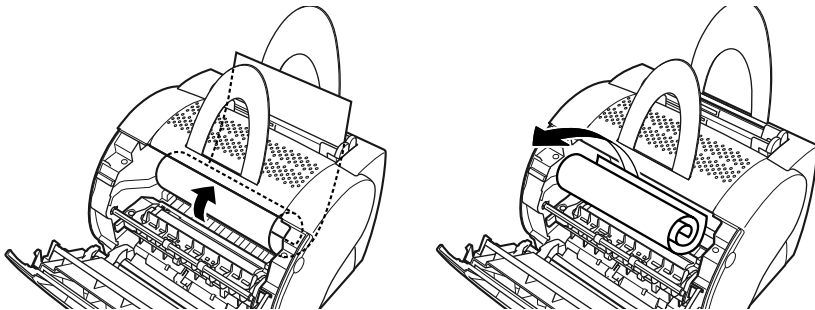

Do not pull the paper upwards from the paper input slot, as this may damage the printer. Gently pull the paper out of the printer.

IMPORTANT

Do not remove jammed paper at a sharp upwards angle. The toner on the paper will stain the printer and cause a permanent reduction in print quality.

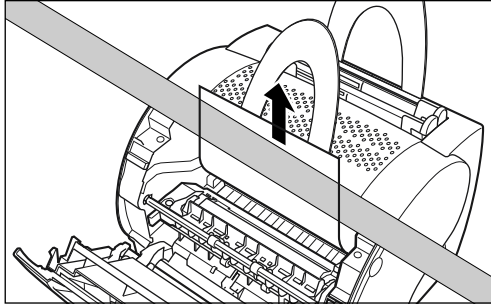

5 Replace the cartridge and close the front cover.

The paper release levers automatically return to their original positions.

Paper Jams Near the Imaging Area

1 Remove the toner cartridge from the printer. (See "Before Removing Paper Jams Inside the Printer," on p. 5-12.)

2 Roll the paper inwards from the rear edge, so that the printed surface is on the inside of the roll and the paper is pulled back out from the imaging area.

If you cannot see the rear edge of the paper, hold both sides of the paper, and gently pull the paper until you can see the edge of the paper.

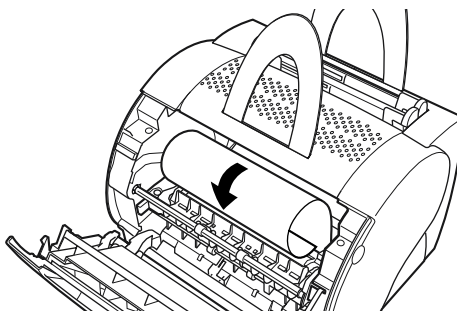

IMPORTANT

Use both hands to remove jammed paper from the printer.

3 Gently pull the rolled paper out of the printer.

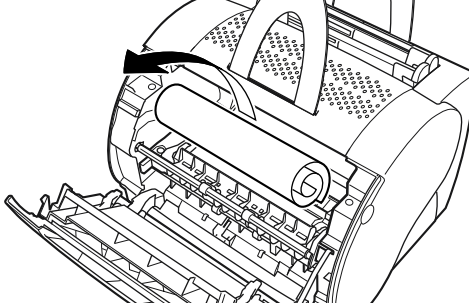

4 Replace the cartridge and close the front cover.

The paper release levers automatically return to their original positions.

www.DataSheet4U.com

5

Troubleshooting

Paper Jam in the Face-Down Delivery Area

- 1** Remove the toner cartridge from the printer. (See "Before Removing Paper Jams Inside the Printer," on p. 5-12.)
- 2** Gently pull the jammed paper between the face-down delivery rollers until the leading edge emerges from the printer.

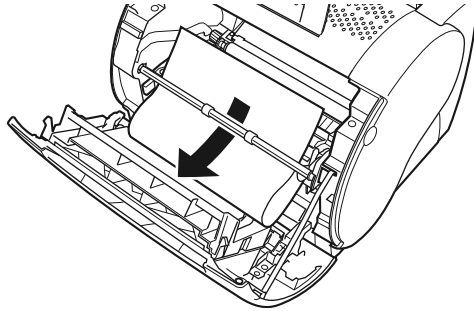

www.DataSheet4U.com



IMPORTANT

Use both hands to remove jammed paper from the printer.

- 3** Carefully pull the jammed paper through the rollers and out of the printer.



IMPORTANT

Never pull the paper out of the printer by pulling it forwards if the paper is behind the face-down delivery rollers. This could result in damage to the face-down delivery rollers.

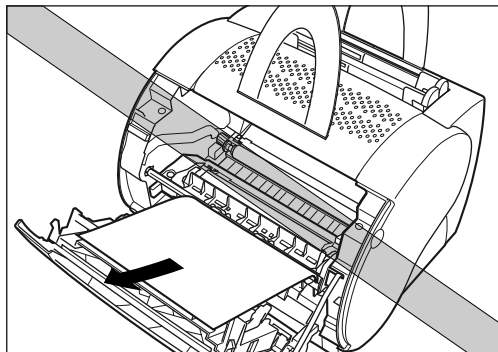

4 Replace the cartridge and close the front cover.

The paper release levers automatically return to their original positions.

Paper Jam in the Face-Up Delivery Area

1 Remove the toner cartridge from the printer. ("Before Removing Paper Jams Inside the Printer," on p. 5-12.)

2 While holding the printer steady, carefully pull the jammed paper out as illustrated below.

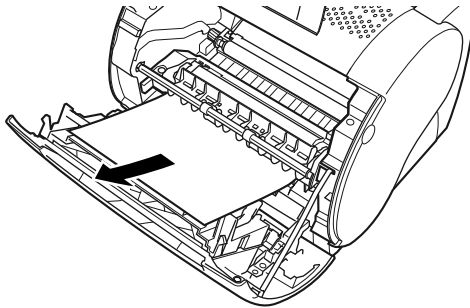

IMPORTANT

Use both hands to remove jammed paper from the printer.

If the jammed paper is badly folded, similar to the folds of an accordion, ease the jammed paper loose and then pull it out of the printer.

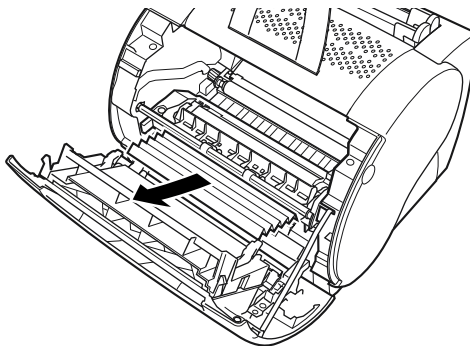

3 Replace the cartridge and close the front cover.

The paper release levers automatically return to their original positions.

Using the Trouble Shooter

The Trouble Shooter is a utility for solving printing problems in Windows 98/Me or 2000/XP. This section describes the features of the Trouble Shooter and how to use it.

Features of the Trouble Shooter

The Trouble Shooter checks for system configuration setting errors, and if possible, makes automatic corrections. However the Trouble Shooter does not detect problems related to hardware, such as printer cable problems or USB port failure.

The Trouble Shooter checks the following and corrects any problems:

- Selected printer port (The Trouble Shooter checks to see if usable.)
- Installed files
- Free disk space in the drive containing the \Windows directory and free memory
- Registries
- Printer Properties settings
- Language monitor
- Printer Driver
- Status Window
- Canon LASER SHOT LBP-1120 program folder
- Network (If the Trouble Shooter is used on a network, it performs network-related checks.)

Starting the Trouble Shooter

- 1** Click [Start] → point to [Programs].
- 2** Point to [Canon LASER SHOT LBP-1120] → click [Canon LASER SHOT LBP-1120 Trouble Shooter].

The [Trouble Shooter] dialog box appears.

The Trouble Shooter can be launched by double-clicking [Canon LASER SHOT LBP-1120 Trouble Shooter] in the [Canon LASER SHOT LBP-1120] group folder on the Desktop.

3 Select the printer that troubleshooting will be carried out for → click [Yes].

The Trouble Shooter checks your file.

4 If a problem is found, messages are displayed on the screen. Follow the instructions on the screen to solve the problem.

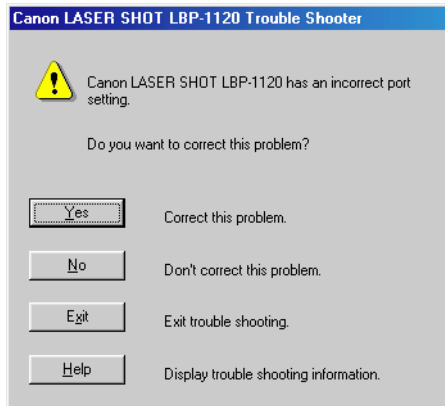

5 When the Trouble Shooter is done checking your files, a dialog box as shown below appears. Click [OK].

The [Windows Restart] dialog box appears.

If a problem is not found, the display returns to Windows.



NOTE

Check the [Save Result] check box, if you want to save the results as a text file.

6 Click [Windows Restart].

You must restart Windows for corrections made by the Trouble Shooter to take effect.

Troubleshooting is complete.

Responding to Error Messages

If printing is disabled during a print job for some reason, the Status Window will open and display an error message. Error messages identify problems that must be corrected before printing can continue. When any of these messages appear on the Status Window, follow one of the remedies listed to respond to the message.

Add Paper

Cause The printer is out of paper.

Remedy Add paper to the tray. When you add paper, the Status Window displays <Printer Ready> automatically.

Change paper to...

Cause The paper in the printer and the specified paper are not the same size.

Remedy Replace the paper so that it matches the specified paper size, or use the [Resume Job] menu option in the Status Window to start printing on the paper in the printer.

Check Printer/Cable

Cause Your computer and printer are not communicating. The printer power shuts off, or the cable is disconnected.

Remedy Connect the printer cable or power cord securely.

Check Toner Cartridge

Cause There is not toner cartridge in the printer.

Remedy Install the toner cartridge. For detailed information, see the *Getting Started Guide*.

Clear Paper Jam

Cause 1 Paper is jammed in the printer while printing.

Remedy Clear the paper jam. Printing starts automatically when the paper jam is cleared. See "Clearing Paper Jams," on p. 5-9.

Cause 2 The front cover was left open or the toner cartridge was not properly replaced after clearing a paper jam.

Remedy Close the front cover securely.

Close Printer Cover

Cause The front cover is open.

Remedy Close the front cover to resume printing.

Insufficient Memory

Cause The print job was too complex for available memory.

Remedy 1 Close other applications while printing this job.

Remedy 2 Print the job in smaller sections.

Remedy 3 Try reprinting the job with a lower resolution, such as 300 dpi.

Remedy 4 Reformat the most complicated pages in the print job to reduce graphics and other complex formatting.

Port Busy

Cause The printer port is being used by other equipment.

Remedy Wait a while until the printer port being used becomes available.

Printing Failed

Cause The print job was too complex for available memory.

Remedy 1 Try reprinting the job with a lower resolution, such as 300 dpi.

Remedy 2 Reformat the most complicated pages in the print job to reduce graphics and other complex formatting.

Remedy 3 Try reprinting only the page on which the error has occurred.

Service Error

Cause The Canon Advanced Printing Technology has detected an internal problem in the LBP-1120 engine.

Remedy Follow the procedure described below to solve the problem:

1. Turn off and unplug the printer.
2. Open the front cover and remove the toner cartridge.
3. Plug in and turn on your printer.
4. If the error persists, contact your authorized Canon representative.

Appendix

6

CHAPTER

This chapter summarizes and contains the index and glossary for this manual, and the specifications of the printer.

Specifications	6-2
Glossary	6-4
Index	6-14

Specifications

Specifications are subject to change without notice for product improvement or future release.

■ Hardware Specification

Type	Desktop page printer
Printing Process	Electrophotographic printing using laser beam scanning
Printing Speed	10 pages per minute (A4-size paper)
Warm-up Time	0 second (Less than 8 seconds when the printer is turned on)
First Print Output Time	Face-down delivery: Less than 18 seconds* Face-up delivery: Less than 17 seconds* *Note: printing on A4-size paper using the multi-purpose tray at 20°C (68°F)
Paper Sizes	Multi-purpose tray Plain paper (Legal, A4, Letter, Executive, B5) Maximum capacity: approximately 125 sheets of 64 g/m ² Special paper (transparency films, labels, envelopes, postcards, index cards, colored paper) Maximum capacity: 12.5 mm stack height (except for envelopes) Envelope capacity: 6 to 10 envelopes Manual feed slot Plain paper (Legal, A4, Letter, Executive, B5), Special paper (transparency films, labels, envelopes, postcards, index cards, colored paper) Maximum capacity: 1 sheet
Paper Delivery Method	Face-down Face-up
Paper Delivery Tray Capacity	Face-down delivery tray: approximately 50 sheets of 64 g/m ² plain paper

Noise Level	<p>Sound Power Level During printing: Max. 6.2 Bels* During standby: Background noise level</p> <p>Sound Pressure Level (Bystander positions) During printing: Max. 53 dB (A)* During standby: Background noise level</p> <p>*Note: Declared noise emissions in accordance with ISO 9296.</p>
Environmental requirements for operation	<p>Operating temperature: 10 to 32.5°C (50 to 90.5°F) Humidity: 20 to 80% RH (no condensation)</p>
Environmental requirements for storage	<p>Storage temperature: 0 to 35°C (32 to 95°F) Humidity: 10 to 80% RH (no condensation)</p>
Power Source	<p>100 - 127 V (±10%) 50/60 Hz (±2 Hz) 220 - 240 V (-10%, +6%) 50 Hz (± 2Hz)</p>
Power Consumption (20°C or 68°F)	<p>100 - 127 V During printing: approximately 250 W (Average) During standby: approximately 5 W</p> <p>220 - 240 V During printing: approximately 250 W (Average) During standby: approximately 5 W</p>
Mass	<p>Printer body: Approximately 6.0 kg (13.2 lb.) EP-22 cartridge: Approximately 730 g (1-5/81 lb.)</p>

■ Software Specifications

Printing Software	CAPT (Canon Advanced Printing Technology)
Printable Area	Data cannot be printed inside a 5 mm wide border around the paper. (Data cannot be printed inside a 10 mm wide border around the envelopes.)

Glossary

A

AC

Alternating Current. The type of electrical current typically available from household wall outlets.

Alert

A message displayed in the Printer Status Window when a problem or condition caused the Canon Advanced Printing Technology to pause printing. You must follow the on-screen instructions before printing resumes.

Attributes

The characteristics of a font. These include symbol set, orientation, pitch, point size, spacing, weight, and height. See also Font.

Audio messages

Audio messages notify the user of the printer operations shown in the Status Window.

Automatic Image Refinement

A printer technology from Canon, with which the printer automatically senses and refines the jagged edges and ragged curves of characters and graphics.

B

Bi-directional communications

Allows information to pass back and forth between the Canon Advanced Printing Technology software and a local printer.

Bold

A characteristic of a printed character that indicates wider, darker representation. Also referred to as emphasized or double-strike printing.

Brightness

The relative proportion of light and dark areas. Decreasing brightness darkens the overall image; increasing brightness lightens it.

C

Canon Advanced Printing Technology (CAPT)

Software that extends the power of the Windows operating system to a printer to speed up and simplify printing. The Canon Advanced Printing Technology provides more printing control and bi-directional communication between the printer and a computer running a Windows application.

Client

A computer that is connected to the printer over a network. A client does not control the printer directly. It interacts with the printer through a server. See also Server.

Collate

To print multiple copies of a multi-page document in sequential page order.

Command

An instruction that tells the printer to perform a certain function. Commands are sent from the computer to the printer via the interface cable when the printer is ready.

Contrast

The degree of difference between the lightest and darkest areas of an image. Decreasing contrast lightens the dark areas and darkens the light areas; increasing it darkens the dark areas and lightens the light areas.

Control Panels

The set of Windows programs you can use to change system, hardware, software, and Windows settings.

D

Default setting

A setting that is automatically used if no other setting is specified.

Desktop

The entire Windows screen that represents your work area in Windows. Icons, windows, and the taskbar are displayed on the Windows Desktop.

dpi

Dots per inch. A unit of measurement for indicating a printer's resolution. The LBP-1120 prints at a resolution of 600 dpi.

Driver

A program that controls how the computer and an external device interact. The printer driver supplies Windows with information such as descriptions of the fonts and features of the installed printer. When you print with the Canon Advanced Printing Technology, you are using its printer driver.

F

Fixing assembly

The device used during the print process to fix the toner onto the paper (or other media) through applying heat and pressure. The assembly, located inside the printer, gets extremely hot (374°F/190°C) during operation.

Folder

A container in which documents, program files, and other folders are stored on your disks. Formerly referred to as a directory.

Font

A complete set of characters of the same size and style, for example, 12-point Courier bold.

Form

A custom paper size, with width and height defined by the user.

G

Grayscale image

A bitmap image that stores data for each dot as a shade of gray, rather than as black or white.

H

Halftone

The process of converting a grayscale image to black dots and white (unprinted) dots that simulate the gray shades in the original image.

I

Interface

The connection between two devices through which they communicate with each other. The LBP-1120 printer features USB interface, which makes it compatible with IBM and similar personal computers.

Interface cable

The cable, with bi-directional capability, used to create the interface between a printer and a computer.

Interface port

The port through which the printer communicates with the computer. The LBP-1120 has a USB port located on the back of the printer. See also USB interface.

Italic

A font style distinguished by slanted characters (the upright strokes of the characters are at an angle to the vertical axis).

J

Jam

A situation created when paper becomes caught along the paper path. You must remove jammed paper before you can continue printing.

K

Kilobyte (KB)

A unit of measurement, representing the binary number 1024, used to describe printer or computer memory size in thousand-byte units.

L

Landscape

The printing of text and graphics along the length of the page.

Local printer

A printer that is directly connected to your computer, using a USB cable.

M

Megabyte (MB)

A unit of measurement, representing one million bytes, used to describe printer or computer memory size.

My Computer

The Windows program that you can use to browse through your computer's filing system, and to open drives, folders, and files. You can also use My Computer to manage your files and your filing system, by moving, copying, renaming, and deleting items.

N

Network

A group of computers connected by cables or other means and using software that enables them to share equipment (such as printers) and exchange information.

O

Orientation

The printing of text either along the width (portrait) or length (landscape) of the page.

Overlay

Refers to printing in which data that is common to all the pages, such as a logo, titles or table structure, is overlaid with the print data from the application.

www.DataSheet4U.com

P

Paper feed

The act of guiding a sheet of paper into the printer's paper path.

Paper jam

A situation created when paper becomes caught along the paper path. You must remove jammed paper before you can continue printing.

Paper path

The route that paper travels through the printer.

PDF

Stands for Portable Document Format. A widely used format for transmitting and viewing documents on computers. PDF documents can be read or printed out with Adobe's Acrobat Reader program.

Peer-to-peer connection

A network connection between a computer and a printer (or other device) that does not go through a server. See also Server, Client.

Physical RAM

Random access memory (RAM) that is physically present in the computer in the form of memory chips, as opposed to virtual memory. See also Virtual Memory.

Point size

Character height is defined in points: one point is 1/72 of an inch.

Portrait

The printing of text along the width (short edge) of the page.

Print job

A document that a Windows application has processed and sent to the Spooler to be added to the print queue or directly to the printer.

Print queue

A list of files that are either waiting to be printed or are currently printing. Once a file has been printed, it is removed from the print queue.

Printer driver

A program that controls how the computer and printer interact. The printer driver supplies Windows with information such as descriptions of fonts and features of the installed printer. When you print with the Canon Advanced Printing Technology, you are using its printer driver.

www.DataSheet4U.com

Printers folder

The container in which your printer information is stored.

Profile

A profile is a file that stores the printer's settings, so those settings can be recreated simply by selecting the profile from a menu.

Progress bar

In the Status Window or its icon, a horizontal bar that graphically indicates the percentage of the print job that has actually printed.

Properties dialog box

The dialog box that contains information about a particular device, such as your printer.

Proportional spacing

The spacing of characters according to the width of each character. This variable spacing between each character closes up awkward space and makes text easier to read.

Q

Queue

A list of files that are either waiting to be printed or are currently printing. Once a file has been printed, it is removed from the print queue.

R

Random Access Memory (RAM)

The working memory of the computer in which programs and data are temporarily stored while you use them. Resetting or shutting off the computer clears all information from RAM. Printing very complicated documents might require closing other running programs or adding more RAM to the computer. See also Physical RAM, Virtual memory.

Resolution

The density of dots for any given output device, expressed in terms of dots per inch (dpi). Low resolution causes font characters and graphics to have a jagged appearance, but prints faster than higher resolutions. Higher resolution provides smoother curves and angles as well as a better match to traditional typeface designs, but prints more slowly. This printer can produce output with 300 or 600 dpi resolution. Resolution values are represented by horizontal data and vertical data, for example, 600 x 600 dpi.

S

Scalable fonts

Scalable fonts allow characters to be printed in various sizes and rotation angles. This is different from bitmap fonts, which are printed in fixed sizes and angles.

Scaling

Enlarging or reducing the printed image.

SCoA

SCoA is an original Canon print data compressor and forwarding technology, which utilizes the full potential of your computer to make CAPT high speed printing a reality. Further, as compression and forwarding are efficient, only a small amount of memory is used, and regardless of how much data you send, you do not need to increase RAM.

Separator page

Optional pages printed at the beginning of each document to help separate one print job from another.

Server

A network computer that is directly attached to the printer. The server controls the printer and handles print jobs sent from the clients. See also Client.

Shielded

A type of cable that contains a metallic sheath over the conductor material to protect the data passing through the cable from electromagnetic interference. You need to use a high-quality shielded interface cable with this printer.

Sound file

A file containing audio information that can be played by a sound driver. The Canon Advanced Printing Technology includes sound files that play to indicate printing conditions.

Spooling

A process by which an application sends a document to the Spooler, rather than directly to the printer, thus freeing the computer and application for other tasks. Spooled documents are printed in the order they are received.

Start menu

The menu that presents commands that are a starting point for all work you do on your computer, such as starting a program, opening a document, finding a file, and getting help. You open the Start menu by clicking the Start button displayed on the Desktop.

Status options

Settings which determine when the Printer Status Window opens and whether sounds play with messages.

Status Window

A window that the Canon Advanced Printing Technology uses to display messages about the current print job, as well as to graphically show the print job's progress from computer to printer.

T

Title bar

The horizontal bar that contains the title of a window or dialog box. On many windows, the title bar contains the Control menu box and Maximize and Minimize buttons.

Toner

A black, resin-coated powder contained in the EP-22 cartridge. The printer applies the toner to the surface of the photosensitive drum inside the printer via an electrophotographic mechanism.

Toner saver

Because only alternate data bits are printed, toner consumption is reduced.

Toolbar

In the Status Window, the area in the tab window that includes buttons for pausing, resuming, and deleting the current print job.

Transfer roller

Presses the paper against the drum, to aid the transfer of toner to the paper.

Trouble Shooter

A program that helps you solve printing problems. The Trouble Shooter checks the Windows configuration settings, and if possible corrects any errors that it finds.

TrueType fonts

Scalable fonts used for both screen display and printing. TrueType fonts can be sized to any height, and print exactly as they appear on the screen, but with higher resolution. See also Scalable font.

www.DataSheet4U.com

U

Universal Serial Bus (USB) interface

These are new serial interface standards. This bus automatically recognizes connections (Plug & Play) to allow plugging and unplugging connectors with the power still turned on to the PC or peripheral equipment.

V

Virtual Memory

Space on the hard disk that Windows uses for temporary data storage as if it were actually random access memory (RAM). Windows does this by means of a swap file. This provides Windows with more usable memory, but reduces speed of access to it when the swap file must be used. See also Physical RAM.

W

Weight

Refers to the thickness of a font: light, medium, or bold. Also refers to the thickness of paper.

Windows Explorer

The Windows program you can use to browse through, open, and manage the disk drives, folders, and files on your computer in a network system. You can also use Windows Explorer to view and open shared folders on other computers on the network. You can use Windows Explorer to manage your files by moving, copying, renaming, and deleting files.

WYSIWYG

Pronounced wizzy-wig, an acronym for "what you see is what you get." For example, when you format a paragraph, the line breaks that appear on the printed page are exactly the same as they are on the screen.

Index

A

- Add Paper
 - Message, 5-21
- Add Printer Wizard
 - For Windows 2000, 3-23
 - For Windows 98/Me, 3-15
 - For Windows XP, 3-31
- Automatic Image Refinement
 - Using, 3-76

C

- Canon LASER SHOT LBP-1120 Group
 - Described, 3-43
 - Help, 3-44
 - Status Window, 3-43
 - Trouble Shooter, 3-44
 - Uninstallation, 3-43
- CAPT(Canon Advanced Printing Technology)
 - Installing, 3-3
- CD-ROM Installation, 3-3
- Change paper to...
 - Message, 5-21
- Check Printer/Cable
 - Message, 5-21
- Check Toner Cartridge
 - Message, 5-21
- Cleaning Function
 - Described, 4-10
- Clear Paper Jam
 - Message, 5-22
- Close Printer Cover
 - Message, 5-22
- Collate, 3-63
- Colored Paper
 - Requirements, 2-4
- Condensation

- Preventing, 4-13
- Custom Paper Size
 - Selecting, 3-69

D

- Density
 - Toner, 3-74

E

- Envelopes
 - Loading in Multi-Purpose Tray, 2-16
 - Requirements, 2-5
- Error Messages, 5-21

F

- Face-Down Delivery Slot
 - Described, 1-4
- Face-Down Output Paper Support
 - Described, 1-4
- Face-Up Delivery Slot
 - Described, 1-4
- Finishing Tab
 - EMF Spooling, 3-63
 - Preferences, 3-56, 3-63
- Fixing Unit
 - Described, 1-6
- Front Cover
 - Described, 1-4

G

- Glossary, 6-4

H

Hardware Specifications, 6-2

Heavy or Thick Paper

Requirements, 2-4

Help Menu

Described, 3-82

I

Input Paper Support

Described, 1-4

Installing

For Windows 2000, 3-19

For Windows 98/Me, 3-3

For Windows XP, 3-29

Insufficient Memory

Message, 5-22

J

Job Menu

Described, 3-81

L

Label Sheets

Requirements, 2-5

Landscape

Orientation, 3-54, 3-61

List of Terms

Glossary, 6-4

M

Manual Feed Slot

Described, 1-4

Printing from, 2-19

Messages

List of, 5-21

Multi-Purpose Tray

Described, 1-4

Loading, 2-11

N

Network

Connecting to, 3-38

Network Printer

Connecting through print server, 3-42

Status, 3-86

O

Options Menu

Described, 3-81

Overlay

Overview, 3-70

Printing with, 3-71

P

Page Setup Tab

Copies, 3-54, 3-61

Custom Paper Size, 3-55

Manual Scaling, 3-54, 3-62

Orientation, 3-54, 3-61

Output Size, 3-54, 3-61

Overlay, 3-55, 3-62

Page Layout, 3-54, 3-62

Page Order, 3-54, 3-62

Page Size, 3-54, 3-61

Paper Type, 3-54, 3-62

Profile, 3-54, 3-61

View Settings, 3-55, 3-62

Paper

Handling, 2-7

Inappropriate, 2-6

Specification, 2-2

Storing, 2-7

Paper Capacity

Paper Delivery Tray, 2-3

Paper Source, 2-3

- Paper Stack, 2-8
- Paper Delivery
 - Face-down, 2-9
 - Face-up, 2-9
 - Selecting, 2-8
- Paper Delivery Selector
 - Described, 1-4
- Paper Guides
 - Described, 1-4
- Paper Jam
 - Before Removing, 5-12
 - Clearing, 5-9
 - In paper feed area, 5-13
 - In the face-down delivery area, 5-17
 - In the face-up delivery area, 5-18
 - Near the imaging area, 5-15
- Paper Size
 - Abbreviations, 2-3
- Plain Paper
 - Requirements, 2-4
- Plug & Play
 - For Windows 2000, 3-19
 - For Windows 98/Me, 3-9
 - For Windows XP, 3-29
- Port Busy
 - Message, 5-22
- Portrait
 - Orientation, 3-54, 3-61
- Postcards
 - Requirements, 2-5
- Power Lamp
 - Described, 1-4
- Power Socket
 - Described, 1-5
- Power Switch
 - Described, 1-5
- Print Job
 - Delete, 3-81
 - Pause, 3-81
 - Resume, 3-81
- Print Quality
 - Selecting, 3-73
- Printer
 - Cleaning, 4-14
 - Handling, 4-16
 - Turning OFF, 1-8
 - Turning ON, 1-7
 - Using on network, 3-38
- Printer Properties
 - Accessing for Windows 2000/XP, 3-49
 - Accessing for Windows 98/Me, 3-49
 - Advanced Tab, 3-59
 - Details Tab, 3-52
 - Finishing Tab, 3-55
 - General Tab, 3-51, 3-57
 - Page Setup Tab, 3-53
 - Ports Tab, 3-58
 - Quality Tab, 3-56
 - Security Tab, 3-59
 - Select Forms Tab, 3-60
 - Sharing Tab, 3-53, 3-58
- Printing
 - Canceling, 3-48
 - Document, 3-47
 - Multiple pages on one sheet, 3-65
- Printing Failed
 - Message, 5-22
- Printing Options
 - For Windows 2000/XP, 3-57
 - For Windows 98/Me, 3-51
 - Restoring defaults, 3-80
 - Using, 3-51
 - View setting, 3-80
- Printing Preference
 - Accessing, 3-50
 - Finishing Tab, 3-63
 - Page Setup Tab, 3-61
 - Quality Tab, 3-64
- Problems
 - CAPT, 5-7
 - Print Quality, 5-4
 - Printer, 5-5
- Problems and Solutions Without Messages, 5-4
- Profiles
 - Adding, 3-79
 - Editing, 3-79
 - Overview, 3-77
 - Selecting, 3-77

Q

Quality Tab

- Brightness, 3-57, 3-64
- Contrast, 3-57, 3-64
- Halftoning, 3-56, 3-64
- More Options, 3-57, 3-64
- Resolution, 3-56, 3-64

R

Rating Label

- Described, 1-5

S

Scaling

- Automatically, 3-67
- Manually, 3-68

Select Forms Tab

- Change Forms, 3-60
- Selected Forms, 3-60

Service Error

- Message, 5-23

Specifications

- Hardware, 6-2
- Software, 6-3

Status Options

- Selecting, 3-84

Status Window

- Animation Area, 3-82
- Closing, 3-83
- Error Message Area, 3-82
- Job Information Area, 3-82
- Menu bar, 3-81
- Opening, 3-83
- Printer Icon, 3-82
- Printer Status Message Area, 3-82
- Progress Bar, 3-82
- Status Bar, 3-82
- Tab Window, 3-82
- Toolbar, 3-82

T

Terminology

- Glossary, 6-4

Toner Cartridge

- Before replacing, 4-3
- Handling, 4-11
- Recycling, 4-10
- Replacing, 4-2, 4-6
- Storing, 4-13

Toner Density

- Adjusting, 3-74

Transfer Roller

- Described, 1-6

Transparencies

- Requirements, 2-4

Trouble Shooter

- Features, 5-19
- Starting, 5-19

U

Uninstalling

- CAPT, 3-45

USB Port Interface Connector

- Described, 1-5

V

Ventilation Slots

- Described, 1-5

6

Appendix

Canon

CANON INC.

30-2, Shimomaruko 3-chome, Ohta-ku, Tokyo 146-8501, Japan

CANON U.S.A., INC.

One Canon Plaza, Lake Success, NY 11042, U.S.A.

CANON CANADA INC.

6390 Dixie Road Mississauga, Ontario L5T 1P7, Canada

CANON EUROPA N.V.

Bovenkerkerweg 59-61 P.O. Box 2262, 1180 EG Amstelveen, The Netherlands

CANON COMMUNICATION & IMAGE FRANCE S.A.

102, avenue du Général de Gaulle 92257 La Garenne-Colombes Cedex, France

CANON (U.K.) LTD.

Woodhatch, Reigate, Surrey, RH2 8BF, United Kingdom

CANON DEUTSCHLAND GmbH

Europark Fichtenhain A10, 47807 Krefeld, Germany

CANON ITALIA S.p.A.

Palazzo L Strada 6 20089 Milanofiori Rozzano (MI) Italy

CANON LATIN AMERICA, INC.

703 Waterford Way Suite 400 Miami, Florida 33126 U.S.A.

CANON AUSTRALIA PTY. LTD

1 Thomas Holt Drive, North Ryde, Sydney, N.S.W. 2113, Australia

CANON SINGAPORE PTE. LTD.

79 Anson Road #09-01/06, Singapore 079906

CANON HONGKONG CO., LTD

9/F, The Hong Kong Club Building, 3A Chater Road, Central, Hong Kong