

Hole Pattern Proposal:

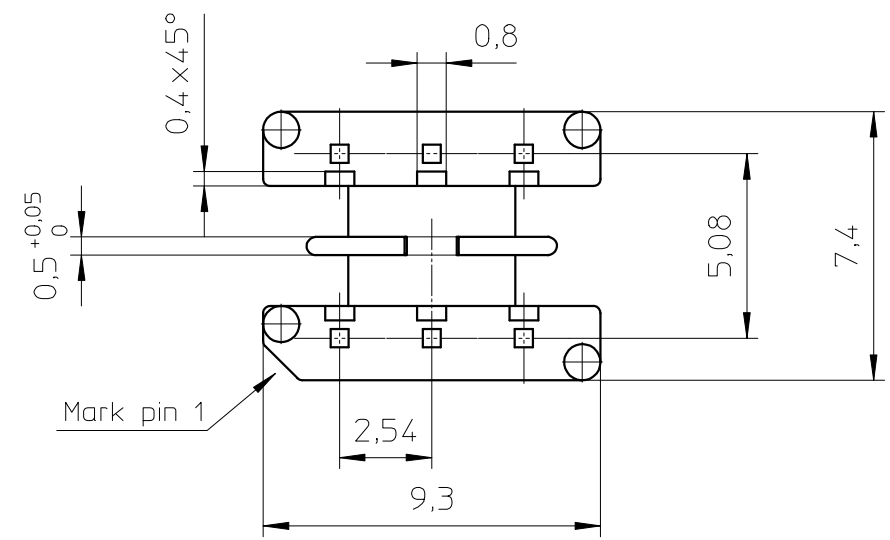

Coil former material: Sumikon PM9630 (PF), glass-reinforced.
 Pin material: Copperclad steel, Sn plated.
 Max. operating temp.: acc. to IEC 60 085 class H, 180°C.
 Resistance to soldering heat: acc. to IEC 60 068-2-20 Part 2, Test Tb, method 1B, 350°C-3.5s.
 Solderability: acc. to IEC 60 068-2-20 Part 2, Test Ta, method 1, 235°C-2s.
 Min. winding area: 3.5 mm²
 Mean length of turn: 18 mm.

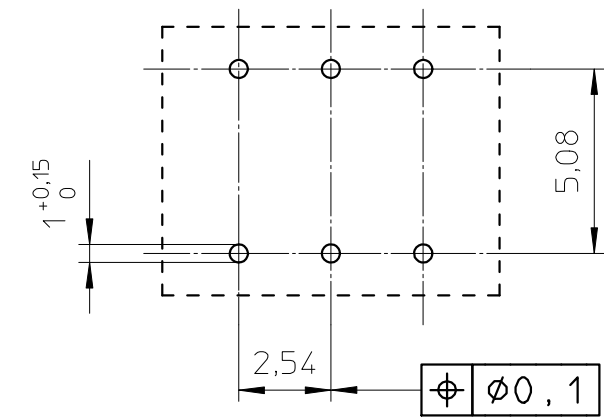
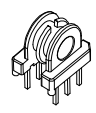

CLASS.NO.	CSH-EP7-2S-6P-IZ		30-08-2006
NAME NAAM	A.Wojtasz	SUPERS. VERV.	1 SH SH 112 - 001
MPA	CHECK CONTR.	DAT.	30-08-2006
Property of Eigendom van		© FERROXCUBE 2006	