

Surface Mount Lensed High Performance Chip LEDs

Technical Data

SunPower Series

HSMA-L640

HSMC-L640

HSMJ-L640

HSML-L640

Features

- **High Brightness AlInGaP Material**
- **Four Colors Available**
- **Compatible with IR Solder Process**
- **Narrow Viewing Angle**
- **Small 3.0 x 1.5 mm Package**
- **Available in 8 mm Tape on 7" (180 mm) Diameter Reels**

Applications

- **Keypad Backlighting**
- **Light Piping**
- **LCD Backlighting**
- **Front Panel Indicator**

Description

The HSMx-L640 is a Chip LED with an integrated lens. The lens concentrates the emitted light into a narrow viewing angle, which has the effect of doubling the on-axis intensity. These LEDs are optimum for light piping, backlighting buttons and switches, and applications, where as much flux as possible is required on axis.

These LEDs utilize aluminum indium gallium phosphide (AlInGaP) material technology. The AlInGaP material has a very high luminous efficiency, capable of producing high light output over a wide range of drive currents.

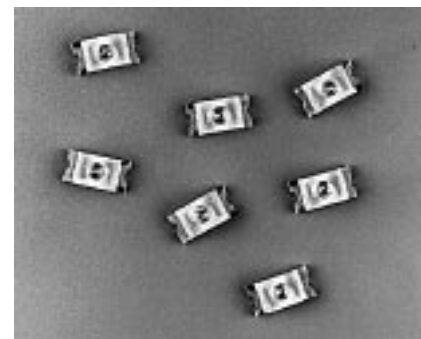

The available colors are 590 nm Amber, 605 nm Orange, 615 nm Red-Orange, and 626 nm Red.

The 3.0 x 1.5 mm package closely matches industry standard sizes for chip capacitors which makes it compatible with automated pick and place equipment.

This package is compatible with IR and convective reflow soldering processes.

Device Selection Guide

Amber 590 nm	Orange 605 nm	Red-Orange 615 nm	Red 626 nm
HSMA-L640	HSML-L640	HSMJ-L640	HSMC-L640

Package Dimensions

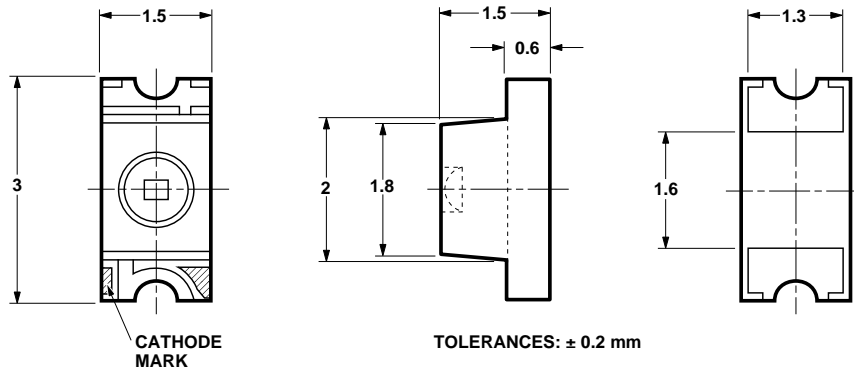

Notes:

1. Dimensions are in millimeters.
2. Tolerance, ± 0.2 mm

Absolute Maximum Ratings at $T_A = 25^\circ\text{C}$

Parameter	Value	Units
DC Forward Current ^{[3][4][5]}	30	mA
Power Dissipation	81	mW
Reverse Current $V_F = 5$ V	100	μA
Operating Temperature Range	-30 to +85	$^\circ\text{C}$
Storage Temperature Range ^[6]	-40 to +100	$^\circ\text{C}$

Notes:

3. Derate linearly as shown in Figure 4.
4. Drive currents between 1 mA and 30 mA are recommended for best long term performance.
5. Operating at currents below 1 mA is not recommended. Please contact your Agilent representative for further information.
6. Maximum temperature for tape and reel packaging is 60°C .

Optical Characteristics at $T_A = 25^\circ\text{C}$

Part Number	Color	Luminous Intensity I_V (mcd) @ I_F 20 mA ^[7]		Peak Wavelength λ_{peak} (nm) Typ.	Color, Dominant Wavelength λ_d ^[8] (nm) Typ.	Viewing Angle $2\theta_{1/2}$ Degrees ^[9] Typ.
		Min.	Typ.			
HSMA-L640	Amber	63	130	592	590	70
HSML-L640	Orange	63	130	609	605	70
HSMJ-L640	Red / Orange	63	100	621	615	70
HSMC-L640	Red	63	100	635	626	70

Notes:

7. The luminous intensity, I_V , is measured at the peak of the spatial radiation pattern.
8. The dominant wavelength, λ_d , is derived from the CIE Chromaticity diagram, and represents the perceived color of the device.
9. $\theta_{1/2}$ is the off-axis angle where the luminous intensity is $1/2$ the peak intensity.

Electrical Characteristics at $T_A = 25^\circ\text{C}$

Part Number	Color	Forward Voltage V_F (Volts) @ $I_F = 20\text{ mA}$		Reverse Breakdown V_R (Volts) @ $I_R = 100\ \mu\text{A}$ Min.	Capacitance C (pF) $V_F = 0$ $f = 1\text{ MHz}$ Typ.	Thermal Resistance $R\theta_{J-PIN}$ ($^\circ\text{C}/\text{W}$)
		Typ.	Max.			
HSMA-L640	Amber	2.02	2.4	5	40	500
HSML-L640	Orange	1.98	2.4	5	40	500
HSMJ-L640	Red / Orange	1.94	2.4	5	40	500
HSMC-L640	Red	1.90	2.4	5	40	500

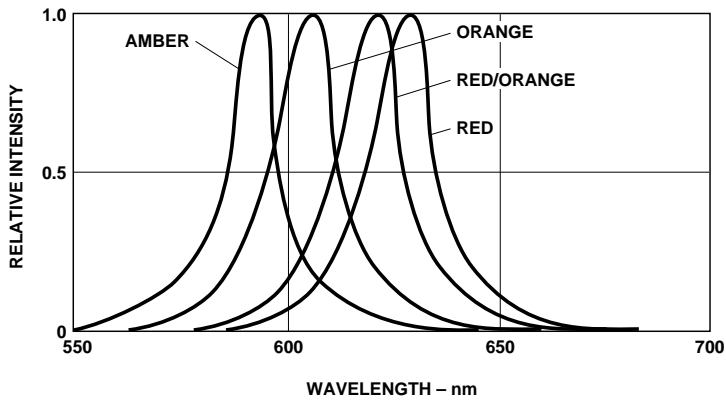

Figure 1. Relative Intensity vs. Wavelength.

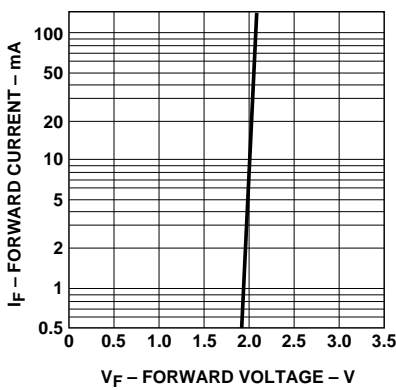

Figure 2. Forward Current vs. Forward Voltage.

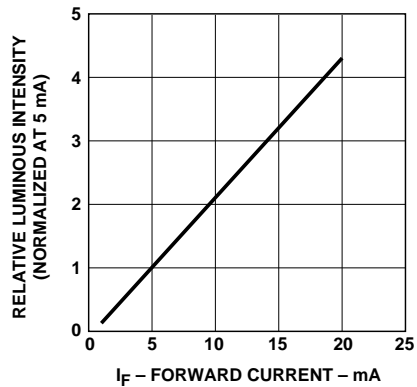

Figure 3. Relative Luminous Intensity vs. DC Forward Current.

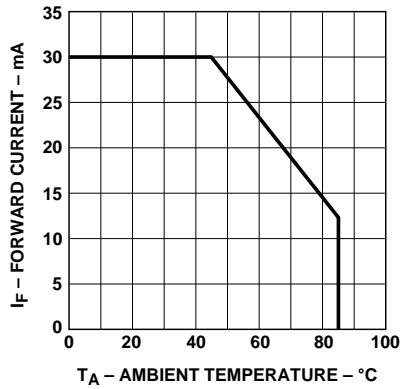

Figure 4. Maximum DC Current vs. Ambient Temperature.

Luminous Intensity Bin Limits^[10]

Bin ID	Minimum (mcd)	Maximum (mcd)
A	0.10	0.20
B	0.16	0.32
C	0.25	0.50
D	0.40	0.80
E	0.63	1.25
F	1.00	2.00
G	1.60	3.20
H	2.50	5.00
J	4.00	8.00
K	6.30	12.50
L	10.00	20.00
M	16.00	32.00
N	25.00	50.00
P	40.00	80.00
Q	63.00	125.00
R	100.00	200.00
S	160.00	320.00
T	250.00	500.00
U	400.00	800.00
V	630.00	1250.00
W	1000.00	2000.00
X	1600.00	3200.00
Y	2500.00	5000.00

Note:

10. Bin categories are established for classification of products. Products may not be available in all bin categories. Please contact your Agilent representative for information of currently available bins.

Amber Color Bins^{[10], [11]}

Bin ID	Minimum (nm)	Maximum (nm)
A	581.5	585.0
B	584.0	587.5
C	586.5	590.0
D	589.0	592.5
H	591.5	595.0
J	594.0	597.5

Orange Color Bins^{[10], [11]}

Bin ID	Minimum (nm)	Maximum (nm)
A	596.1	600.9
B	599.1	603.9
C	602.1	606.9
D	605.1	609.9
H	608.1	612.9

Red-Orange Color Bins^{[10], [11]}

Bin ID	Minimum (nm)	Maximum (nm)
A	610.0	617.0
B	615.0	621.0

Red Color Bins^{[10], [11]}

Bin ID	Minimum (nm)	Maximum (nm)
A	621.0	632.0

Notes:

10. Bin categories are established for classification of products. Products may not be available in all bin categories. Please contact your Agilent representative for information of currently available bins.
11. Dominant wavelength.
All products are shipped with one I_V bin and one color bin per reel.

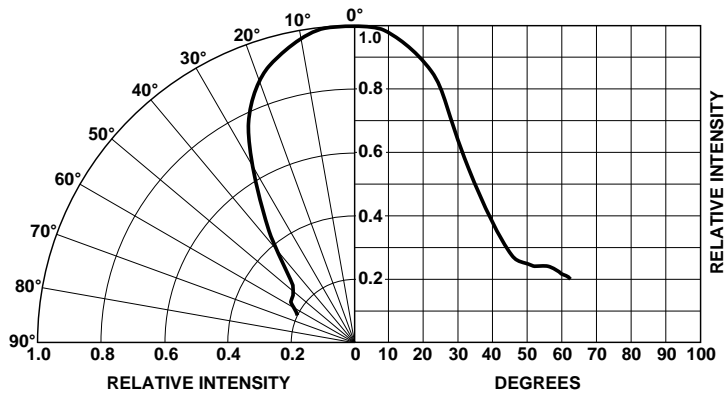

Figure 5. Intensity vs. Angle.

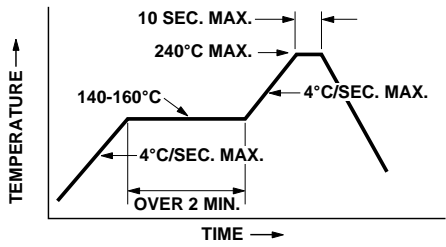

Figure 6. Recommended SMT Reflow Soldering Profile.

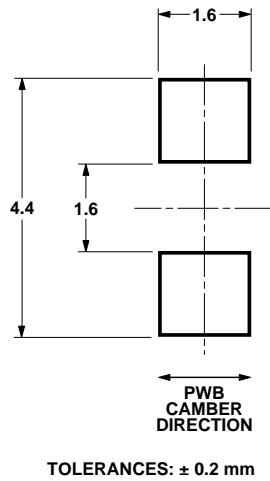

Figure 7. Recommended Solder Patterns.

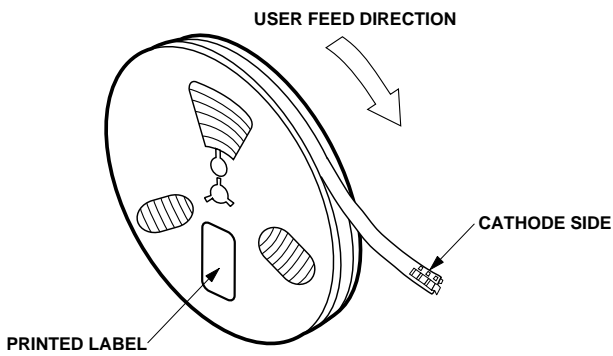

Figure 8. Reeling Orientation.

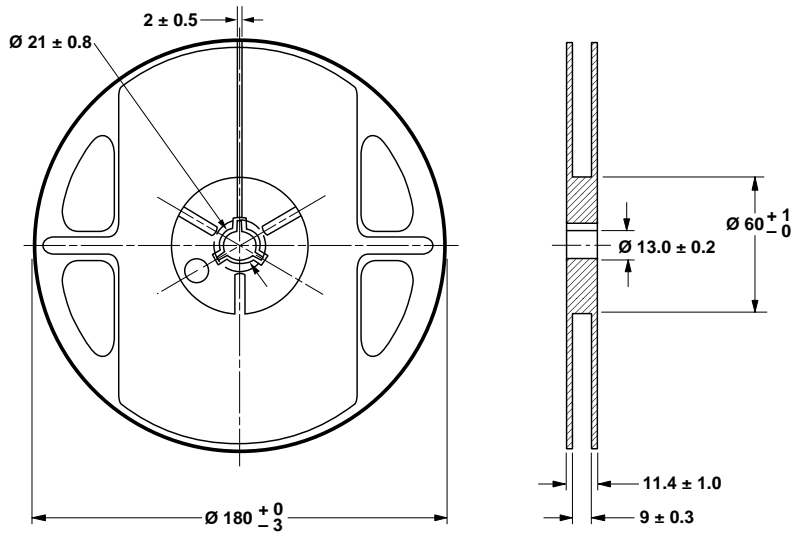

Figure 9. Reel Dimensions.

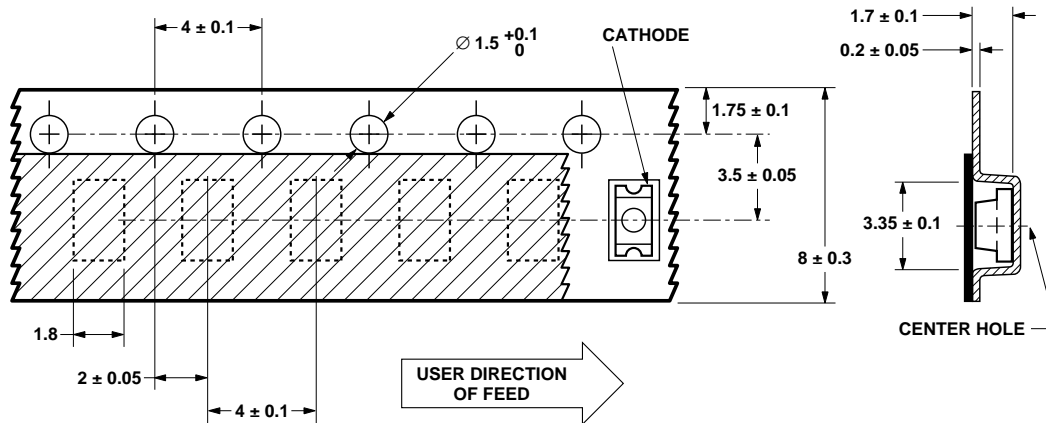

Figure 10. Tape Dimensions.

Storage Condition: 5 to 30° C
@ 60% RH max.

Baking is required under the
condition:

- the blue silica gel indicator becoming white/transparent color
- the pack has been opened for more than 1 week

Baking recommended condition:
60 +/- 5° C for 20 hours.

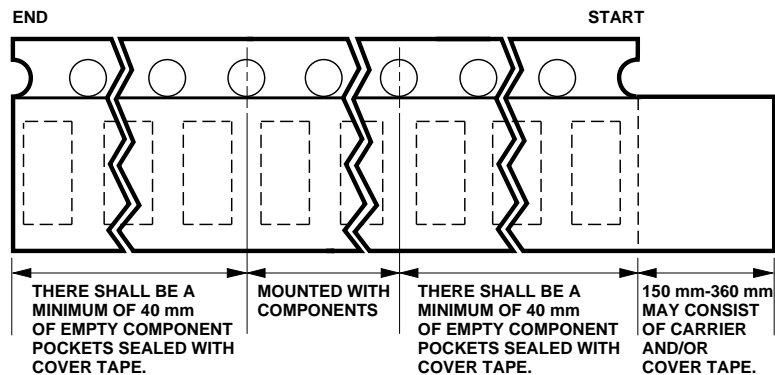
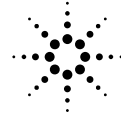

Figure 11. Tape Leader and Trailer Dimensions.



Agilent Technologies
Innovating the HP Way

www.semiconductor.agilent.com

Data subject to change.

Copyright © 2000 Agilent Technologies, Inc.

Obsoletes 5968-9898E

5980-2424E (8/00)