

MCO-SK-H-4p

SMD Clock Oscillator
HCMOS

QuartzCom
the communications company

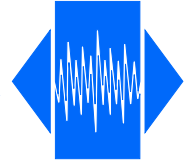

Features

- Applications: 10 Gigabit Ethernet, switching system and telecom infrastructure
- Output frequency up to 200 MHz
- Low Phase Noise
- Low Jitter < 0.3 ps.

Parameter	Specification	
	MCO-SK-3H-4p	MCO-SK-5H-4p
Frequency range	10 ~ 200 MHz	
Supply voltage	+3.3 V \pm 5 %	+5.0 V \pm 5 %
Supply current	7 ~ 45 mA	5 ~ 35 mA
Frequency stability (*)	\pm 20 ppm \pm 50 ppm	-20 ~ +70 °C -40 ~ +85 °C
Output signal	HCMOS	
Output level	$V_{OH} \geq 0.9$ Vdc	$V_{OL} \leq 0.1$ Vdc
Output load	15 pF	(25 ~ 50 pF on request)
Jitter (rms)	< 0.3 ps @ 12 kHz ~ 20 MHz from carrier frequency	
Symmetry	45 ~ 55 %	@ 1/2 Vdc
Rise / Fall time	1 ns	
Enable / Disable function	pin #1 = high or open pin #1 = low	pin #8 \rightarrow (E) enable pin #8 \rightarrow (D) disabled to Hi-Z
Operating temperature range	-20 ~ +70 °C -40 ~ +85 °C	commercial application industrial application
Storage temperature range	-55 ~ +125 °C	
Packaging units	tape & reel	500 pieces
(*) All inclusive: frequency stability, tolerance, aging, supply & load variation		
Customer specifications on request		

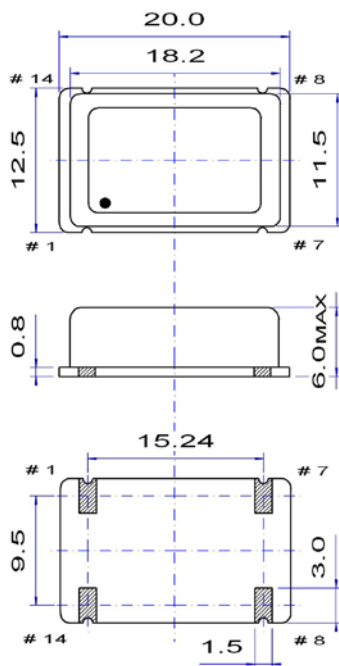

Pin function

- # 1 E/D or not connected
- # 7 GND
- # 8 Output
- # 14 Vdc

Example for solder pattern

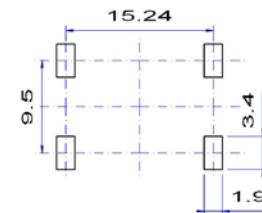

Do not design any conductive path between the pattern

Example for IR reflow soldering temperature

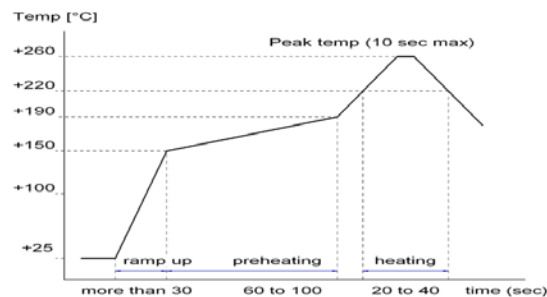

2002/95/EC RoHS compliant

03 May. 10

QuartzCom AG
sales@quartzcom.com

QuartzCom Asia
sales-asia@quartzcom.com

QuartzCom USA
sales-usa@quartzcom.com

www.quartzcom.com

ISO 9001
BUREAU VERITAS
Certification

