

Description

The Bay Linear B2026 & B2076 are a dual high-side power switch recommended for general Purpose self-powered and bus-powered universal serial bus (USB) application conforming to USB requirements. These devices include thermal shutdown which in fault modes reduces the current consumptions.

Additional features such as thermal shutdown to prevent catastrophic switch failure from excessively high current loads, under voltage lockout (UVLO) to ensure that the device remains off unless there is a valid input voltage present. These device it includes internal current limits. The 2026/76 offer a soft-start circuit for limit the inrush current and Fault status output flag for time over current and thermal shutdown status.

Bay Linear B2026/76 are available in 8-pin Dip and 8-pin SOIC packages.

Features

- 2.7V to 5.5V Input
- Under voltage Lockout
- 1µA Typical off-State Supply Current
- 500mA Minimum Continuous Load Current
- B2076 with Circuit Breaker Mode
- Logic Compatible Input
- Thermal Shutdown & Short Circuit protection
- Pin Compatible with B2526
- Replacement for MIC2026/76

Applications

- USB Host and self-Powered Hubs
- USB Power Management
- Battery-Charger Circuits
- Hot Plug-In Power Supplies
- Bus-Powered Hubs
- Notebooks/PDA
- ACPI power distribution

Package Information

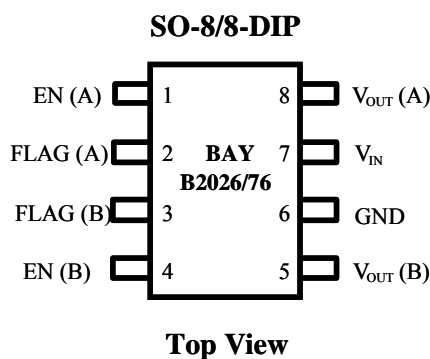

Ordering Information

Package	Enable	
	Active High	Active Low
SO-8	B2026-1M	B2026-2M
SO-8	B2076-1M	B2076-2M
8 DIP	B2026-1P	B2026-2P
8 DIP	B2076-1P	B2076-2P

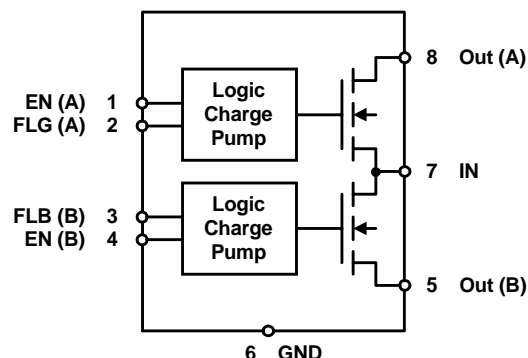

ABSOLUTE MAXIMUM RATINGS

Supply Voltage.....	+6V
Fault Flag Voltage.....	+6V
Fault Flag Current.....	25mA
Output Voltage.....	6V
Output Current.....	Internally Limited
Enable Input.....	-0.3V to +3V
Storage Temperature.....	-65°C to +150°C
Lead Temperature (Soldering 5 sec.).....	260°C

OPERATING RATING

Supply Voltage.....	+2.7V to +5.5V
Ambient Operating Temperature.....	-40°C to +85°C

Thermal Resistance

SOIC.....	160°C/W
DIP.....	105°C/W

ELECTRICAL CHARACTERISTICS at $V_{IN} = 5V$, $T_a = 25^\circ C$, unless otherwise specified. (Note 1)

Parameters		Typ			Units
		Min	Max		
Supply Current	Switch Off, OUT = Open $V_{ENA} = V_{EMB} \leq 0.8V$	0.75		5	μA
	Switch Off, OUT = Open $V_{ENA} = V_{EMB} \geq 2.4V$	0.75		5	
	Switch On, OUT = Open $V_{ENA} = V_{EMB} \leq 0.8V$	100		160	
	Switch On, OUT = Open $V_{ENA} = V_{EMB} \geq 2.4V$	100		160	
Enable Input Threshold	Low to High Transition	1.7			V
	High to Low Transition, (Note1)	1.45	0.8	2.4	
Enable Input Current	$V_{EN} = 0V$ to 5.5V	± 0.01	-1	1	μA
Enable Input Capacitance		1			pF
Switch Resistance	$V_{IN} = 5V$ $I_{OUT} = 500mA$, Each Switch	90		140	m Ω
	$V_{IN} = 3.3V$ $I_{OUT} = 500mA$, Each Switch	100		170	
Output Turn-On Delay	$R_L = 10\Omega$, $C_L = 1\mu f$	1.3		5	ms
Output Turn-On Rise Time	$R_L = 10\Omega$, $C_L = 1\mu f$	1.15		4.9	ms
Output Turn-Off Delay	$R_L = 10\Omega$, $C_L = 1\mu f$	35		100	μs
Output Turn-Off Fall Time	$R_L = 10\Omega$, $C_L = 1\mu f$	32		100	μs
Output Leakage Current	Each output (output disabled)			10	μA
Continuous Load Current	Each output	0.5			A
Short Circuit Current Limit	Each output (enable into load), $V_{OUT} = 0V$	0.9	0.5	1.25	A
Current Limit Threshold	Ramped Load applied to enable output, $V_{OUT} \leq 4.0V$	1.0		1.25	A
Over current Flag Response Delay	$V_{IN} = 5V$, apply $V_{OUT} = 0V$ UNTIL FLAG LOW	3.0	1.5	7.0	ms
	$V_{IN} = 3.3V$, apply $V_{OUT} = 0V$ UNTIL FLAG LOW	3.0			
Short Circuit Response Time	$V_{OUT} = 0V$ to $I_{OUT} = I_{LIMIT}$	20			μs
Error Flag Off Current	$V_{FLAG} = 5V$		0.01	1	μA
UVLO Threshold	$V_{IN} =$ Increasing	2.4	2.2	2.7	V
	$V_{IN} =$ Decreasing	2.15	2.15	2.5	

Advance Information- These data sheets contain descriptions of products that are in development. The specifications are based on the engineering calculations, computer simulations and/or initial prototype evaluation.

Preliminary Information- These data sheets contain minimum and maximum specifications that are based on the initial device characterizations. These limits are subject to change upon the completion of the full characterization over the specified temperature and supply voltage ranges.

The application circuit examples are only to explain the representative applications of the devices and are not intended to guarantee any circuit design or permit any industrial property right to other rights to execute. Bay Linear takes no responsibility for any problems related to any industrial property right resulting from the use of the contents shown in the data book. Typical parameters can and do vary in different applications. Customer's technical experts must validate all operating parameters including "Typical" for each customer application.

LIFE SUPPORT AND NUCLEAR POLICY

Bay Linear products are not authorized for and should not be used within life support systems which are intended for surgical implants into the body to support or sustain life, in aircraft, space equipment, submarine, or nuclear facility applications without the specific written consent of Bay Linear President.
