

### General Description

The LDS102P is a low voltage combined reference/amplifier suited for the control loop of low voltage power supplies. In order to allow operation down to very low voltages, the error amplifier output and the supply terminal have been isolated to separate functional pins. The nominal reference voltage is 600 mV, the COMP output can sink 20mA at 300mV.

Functionally, the LDS120 can be applied similarly to industry standard TL431, except that the reference is 600 mV and this requires a separate Vcc connection to a supply above 2.2V. Additionally, the output of the LDS120 can swing close to ground.

### Applications

- Power supply control loop
- Power supply supervisory functions
- Replacement for the MAX8515

### Features

- Low input voltage reference
- 600mV high accuracy voltage reference
- Low TC voltage reference
- High PSRR and line regulation
- Low current consumption
- Zero offset error amplifier
- Open collector output
- **RoHS compliant**

### Block Diagram

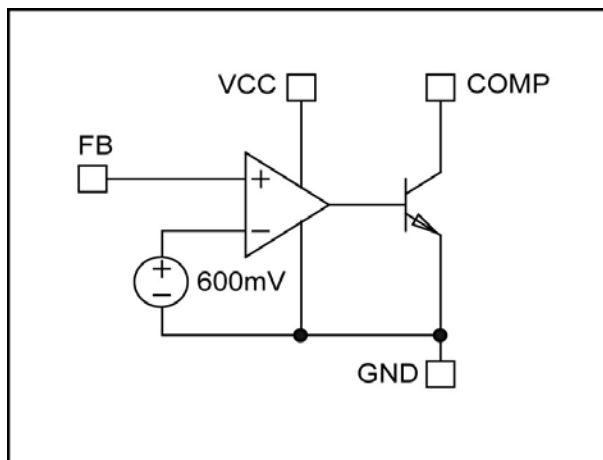

### Pin Configuration

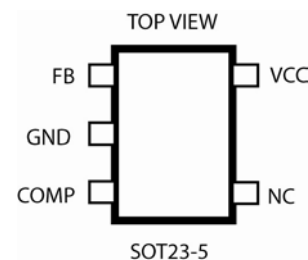

### Typical Application

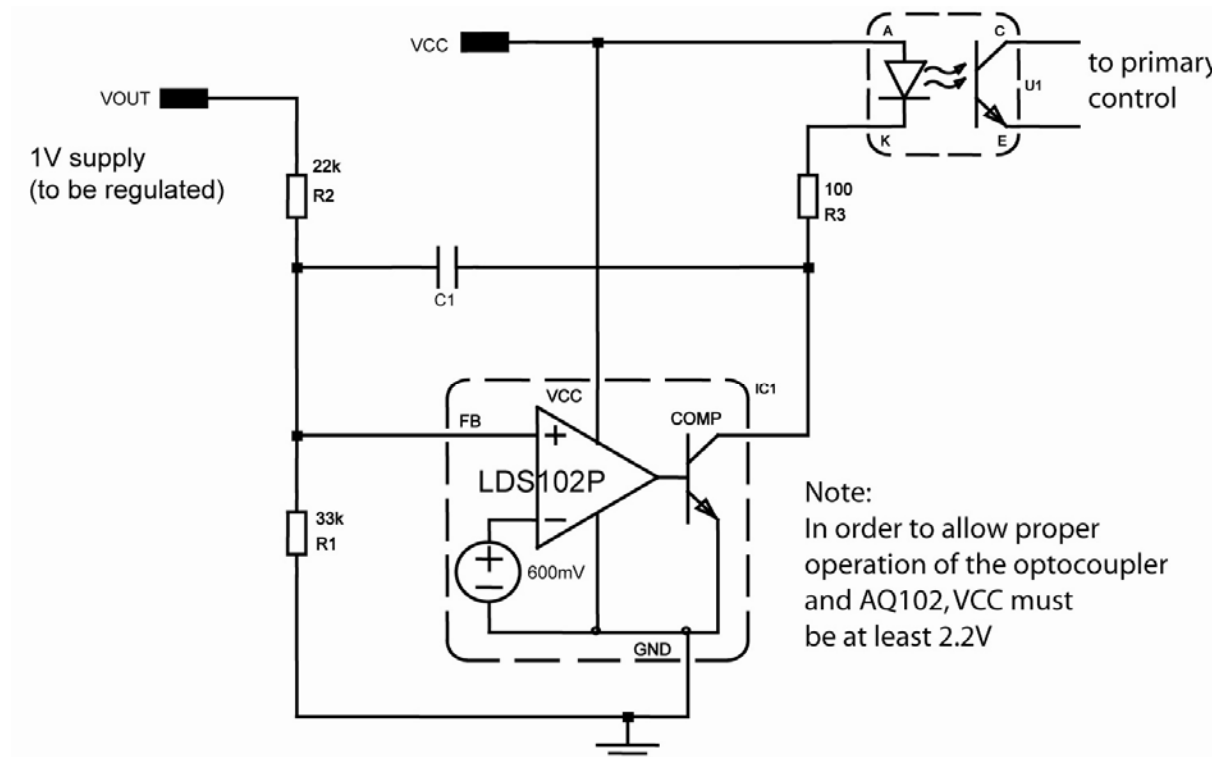

### Pin Descriptions

Pin	Pin Name	Function
1	FB	Inverting input to error amplifier; will have threshold of 600mV.
2	GND	Ground
3	COMP	Output of error amplifier; 20 mA source/sink capability
4	N/C	-
5	VCC	Positive supply

## Absolute Maximum Ratings

Parameter	Value	Units
V <sub>CC</sub> Voltage	20	V
COMP Voltage	20	V
REF Voltage	20	V
V <sub>CC</sub> , COMP, REF Current	50	mA
Operating Junction Temperature	150	°C
Lead Temperature (soldering 10 seconds)	260	°C
Storage Temperature Range	-65 to +150	°C

## Electrical Specifications

Electrical characteristics are guaranteed over the full temperature range  $-40^{\circ}\text{C} < T_j < 105^{\circ}\text{C}$ . Ambient temperature must be de-rated based upon power dissipation and package thermal characteristics. Unless otherwise stated, test conditions are V<sub>CC</sub> = 3V, V<sub>COMP</sub> = V<sub>FB</sub>, I<sub>COMP</sub> = 1mA

Symbol	Parameter	Conditions	Min	Typ	Max	Units
V <sub>ccmin</sub>	Minimum Input Voltage				2.2	V
I <sub>cc</sub>	Quiescent Supply Current	V <sub>COMP</sub> =1V		0.3	0.5	mA
V <sub>cc</sub>	Supply Voltage		2.2		18	V
V <sub>ref</sub>	Reference Voltage	T <sub>j</sub> =25°C	594	600	606	mV
		-40°C < T <sub>j</sub> < 105°C	592		608	
DV <sub>cc</sub>	Line regulation	2.2V < V <sub>CC</sub> < 18V		0.5	1	mV
DV <sub>iload</sub>	Load Regulation	I <sub>COMP</sub> =1mA to 10mA		4	8	mV
T <sub>cref</sub>	Reference Temperature Deviation	-40°C < T <sub>j</sub> < 105°C		25	50	ppm/°C
I <sub>FB</sub>	REF input current		-500		500	nA
PSRR	Reference Power Supply Rejection	Freq.=300KHz	35	45		dB
A <sub>v</sub>	Error Amplifier Open Loop Gain	I <sub>COMP</sub> =2mA, COMP=1V	60	80		dB
BW	Unity Gain Frequency	I <sub>COMP</sub> =2mA, COMP=1V	1	2		MHz
V <sub>COMP</sub>	Output Saturation Voltage	I <sub>COMP</sub> =20mA, V <sub>FB</sub> =700mV		100	250	mV
TRANSC	Output Transconductance	I <sub>COMP</sub> =1mA to 20mA		2.5		mA/mV
I <sub>leak</sub>	Output Leakage Current	V <sub>COMP</sub> =16 V <sub>FB</sub> =0		200	400	nA

## Typical Performance Characteristics

Line regulation (at 1mA)

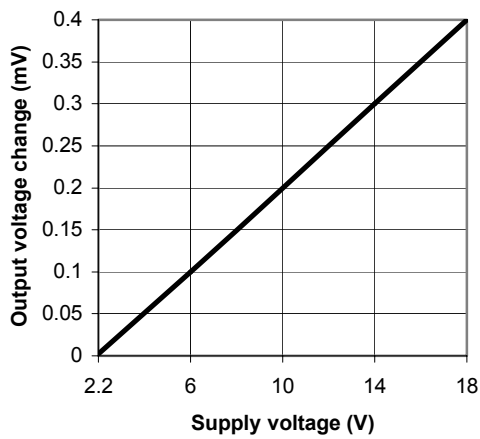

Load regulation

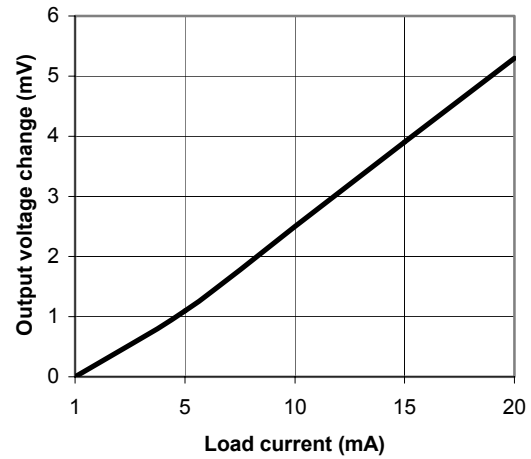

Supply current vs load current

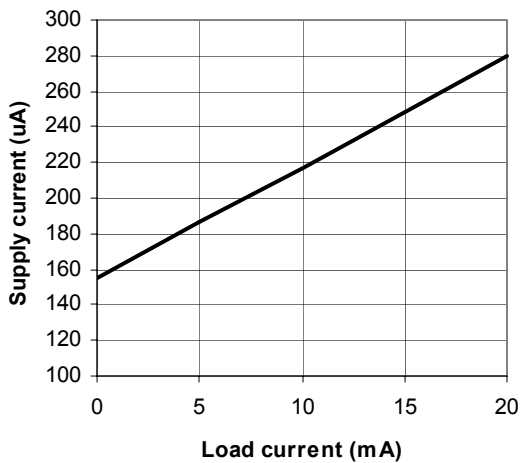

Power-supply rejection ratio vs frequency

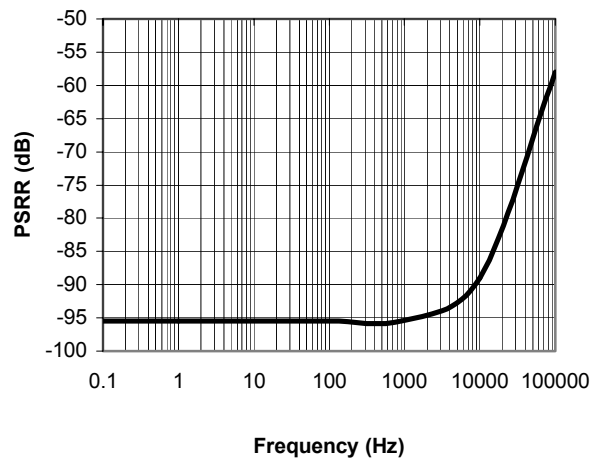

Typical Performance Characteristics (contd.)

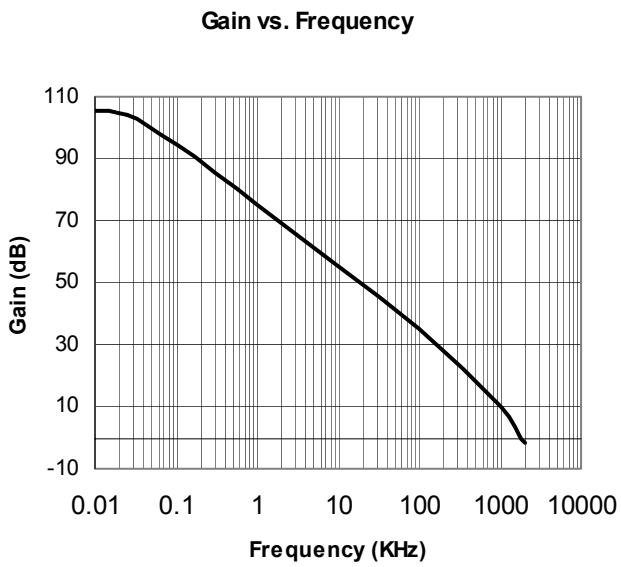
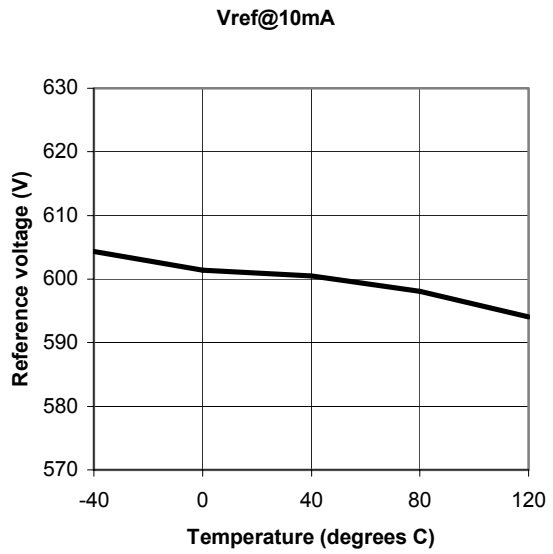
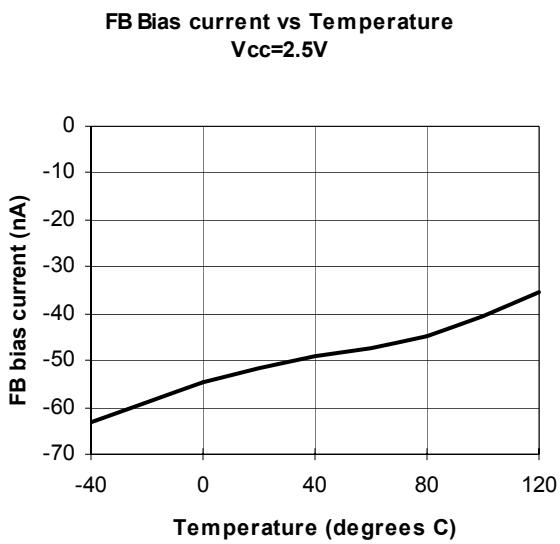

### Package Dimensions

### SOT23-3, SOT23-4, SOT23-5, SOT23-6

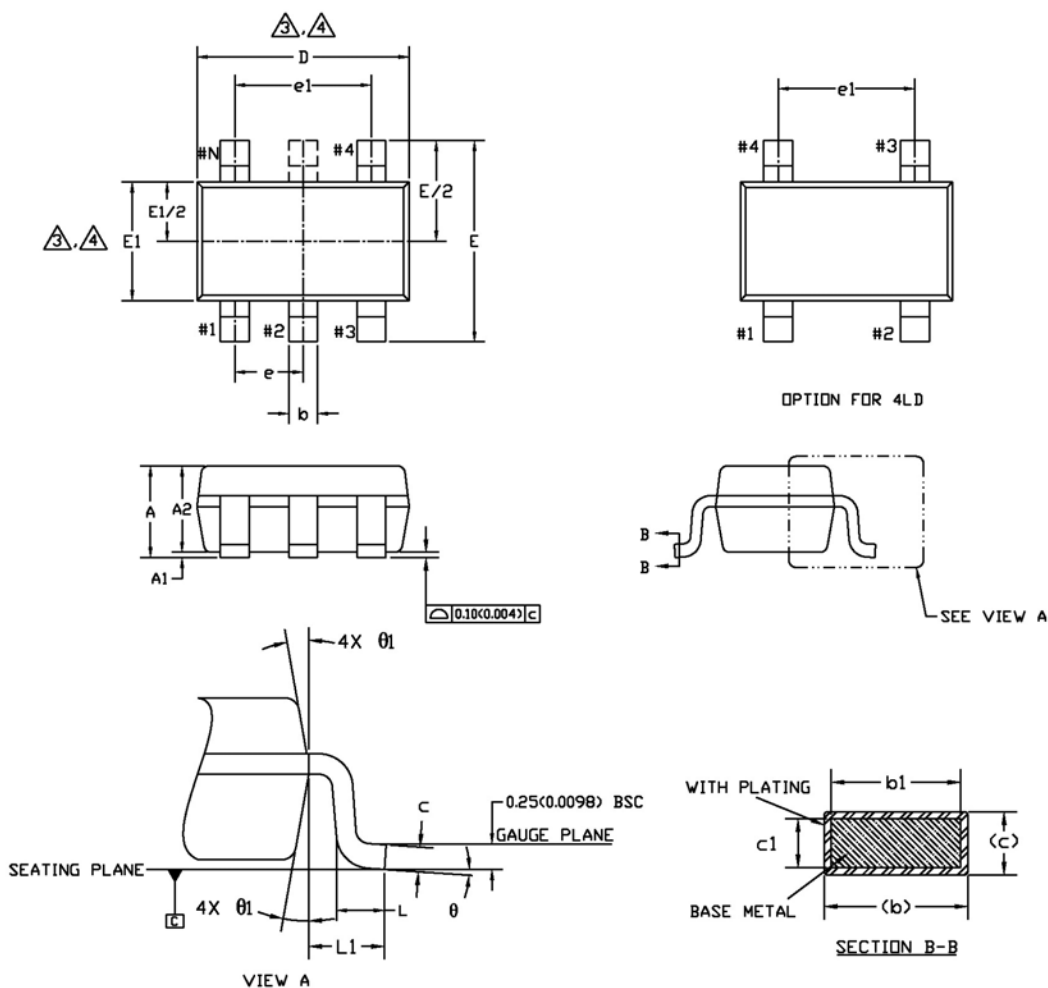

SYMBOL	COMMON					
	DIMENSIONS MILLIMETER			DIMENSIONS INCH		
	MIN.	NOM.	MAX.	MIN.	NOM.	MAX.
A	1.20	1.30	1.40	0.047	0.051	0.055
A1	0.05	-	0.15	0.002	-	0.006
A2	0.90	1.15	1.30	0.035	0.045	0.051
b	0.35	-	0.50	0.013	-	0.020
b1	0.35	0.40	0.45	0.013	0.015	0.017
c	0.08	-	0.22	0.003	-	0.008
c1	0.08	0.13	0.20	0.003	0.005	0.007
D	2.90 BSC			0.114 BSC		
E	2.80 BSC			0.110 BSC		
E1	1.60 BSC			0.062 BSC		
e	0.95 BSC			0.037 BSC		
e1	1.90 BSC			0.074 BSC		
L	0.35	0.45	0.55	0.013	0.017	0.021
L1	0.60 REF.			0.023 REF.		
theta	0°	4°	8°	0°	4°	8°
theta1	10° TYP			10° TYP		

NOTE :

1. Dimensioning and tolerancing per ASME Y 14.5 M - 1994.
2. Dimensions are in millimeters. Converted inch dimension are not necessarily exact.
3. Dimension D does not include mold flash, protrusions or gate burrs. Mold flash, protrusion or gate burrs shall not exceed 0.15 mm per side. Dimension E1 does not include interlead flash or protrusion. Interlead flash or protrusion shall not exceed 0.15 mm per side.
4. Top package may be smaller than the bottom package. Dimension D and E1 are determine at the outermost extremes of the plastic body exclusive of mold flash gate burrs and interlead flash.
5. Terminal numbers are shown for reference only. Die is facing up for molding. Die is facing down for trim/form.

---



---

## Ordering Information

Device	Operating Tj	%Tol	Pkg Type	Vout	Wrap	Ordering Number
LDS102P	-40C° ≤ 105C°	1.0	SOT-23-5	0.6V	T&R	LDS102BY-M5-06-TL

**Note:** Lead Free and RoHS compliant.

---

### Warranty and Use

*LEADIS TECHNOLOGY MAKES NO WARRANTY, REPRESENTATION OR GUARANTEE, EXPRESS OR IMPLIED, REGARDING THE SUITABILITY OF ITS PRODUCTS FOR ANY PARTICULAR PURPOSE, NOR THAT THE USE OF ITS PRODUCTS WILL NOT INFRINGE ITS INTELLECTUAL PROPERTY RIGHTS OR THE RIGHTS OF THIRD PARTIES WITH RESPECT TO ANY PARTICULAR USE OR APPLICATION AND SPECIFICALLY DISCLAIMS ANY AND ALL LIABILITY ARISING OUT OF ANY SUCH USE OR APPLICATION, INCLUDING BUT NOT LIMITED TO, CONSEQUENTIAL OR INCIDENTAL DAMAGES.*

Leadis Technology products are not designed, intended, or authorized for use as components in systems intended for surgical implant into the body, or other applications intended to support or sustain life, or for any other application in which the failure of the Leadis Technology product could create a situation where personal injury or death may occur.

Leadis Technology reserves the right to make changes to or discontinue any product or service described herein without notice. Products with data sheets labeled "Advance Information" or "Preliminary" and other products described herein may not be in production or offered for sale.

Leadis Technology advises customers to obtain the current version of the relevant product information before placing orders. Circuit diagrams illustrate typical semiconductor applications and may not be complete.

---



Leadis Technology  
 800 W. California Ave,  
 Suite 200  
 Sunnyvale, CA 94086  
 Phone: 408.331.8600  
 Fax: 408.331.8601  
<http://www.leadis.com>

Document No: 102LDS  
 Revision: 1.4  
 Issue date: 2/08/08