

● PROFESSIONAL LED INDICATORS Ø12.7mm Mounting

FEATURES

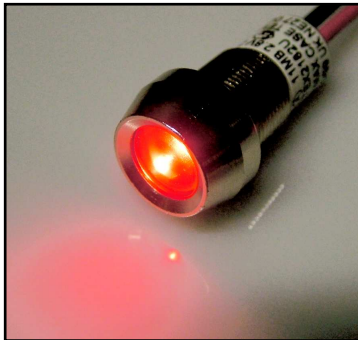

515 SERIES

PACK QUANTITY = 10 PIECES

- Bright nickel plated brass housing
- Atex approved to EN50028 (EN50014)
- Sealed to IP67
- Wide viewing angle
- Suitable for high vibration applications

SPECIFICATION

Ordering Information & Typical Technical Characteristics (Ta = 25°C)

Mean Time Between Failure = 100,000 Hours. Luminous intensity figures refer to the unmodified discrete LED.

PART NUMBER	COLOUR	LENS	VOLTAGE DC (Vdc) Vopr	CURRENT DC (mA) Iopr	LUMINOUS INTENSITY Iv@20mA (mcd)	WAVE LENGTH λp (nm)	OPERATING TEMP Topr	STORAGE TEMP Tstg	
HIGH INTENSITY									
515-501-04	Red	Colour Diffused	2.6	20	11000	624	-40 ~ +95 [^]	-40 ~ +100	Yes
515-521-04	Yellow	Colour Diffused	2.8	20	16000	591	-40 ~ +95 [^]	-40 ~ +100	Yes
515-532-04	Green	Colour Diffused	4.1	20	23000	527	-40 ~ +95 [^]	-40 ~ +100	Yes
515-930-04	Blue	Colour Diffused	4.1	20	7000	470	-40 ~ +95 [^]	-40 ~ +100	Yes
515-997-04	Cool White	Colour Diffused	4.1	20	14000	*	-40 ~ +95 [^]	-40 ~ +100	Yes
UNITS			Vdc	mA	mcd	nm	°C	°C	

* = Typical emission colour: cool white x=0.31, y=0.32

Intensities (Iv) and colour shades of white (x,y co-ordinates) may vary between LEDs within a batch.

[^] = Products must be derated when used above 45°C - Refer to fig 1.

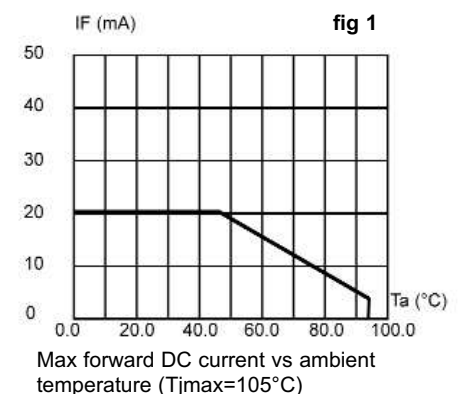

How to Order:

website: www.marl.co.uk • email: sales@marl.co.uk • webstore: www.leds.co.uk

• Telephone +44 (0)1229 582430 • Fax: +44 (0)1229 585155

The information contained in this datasheet does not constitute part of any order or contract and should not be regarded as a representation relating to either products or service. Marl International reserve the right to alter without notice the specification or any conditions of supply for products or service.

515 Series

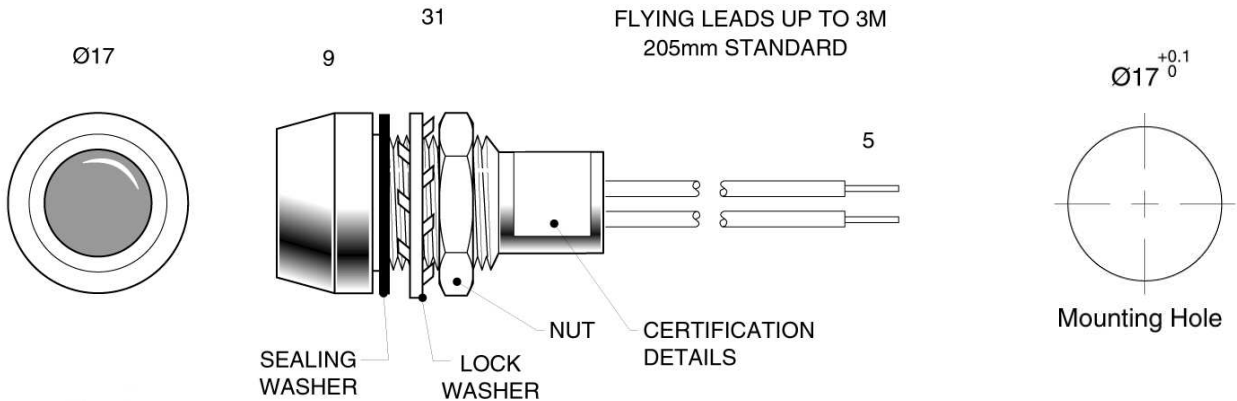

Dimensions in mm (Typical)
Not to scale

Anode termination indicated by red sleeve

MATERIALS

Body	Brass to BS 2874 CZ121 nickel plated BS 1224
Nut	Brass to BS 2874 CZ121 nickel plated BS 1224
Panel Seal	Viton
Cable	Zyrad 500
Fresnel lens	Polycarbonate
Clear Encapsulation	Stycast 1264A / 1264B catalyst
Blue Encapsulation	Stycast 2850FT / 24LV catalyst

TECHNICAL CHARACTERISTICS

SERIES	MAXIMUM POWER DISSIPATION	MAXIMUM REVERSE VOLTAGE	PANEL CUTOUT	MOUNTING TORQUE	MINIMUM MOUNTING CENTRES	MIN/MAX. PANEL THICKNESS	BODY	LOCK WASHER
515	1000	1000	12.7	1.0	x,y=19.5	1.5-5.0	Nickel Plated Brass	Zinc Plated Steel
UNITS	mw	Vdc	mm	Nm	mm	mm		

website: www.marl.co.uk • email: sales@marl.co.uk • webstore: www.leds.co.uk

• Telephone +44 (0)1229 582430 • Fax: +44 (0)1229 585155

The information contained in this datasheet does not constitute part of any order or contract and should not be regarded as a representation relating to either products or service. Marl International reserve the right to alter without notice the specification or any conditions of supply for products or service.