



### GENERAL DESCRIPTION



The ICS840002I-01 is a 2 output LVCMOS/LVTTL Synthesizer optimized to generate Ethernet reference clock frequencies and is a member of the HiPerClocks™ family of high performance clock solutions from ICS. Using a 25MHz 18pF parallel resonant crystal, the following frequencies can be generated based on the 2 frequency select pins (F\_SEL1:0): 156.25MHz, 125MHz, and 62.5MHz. The ICS840002I-01 uses ICS' 3<sup>rd</sup> generation low phase noise VCO technology and can achieve 1ps or lower typical random rms phase jitter, easily meeting Ethernet jitter requirements. The ICS840002I-01 is packaged in a small 16-pin TSSOP package.

### FEATURES

- Two LVCMOS/LVTTL outputs @ 3.3V, 17Ω typical output impedance
  - Selectable crystal oscillator interface or LVCMOS single-ended input
  - Supports the following output frequencies: 156.25MHz, 125MHz and 62.5MHz
  - Output frequency range: 56MHz - 175MHz
  - VCO range: 560MHz - 700MHz
  - Output skew: 12ps (maximum)
  - RMS phase jitter at 156.25MHz (1.875MHz - 20MHz): 0.47ps (typical)
- Phase noise:
- | Offset | Noise Power   |
|--------|---------------|
| 100Hz  | -97.4 dBc/Hz  |
| 1KHz   | -120.2 dBc/Hz |
| 10KHz  | -127.6 dBc/Hz |
| 100KHz | -126.1 dBc/Hz |
- Power supply modes:  
Core/Output  
3.3V/3.3V  
3.3V/2.5V  
2.5V/2.5V
  - -40°C to 85°C ambient operating temperature
  - Lead-Free package RoHS compliant

FREQUENCY SELECT FUNCTION TABLE

Inputs				Output Frequency (25MHz Ref.)
F_SEL1	F_SEL0	M Divider Value	N Divider Value	
0	0	25	4	156.25
0	1	25	5	125
1	0	25	10	62.5
1	1	25	5	125

### BLOCK DIAGRAM

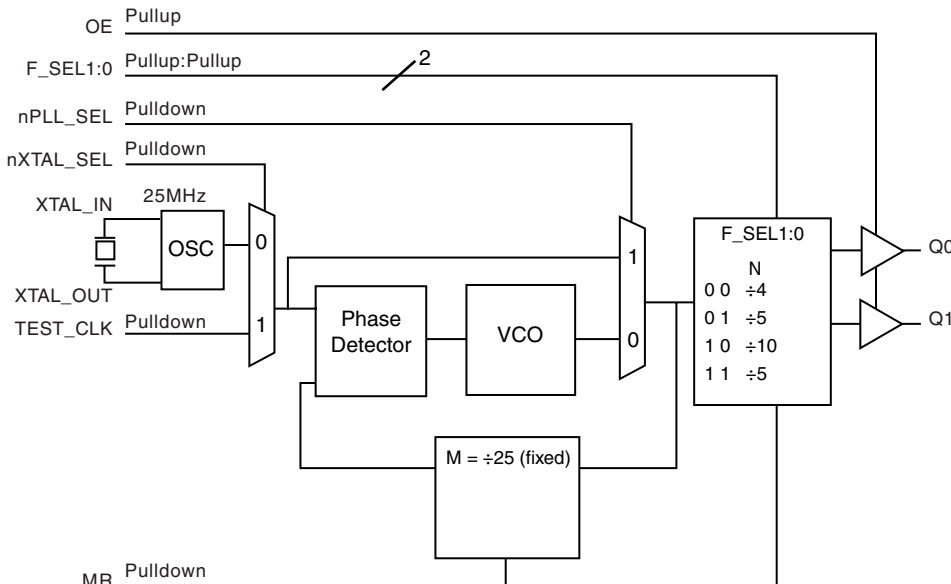

### PIN ASSIGNMENT

F_SEL0	1	16	F_SEL1
nXTAL_SEL	2	15	GND
TEST_CLK	3	14	GND
OE	4	13	Q0
MR	5	12	Q1
nPLL_SEL	6	11	VDDO
VDDA	7	10	XTAL_IN
VDD	8	9	XTAL_OUT

**ICS840002I-01**  
**16-Lead TSSOP**  
 4.4mm x 5.0mm x 0.92mm  
 package body  
**G Package**  
 Top View



**TABLE 1. PIN DESCRIPTIONS**

Number	Name	Type		Description
1, 16	F_SEL0, F_SEL1	Input	Pullup	Frequency select pin. LVCMOS/LVTTL interface levels.
2	nXTAL_SEL	Input	Pulldown	Selects between the crystal or TEST_CLK inputs as the PLL reference source. When HIGH, selects TEST_CLK. When LOW, selects XTAL input. LVCMOS/LVTTL interface levels.
3	TEST_CLK	Input	Pulldown	Single-ended LVCMOS/LVTTL clock input.
4	OE	Input	Pullup	Output enable pin. When HIGH, the outputs are active. When LOW, the outputs are in a high impedance state. LVCMOS/LVTTL interface levels.
5	MR	Input	Pulldown	Active HIGH Master Reset. When logic HIGH, the internal dividers are reset causing active outputs to go low. When logic LOW, the internal dividers and the outputs are enabled. LVCMOS/LVTTL interface levels.
6	nPLL_SEL	Input	Pulldown	PLL Bypass. When LOW, the output is driven from the VCO output. When HIGH, the PLL is bypassed and the output frequency = reference clock frequency/N output divider. LVCMOS/LVTTL interface levels.
7	V <sub>DDA</sub>	Power		Analog supply pin.
8	V <sub>DD</sub>	Power		Core supply pin.
9, 10	XTAL_OUT, XTAL_IN	Input		Crystal oscillator interface.
11	V <sub>DDO</sub>	Power		Output supply pin.
12, 13	Q1, Q0	Output		Single-ended clock outputs. LVCMOS/LVTTL interface levels.
14, 15	GND	Power		Power supply ground.

NOTE: *Pullup* and *Pulldown* refer to internal input resistors. See Table 2, Pin Characteristics, for typical values.

**TABLE 2. PIN CHARACTERISTICS**

Symbol	Parameter	Test Conditions	Minimum	Typical	Maximum	Units
C <sub>IN</sub>	Input Capacitance			4		pF
C <sub>PD</sub>	Power Dissipation Capacitance			8		pF
R <sub>PULLUP</sub>	Input Pullup Resistor			51		kΩ
R <sub>PULLDOWN</sub>	Input Pulldown Resistor			51		kΩ
R <sub>OUT</sub>	Output Impedance	3.3V±5%	14	17	21	Ω
		2.5V±5%	16	21	25	Ω



**ABSOLUTE MAXIMUM RATINGS**

Supply Voltage, $V_{DD}$	4.6V
Inputs, $V_I$	-0.5V to $V_{DD} + 0.5V$
Outputs, $V_O$	-0.5V to $V_{DD} + 0.5V$
Package Thermal Impedance, $\theta_{JA}$	89°C/W (0 lfpm)
Storage Temperature, $T_{STG}$	-65°C to 150°C

NOTE: Stresses beyond those listed under Absolute Maximum Ratings may cause permanent damage to the device. These ratings are stress specifications only. Functional operation of product at these conditions or any conditions beyond those listed in the *DC Characteristics* or *AC Characteristics* is not implied. Exposure to absolute maximum rating conditions for extended periods may affect product reliability.

**TABLE 3A. POWER SUPPLY DC CHARACTERISTICS,  $V_{DD} = V_{DDA} = 3.3V \pm 5\%$ ,  $V_{DDO} = 3.3V \pm 5\%$  OR  $2.5V \pm 5\%$ ,  $T_A = -40^\circ C$  TO  $85^\circ C$**

Symbol	Parameter	Test Conditions	Minimum	Typical	Maximum	Units
$V_{DD}$	Core Supply Voltage		3.135	3.3	3.465	V
$V_{DDA}$	Analog Supply Voltage		3.135	3.3	3.465	V
$V_{DDO}$	Output Supply Voltage		3.135	3.3	3.465	V
			2.375	2.5	2.625	V
$I_{DD}$	Power Supply Current				100	mA
$I_{DDA}$	Analog Supply Current				12	mA
$I_{DDO}$	Output Supply Current				5	mA

**TABLE 3B. POWER SUPPLY DC CHARACTERISTICS,  $V_{DD} = V_{DDA} = V_{DDO} = 2.5V \pm 5\%$ ,  $T_A = -40^\circ C$  TO  $85^\circ C$**

Symbol	Parameter	Test Conditions	Minimum	Typical	Maximum	Units
$V_{DD}$	Core Supply Voltage		2.375	2.5	2.625	V
$V_{DDA}$	Analog Supply Voltage		2.375	2.5	2.625	V
$V_{DDO}$	Output Supply Voltage		2.375	2.5	2.625	V
$I_{DD}$	Power Supply Current				95	mA
$I_{DDA}$	Analog Supply Current				12	mA
$I_{DDO}$	Output Supply Current				5	mA



**TABLE 3C. LVCMOS/LVTTL DC CHARACTERISTICS,  $V_{DD} = V_{DDA} = V_{DDO} = 3.3V \pm 5\%$  OR  $2.5V \pm 5\%$ , OR  $V_{DD} = V_{DDA} = 3.3V \pm 5\%$ ,  $V_{DDO} = 2.5V \pm 5\%$ ,  $T_A = -40^\circ\text{C}$  TO  $85^\circ\text{C}$**

Symbol	Parameter		Test Conditions	Minimum	Typical	Maximum	Units
$V_{IH}$	Input High Voltage		$V_{DD} = 3.3V$	2		$V_{DD} + 0.3$	V
			$V_{DD} = 2.5V$	1.7		$V_{DD} + 0.3$	V
$V_{IL}$	Input Low Voltage		$V_{DD} = 3.3V$	-0.3		0.8	V
			$V_{DD} = 2.5V$	-0.3		0.7	V
$I_{IH}$	Input High Current	OE, F_SEL0, F_SEL1	$V_{DD} = V_{IN} = 3.465V$ or $2.625V$			5	$\mu\text{A}$
		nPLL_SEL, MR, nXTAL_SEL, TEST_CLK	$V_{DD} = V_{IN} = 3.465V$ or $2.625V$			150	$\mu\text{A}$
$I_{IL}$	Input Low Current	OE, F_SEL0, F_SEL1	$V_{DD} = 3.465V$ or $2.625V$ , $V_{IN} = 0V$	-150			$\mu\text{A}$
		nPLL_SEL, MR, nXTAL_SEL, TEST_CLK	$V_{DD} = 3.465V$ or $2.625V$ , $V_{IN} = 0V$	-5			$\mu\text{A}$
$V_{OH}$	Output High Voltage; NOTE 1		$V_{DDO} = 3.3V \pm 5\%$	2.6			V
			$V_{DDO} = 2.5V \pm 5\%$	1.8			V
$V_{OL}$	Output Low Voltage; NOTE 1		$V_{DDO} = 3.3V$ or $2.5V \pm 5\%$			0.5	V

NOTE 1: Outputs terminated with  $50\Omega$  to  $V_{DDO}/2$ . See Parameter Measurement Information, Output Load Test Circuit.

**TABLE 4. CRYSTAL CHARACTERISTICS**

Parameter	Test Conditions	Minimum	Typical	Maximum	Units
Mode of Oscillation		Fundamental			
Frequency			25		MHz
Equivalent Series Resistance (ESR)				50	$\Omega$
Shunt Capacitance				7	pF

NOTE: Characterized using an 18pF parallel resonant crystal.

**TABLE 5A. AC CHARACTERISTICS,  $V_{DD} = V_{DDA} = V_{DDO} = 3.3V \pm 5\%$ ,  $T_A = -40^\circ\text{C}$  TO  $85^\circ\text{C}$**

Symbol	Parameter	Test Conditions	Minimum	Typical	Maximum	Units
$f_{OUT}$	Output Frequency	F_SEL[1:0] = 00	140		175	MHz
		F_SEL[1:0] = 01	112		140	MHz
		F_SEL[1:0] = 10 or 11	56		70	MHz
$t_{sk(o)}$	Output Skew; NOTE 1, 3				12	ps
$f_{jit}(\emptyset)$	RMS Phase Jitter (Random); NOTE 2	156.25MHz (1.875MHz - 20MHz)		0.47		ps
		125MHz (1.875MHz - 20MHz)		0.57		ps
		62.5MHz (1.875MHz - 20MHz)		0.51		ps
$t_R / t_F$	Output Rise/Fall Time	20% to 80%	200		700	ps
odc	Output Duty Cycle		46		54	%

NOTE 1: Defined as skew between outputs at the same supply voltages and with equal load conditions. Measured at  $V_{DDO}/2$ .

NOTE 2: Please refer to the Phase Noise Plot.

NOTE 3: This parameter is defined in accordance with JEDEC Standard 65.



**TABLE 5B. AC CHARACTERISTICS,  $V_{DD} = V_{DDA} = 3.3V \pm 5\%$ ,  $V_{DDO} = 2.5V \pm 5\%$ ,  $T_A = -40^\circ\text{C}$  TO  $85^\circ\text{C}$**

Symbol	Parameter	Test Conditions	Minimum	Typical	Maximum	Units
$f_{OUT}$	Output Frequency	F_SEL[1:0] = 00	140		175	MHz
		F_SEL[1:0] = 01	112		140	MHz
		F_SEL[1:0] = 10 or 11	56		68	MHz
$t_{sk(o)}$	Output Skew; NOTE 1, 3				12	ps
$f_{jit}(\emptyset)$	RMS Phase Jitter (Random); NOTE 2	156.25MHz (1.875MHz - 20MHz)		0.47		ps
		125MHz (1.875MHz - 20MHz)		0.55		ps
		62.5MHz (1.875MHz - 20MHz)		0.49		ps
$t_R / t_F$	Output Rise/Fall Time	20% to 80%	200		700	ps
odc	Output Duty Cycle		46		54	%

NOTE 1: Defined as skew between outputs at the same supply voltages and with equal load conditions.

Measured at  $V_{DDO}/2$ .

NOTE 2: Please refer to the Phase Noise Plot.

NOTE 3: This parameter is defined in accordance with JEDEC Standard 65.

**TABLE 5C. AC CHARACTERISTICS,  $V_{DD} = V_{DDA} = V_{DDO} = 2.5V \pm 5\%$ ,  $T_A = -40^\circ\text{C}$  TO  $85^\circ\text{C}$**

Symbol	Parameter	Test Conditions	Minimum	Typical	Maximum	Units
$f_{OUT}$	Output Frequency	F_SEL[1:0] = 00	140		175	MHz
		F_SEL[1:0] = 01	112		140	MHz
		F_SEL[1:0] = 10 or 11	56		68	MHz
$t_{sk(o)}$	Output Skew; NOTE 1, 3				12	ps
$f_{jit}(\emptyset)$	RMS Phase Jitter (Random); NOTE 2	156.25MHz (1.875MHz - 20MHz)		0.49		ps
		125MHz (1.875MHz - 20MHz)		0.56		ps
		62.5MHz (1.875MHz - 20MHz)		0.52		ps
$t_R / t_F$	Output Rise/Fall Time	20% to 80%	200		700	ps
odc	Output Duty Cycle		46		54	%

NOTE 1: Defined as skew between outputs at the same supply voltages and with equal load conditions.

Measured at  $V_{DDO}/2$ .

NOTE 2: Please refer to the Phase Noise Plot.

NOTE 3: This parameter is defined in accordance with JEDEC Standard 65.



**TYPICAL PHASE NOISE AT 62.5MHz @3.3V**

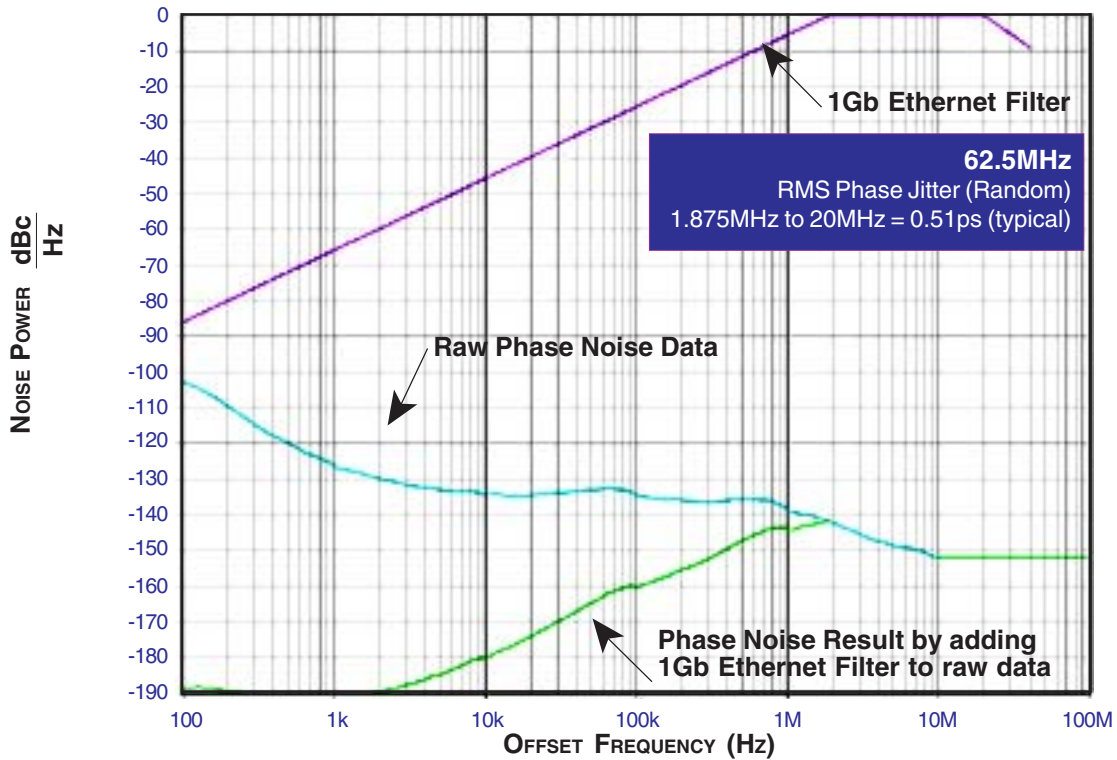

**TYPICAL PHASE NOISE AT 156.25MHz @3.3V**

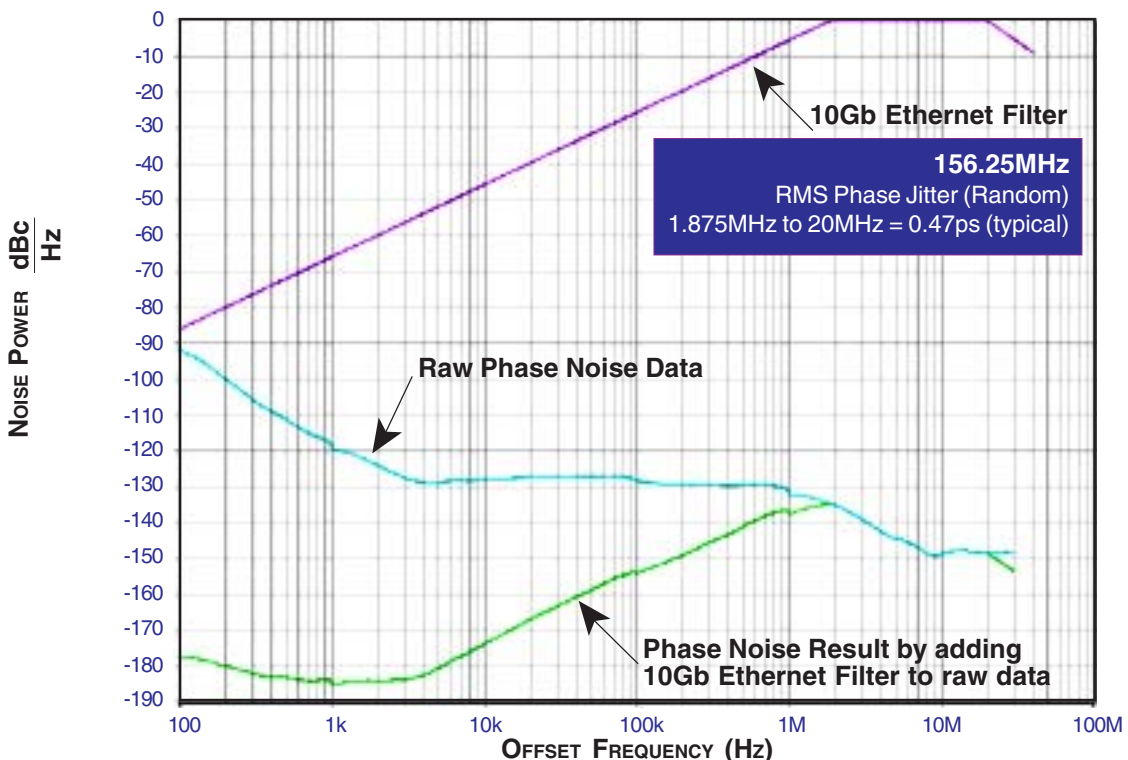



## PARAMETER MEASUREMENT INFORMATION

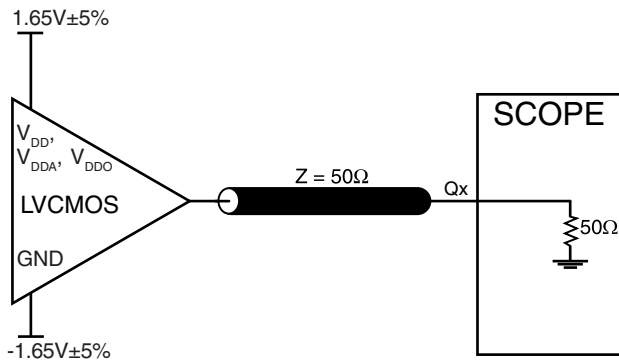

**3.3V CORE/3.3V OUTPUT LOAD AC TEST CIRCUIT**

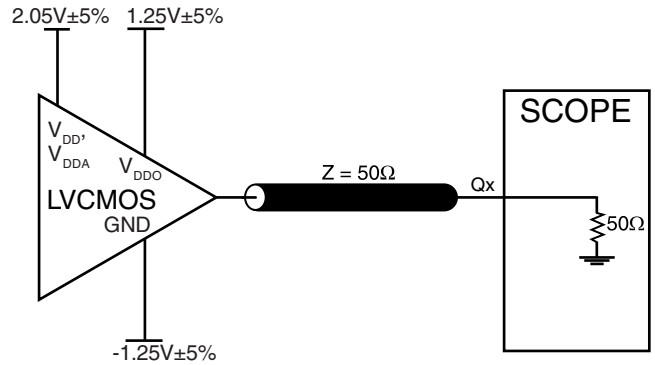

**3.3V CORE/2.5V OUTPUT LOAD AC TEST CIRCUIT**

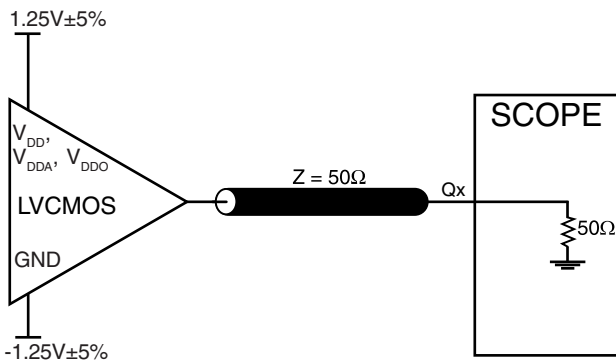

**2.5V CORE/2.5V OUTPUT LOAD AC TEST CIRCUIT**

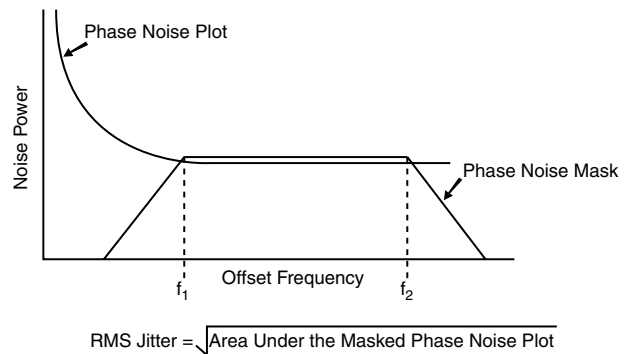

**RMS PHASE JITTER**

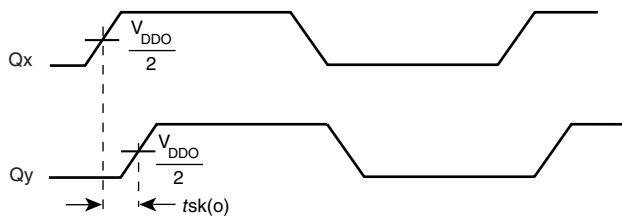

**OUTPUT SKEW**

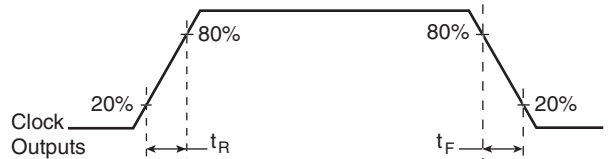

**OUTPUT RISE/FALL TIME**

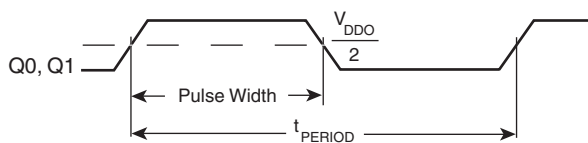

$$\text{odc} = \frac{t_{PW}}{t_{PERIOD}}$$

**OUTPUT DUTY CYCLE/PULSE WIDTH/PERIOD**



## APPLICATION INFORMATION

### POWER SUPPLY FILTERING TECHNIQUES

As in any high speed analog circuitry, the power supply pins are vulnerable to random noise. The ICS840002I-01 provides separate power supplies to isolate any high switching noise from the outputs to the internal PLL.  $V_{DD}$ ,  $V_{DDA}$ , and  $V_{DDO}$  should be individually connected to the power supply plane through vias, and bypass capacitors should be used for each pin. To achieve optimum jitter performance, power supply isolation is required. *Figure 1* illustrates how a  $10\Omega$  resistor along with a  $10\mu\text{F}$  and a  $.01\mu\text{F}$  bypass capacitor should be connected to each  $V_{DDA}$ .

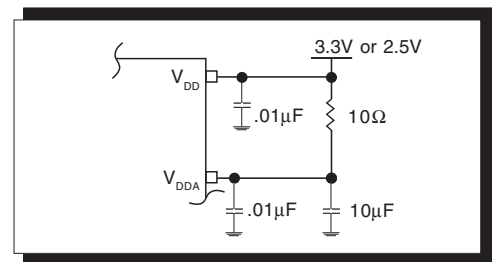

FIGURE 1. POWER SUPPLY FILTERING

### CRYSTAL INPUT INTERFACE

The ICS840002I-01 has been characterized with  $18\text{pF}$  parallel resonant crystals. The capacitor values shown in *Figure 2*

below were determined using a  $25\text{MHz}$   $18\text{pF}$  parallel resonant crystal and were chosen to minimize the ppm error.

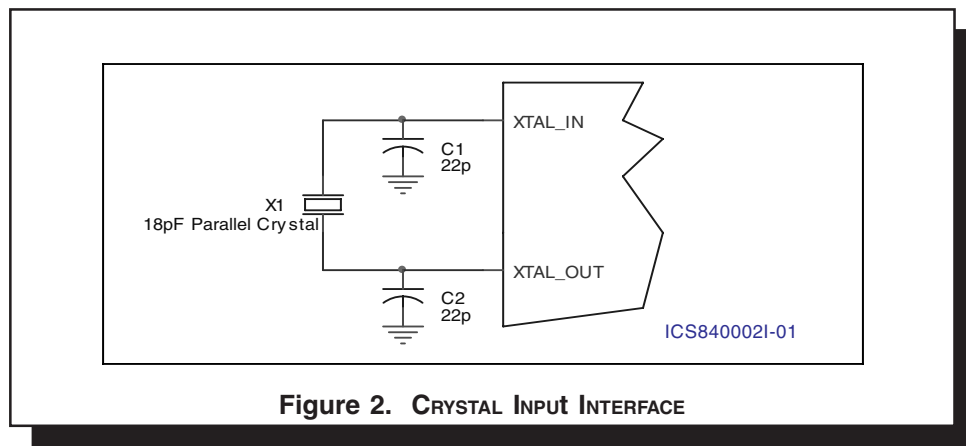

Figure 2. CRYSTAL INPUT INTERFACE





**LAYOUT GUIDELINE**

Figure 3 shows a schematic example of the ICS840002I-01. An example of LVCMOS termination is shown in this schematic. Additional LVCMOS termination approaches are shown in the LVCMOS Termination Application Note. In this example, an 18 pF parallel resonant 25MHz crystal is used. The C1=22pF and

C2=22pF are recommended for frequency accuracy. For different board layout, the C1 and C2 may be slightly adjusted for optimizing frequency accuracy. 1KΩ pullup or pulldown resistors can be used for the logic control input pins.

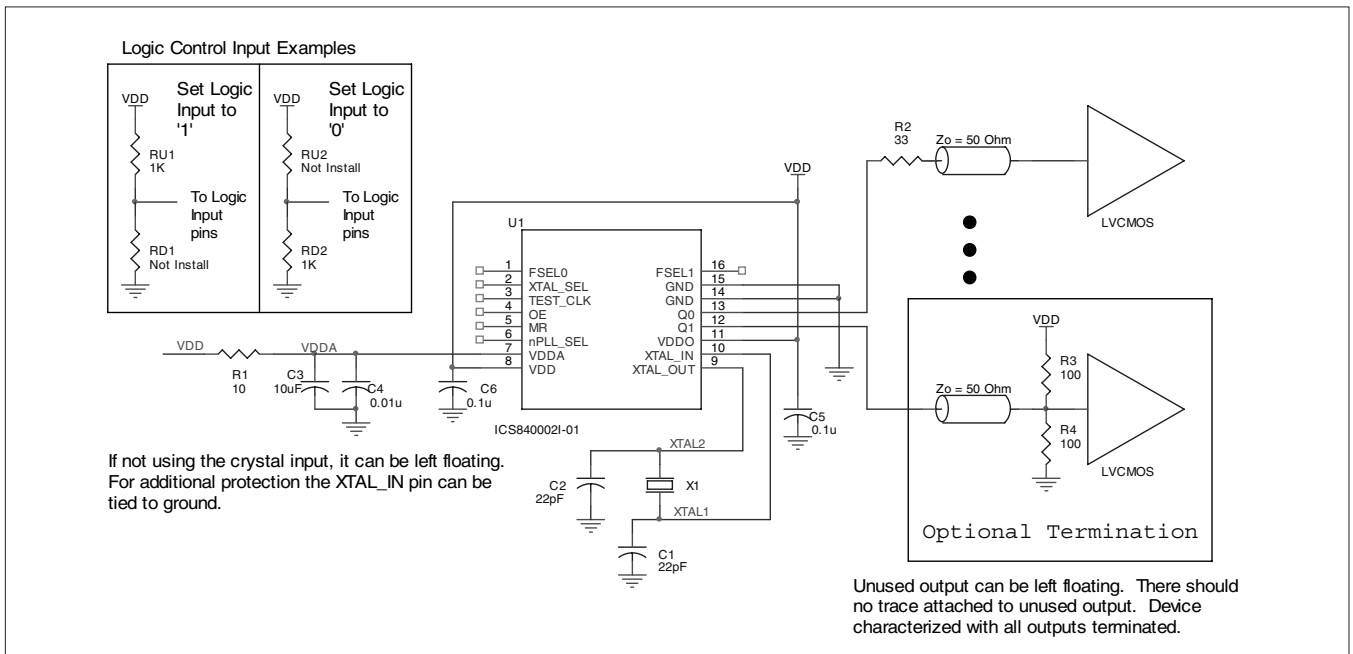

**FIGURE 3. ICS840002I-01 SCHEMATIC EXAMPLE**



## RELIABILITY INFORMATION

TABLE 6.  $\theta_{JA}$  vs. AIR FLOW TABLE FOR 16 LEAD TSSOP

$\theta_{JA}$ by Velocity (Linear Feet per Minute)			
	0	200	500
Single-Layer PCB, JEDEC Standard Test Boards	137.1°C/W	118.2°C/W	106.8°C/W
Multi-Layer PCB, JEDEC Standard Test Boards	89.0°C/W	81.8°C/W	78.1°C/W

**NOTE:** Most modern PCB designs use multi-layered boards. The data in the second row pertains to most designs.

### TRANSISTOR COUNT

The transistor count for ICS840002I-01 is: 3356



PACKAGE OUTLINE - G SUFFIX FOR 16 LEAD TSSOP

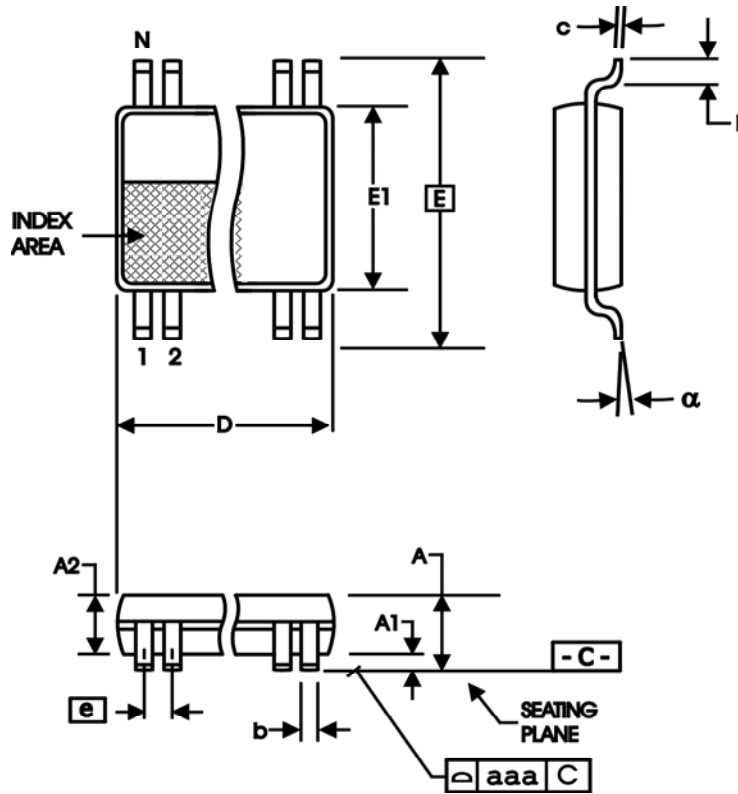

TABLE 7. PACKAGE DIMENSIONS

SYMBOL	Millimeters	
	Minimum	Maximum
N	16	
A	--	1.20
A1	0.05	0.15
A2	0.80	1.05
b	0.19	0.30
c	0.09	0.20
D	4.90	5.10
E	6.40 BASIC	
E1	4.30	4.50
e	0.65 BASIC	
L	0.45	0.75
α	0°	8°
aaa	--	0.10

Reference Document: JEDEC Publication 95, MO-153



Integrated  
Circuit  
Systems, Inc.

**ICS840002I-01**  
FEMTOCLOCKS™ CRYSTAL-TO-  
LVCMOS/LVTTL FREQUENCY SYNTHESIZER

**TABLE 8. ORDERING INFORMATION**

Part/Order Number	Marking	Package	Shipping Packaging	Temperature
ICS840002AGI-01	ICS840002AI01	16 Lead TSSOP	tube	-40°C to 85°C
ICS840002AGI-01T	ICS840002AI01	16 Lead TSSOP	2500 tape & reel	-40°C to 85°C
ICS840002AGI-01LF	TBD	16 Lead "Lead-Free" TSSOP	tube	-40°C to 85°C
ICS840002AGI-01LFT	TBD	16 Lead "Lead-Free" TSSOP	2500 tape & reel	-40°C to 85°C

The aforementioned trademarks, HiPerClockS™ and FEMTOCLOCKS™ are a trademark of Integrated Circuit Systems, Inc. or its subsidiaries in the United States and/or other countries. While the information presented herein has been checked for both accuracy and reliability, Integrated Circuit Systems, Incorporated (ICS) assumes no responsibility for either its use or for infringement of any patents or other rights of third parties, which would result from its use. No other circuits, patents, or licenses are implied. This product is intended for use in normal commercial and industrial applications. Any other applications such as those requiring high reliability or other extraordinary environmental requirements are not recommended without additional processing by ICS. ICS reserves the right to change any circuitry or specifications without notice. ICS does not authorize or warrant any ICS product for use in life support devices or critical medical instruments.