

1.5 AMP POSITIVE ADJUSTABLE VOLTAGE REGULATOR APPROVED TO DESC DRAWING 7703407



**Three Terminal, Precision Adjustable
 Positive Voltage Regulator In Hermetic
 Style Packages (LM117AHV)**

FEATURES

- Similar To Industry Standard LM117AHV
- Approved To DESC Standardized Military Drawing Number 7703407
- Built In Thermal Overload Protection
- Short Circuit Current Limiting
- Available In Six Package Styles
- Maximum Output Voltage Tolerance Is Guaranteed to $\pm 1\%$

DESCRIPTION

These three terminal positive regulators are supplied in hermetically sealed packages. All protective features are designed into the circuit, including thermal shutdown, current-limiting, and safe-area control. With heat sinking, these devices can deliver up to 1.5 amps of output current. The LCC-20 device is limited to .5 amps. The unit also features output voltages that can be fixed from 1.2 volts to 57 volts using external resistors.

ABSOLUTE MAXIMUM RATINGS $T_c @ 25^\circ\text{C}$

Power Dissipation	
Case 2	1.1 W
Case-All Others	20 W
Input - Output Voltage Differential	60 V
Operating Junction Temperature Range	- 55°C to + 150°C
Storage Temperature Range	- 65°C to + 150°C
Lead Temperature (Soldering 10 seconds)	300°C
Thermal Resistance, Junction to Case:	
Case 2, LCC-20	17°C/W
Case U & M, TO-257 (Isol) and SMD-3	4.2°C/W
Case T&N, TO-257 (Non-Isol) and SMD-1	3.5°C/W
Case Y, TO-3	3.0°C/W
Maximum Output Current:	
Case 2	.5 A
Case-All Others	1.5A
<u>Recommended Operating Conditions:</u>	
Output Voltage Range	1.2 to 57 VDC
Ambient Operating Temperature Range (T_A)	- 55°C to + 125°C
Input Voltage Range	4.25 to 61.25 VDC

3.5

ELECTRICAL CHARACTERISTICS -55°C T_A 125°C, $I_L = 8\text{mA}$ (unless otherwise specified)
OM1326NTM, OM1326STM, OM1326NKM, OM1326SMM, OM1326NMM

Parameter	Symbol	Test Conditions	Min.	Max.	Unit
Reference Voltage	V_{REF}	$V_{DIFF} = 3.0\text{V}$, $T_A = 25^\circ\text{C}$ $V_{DIFF} = 3.3\text{V}$ $V_{DIFF} = 40\text{V}$ $V_{DIFF} = 60\text{V}$	1.238 1.225 1.225 1.225	1.262 1.270 1.270 1.270	V
Line Regulation (Note 1)	R_{LINE}	$3.0\text{V } V_{DIFF} 40\text{V}$, $V_{out} = V_{ref}$, $T_A = 25^\circ\text{C}$ $3.3\text{V } V_{DIFF} 40\text{V}$, $V_{out} = V_{ref}$ $40\text{V } V_{DIFF} 60\text{V}$, $V_{out} = V_{ref}$, $T_A = 25^\circ\text{C}$ $40\text{V } V_{DIFF} 60\text{V}$, $V_{out} = V_{ref}$	-4.5 -9 -5 -10	4.5 -9 5 10	mV
Load Regulation (Note 1)	R_{LOAD}	$V_{DIFF} = 3.0\text{V}$, 10mA $I_L 1.5\text{A}$, $T_A = 25^\circ\text{C}$ $V_{DIFF} = 3.3\text{V}$, 10mA $I_L 1.5\text{A}$ $V_{DIFF} = 40\text{V}$, 10mA $I_L 300\text{mA}$, $T_A = 25^\circ\text{C}$ $V_{DIFF} = 40\text{V}$, 10mA $I_L 195\text{mA}$ $V_{DIFF} = 60\text{V}$, 10mA $I_L 30\text{mA}$	-15 -15 -15 -15 -15	15 15 15 15 15	mV
Thermal Regulation	V_{RTH}	$V_{in} = 14.6\text{V}$, $I_L = 1.5\text{A}$ $P_d = 20\text{ Watts}$, $t = 20\text{ ms}$, $T_A = 25^\circ\text{C}$	-5	5	mV
Ripple Rejection (Note 2)	R_N	$f = 120\text{ Hz}$, $V_{out} = V_{ref}$ $C_{Adj} = 10\text{ }\mu\text{F}$, $I_{out} = 100\text{ mA}$	66		dB
Adjustment Pin Current	I_{Adj}	$V_{DIFF} = 3.0\text{V}$, $T_A = 25^\circ\text{C}$ $V_{DIFF} = 3.3\text{V}$ $V_{DIFF} = 40\text{V}$ $V_{DIFF} = 60\text{V}$		100 100 100 100	μA
Adjustment Pin Current Change	I_{Adj}	$V_{DIFF} = 3.0\text{V}$, 10mA $I_L 1.5\text{A}$, $T_A = 25^\circ\text{C}$ $V_{DIFF} = 3.3\text{V}$, 10mA $I_L 1.5\text{A}$ $V_{DIFF} = 40\text{V}$, 10mA $I_L 300\text{mA}$, $T_A = 25^\circ\text{C}$ $V_{DIFF} = 40\text{V}$, 10mA $I_L 195\text{mA}$ $3.0\text{V } V_{DIFF} 40\text{V}$, $T_A = 25^\circ\text{C}$ $3.3\text{V } V_{DIFF} 40\text{V}$ $3.3\text{V } V_{DIFF} 60\text{V}$	-5 -5 -5 -5 -5 -5 -5	5 5 5 5 5 5 5	μA
Minimum Load Current	I_{Lmin}	$V_{DIFF} = 3.0\text{V}$, $V_{out} = 1.4\text{V}$ (forced) $V_{DIFF} = 3.3\text{V}$, $V_{out} = 1.4\text{V}$ (forced) $V_{DIFF} = 40\text{V}$, $V_{out} = 1.4\text{V}$ (forced) $V_{DIFF} = 60\text{V}$, $V_{out} = 1.4\text{V}$ (forced)		5.0 5.0 5.0 7.0	mA
Current Limit (Note 2)	I_{CL}	$V_{DIFF} = 5\text{V}$ $V_{DIFF} = 40\text{V}$, $T_A = 25^\circ\text{C}$ $V_{DIFF} = 60\text{V}$, $T_A = 25^\circ\text{C}$	1.5 0.3 0.05	3.5 1.5 0.50	A

Notes:

1. Load and Line Regulation are specified at a constant junction temperature. Pulse testing with low duty cycle is used. Changes in output voltage due to heating effects must be taken into account separately.
2. If not tested, shall be guaranteed to the specified limits.
3. The • denotes the specifications which apply over the full operating temperature range.

3.5

PART NUMBER DESIGNATOR		
Standard Military Drawing Number	Omnirel Part Number	Omnirel Package Designation
7703407M 7703407U 7703407T 7703407Y 7703407N 77034072	OM1326SMM OM1326STM OM1326NTM OM1326NKM OM1326NMM OM1326N2M	SMD-3 TO-257 (Isolated) TO-257 (non-Isolated) TO-3 SMD-1 LCC-20



ELECTRICAL CHARACTERISTICS -55°C T_A 125°C, I_L = 8mA (unless otherwise specified)

OM1326N2M

Parameter	Symbol	Test Conditions	Min.	Max.	Unit
Reference Voltage	V _{REF}	V _{DIFF} = 3.0V, T _A = 25°C	1.238	1.262	V
		V _{DIFF} = 3.3V	1.225	1.270	
		V _{DIFF} = 40V	1.225	1.270	
		V _{DIFF} = 60V	1.225	1.270	
Line Regulation (Note 1)	R _{LINE}	3.0V V _{DIFF} 40V, V _{out} = V _{ref} , T _A = 25°C	-4.5	4.5	mV
		3.3V V _{DIFF} 40V, V _{out} = V _{ref}	-9	-9	
		40V V _{DIFF} 60V, V _{out} = V _{ref} , T _A = 25°C	-5	5	
		40V V _{DIFF} 60V, V _{out} = V _{ref}	-10	10	
Load Regulation (Note 1)	R _{LOAD}	V _{DIFF} = 3.0V, 10mA I _L 500 mA, T _A = 25°C	-15	15	mV
		V _{DIFF} = 3.3V, 10mA I _L 500 mA	-15	15	
		V _{DIFF} = 40V, 10mA I _L 150 mA, T _A = 25°C	-15	15	
		V _{DIFF} = 40V, 10mA I _L 100 mA	-15	15	
Thermal Regulation	V _{RTH}	V _{in} = 14.6V, I _L = 300 mA	-2	2	mV
		P _d = 4.0 Watts, t = 20 ms, T _A = 25°C			
Ripple Rejection (Note 2)	R _N	f = 120 Hz, V _{out} = V _{ref} C _{Adj} = 10 μF, I _{out} = 100 mA	66		dB
Adjustment Pin Current	I _{Adj}	V _{DIFF} = 3.0V, T _A = 25°C		100	μA
		V _{DIFF} = 3.3V		100	
		V _{DIFF} = 40V		100	
		V _{DIFF} = 60V		100	
Adjustment Pin Current Change	I _{Adj}	V _{DIFF} = 3.0V, 10mA I _L 500 mA, T _A = 25°C	-5	5	μA
		V _{DIFF} = 3.3V, 10mA I _L 500 mA	-5	5	
		V _{DIFF} = 40V, 10mA I _L 150 mA, T _A = 25°C	-5	5	
		V _{DIFF} = 40V, 10mA I _L 100 mA	-5	5	
		3.0V V _{DIFF} 40V, T _A = 25°C	-5	5	
		3.3V V _{DIFF} 40V	-5	5	
Minimum Load Current	I _{Lmin}	V _{DIFF} = 3.0V, V _{out} = 1.4V (forced)		5.0	mA
		V _{DIFF} = 3.3V, V _{out} = 1.4V (forced)		5.0	
		V _{DIFF} = 40V, V _{out} = 1.4V (forced)		5.0	
		V _{DIFF} = 60V, V _{out} = 1.4V (forced)		7.0	
Current Limit (Note 2)	I _{CL}	V _{DIFF} = 5V	0.5	1.65	A
		V _{DIFF} = 40V, T _A = 25°C	0.15	0.65	
		V _{DIFF} = 60V, T _A = 25°C	0.02	0.28	

Notes: Please see page 34.

STANDARD APPLICATION

* C_{in} is required if regulator is located an appreciable distance from power supply filter.

** C_o is not needed for stability, however it does improve transient response.

$$V_{out} = 1.25 V \left(1 + \frac{R_2}{R_1} \right) + I_{Adj} R_2$$

Since I_{Adj} is controlled to less than 100 μA, the error associated with this term is negligible in most applications.

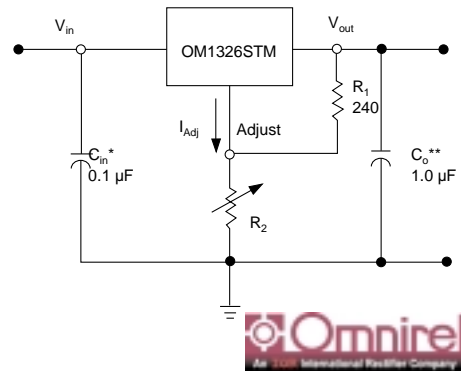

3.5



MECHANICAL OUTLINE

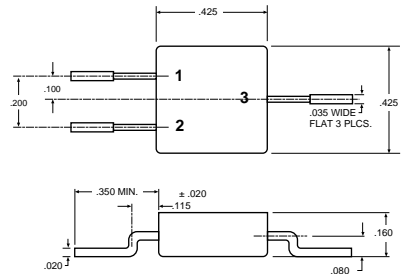
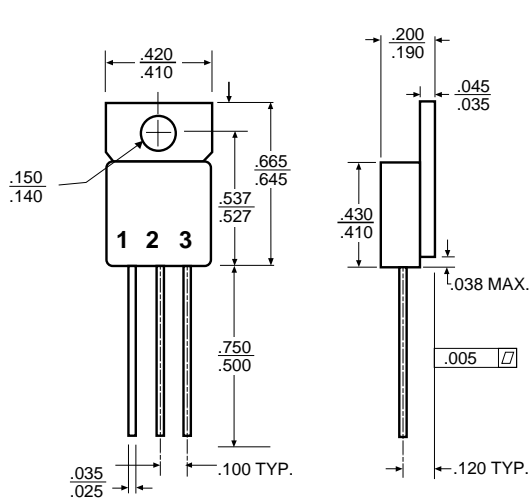

OM1326SMM

Front View
 Pin 1 - Adjust
 Pin 2 - Input
 Pin 3 - Output
 Case - Isolated

OM1326STM
 Isolated
 Front View
 Pin 1 - Adjust
 Pin 2 - Output
 Pin 3 - Input
 Tab - Isolated

OM1326NTM
 Non-Isolated
 Front View
 Pin 1 - Adjust
 Pin 2 - Output
 Pin 3 - Input
 Tab - Output

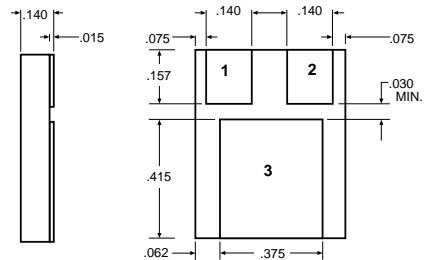

OM1326NMM

Pin 1 - Adjust
 Pin 2 - Input
 Pin 3 - Output

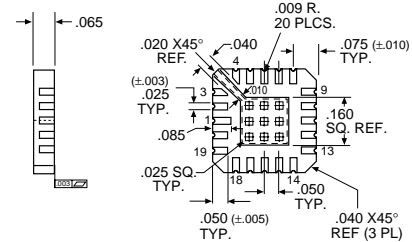
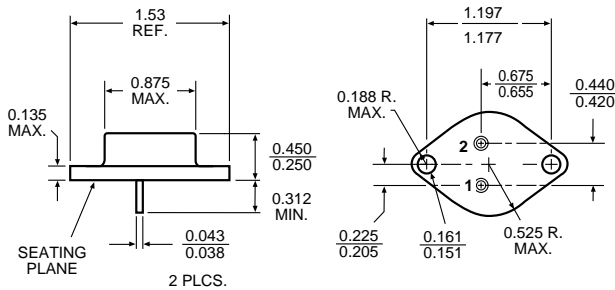

OM1326N2M

Pin 1 NC	Pin 11 V _{IN}
Pin 2 NC	Pin 12 V _{OUT}
Pin 3 NC	Pin 13 V _{OUT}
Pin 4 NC	Pin 14 V _{OUT} (Sense)
Pin 5 NC	Pin 15 NC
Pin 6 NC	Pin 16 NC
Pin 7 NC	Pin 17 NC
Pin 8 NC	Pin 18 ADJUST
Pin 9 NC	Pin 19 NC
Pin 10 NC	Pin 20 V _{IN}

3.5

OM1326NKM
 Pin 1 - Adjust
 Pin 2 - Input
 Case - Output

For additional information please see the mechanical outline section.