

Technical Document

- [Tools Information](#)
- [FAQs](#)
- [Application Note](#)

Features

- Operating voltage: 2.4V~5.0V
- Operating frequency: 3.58MHz~12MHz (typ. 11.059MHz)
- 28 bidirectional I/O lines
- Two 16-bit programmable timer/event counters with overflow interrupts
- Watchdog Timer
- Built-in 8-bit MCU with 208×8 bits RAM
- Built-in 64K×16-bit ROM for program/data shared
- Digital output pins for external DAC
- Single data format with 16 bits digital stereo audio output
- Two High D/A converter resolution: 16 bits
- Polyphonic up to 16 notes
- Independent pan and volume mix can be assigned to each sound component
- Sampling rate of 44.1kHz as 11.059MHz for system frequency
- Eight-level subroutine nesting
- HALT function and wake-up feature to reduce power consumption
- Bit manipulation instructions
- 16-bit table read instructions
- 63 powerful instructions
- All instructions in 1 or 2 machine cycles
- 48-pin SSOP package

General Description

The HT36B4 is an 8-bit high performance RISC-like microcontroller specifically designed for music applications. It provides an 8-bit MCU and a 16 channel wavetable synthesizer. The program ROM is composed of both program control codes and wavetable voice codes, and can be easily programmed.

The HT36B4 has a built-in 8-bit microprocessor which programs the synthesizer to generate the melody by setting the special register from 20H~2AH. A HALT feature is provided to reduce power consumption.

Block Diagram

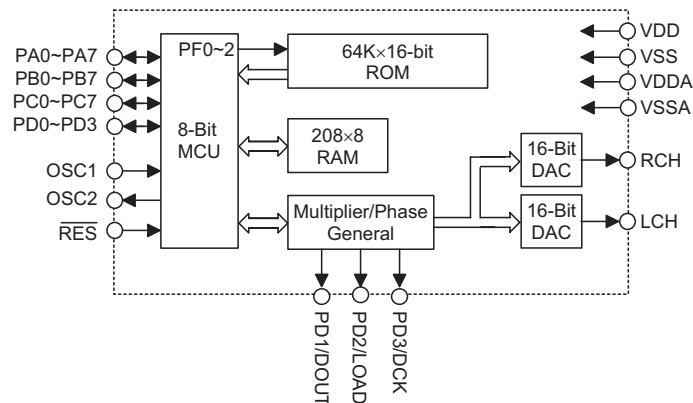

Pin Assignment

NC	1	48	NC
OSC1	2	47	OSC2
VSS	3	46	VDDA
VSS	4	45	LCH
VDD	5	44	RCH
NC	6	43	VSSA
NC	7	42	NC
PA0	8	41	RES
PA1	9	40	PD3
PA2	10	39	PD2
PA3	11	38	PD1
PA4	12	37	PD0
PA5	13	36	PC7
PA6	14	35	PC6
PA7	15	34	PC5
PB0	16	33	PC4
PB1	17	32	NC
NC	18	31	NC
PB2	19	30	PC3
PB3	20	29	PC2
PB4	21	28	PC1
PB5	22	27	PC0
PB6	23	26	PB7
NC	24	25	NC

HT36B4
- 48 SSOP-A

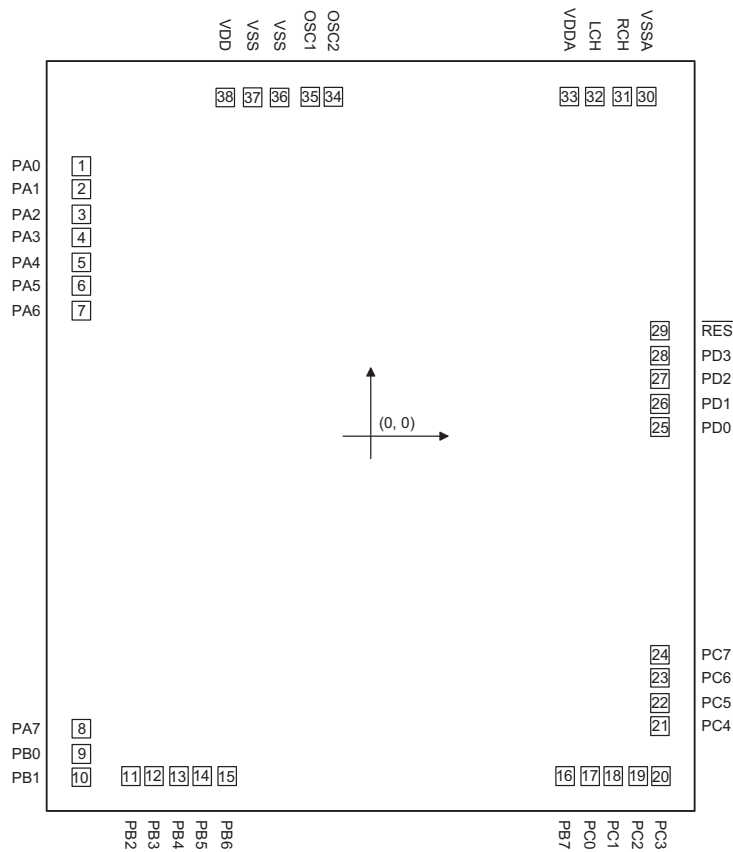
Pad Assignment

Chip size: 2690 × 3095 (μm)²

* The IC substrate should be connected to VSS in the PCB layout artwork.

Pad Coordinates

 Unit: μm

Pad No.	X	Y	Pad No.	X	Y
1	-1194.900	1108.540	20	1198.360	-1396.900
2	-1194.900	1013.540	21	1194.200	-1191.950
3	-1194.900	910.540	22	1194.200	-1096.950
4	-1194.900	815.540	23	1194.200	-993.950
5	-1194.900	712.540	24	1194.200	-898.950
6	-1194.900	617.540	25	1194.200	36.550
7	-1194.900	514.540	26	1194.200	131.550
8	-1194.900	-1203.060	27	1194.200	234.550
9	-1194.900	-1306.060	28	1194.200	329.550
10	-1194.900	-1401.060	29	1194.200	432.550
11	-989.950	-1396.900	30	1138.475	1393.120
12	-894.950	-1396.900	31	1038.450	1393.120
13	-791.950	-1396.900	32	925.450	1393.120
14	-696.950	-1396.900	33	819.765	1393.120
15	-593.950	-1396.900	34	-154.540	1392.655
16	802.360	-1396.900	35	-249.540	1392.655
17	905.360	-1396.900	36	-376.070	1390.100
18	1000.360	-1396.900	37	-487.200	1390.600
19	1103.360	-1396.900	38	-601.535	1390.100

Pad Description

Pad No.	Pad Name	I/O	Internal Connection	Function
1~8	PA0~PA7	I/O	Pull-High or None	Bidirectional 8-bit Input/Output port, wake-up by mask option
9~16, 17~24, 25	PB0~PB7, PC0~PC7, PD0	I/O	Pull-High or None	Bidirectional 8-bit Input/Output port
26	PD1/DOUT	I/O	Pull-High or None	Bidirectional 8-bit Input/Output port $\overline{\text{DAC}}$ data out
27	PD2/LOAD	I/O	Pull-High or None	Bidirectional 8-bit Input/Output port $\overline{\text{DAC}}$ word clock
28	PD3/DCK	I/O	Pull-High or None	Bidirectional 8-bit Input/Output port $\overline{\text{DAC}}$ bit clock
29	$\overline{\text{RES}}$	I	—	Reset input, active low
30	VSSA	—	—	Negative power supply of DAC, ground
31	RCH	O	CMOS	R channel audio output
32	LCH	O	CMOS	L channel audio output
33	VDDA	—	—	DAC power supply
35 34	OSC1 OSC2	I O	—	OSC1 and OSC2 are connected to an RC network or a crystal (by mask option) for the internal system clock. In the case of RC operation, OSC2 is the output terminal for 1/4 system clock ($f_{\text{OSC2}}=f_{\text{OSC}}/8$). The system clock may come from the crystal, the two pins cannot be floating.
36, 37	VSS	—	—	Negative power supply, ground
38	VDD	—	—	Positive power supply

Absolute Maximum Ratings

Supply Voltage	$V_{SS}-0.3V$ to $V_{SS}+6V$	Storage Temperature	$-50^{\circ}C$ to $125^{\circ}C$
Input Voltage	$V_{SS}-0.3V$ to $V_{DD}+0.3V$	Operating Temperature	$-40^{\circ}C$ to $85^{\circ}C$

Note: These are stress ratings only. Stresses exceeding the range specified under "Absolute Maximum Ratings" may cause substantial damage to the device. Functional operation of this device at other conditions beyond those listed in the specification is not implied and prolonged exposure to extreme conditions may affect device reliability.

D.C. Characteristics

Ta=25°C

Symbol	Parameter	Test Conditions		Min.	Typ.	Max.	Unit
		V _{DD}	Conditions				
V _{DD}	Operating Voltage	—	—	2.4	3	5	V
I _{DD}	Operating Current	5V	No load, f _{OSC} =11.0592MHz	—	8	16	mA
I _{STB}	Standby Current (WDT Disabled)	5V	No load, System HALT	—	0	—	μA
I _{OL}	I/O Ports Sink Current	5V	V _{OL} =0.5V	9.7	16.2	—	mA
I _{OH}	I/O Ports Source Current	5V	V _{OH} =4.5V	-5.2	-8.7	—	mA
R _{PH}	Pull-High Resistance of I/O Ports	5V	V _{IL} =0V	11	22	44	kΩ
V _{IH1}	Input High Voltage for I/O Ports	5V	—	3.5	—	5	V
V _{IL1}	Input Low Voltage for I/O Ports	5V	—	0	—	1.5	V
V _{IH2}	Input High Voltage (\overline{RES})	5V	—	—	4	—	V
V _{IL2}	Input Low Voltage (\overline{RES})	5V	—	—	2.5	—	V

A.C. Characteristics

Ta=25°C

Symbol	Parameter	Test Conditions		Min.	Typ.	Max.	Unit
		V _{DD}	Conditions				
MCU interface							
f _{OSC}	System Frequency	5V	12MHz crystal	—	12	—	MHz
f _{SYS}	System Clock	5V	—	4	—	16	MHz
t _{WDT}	Watchdog Time-Out Period (RC)	—	Without WDT prescaler	9	17	35	ms
t _{RES}	External Reset Low Pulse Width	—	—	1	—	—	μs

Symbol	Parameter	Figure	Min.	Typ.	Max.	Unit
DAC interface						
f _{BC}	DCK Bit Clock Frequency	Fig 1	—	f _{SYS} /16	—	MHz
t _{CH}	DCK Bit Clock H Level Time	Fig 1	600	—	—	ns
t _{DOS}	Data Output Setup Time	Fig 1	200	—	—	ns
t _{DOH}	Data Output Hold Time	Fig 1	200	—	—	ns
t _{LCS}	Load Clock Setup Time	Fig 1	200	—	—	ns
t _{LCH}	Load Clock Hold Time	Fig 1	200	—	—	ns

Characteristics Curves

V vs F Characteristics Curve

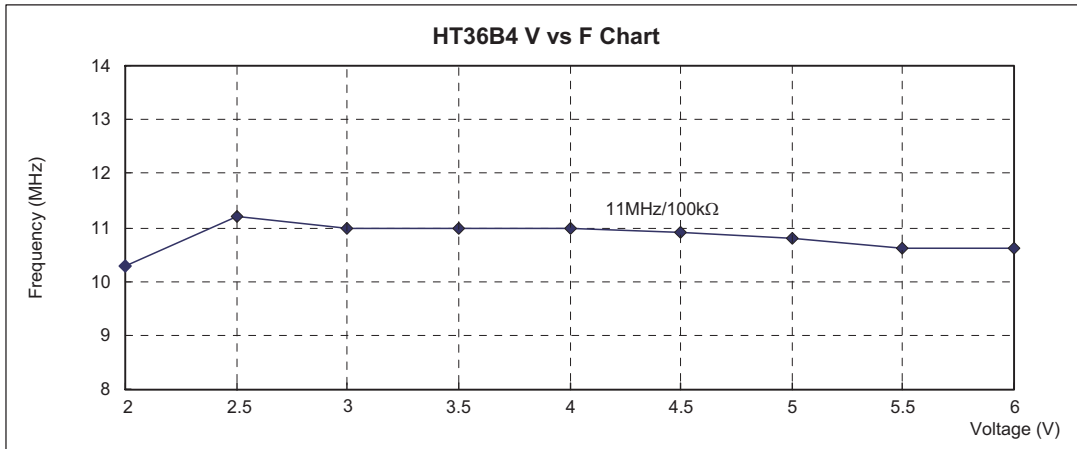

R vs F Characteristics curve

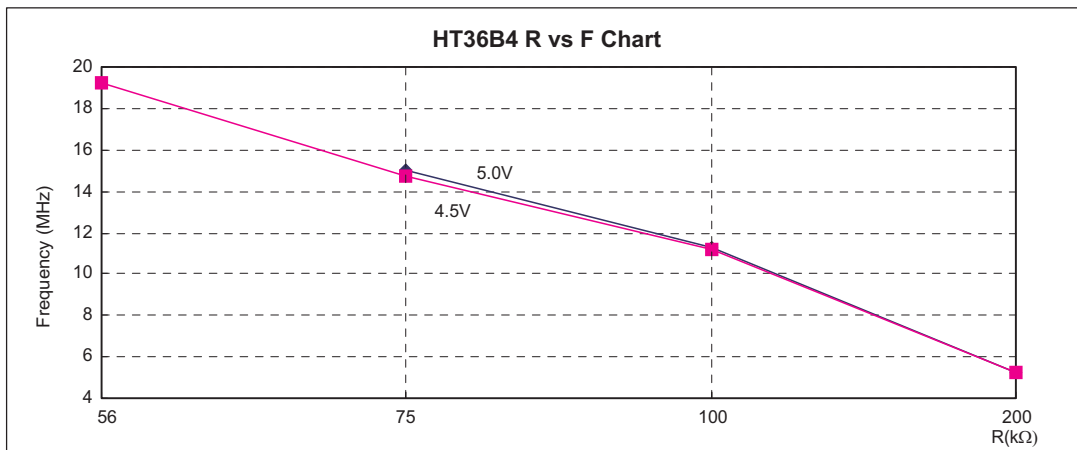

Function Description

Execution Flow

The system clock for the HT36B4 is derived from either a crystal or an RC oscillator. The oscillator frequency divided by 2 is the system clock for the MCU ($f_{osc}=f_{sys}\times 2$) and it is internally divided into four non-overlapping clocks. One instruction cycle consists of four system clock cycles.

Instruction fetching and execution are pipelined in such a way that a fetch takes one instruction cycle while decoding and execution takes the next instruction cycle. However, the pipelining scheme causes each instruction to effectively execute in one cycle. If an instruction changes the program counter, two cycles are required to complete the instruction.

Program Counter – PC

The 13-bit program counter (PC) controls the sequence in which the instructions stored in program ROM are executed and its contents specify a maximum of 8192 addresses for each bank.

After accessing a program memory word to fetch an instruction code, the contents of the program counter are incremented by one. The program counter then points to the memory word containing the next instruction code.

When executing a jump instruction, conditional skip execution, loading PCL register, subroutine call, initial reset, internal interrupt, external interrupt or return from subroutine, the PC manipulates the program transfer by loading the address corresponding to each instruction.

The conditional skip is activated by instruction. Once the condition is met, the next instruction, fetched during the current instruction execution, is discarded and a dummy cycle replaces it to retrieve the proper instruction. Otherwise proceed with the next instruction.

The lower byte of the program counter (PCL) is a readable and writeable register (06H). Moving data into the PCL performs a short jump. The destination will be within 256 locations.

Once a control transfer takes place, an additional dummy cycle is required.

Program ROM

HT36B4 provides 16 address lines WA15~0 to read the Program ROM which is up to 1M bits, and is commonly used for the wavetable voice codes and the program memory. It provides two address types, one type is for program ROM, which is addressed by a bank pointer PF2~0 and a 13-bit program counter 12~0; and the other type is for wavetable code, which is addressed by

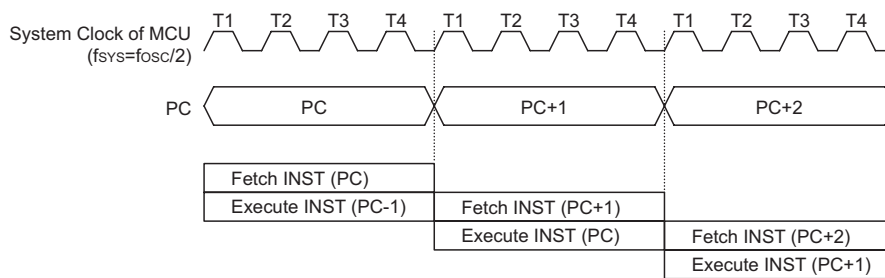

Execution Flow

Mode	Program Counter															
	*15	*14	*13	*12	*11	*10	*9	*8	*7	*6	*5	*4	*3	*2	*1	*0
Initial Reset	0	0	0	0	0	0	0	0	0	0	0	0	0	0	0	0
Timer/Event Counter 0 Overflow	0	0	0	0	0	0	0	0	0	0	0	0	1	0	0	0
Timer/Event Counter 1 Overflow	0	0	0	0	0	0	0	0	0	0	0	0	1	1	0	0
Skip	Program Counter + 2															
Loading PCL	PF2	PF1	PF0	*12	*11	*10	*9	*8	@7	@6	@5	@4	@3	@2	@1	@0
Jump, Call Branch	PF2	PF1	PF0	#12	#11	#10	#9	#8	#7	#6	#5	#4	#3	#2	#1	#0
Return From Subroutine	PF2	PF1	PF0	S12	S11	S10	S9	S8	S7	S6	S5	S4	S3	S2	S1	S0

Program Counter

Note: *12~*0: Bits of Program Counter
 #12~#0: Bits of Instruction Code
 @7~@0: Bits of PCL

@7~@0: Bits of PCL
 S12~S0: Bits of Stack Register
 PF2~PF0: Bits of Bank Register

Wavetable ROM

The ST11~0 is used to defined the start address of each sample on the wavetable and read the waveform data from the location. HT36B4 provides 21 output address lines from WA16~0, the ST11~0 is used to locate the major 16 bits i.e. WA16~5 and the undefined data from WA4~0 is always set to 00000b. So the start address of each sample have to be located at a multiple of 32. Otherwise, the sample will not be read out correctly because it has a wrong starting code.

Stack Register – Stack

This is a special part of the memory which is used to save the contents of the program counter (PC) only. The stack is organized into 8 levels and is neither part of the data nor part of the program space, and is neither readable nor writeable. The activated level is indexed by the stack pointer (SP) and is neither readable nor writeable. At a subroutine call or interrupt acknowledgment, the contents of the program counter are pushed onto the stack. At the end of a subroutine or an interrupt routine, signaled by a return instruction (RET or RETI), the program counter is restored to its previous value from the stack. After a chip reset, the SP will point to the top of the stack.

If the stack is full and a non-masked interrupt takes place, the interrupt request flag will be recorded but the acknowledgment will be inhibited. When the stack pointer is decremented (by RET or RETI), the interrupt will be serviced. This feature prevents stack overflow allowing the programmer to use the structure more easily. In a similar case, if the stack is full and a CALL is subsequently executed, a stack overflow occurs and the first entry will be lost (only the most recent eight return address are stored).

Data Memory – RAM

The data memory is designed with 256x8 bits. The data memory is divided into three functional groups: special function registers, wavetable function register, and general purpose data memory (208x8). Most of them are read/write, but some are read only.

The unused space before 30H is reserved for future expanded usage and reading these locations will return the result 00H. The general purpose data memory, addressed from 30H to FFH, is used for data and control information under instruction command.

All data memory areas can handle arithmetic, logic, increment, decrement and rotate operations directly. Except for some dedicated bits, each bit in the data memory can be set and reset by the SET [m].i and CLR [m].i instructions, respectively. They are also indirectly accessible through Memory pointer registers (MP0;01H, MP1;03H).

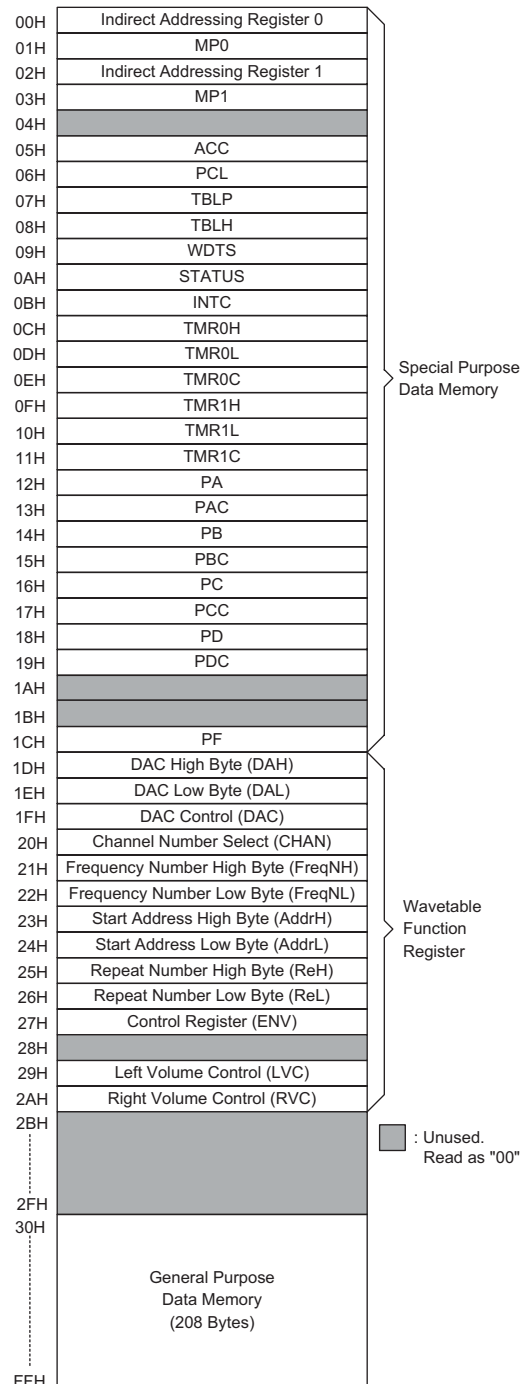

RAM Mapping

Indirect Addressing Register

Location 00H and 02H are indirect addressing registers that are not physically implemented. Any read/write operation of [00H] and [02H] access data memory pointed to by MP0 (01H) and MP1 (03H) respectively. Reading location 00H or 02H directly will return the result 00H. And writing directly results in no operation.

The function of data movement between two indirect addressing registers, is not supported. The memory pointer registers, MP0 and MP1, are 8-bit register which can be used to access the data memory by combining corresponding indirect addressing registers.

Accumulator

The accumulator closely relates to ALU operations. It is mapped to location 05H of the data memory and it can operate with immediate data. The data movement between two data memory locations must pass through the accumulator.

Arithmetic and Logic Unit – ALU

This circuit performs 8-bit arithmetic and logic operation. The ALU provides the following functions:

- Arithmetic operations (ADD, ADC, SUB, SBC, DAA)
- Logic operations (AND, OR, XOR, CPL)
- Rotation (RL, RR, RLC, RRC)
- Increment & Decrement (INC, DEC)
- Branch decision (SZ, SNZ, SIZ, SDZ)

The ALU not only saves the results of a data operation but can also change the status register.

Status Register – STATUS

This 8-bit register (0AH) contains the zero flag (Z), carry flag (C), auxiliary carry flag (AC), overflow flag (OV), power down flag (PDF) and Watchdog time-out flag (TO). It also records the status information and controls the operation sequence.

With the exception of the TO and PDF flags, bits in the status register can be altered by instructions like any other register. Any data written into the status register will not change the TO or PDF flags. In addition it should be noted that operations related to the status register may give different results from those intended. The TO and PDF flags can only be changed by system power

up, Watchdog Timer overflow, executing the HALT instruction and clearing the Watchdog Timer.

The Z, OV, AC and C flags generally reflect the status of the latest operations.

In addition, on entering the interrupt sequence or executing a subroutine call, the status register will not be automatically pushed onto the stack. If the contents of status are important and the subroutine can corrupt the status register, the programmer must take precautions to save it properly.

Interrupt

The HT36B4 provides two internal timer/event counter interrupts on each bank. The Interrupt Control register (INTC;0BH) contains the interrupt control bits that sets the enable/disable and the interrupt request flags.

Once an interrupt subroutine is serviced, all other interrupts will be blocked (by clearing the EMI bit). This scheme may prevent any further interrupt nesting. Other interrupt requests may occur during this interval but only the interrupt request flag is recorded. If a certain interrupt needs servicing within the service routine, the programmer may set the EMI bit and the corresponding bit of the INTC to allow interrupt nesting. If the stack is full, the interrupt request will not be acknowledged, even if the related interrupt is enabled, until the SP is decremented. If immediate service is desired, the stack must be prevented from becoming full.

All these kinds of interrupt have a wake-up capability. As an interrupt is serviced, a control transfer occurs by pushing the program counter onto the stack and then branching to subroutines at specified locations in the program memory. Only the program counter is pushed onto the stack. If the contents of the register and Status register (STATUS) are altered by the interrupt service program which may corrupt the desired control sequence, then the programmer must save the contents first.

Bit No.	Label	Function
0	C	C is set if an operation results in a carry during an addition operation or if a borrow does not take place during a subtraction operation; otherwise C is cleared. Also it is affected by a rotate through carry instruction.
1	AC	AC is set if an operation results in a carry out of the low nibbles in addition or no borrow from the high nibble into the low nibble in subtraction; otherwise AC is cleared.
2	Z	Z is set if the result of an arithmetic or logical operation is zero; otherwise Z is cleared.
3	OV	OV is set if an operation results in a carry into the highest-order bit but not a carry out of the highest-order bit, or vice versa; otherwise OV is cleared.
4	PDF	PDF is cleared by either a system power-up or executing the CLR WDT instruction. PDF is set by executing the HALT instruction.
5	TO	TO is cleared by a system power-up or executing the CLR WDT or HALT instruction. TO is set by a WDT time-out.
6~7	—	Unused bit, read as "0"

STATUS (0AH) Register

The internal Timer/Event Counter 0 interrupt is initialized by setting the Timer/Event Counter 0 interrupt request flag (T0F; bit 5 of INTC), caused by a Timer/Event Counter 0 overflow. When the interrupt is enabled, and the stack is not full and the T0F bit is set, a subroutine call to location 08H will occur. The related interrupt request flag (T0F) will be reset and the EMI bit cleared to disable further interrupts.

The Timer/Event Counter 1 interrupt is operated in the same manner as Timer/Event Counter 0. The related interrupt control bits ET1I and T1F of the Timer/Event Counter 1 are bit 3 and bit 6 of the INTC respectively.

During the execution of an interrupt subroutine, other interrupt acknowledgments are held until the RETI instruction is executed or the EMI bit and the related interrupt control bit are set to 1 (if the stack is not full). To return from the interrupt subroutine, the RET or RETI instruction may be invoked. RETI will set the EMI bit to enable an interrupt service, but RET will not.

Interrupts occurring in the interval between the rising edges of two consecutive T2 pulses, will be serviced on the latter of the two T2 pulses, if the corresponding interrupts are enabled. In the case of simultaneous requests the priorities in the following table apply. These can be masked by resetting the EMI bit.

Interrupt Source	Priority	Vector
Timer/event Counter 0 overflow	1	08H
Timer/event Counter 1 overflow	2	0CH

Once the interrupt request flags (T0F, T1F) are set, they will remain in the INTC register until the interrupts are serviced or cleared by a software instruction. It is recommended that a program does not use the "CALL subroutine" within the interrupt subroutine. Because interrupts often occur in an unpredictable manner or need to be serviced immediately in some applications, if only one stack is left and enabling the interrupt is not well controlled, once the "CALL subroutine" operates in the interrupt subroutine, it may damage the original control sequence.

Bit No.	Label	Function
0	EMI	Controls the Master (Global) interrupt (1=enabled; 0=disabled)
1	—	Unused bit, read as "0"
2	ET0I	Controls the Timer/Event Counter 0 interrupt (1=enabled; 0=disabled)
3	ET1I	Controls the Timer/Event Counter 1 interrupt (1=enabled; 0=disabled)
4	—	Unused bit, read as "0"
5	T0F	Internal Timer/Event Counter 0 request flag (1=active; 0=inactive)
6	T1F	Internal Timer/Event Counter 1 request flag (1=active; 0=inactive)
7	—	Unused bit, read as "0"

INTC (OBH) Register

Oscillator Configuration

The HT36B4 provides two types of oscillator circuit for the system clock, i.e., RC oscillator and crystal oscillator. No matter what type of oscillator, the signal divided by 2 is used for the system clock. The HALT mode stops the system oscillator and ignores external signal to conserve power. If the RC oscillator is used, an external resistor between OSC1 and VSS is required, and the range of the resistance should be from 56kΩ to 680kΩ. The system clock, divided by 4, is available on OSC2 with pull-high resistor, which can be used to synchronize external logic. The RC oscillator provides the most cost effective solution. However, the frequency of the oscillation may vary with VDD, temperature, and the chip itself due to process variations. It is therefore, not suitable for timing sensitive operations where accurate oscillator frequency is desired.

On the other hand, if the crystal oscillator is selected, a crystal across OSC1 and OSC2 is needed to provide the feedback and phase shift required for the oscillator, and no other external components are required. A resonator may be connected between OSC1 and OSC2 to replace the crystal and to get a frequency reference, but two external capacitors in OSC1 and OSC2 are required.

The WDT oscillator is a free running on-chip RC oscillator, and no external components are required. Even if the system enters the power down mode, the system clock is stopped, but the WDT oscillator still works with a period of approximately 78μs. The WDT oscillator can be disabled by mask option to conserve power.

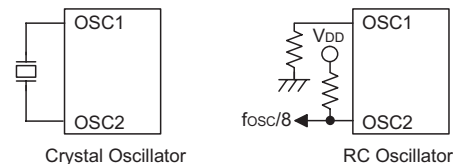

System Oscillator

Watchdog Timer – WDT

The WDT clock source is implemented by a dedicated RC oscillator (WDT oscillator) or instruction clock (system clock of the MCU divided by 4), determined by mask options. This timer is designed to prevent a software malfunction or sequence jumping to an unknown location with unpredictable results. The Watchdog Timer can be disabled by mask option. If the Watchdog Timer is disabled, all the executions related to the WDT result in no operation.

Once the internal WDT oscillator (RC oscillator with a period of 78µs normally) is selected, it is first divided by 256 (8-stages) to get the nominal time-out period of approximately 20ms. This time-out period may vary with temperature, VDD and process variations. By invoking the WDT prescaler, longer time-out periods can be realized. Writing data to WS2, WS1, WS0 (bit 2,1,0 of the WDTS) can give different time-out periods. If WS2, WS1, WS0 all equal to 1, the division ratio is up to 1:128, and the maximum time-out period is 2.6 seconds.

If the WDT oscillator is disabled, the WDT clock may still come from the instruction clock and operate in the same manner except that in the HALT state the WDT may stop counting and lose its protecting purpose. In this situation the logic can only be restarted by external logic. The high nibble and bit 3 of the WDTS are reserved for user defined flags, and the programmer may use these flags to indicate some specified status.

WS2	WS1	WS0	Division Ratio
0	0	0	1:1
0	0	1	1:2
0	1	0	1:4
0	1	1	1:8
1	0	0	1:16
1	0	1	1:32
1	1	0	1:64
1	1	1	1:128

If the device operates in a noisy environment, using the on-chip RC oscillator (WDT OSC) is strongly recommended, since the HALT will stop the system clock.

The WDT overflow under normal operation will initialize

a "chip reset" and set the status bit TO. Whereas in the HALT mode, the overflow will initialize a "warm reset" only the program counter and SP are reset to zero. To clear the WDT contents (including the WDT prescaler), 3 methods are implemented; external reset (a low level to \overline{RES}), software instructions, or a HALT instruction. The software instructions include CLR WDT and the other set – CLR WDT1 and CLR WDT2. Of these two types of instructions, only one can be active depending on the mask option – "CLR WDT times selection option". If the "CLR WDT" is selected (i.e. CLRWDT times equal one), any execution of the CLR WDT instruction will clear the WDT. In case "CLR WDT1" and "CLR WDT2" are chosen (i.e. CLRWDT times equal two), these two instructions must be executed to clear the WDT; otherwise, the WDT may reset the chip because of time-out.

Power Down Operation – HALT

The HALT mode is initialized by a HALT instruction and results in the following...

- The system oscillator will turn off but the WDT oscillator keeps running (If the WDT oscillator is selected). Watchdog Timer – WDT
- The contents of the on-chip RAM and registers remain unchanged
- The WDT and WDT prescaler will be cleared and starts to count again (if the clock comes from the WDT oscillator).
- All I/O ports maintain their original status.
- The PDF flag is set and the TO flag is cleared.
- The HALT pin will output a high level signal to disable the external ROM.

The system can leave the HALT mode by means of an external reset, an interrupt, an external falling edge signal on port A or a WDT overflow. An external reset causes a device initialization and the WDT overflow performs a "warm reset". By examining the TO and PDF flags, the cause for a chip reset can be determined. The PDF flag is cleared when there is a system power-up or by executing the CLR WDT instruction and it is set when a HALT instruction is executed. The TO flag is set if the WDT time-out occurs, and causes a wake-up that only resets the program counter and stack pointer, the others remain in their original status.

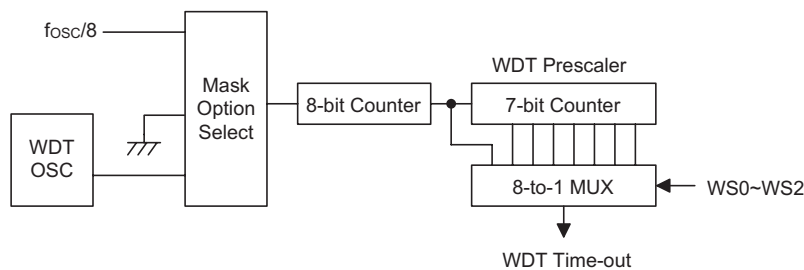

Watchdog Timer

The port A wake-up and interrupt methods can be considered as a continuation of normal execution. Each bit in port A can be independently selected to wake-up the device by mask option. Awakening from an I/O port stimulus, the program will resume execution of the next instruction. If awakening from an interrupt, two sequences may occur. If the related interrupts is disabled or the interrupts is enabled but the stack is full, the program will resume execution at the next instruction. If the interrupt is enabled and the stack is not full, a regular interrupt response takes place.

Once a wake-up event occurs, it takes $1024 t_{SYS}$ (system clock period) to resume to normal operation. In other words, a dummy cycle period will be inserted after the wake-up. If the wake-up results from an interrupt acknowledge, the actual interrupt subroutine will be delayed by one more cycle. If the wake-up results in next instruction execution, this will execute immediately after a dummy period has finished. If an interrupt request flag is set to "1" before entering the HALT mode, the wake-up function of the related interrupt will be disabled.

To minimize power consumption, all I/O pins should be carefully managed before entering the HALT status.

Reset

There are 3 ways in which a reset can occur:

- \overline{RES} reset during normal operation
- \overline{RES} reset during HALT
- WDT time-out reset during normal operation

The WDT time-out during HALT is different from other chip reset conditions, since it can perform a "warm reset" that just resets the program counter and SP, leaving the other circuits to maintain their state. Some registers remain unchanged during any other reset conditions. Most registers are reset to the "initial condition" when the reset conditions are met. By examining the PDF and TO flags, the program can distinguish between different "chip resets".

TO	PDF	RESET Conditions
0	0	\overline{RES} reset during power-up
u	u	\overline{RES} reset during normal operation
0	1	\overline{RES} wake-up HALT
1	u	WDT time-out during normal operation
1	1	WDT wake-up HALT

Note: "u" stands for "unchanged"

To guarantee that the system oscillator has started and stabilized, the SST (System Start-up Timer) provides an extra-delay of 1024 system clock pulses during system power up or when the system awakes from a HALT state.

When a system power-up occurs, the SST delay is added during the reset period. But when the reset comes from the \overline{RES} pin, the SST delay is disabled. Any wake-up from HALT will enable the SST delay.

The functional units chip reset status are shown below.

Program Counter	000H
Interrupt	Disable
Prescaler	Clear
WDT	Clear. After master reset, WDT begins counting
Timer/Event Counter (0/1)	Off
Input/output ports	Input mode
Stack Pointer	Points to the top of stack

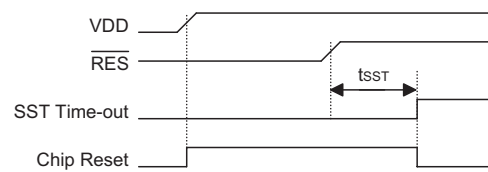

Reset Timing Chart

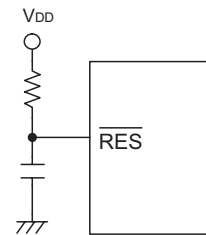

Reset Circuit

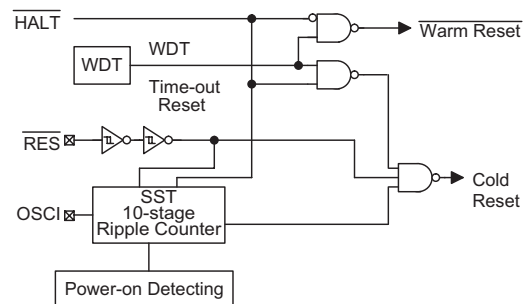

Reset Configuration

The registers status is summarized in the following table:

Register	Reset (Power On)	WDT Time-out (Normal Operation)	$\overline{\text{RES}}$ Reset (Normal Operation)	$\overline{\text{RES}}$ Reset (HALT)	WDT Time-out (HALT)*
MP0	xxxx xxxx	uuuu uuuu	uuuu uuuu	uuuu uuuu	uuuu uuuu
MP1	xxxx xxxx	uuuu uuuu	uuuu uuuu	uuuu uuuu	uuuu uuuu
ACC	xxxx xxxx	uuuu uuuu	uuuu uuuu	uuuu uuuu	uuuu uuuu
Program Counter	0000H	0000H	0000H	0000H	0000H
TBLP	xxxx xxxx	uuuu uuuu	uuuu uuuu	uuuu uuuu	uuuu uuuu
TBLH	xxxx xxxx	uuuu uuuu	uuuu uuuu	uuuu uuuu	uuuu uuuu
WDTS	0000 0111	0000 0111	0000 0111	0000 0111	uuuu uuuu
STATUS	--00 xxxx	--1u uuuu	--uu uuuu	--01 uuuu	--11 uuuu
INTC	-00- 00-0	-00- 00-0	-00- 00-0	-00- 00-0	-uu- uu-u
TMR0H	xx-x x---	xx-x x---	xx-x x---	xx-x x---	uu-u u---
TMR0L	xx-x x---	xx-x x---	xx-x x---	xx-x x---	uu-u u---
TMR0C	00-0 1000	00-0 1000	00-0 1000	00-0 1000	uu-u 1uuu
TMR1H	xx-x x---	xx-x x---	xx-x x---	xx-x x---	uu-u u---
TMR1L	xx-x x---	xx-x x---	xx-x x---	xx-x x---	uu-u u---
TMR1C	00-0 1000	00-0 1000	00-0 1000	00-0 1000	uu-u 1uuu
PA	1111 1111	1111 1111	1111 1111	1111 1111	uuuu uuuu
PAC	1111 1111	1111 1111	1111 1111	1111 1111	uuuu uuuu
PB	1111 1111	1111 1111	1111 1111	1111 1111	uuuu uuuu
PBC	1111 1111	1111 1111	1111 1111	1111 1111	uuuu uuuu
PC	1111 1111	1111 1111	1111 1111	1111 1111	uuuu uuuu
PCC	1111 1111	1111 1111	1111 1111	1111 1111	uuuu uuuu
PD	---- 1111	---- 1111	---- 1111	---- 1111	---- uuuu
PDC	---- 1111	---- 1111	---- 1111	---- 1111	---- uuuu
PF	---- -000	---- -000	---- -000	---- -000	---- -uuu
DAH	xxxx xxxx	uuuu uuuu	uuuu uuuu	uuuu uuuu	uuuu uuuu
DAL	xxxx xxxx	uuuu uuuu	uuuu uuuu	uuuu uuuu	uuuu uuuu
DAC	---- -000	---- -000	---- -000	---- -000	---- -uuu
CHAN	00-- 0000	uu-- uuuu	uu-- uuuu	uu-- uuuu	uu-- uuuu
FreqNH	xxxx xxxx	uuuu uuuu	uuuu uuuu	uuuu uuuu	uuuu uuuu
FreqNL	xxxx xxxx	uuuu uuuu	uuuu uuuu	uuuu uuuu	uuuu uuuu
AddrH	xxxx xxxx	uuuu uuuu	uuuu uuuu	uuuu uuuu	uuuu uuuu
AddrL	xxxx xxxx	uuuu uuuu	uuuu uuuu	uuuu uuuu	uuuu uuuu
ReH	xxxx xxxx	uuuu uuuu	uuuu uuuu	uuuu uuuu	uuuu uuuu
ReL	xxxx xxxx	uuuu uuuu	uuuu uuuu	uuuu uuuu	uuuu uuuu
ENV	x-xx xxxx	u-uu uuuu	u-uu uuuu	u-uu uuuu	u-uu uuuu
LVC	xxxx xxxx	uuuu uuuu	uuuu uuuu	uuuu uuuu	uuuu uuuu
RVC	xxxx xxxx	uuuu uuuu	uuuu uuuu	uuuu uuuu	uuuu uuuu

Note: "*" stands for warm reset
 "u" stands for unchanged
 "x" stands for unknown

Timer/Event Counter

Two timer/event counters are implemented in the HT36B4. The Timer/Event Counter 0 and Timer/Event Counter 1 contain 16-bit programmable count-up counters and the clock comes from the system clock divided by 4.

There are three registers related to Timer/Event Counter 0; TMR0H (0CH), TMR0L (0DH), TMR0C (0EH). Writing TMR0L only writes the data into a low byte buffer, and writing TMR0H will write the data and the contents of the low byte buffer into the Timer/Event Counter 0 Preload register (16-bit) simultaneously. The Timer/Event Counter 0 Preload register is changed by writing TMR0H operations and writing TMR0L will keep the Timer/Event Counter 0 Preload register unchanged.

Reading TMR0H will also latch the TMR0L into the low byte buffer to avoid a false timing problem. Reading TMR0L returns the contents of the low byte buffer. In other words, the low byte of the Timer/Event Counter 0 cannot be read directly. It must read the TMR0H first to make the low byte contents of the Timer/Event Counter 0 latched into the buffer.

There are three registers related to the Timer/Event Counter 1; TMR1H (0FH), TMR1L (10H), TMR1C (11H). The Timer/Event Counter 1 operates in the same manner as Timer/Event Counter 0.

The TMR0C is the Timer/Event Counter 0 control register, which defines the Timer/Event Counter 0 options. The Timer/Event Counter 1 has the same options with Timer/Event Counter 0 and is defined by TMR1C.

The Timer/event Counter control registers define the operating mode, counting enable or disable and active edge.

The TM0, TM1 bits define the operating mode. The Event count mode is used to count external events, which means the clock source comes from an external (TMR) pin. The Timer mode functions as a normal timer with the clock source coming from the instruction clock. The pulse width measurement mode can be used to

count the high or low level duration of the external signal (TMR). The counting is based on the instruction clock.

In the Event count or Timer mode, once the timer/event counter starts counting, it will count from the current contents in the timer/event counter to FFFFH. Once overflow occurs, the counter is reloaded from the Timer/Event Counter Preload register and simultaneously generates the corresponding interrupt request flag (TOF/T1F; bit 5/6 of INTC).

In pulse width measurement mode with the TON and TE bits equal to one, once the TMR has received a transient from low to high (or high to low; if the TE bit is 0) it will start counting until the TMR returns to the original level and resets the TON. The measured result will remain in the even if the activated transient occurs again. In other words, only one cycle measurements can be done. Until setting the TON, the cycle measurement will function again as long as it receives further transient pulse. Note that, in this operating mode, the timer/event counter starts counting not according to the logic level but according to the transient edges. In the case of counter overflows, the counter is reloaded from the timer/event counter preload register and issues the interrupt request just like the other two modes.

To enable the counting operation, the Timer ON bit (TON; bit 4 of TMR0C/TMR1C) should be set to 1. In the pulse width measurement mode, the TON will be cleared automatically after the measurement cycle is completed. But in the other two modes the TON can only be reset by instruction. The overflow of the timer/event counter is one of the wake-up sources. No matter what the operation mode is, writing a 0 to ET0I/ET1I can disable the corresponding interrupt service.

In the case of timer/event counter OFF condition, writing data to the Timer/event Counter Preload register will also reload that data to the timer/event counter. But if the timer/event counter is turned on, data written to the timer/event counter will only be kept in the timer/event counter preload register. The timer/event counter will still operate until overflow occurs.

Bit No.	Label	Function
0~2	—	Unused bit, read as "0"
3	TE	Define the TMR active edge of Timer/Event Counter 0 (0=active on low to high; 1=active on high to low)
4	TON	Enable/disable timer counting (0=disable; 1=enable)
5	—	Unused bit, read as "0"
6 7	TM0 TM1	Defines the operating mode 01=Event count mode (External clock) 10=Timer mode (Internal clock) 11=Pulse width measurement mode 00=Unused

TMR0C(0EH) / TMR1C(11H) Register

When the timer/event counter (reading TMR0H/TMR1H) is read, the clock will be blocked to avoid errors. As this may result in a counting error, this must be taken into consideration by the programmer.

The two timer counters of HT36B4 are internal clock mode only, so only Timer mode can be selected. Therefore the (TM1, TM0) bits can only be set to (TM1, TM0) = (1, 0), and the other clock modes are invalid.

Input/Output Ports

There are 28 bidirectional input/output lines labeled from PA to PD, which are mapped to the data memory of [12H], [14H], [16H], [18H] respectively. All these I/O ports can be used for input and output operations. For input operation, these ports are non-latching, that is, the inputs must be ready at the T2 rising edge of instruction MOV A,[m] (m=12H, 14H, 16H or 18H). For output operation, all data is latched and remains unchanged until the output latch is rewritten.

Each I/O line has its own control register (PAC, PBC, PCC, PDC) to control the input/output configuration. With this control register, CMOS output or Schmitt Trigger input with or without pull-high resistor (mask option) structures can be reconfigured dynamically under soft-

ware control. To function as an input, the corresponding latch of the control register must write a "1". The pull-high resistance will exhibit automatically if the pull-high option is selected. The input source also depends on the control register. If the control register bit is "1", input will read the pad state. If the control register bit is "0", the contents of the latches will move to the internal bus. The latter is possible in "read-modify-write" instruction. For output function, CMOS is the only configuration. These control registers are mapped to locations 13H, 15H, 17H and 19H).

After a chip reset, these input/output lines remain at high levels or floating (mask option). Each bit of these input/output latches can be set or cleared by the SET [m].i or CLR [m].i (m=12H, 14H, 16H or 18H) instruction.

Some instructions first input data and then follow the output operations. For example, the SET [m].i, CLR [m].i, CPL [m] and CPLA [m] instructions read the entire port states into the CPU, execute the defined operations (bit-operation), and then write the results back to the latches or the accumulator.

Each line of port A has the capability to wake-up the device.

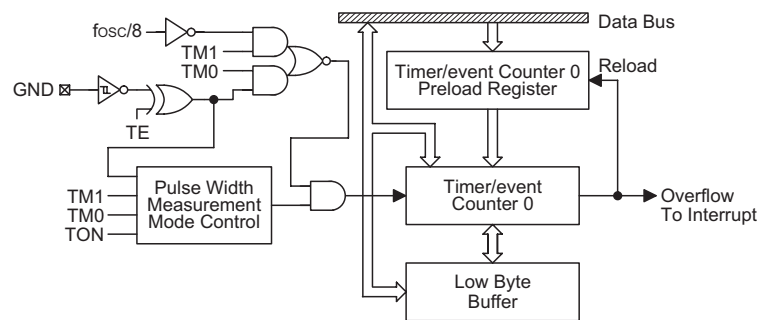

Timer/Event Counter 0/1

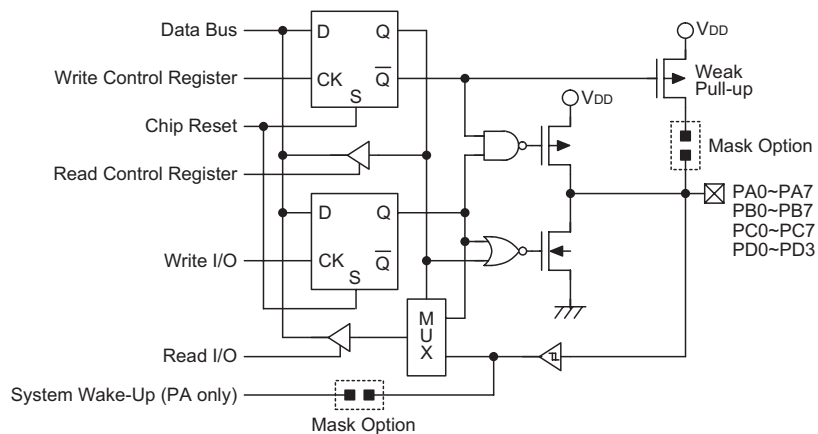

Input/Output Ports

16 Channel Wavetable Synthesizer

Wavetable Function Memory Mapping

Special Register for Wavetable Synthesizer								
RAM	B7	B6	B5	B4	B3	B2	B1	B0
20H	VM	FR	—	—	CH3	CH2	CH1	CH0
21H	BL3	BL2	BL1	BL0	FR11	FR10	FR9	FR8
22H	FR7	FR6	FR5	FR4	FR3	FR2	FR1	FR0
23H	ST15	ST14	ST13	ST12	ST11	ST10	ST9	ST8
24H	ST7	ST6	ST5	ST4	ST3	ST2	ST1	ST0
25H	WBS	RE14	RE13	RE12	RE11	RE10	RE9	RE8
26H	RE7	RE6	RE5	RE4	RE3	RE2	RE1	RE0
27H	A_R	—	VL9	VL8	ENV1	ENV0	VR9	VR8
29H	VL7	VL6	VL5	VL4	VL3	VL2	VL1	VL0
2AH	VR7	VR6	VR5	VR4	VR3	VR2	VR1	VR0

Wavetable Function Register Table

Register Name	Register Function	B7	B6	B5	B4	B3	B2	B1	B0
20H	Channel Number Selection					CH3	CH2	CH1	CH0
20H	Change Parameter Selection	VM	FR						
21H	Block Number Selection	BL3	BL2	BL1	BL0				
21H	Frequency Number Selection					FR11	FR10	FR9	FR8
22H		FR7	FR6	FR5	FR4	FR3	FR2	FR1	FR0
23H	Start Address Selection					ST11	ST10	ST9	ST8
24H		ST7	ST6	ST5	ST4	ST3	ST2	ST1	ST0
25H	Waveform Format Selection	WBS							
25H	Repeat Number Selection		RE14	RE13	RE12	RE11	RE10	RE9	RE8
26H		RE7	RE6	RE5	RE4	RE3	RE2	RE1	RE0
27H	Envelope Type Selection					ENV1	ENV0		
27H	Attach and Release Selection	A_R							
27H	Left Volume Controller			VL9	VL8				
29H		VL7	VL6	VL5	VL4	VL3	VL2	VL1	VL0
27H	Right Volume Controller							VR9	VR8
2AH		VR7	VR6	VR5	VR4	VR3	VR2	VR1	VR0

- CH3~0 channel number selection

The HT36B4 has a built-in 16 output channels and CH3~0 is used to define which channel is selected. When this register is written to, the wavetable synthesizer will automatically output the dedicated PCM code. So this register is also used as a start playing key and it has to be written to after all the other wavetable function registers are already defined.

- Change parameter selection

These two bits, VM and FR, are used to define which register will be updated on this selected channel. There are two modes that can be selected to reduce the process of setting the register. Please refer to the statements of the following table:

VM	FR	Function
0	0	Update all the parameter
0	1	Only update the frequency number
1	0	Only update the volume

- Output frequency definition

The data on BL3~0 and FR11~0 are used to define the output speed of the PCM file, i.e. it can be used to generate the tone scale. When the FR11~0 is 800H and BL3~0 is 6H, each sample data of the PCM code will be sent out sequentially.

When the f_{OSC} is 12.8MHz, the formula of a tone frequency is:

$$f_{OUT} = f_{RECORD} \times \frac{50kHz}{SR} \times \frac{FR11 \sim 0}{2^{(17-BL3 \sim 0)}}$$

where f_{OUT} is the output signal frequency, f_{RECORD} and SR is the frequency and sampling rate on the sample code, respectively.

So if a voice code of C3 has been recorded which has the f_{RECORD} of 261Hz and the SR of 11025Hz, the tone frequency (f_{OUT}) of G3: $f_{OUT}=196Hz$.

Can be obtained by using the formula:

$$196Hz = 261Hz \times \frac{50kHz}{11025Hz} \times \frac{FR11 \sim 0}{2^{(17-BL3 \sim 0)}}$$

A pair of the values FR11~0 and BL3~0 can be determined when the f_{OSC} is 12.8MHz.

- Start address definition

The HT36B4 provides two address types for extended use, one is the program ROM address which is program counter corresponding with PF value, the other is the start address of the PCM code.

The ST11~0 is used to define the start address of each PCM code and reads the waveform data from this location. The HT36B4 provides 16 input data lines from WA16~0, the ST11~0 is used to locate the major 16 bits i.e. WA16~5 and the undefined data from WA4~0 is always set as 00000b. In other words, the $WA16 \sim 0 = ST11 \sim 0 \times 2^5 \times 8$ bit. So each PCM code has to be located at a multiple of 32. Otherwise, the PCM code will not be read out correctly because it has a wrong start code.

- Waveform format definition

The HT36B4 accepts two waveform formats to ensure

a more economical data space. WBS is used to define the sample format of each PCM code.

- ♦ WBS=0 means the sample format is 8-bit

- ♦ WBS=1 means the sample format is 12-bit

The 12-bit sample format allocates location to each sample data. Please refer to the waveform format statement as shown below.

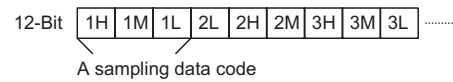
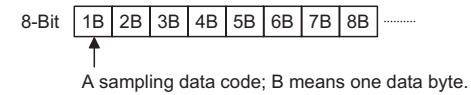

Note: "1H" High Nibble
 "1M" Middle Nibble
 "1L" Low Nibble

Waveform Format

- Repeat number definition

The repeat number is used to define the address which is the repeat point of the sample. When the repeat number is defined, it will be output from the start code to the end code once and always output the range between the repeat address to the end code (80H) until the volume become close.

The RE14~0 is used to calculate the repeat address of the PCM code. The process for setting the RE14~0 is to write the 2's complement of the repeat length to RE14~0, with the highest carry ignored. The HT36B4 will get the repeat address by adding the RE14~0 to the address of the end code, then jump to the address to repeat this range.

- Left and Right volume control

The HT36B4 provides the left and right volume control independently. The left and right volume are controlled by VL9~0 and VR9~0 respectively. The chip provides 1024 levels of controllable volume, the 000H is the maximum and 3FFH is the minimum output volume.

- Envelope type definition

The HT36B4 provides a function to easily program the envelope by setting the data of ENV1~0 and A_R. It forms a vibrato effect by a change of the volume to attach and release alternately.

The A_R signal is used to define the volume change in attach mode or release mode and ENV1~0 is used to define which volume control bit will be changeable. On the attach mode, the control bits will be sequentially signaled down to 0. On the release mode, the control bits will be sequentially signaled up to 1. The relationship is shown in the following table.

- The PCM code definition

The HT36B4 can only solve the voice format of the signed 8-bit raw PCM. And the MCU will take the voice code 80H as the end code.

So each PCM code section must be ended with the end code 80H.

A_R	ENV1	ENV0	Volume Control Bit	Control Bit Final Value	Mode
0	0	0	VL2~0, VR2~0	111b	Release mode
0	0	1	VL1~0, VR1~0	11b	
0	1	0	VL0, VR0	1b	
x	1	1	No Bit	unchanged	No change mode
1	0	0	VL2~0, VR2~0	000b	Attach mode
1	0	1	VL1~0, VR1~0	00b	
1	1	0	VL0, VR0	0b	

Envelope Type Definition

D/A Converter Interface

HT36B4 provides the IIS serial data format to support the multiple D/A converters, one bit clock output and a word clock signal for left/right stereo serial data transmission.

Clock Signal

The bit clock output signals DCK are used to synchronize the IIS serial data.

The word clock signal LOAD divides the serial data into left channel and right channel data for two-way audio output.

- **LOAD**
The word clock signal LOAD is used for IIS serial data. The stereo serial data consists of 16-channel sound generator.
- **DOUT**
On IIS format, a "H" state on LOAD is used for the right channel, and a "L" state is used for the left channel.
- **DCK**
DCK bit clock is the clock source for the signal.

Stereo Serial Data Format

The audio output data is in serial mode with 16 bit digital signal and LSB first output. There is a high sampling rate of 50kHz when the system clock is 12.8MHz and with two channel outputs for Right/Left channel. HT36B4 provides only one serial data format as IIS mode. The user could directly connect a D/A converter which can accept the IIS serial data format, like HT82V731.

Mask Option

No.	Mask Option	Function
1	WDT source	On-chip RC/Instruction clock/disable WDT
2	CLRWDT times	One time, two times (CLR WDT1/WDT2)
3	Wake-up	PA only
4	Pull-High	PA, PB, PC, PD input
5	OSC mode	Crystal or Resistor type
6	I/O DAC pin	PD1~3 DAC pin selection

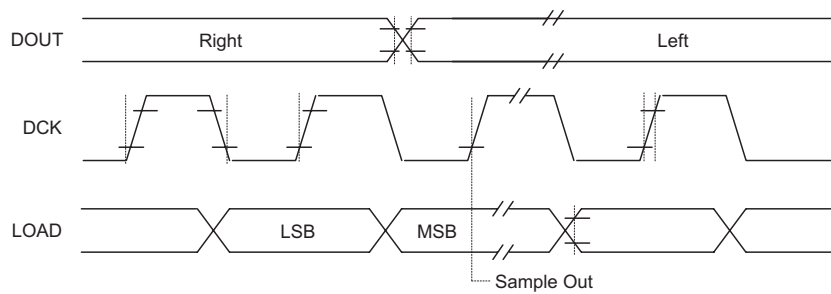

D/A Converter Timing

Application Circuit

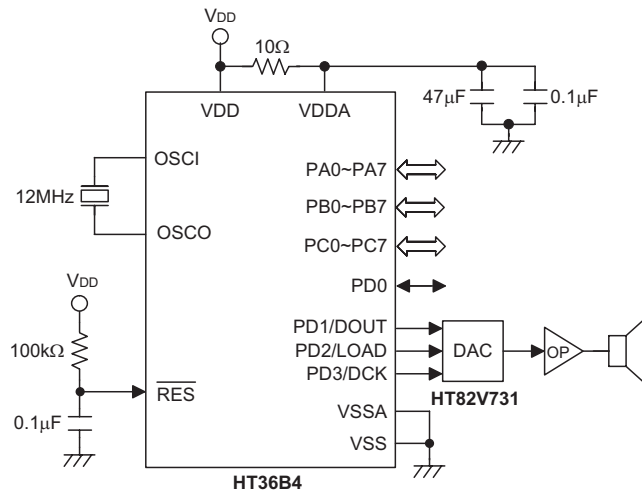
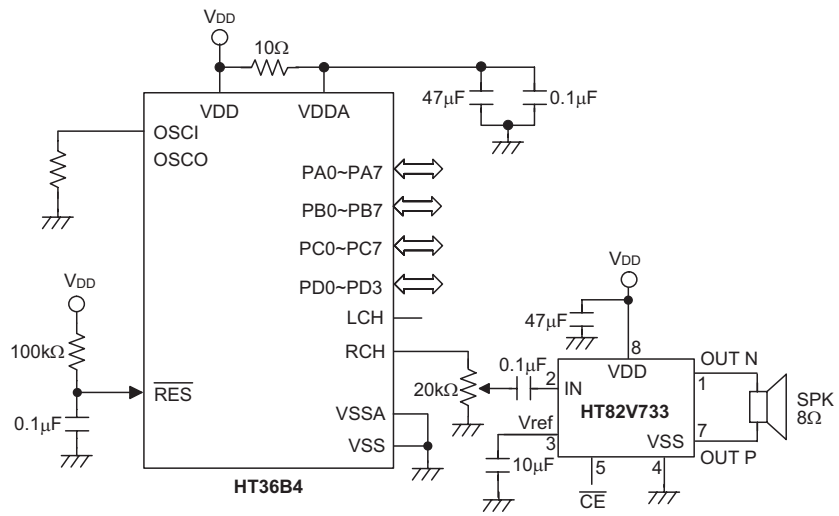

Instruction Set Summary

Mnemonic	Description	Instruction Cycle	Flag Affected
Arithmetic			
ADD A,[m]	Add data memory to ACC	1	Z,C,AC,OV
ADDM A,[m]	Add ACC to data memory	1 ⁽¹⁾	Z,C,AC,OV
ADD A,x	Add immediate data to ACC	1	Z,C,AC,OV
ADC A,[m]	Add data memory to ACC with carry	1	Z,C,AC,OV
ADCM A,[m]	Add ACC to data memory with carry	1 ⁽¹⁾	Z,C,AC,OV
SUB A,x	Subtract immediate data from ACC	1	Z,C,AC,OV
SUB A,[m]	Subtract data memory from ACC	1	Z,C,AC,OV
SUBM A,[m]	Subtract data memory from ACC with result in data memory	1 ⁽¹⁾	Z,C,AC,OV
SBC A,[m]	Subtract data memory from ACC with carry	1	Z,C,AC,OV
SBCM A,[m]	Subtract data memory from ACC with carry and result in data memory	1 ⁽¹⁾	Z,C,AC,OV
DAA [m]	Decimal adjust ACC for addition with result in data memory	1 ⁽¹⁾	C
Logic Operation			
AND A,[m]	AND data memory to ACC	1	Z
OR A,[m]	OR data memory to ACC	1	Z
XOR A,[m]	Exclusive-OR data memory to ACC	1	Z
ANDM A,[m]	AND ACC to data memory	1 ⁽¹⁾	Z
ORM A,[m]	OR ACC to data memory	1 ⁽¹⁾	Z
XORM A,[m]	Exclusive-OR ACC to data memory	1 ⁽¹⁾	Z
AND A,x	AND immediate data to ACC	1	Z
OR A,x	OR immediate data to ACC	1	Z
XOR A,x	Exclusive-OR immediate data to ACC	1	Z
CPL [m]	Complement data memory	1 ⁽¹⁾	Z
CPLA [m]	Complement data memory with result in ACC	1	Z
Increment & Decrement			
INCA [m]	Increment data memory with result in ACC	1	Z
INC [m]	Increment data memory	1 ⁽¹⁾	Z
DECA [m]	Decrement data memory with result in ACC	1	Z
DEC [m]	Decrement data memory	1 ⁽¹⁾	Z
Rotate			
RRA [m]	Rotate data memory right with result in ACC	1	None
RR [m]	Rotate data memory right	1 ⁽¹⁾	None
RRCA [m]	Rotate data memory right through carry with result in ACC	1	C
RRC [m]	Rotate data memory right through carry	1 ⁽¹⁾	C
RLA [m]	Rotate data memory left with result in ACC	1	None
RL [m]	Rotate data memory left	1 ⁽¹⁾	None
RLCA [m]	Rotate data memory left through carry with result in ACC	1	C
RLC [m]	Rotate data memory left through carry	1 ⁽¹⁾	C
Data Move			
MOV A,[m]	Move data memory to ACC	1	None
MOV [m],A	Move ACC to data memory	1 ⁽¹⁾	None
MOV A,x	Move immediate data to ACC	1	None
Bit Operation			
CLR [m].i	Clear bit of data memory	1 ⁽¹⁾	None
SET [m].i	Set bit of data memory	1 ⁽¹⁾	None

Mnemonic	Description	Instruction Cycle	Flag Affected
Branch			
JMP addr	Jump unconditionally	2	None
SZ [m]	Skip if data memory is zero	1 ⁽²⁾	None
SZA [m]	Skip if data memory is zero with data movement to ACC	1 ⁽²⁾	None
SZ [m].i	Skip if bit i of data memory is zero	1 ⁽²⁾	None
SNZ [m].i	Skip if bit i of data memory is not zero	1 ⁽²⁾	None
SIZ [m]	Skip if increment data memory is zero	1 ⁽³⁾	None
SDZ [m]	Skip if decrement data memory is zero	1 ⁽³⁾	None
SIZA [m]	Skip if increment data memory is zero with result in ACC	1 ⁽²⁾	None
SDZA [m]	Skip if decrement data memory is zero with result in ACC	1 ⁽²⁾	None
CALL addr	Subroutine call	2	None
RET	Return from subroutine	2	None
RET A,x	Return from subroutine and load immediate data to ACC	2	None
RETI	Return from interrupt	2	None
Table Read			
TABRDC [m]	Read ROM code (current page) to data memory and TBLH	2 ⁽¹⁾	None
TABRDL [m]	Read ROM code (last page) to data memory and TBLH	2 ⁽¹⁾	None
Miscellaneous			
NOP	No operation	1	None
CLR [m]	Clear data memory	1 ⁽¹⁾	None
SET [m]	Set data memory	1 ⁽¹⁾	None
CLR WDT	Clear Watchdog Timer	1	TO,PDF
CLR WDT1	Pre-clear Watchdog Timer	1	TO ⁽⁴⁾ ,PDF ⁽⁴⁾
CLR WDT2	Pre-clear Watchdog Timer	1	TO ⁽⁴⁾ ,PDF ⁽⁴⁾
SWAP [m]	Swap nibbles of data memory	1 ⁽¹⁾	None
SWAPA [m]	Swap nibbles of data memory with result in ACC	1	None
HALT	Enter power down mode	1	TO,PDF

Note: x: Immediate data

m: Data memory address

A: Accumulator

i: 0~7 number of bits

addr: Program memory address

√: Flag is affected

–: Flag is not affected

⁽¹⁾: If a loading to the PCL register occurs, the execution cycle of instructions will be delayed for one more cycle (four system clocks).

⁽²⁾: If a skipping to the next instruction occurs, the execution cycle of instructions will be delayed for one more cycle (four system clocks). Otherwise the original instruction cycle is unchanged.

⁽³⁾: ⁽¹⁾ and ⁽²⁾

⁽⁴⁾: The flags may be affected by the execution status. If the Watchdog Timer is cleared by executing the CLR WDT1 or CLR WDT2 instruction, the TO and PDF are cleared. Otherwise the TO and PDF flags remain unchanged.

Instruction Definition
ADC A,[m]

Add data memory and carry to the accumulator

Description

The contents of the specified data memory, accumulator and the carry flag are added simultaneously, leaving the result in the accumulator.

Operation

 $ACC \leftarrow ACC+[m]+C$

Affected flag(s)

TO	PDF	OV	Z	AC	C
—	—	√	√	√	√

ADCM A,[m]

Add the accumulator and carry to data memory

Description

The contents of the specified data memory, accumulator and the carry flag are added simultaneously, leaving the result in the specified data memory.

Operation

 $[m] \leftarrow ACC+[m]+C$

Affected flag(s)

TO	PDF	OV	Z	AC	C
—	—	√	√	√	√

ADD A,[m]

Add data memory to the accumulator

Description

The contents of the specified data memory and the accumulator are added. The result is stored in the accumulator.

Operation

 $ACC \leftarrow ACC+[m]$

Affected flag(s)

TO	PDF	OV	Z	AC	C
—	—	√	√	√	√

ADD A,x

Add immediate data to the accumulator

Description

The contents of the accumulator and the specified data are added, leaving the result in the accumulator.

Operation

 $ACC \leftarrow ACC+x$

Affected flag(s)

TO	PDF	OV	Z	AC	C
—	—	√	√	√	√

ADDM A,[m]

Add the accumulator to the data memory

Description

The contents of the specified data memory and the accumulator are added. The result is stored in the data memory.

Operation

 $[m] \leftarrow ACC+[m]$

Affected flag(s)

TO	PDF	OV	Z	AC	C
—	—	√	√	√	√

AND A,[m] Logical AND accumulator with data memory
 Description Data in the accumulator and the specified data memory perform a bitwise logical_AND operation. The result is stored in the accumulator.

Operation $ACC \leftarrow ACC \text{ "AND" } [m]$

Affected flag(s)

TO	PDF	OV	Z	AC	C
—	—	—	√	—	—

AND A,x Logical AND immediate data to the accumulator
 Description Data in the accumulator and the specified data perform a bitwise logical_AND operation. The result is stored in the accumulator.

Operation $ACC \leftarrow ACC \text{ "AND" } x$

Affected flag(s)

TO	PDF	OV	Z	AC	C
—	—	—	√	—	—

ANDM A,[m] Logical AND data memory with the accumulator
 Description Data in the specified data memory and the accumulator perform a bitwise logical_AND operation. The result is stored in the data memory.

Operation $[m] \leftarrow ACC \text{ "AND" } [m]$

Affected flag(s)

TO	PDF	OV	Z	AC	C
—	—	—	√	—	—

CALL addr Subroutine call
 Description The instruction unconditionally calls a subroutine located at the indicated address. The program counter increments once to obtain the address of the next instruction, and pushes this onto the stack. The indicated address is then loaded. Program execution continues with the instruction at this address.

Operation $Stack \leftarrow Program\ Counter + 1$
 $Program\ Counter \leftarrow addr$

Affected flag(s)

TO	PDF	OV	Z	AC	C
—	—	—	—	—	—

CLR [m] Clear data memory
 Description The contents of the specified data memory are cleared to 0.

Operation $[m] \leftarrow 00H$

Affected flag(s)

TO	PDF	OV	Z	AC	C
—	—	—	—	—	—

CLR [m].i Clear bit of data memory
 Description The bit i of the specified data memory is cleared to 0.
 Operation $[m].i \leftarrow 0$
 Affected flag(s)

TO	PDF	OV	Z	AC	C
—	—	—	—	—	—

CLR WDT Clear Watchdog Timer
 Description The WDT is cleared (clears the WDT). The power down bit (PDF) and time-out bit (TO) are cleared.
 Operation $WDT \leftarrow 00H$
 $PDF \text{ and } TO \leftarrow 0$
 Affected flag(s)

TO	PDF	OV	Z	AC	C
0	0	—	—	—	—

CLR WDT1 Preclear Watchdog Timer
 Description Together with CLR WDT2, clears the WDT. PDF and TO are also cleared. Only execution of this instruction without the other preclear instruction just sets the indicated flag which implies this instruction has been executed and the TO and PDF flags remain unchanged.
 Operation $WDT \leftarrow 00H^*$
 $PDF \text{ and } TO \leftarrow 0^*$
 Affected flag(s)

TO	PDF	OV	Z	AC	C
0*	0*	—	—	—	—

CLR WDT2 Preclear Watchdog Timer
 Description Together with CLR WDT1, clears the WDT. PDF and TO are also cleared. Only execution of this instruction without the other preclear instruction, sets the indicated flag which implies this instruction has been executed and the TO and PDF flags remain unchanged.
 Operation $WDT \leftarrow 00H^*$
 $PDF \text{ and } TO \leftarrow 0^*$
 Affected flag(s)

TO	PDF	OV	Z	AC	C
0*	0*	—	—	—	—

CPL [m] Complement data memory
 Description Each bit of the specified data memory is logically complemented (1's complement). Bits which previously contained a 1 are changed to 0 and vice-versa.
 Operation $[m] \leftarrow \overline{[m]}$
 Affected flag(s)

TO	PDF	OV	Z	AC	C
—	—	—	√	—	—

CPLA [m] Complement data memory and place result in the accumulator
 Description Each bit of the specified data memory is logically complemented (1's complement). Bits which previously contained a 1 are changed to 0 and vice-versa. The complemented result is stored in the accumulator and the contents of the data memory remain unchanged.

Operation $ACC \leftarrow \overline{[m]}$

Affected flag(s)

TO	PDF	OV	Z	AC	C
—	—	—	√	—	—

DAA [m] Decimal-Adjust accumulator for addition
 Description The accumulator value is adjusted to the BCD (Binary Coded Decimal) code. The accumulator is divided into two nibbles. Each nibble is adjusted to the BCD code and an internal carry (AC1) will be done if the low nibble of the accumulator is greater than 9. The BCD adjustment is done by adding 6 to the original value if the original value is greater than 9 or a carry (AC or C) is set; otherwise the original value remains unchanged. The result is stored in the data memory and only the carry flag (C) may be affected.

Operation
 If $ACC.3 \sim ACC.0 > 9$ or $AC=1$
 then $[m].3 \sim [m].0 \leftarrow (ACC.3 \sim ACC.0) + 6, AC1 = \overline{AC}$
 else $[m].3 \sim [m].0 \leftarrow (ACC.3 \sim ACC.0), AC1 = 0$
 and
 If $ACC.7 \sim ACC.4 + AC1 > 9$ or $C=1$
 then $[m].7 \sim [m].4 \leftarrow ACC.7 \sim ACC.4 + 6 + AC1, C=1$
 else $[m].7 \sim [m].4 \leftarrow ACC.7 \sim ACC.4 + AC1, C=C$

Affected flag(s)

TO	PDF	OV	Z	AC	C
—	—	—	—	—	√

DEC [m] Decrement data memory
 Description Data in the specified data memory is decremented by 1.

Operation $[m] \leftarrow [m] - 1$

Affected flag(s)

TO	PDF	OV	Z	AC	C
—	—	—	√	—	—

DECA [m] Decrement data memory and place result in the accumulator
 Description Data in the specified data memory is decremented by 1, leaving the result in the accumulator. The contents of the data memory remain unchanged.

Operation $ACC \leftarrow [m] - 1$

Affected flag(s)

TO	PDF	OV	Z	AC	C
—	—	—	√	—	—

HALT	Enter power down mode												
Description	This instruction stops program execution and turns off the system clock. The contents of the RAM and registers are retained. The WDT and prescaler are cleared. The power down bit (PDF) is set and the WDT time-out bit (TO) is cleared.												
Operation	Program Counter \leftarrow Program Counter+1 PDF \leftarrow 1 TO \leftarrow 0												
Affected flag(s)	<table border="1"> <thead> <tr> <th>TO</th> <th>PDF</th> <th>OV</th> <th>Z</th> <th>AC</th> <th>C</th> </tr> </thead> <tbody> <tr> <td>0</td> <td>1</td> <td>—</td> <td>—</td> <td>—</td> <td>—</td> </tr> </tbody> </table>	TO	PDF	OV	Z	AC	C	0	1	—	—	—	—
TO	PDF	OV	Z	AC	C								
0	1	—	—	—	—								
INC [m]	Increment data memory												
Description	Data in the specified data memory is incremented by 1												
Operation	[m] \leftarrow [m]+1												
Affected flag(s)	<table border="1"> <thead> <tr> <th>TO</th> <th>PDF</th> <th>OV</th> <th>Z</th> <th>AC</th> <th>C</th> </tr> </thead> <tbody> <tr> <td>—</td> <td>—</td> <td>—</td> <td>√</td> <td>—</td> <td>—</td> </tr> </tbody> </table>	TO	PDF	OV	Z	AC	C	—	—	—	√	—	—
TO	PDF	OV	Z	AC	C								
—	—	—	√	—	—								
INCA [m]	Increment data memory and place result in the accumulator												
Description	Data in the specified data memory is incremented by 1, leaving the result in the accumulator. The contents of the data memory remain unchanged.												
Operation	ACC \leftarrow [m]+1												
Affected flag(s)	<table border="1"> <thead> <tr> <th>TO</th> <th>PDF</th> <th>OV</th> <th>Z</th> <th>AC</th> <th>C</th> </tr> </thead> <tbody> <tr> <td>—</td> <td>—</td> <td>—</td> <td>√</td> <td>—</td> <td>—</td> </tr> </tbody> </table>	TO	PDF	OV	Z	AC	C	—	—	—	√	—	—
TO	PDF	OV	Z	AC	C								
—	—	—	√	—	—								
JMP addr	Directly jump												
Description	The program counter are replaced with the directly-specified address unconditionally, and control is passed to this destination.												
Operation	Program Counter \leftarrow addr												
Affected flag(s)	<table border="1"> <thead> <tr> <th>TO</th> <th>PDF</th> <th>OV</th> <th>Z</th> <th>AC</th> <th>C</th> </tr> </thead> <tbody> <tr> <td>—</td> <td>—</td> <td>—</td> <td>—</td> <td>—</td> <td>—</td> </tr> </tbody> </table>	TO	PDF	OV	Z	AC	C	—	—	—	—	—	—
TO	PDF	OV	Z	AC	C								
—	—	—	—	—	—								
MOV A,[m]	Move data memory to the accumulator												
Description	The contents of the specified data memory are copied to the accumulator.												
Operation	ACC \leftarrow [m]												
Affected flag(s)	<table border="1"> <thead> <tr> <th>TO</th> <th>PDF</th> <th>OV</th> <th>Z</th> <th>AC</th> <th>C</th> </tr> </thead> <tbody> <tr> <td>—</td> <td>—</td> <td>—</td> <td>—</td> <td>—</td> <td>—</td> </tr> </tbody> </table>	TO	PDF	OV	Z	AC	C	—	—	—	—	—	—
TO	PDF	OV	Z	AC	C								
—	—	—	—	—	—								

MOV A,x

Move immediate data to the accumulator

Description

The 8-bit data specified by the code is loaded into the accumulator.

Operation

 $ACC \leftarrow x$

Affected flag(s)

TO	PDF	OV	Z	AC	C
—	—	—	—	—	—

MOV [m],A

Move the accumulator to data memory

Description

The contents of the accumulator are copied to the specified data memory (one of the data memories).

Operation

 $[m] \leftarrow ACC$

Affected flag(s)

TO	PDF	OV	Z	AC	C
—	—	—	—	—	—

NOP

No operation

Description

No operation is performed. Execution continues with the next instruction.

Operation

 $Program\ Counter \leftarrow Program\ Counter + 1$

Affected flag(s)

TO	PDF	OV	Z	AC	C
—	—	—	—	—	—

OR A,[m]

Logical OR accumulator with data memory

Description

Data in the accumulator and the specified data memory (one of the data memories) perform a bitwise logical_OR operation. The result is stored in the accumulator.

Operation

 $ACC \leftarrow ACC \text{ "OR" } [m]$

Affected flag(s)

TO	PDF	OV	Z	AC	C
—	—	—	√	—	—

OR A,x

Logical OR immediate data to the accumulator

Description

Data in the accumulator and the specified data perform a bitwise logical_OR operation. The result is stored in the accumulator.

Operation

 $ACC \leftarrow ACC \text{ "OR" } x$

Affected flag(s)

TO	PDF	OV	Z	AC	C
—	—	—	√	—	—

ORM A,[m]

Logical OR data memory with the accumulator

Description

Data in the data memory (one of the data memories) and the accumulator perform a bitwise logical_OR operation. The result is stored in the data memory.

Operation

 $[m] \leftarrow ACC \text{ "OR" } [m]$

Affected flag(s)

TO	PDF	OV	Z	AC	C
—	—	—	√	—	—

RET

Return from subroutine

Description

The program counter is restored from the stack. This is a 2-cycle instruction.

Operation

 Program Counter \leftarrow Stack

Affected flag(s)

TO	PDF	OV	Z	AC	C
—	—	—	—	—	—

RET A,x

Return and place immediate data in the accumulator

Description

The program counter is restored from the stack and the accumulator loaded with the specified 8-bit immediate data.

Operation

 Program Counter \leftarrow Stack

 ACC \leftarrow x

Affected flag(s)

TO	PDF	OV	Z	AC	C
—	—	—	—	—	—

RETI

Return from interrupt

Description

The program counter is restored from the stack, and interrupts are enabled by setting the EMI bit. EMI is the enable master (global) interrupt bit.

Operation

 Program Counter \leftarrow Stack

 EMI \leftarrow 1

Affected flag(s)

TO	PDF	OV	Z	AC	C
—	—	—	—	—	—

RL [m]

Rotate data memory left

Description

The contents of the specified data memory are rotated 1 bit left with bit 7 rotated into bit 0.

Operation

 $[m].(i+1) \leftarrow [m].i$; $[m].i$:bit i of the data memory ($i=0\sim 6$)

 $[m].0 \leftarrow [m].7$

Affected flag(s)

TO	PDF	OV	Z	AC	C
—	—	—	—	—	—

RLA [m]

Rotate data memory left and place result in the accumulator

Description

Data in the specified data memory is rotated 1 bit left with bit 7 rotated into bit 0, leaving the rotated result in the accumulator. The contents of the data memory remain unchanged.

Operation

 $ACC.(i+1) \leftarrow [m].i$; $[m].i$:bit i of the data memory ($i=0\sim 6$)

 $ACC.0 \leftarrow [m].7$

Affected flag(s)

TO	PDF	OV	Z	AC	C
—	—	—	—	—	—

RLC [m]	Rotate data memory left through carry												
Description	The contents of the specified data memory and the carry flag are rotated 1 bit left. Bit 7 replaces the carry bit; the original carry flag is rotated into the bit 0 position.												
Operation	$[m].(i+1) \leftarrow [m].i$; $[m].i$:bit i of the data memory ($i=0\sim 6$) $[m].0 \leftarrow C$ $C \leftarrow [m].7$												
Affected flag(s)	<table border="1" style="width: 100%; text-align: center;"> <thead> <tr> <th>TO</th> <th>PDF</th> <th>OV</th> <th>Z</th> <th>AC</th> <th>C</th> </tr> </thead> <tbody> <tr> <td>—</td> <td>—</td> <td>—</td> <td>—</td> <td>—</td> <td>√</td> </tr> </tbody> </table>	TO	PDF	OV	Z	AC	C	—	—	—	—	—	√
TO	PDF	OV	Z	AC	C								
—	—	—	—	—	√								
RLCA [m]	Rotate left through carry and place result in the accumulator												
Description	Data in the specified data memory and the carry flag are rotated 1 bit left. Bit 7 replaces the carry bit and the original carry flag is rotated into bit 0 position. The rotated result is stored in the accumulator but the contents of the data memory remain unchanged.												
Operation	$ACC.(i+1) \leftarrow [m].i$; $[m].i$:bit i of the data memory ($i=0\sim 6$) $ACC.0 \leftarrow C$ $C \leftarrow [m].7$												
Affected flag(s)	<table border="1" style="width: 100%; text-align: center;"> <thead> <tr> <th>TO</th> <th>PDF</th> <th>OV</th> <th>Z</th> <th>AC</th> <th>C</th> </tr> </thead> <tbody> <tr> <td>—</td> <td>—</td> <td>—</td> <td>—</td> <td>—</td> <td>√</td> </tr> </tbody> </table>	TO	PDF	OV	Z	AC	C	—	—	—	—	—	√
TO	PDF	OV	Z	AC	C								
—	—	—	—	—	√								
RR [m]	Rotate data memory right												
Description	The contents of the specified data memory are rotated 1 bit right with bit 0 rotated to bit 7.												
Operation	$[m].i \leftarrow [m].(i+1)$; $[m].i$:bit i of the data memory ($i=0\sim 6$) $[m].7 \leftarrow [m].0$												
Affected flag(s)	<table border="1" style="width: 100%; text-align: center;"> <thead> <tr> <th>TO</th> <th>PDF</th> <th>OV</th> <th>Z</th> <th>AC</th> <th>C</th> </tr> </thead> <tbody> <tr> <td>—</td> <td>—</td> <td>—</td> <td>—</td> <td>—</td> <td>—</td> </tr> </tbody> </table>	TO	PDF	OV	Z	AC	C	—	—	—	—	—	—
TO	PDF	OV	Z	AC	C								
—	—	—	—	—	—								
RRA [m]	Rotate right and place result in the accumulator												
Description	Data in the specified data memory is rotated 1 bit right with bit 0 rotated into bit 7, leaving the rotated result in the accumulator. The contents of the data memory remain unchanged.												
Operation	$ACC.(i) \leftarrow [m].(i+1)$; $[m].i$:bit i of the data memory ($i=0\sim 6$) $ACC.7 \leftarrow [m].0$												
Affected flag(s)	<table border="1" style="width: 100%; text-align: center;"> <thead> <tr> <th>TO</th> <th>PDF</th> <th>OV</th> <th>Z</th> <th>AC</th> <th>C</th> </tr> </thead> <tbody> <tr> <td>—</td> <td>—</td> <td>—</td> <td>—</td> <td>—</td> <td>—</td> </tr> </tbody> </table>	TO	PDF	OV	Z	AC	C	—	—	—	—	—	—
TO	PDF	OV	Z	AC	C								
—	—	—	—	—	—								
RRC [m]	Rotate data memory right through carry												
Description	The contents of the specified data memory and the carry flag are together rotated 1 bit right. Bit 0 replaces the carry bit; the original carry flag is rotated into the bit 7 position.												
Operation	$[m].i \leftarrow [m].(i+1)$; $[m].i$:bit i of the data memory ($i=0\sim 6$) $[m].7 \leftarrow C$ $C \leftarrow [m].0$												
Affected flag(s)	<table border="1" style="width: 100%; text-align: center;"> <thead> <tr> <th>TO</th> <th>PDF</th> <th>OV</th> <th>Z</th> <th>AC</th> <th>C</th> </tr> </thead> <tbody> <tr> <td>—</td> <td>—</td> <td>—</td> <td>—</td> <td>—</td> <td>√</td> </tr> </tbody> </table>	TO	PDF	OV	Z	AC	C	—	—	—	—	—	√
TO	PDF	OV	Z	AC	C								
—	—	—	—	—	√								

RRCA [m]	Rotate right through carry and place result in the accumulator												
Description	Data of the specified data memory and the carry flag are rotated 1 bit right. Bit 0 replaces the carry bit and the original carry flag is rotated into the bit 7 position. The rotated result is stored in the accumulator. The contents of the data memory remain unchanged.												
Operation	$ACC.i \leftarrow [m].(i+1); [m].i:bit\ i\ of\ the\ data\ memory\ (i=0\sim 6)$ $ACC.7 \leftarrow C$ $C \leftarrow [m].0$												
Affected flag(s)	<table border="1" style="width: 100%; text-align: center;"> <thead> <tr> <th>TO</th> <th>PDF</th> <th>OV</th> <th>Z</th> <th>AC</th> <th>C</th> </tr> </thead> <tbody> <tr> <td>—</td> <td>—</td> <td>—</td> <td>—</td> <td>—</td> <td>√</td> </tr> </tbody> </table>	TO	PDF	OV	Z	AC	C	—	—	—	—	—	√
TO	PDF	OV	Z	AC	C								
—	—	—	—	—	√								
SBC A,[m]	Subtract data memory and carry from the accumulator												
Description	The contents of the specified data memory and the complement of the carry flag are subtracted from the accumulator, leaving the result in the accumulator.												
Operation	$ACC \leftarrow ACC + \overline{[m]} + C$												
Affected flag(s)	<table border="1" style="width: 100%; text-align: center;"> <thead> <tr> <th>TO</th> <th>PDF</th> <th>OV</th> <th>Z</th> <th>AC</th> <th>C</th> </tr> </thead> <tbody> <tr> <td>—</td> <td>—</td> <td>√</td> <td>√</td> <td>√</td> <td>√</td> </tr> </tbody> </table>	TO	PDF	OV	Z	AC	C	—	—	√	√	√	√
TO	PDF	OV	Z	AC	C								
—	—	√	√	√	√								
SBCM A,[m]	Subtract data memory and carry from the accumulator												
Description	The contents of the specified data memory and the complement of the carry flag are subtracted from the accumulator, leaving the result in the data memory.												
Operation	$[m] \leftarrow ACC + \overline{[m]} + C$												
Affected flag(s)	<table border="1" style="width: 100%; text-align: center;"> <thead> <tr> <th>TO</th> <th>PDF</th> <th>OV</th> <th>Z</th> <th>AC</th> <th>C</th> </tr> </thead> <tbody> <tr> <td>—</td> <td>—</td> <td>√</td> <td>√</td> <td>√</td> <td>√</td> </tr> </tbody> </table>	TO	PDF	OV	Z	AC	C	—	—	√	√	√	√
TO	PDF	OV	Z	AC	C								
—	—	√	√	√	√								
SDZ [m]	Skip if decrement data memory is 0												
Description	The contents of the specified data memory are decremented by 1. If the result is 0, the next instruction is skipped. If the result is 0, the following instruction, fetched during the current instruction execution, is discarded and a dummy cycle is replaced to get the proper instruction (2 cycles). Otherwise proceed with the next instruction (1 cycle).												
Operation	Skip if $([m]-1)=0$, $[m] \leftarrow ([m]-1)$												
Affected flag(s)	<table border="1" style="width: 100%; text-align: center;"> <thead> <tr> <th>TO</th> <th>PDF</th> <th>OV</th> <th>Z</th> <th>AC</th> <th>C</th> </tr> </thead> <tbody> <tr> <td>—</td> <td>—</td> <td>—</td> <td>—</td> <td>—</td> <td>—</td> </tr> </tbody> </table>	TO	PDF	OV	Z	AC	C	—	—	—	—	—	—
TO	PDF	OV	Z	AC	C								
—	—	—	—	—	—								
SDZA [m]	Decrement data memory and place result in ACC, skip if 0												
Description	The contents of the specified data memory are decremented by 1. If the result is 0, the next instruction is skipped. The result is stored in the accumulator but the data memory remains unchanged. If the result is 0, the following instruction, fetched during the current instruction execution, is discarded and a dummy cycle is replaced to get the proper instruction (2 cycles). Otherwise proceed with the next instruction (1 cycle).												
Operation	Skip if $([m]-1)=0$, $ACC \leftarrow ([m]-1)$												
Affected flag(s)	<table border="1" style="width: 100%; text-align: center;"> <thead> <tr> <th>TO</th> <th>PDF</th> <th>OV</th> <th>Z</th> <th>AC</th> <th>C</th> </tr> </thead> <tbody> <tr> <td>—</td> <td>—</td> <td>—</td> <td>—</td> <td>—</td> <td>—</td> </tr> </tbody> </table>	TO	PDF	OV	Z	AC	C	—	—	—	—	—	—
TO	PDF	OV	Z	AC	C								
—	—	—	—	—	—								

SET [m] Set data memory
 Description Each bit of the specified data memory is set to 1.
 Operation $[m] \leftarrow FFH$
 Affected flag(s)

TO	PDF	OV	Z	AC	C
—	—	—	—	—	—

SET [m]. i Set bit of data memory
 Description Bit i of the specified data memory is set to 1.
 Operation $[m].i \leftarrow 1$
 Affected flag(s)

TO	PDF	OV	Z	AC	C
—	—	—	—	—	—

SIZ [m] Skip if increment data memory is 0
 Description The contents of the specified data memory are incremented by 1. If the result is 0, the following instruction, fetched during the current instruction execution, is discarded and a dummy cycle is replaced to get the proper instruction (2 cycles). Otherwise proceed with the next instruction (1 cycle).
 Operation Skip if $([m]+1)=0$, $[m] \leftarrow ([m]+1)$
 Affected flag(s)

TO	PDF	OV	Z	AC	C
—	—	—	—	—	—

SIZA [m] Increment data memory and place result in ACC, skip if 0
 Description The contents of the specified data memory are incremented by 1. If the result is 0, the next instruction is skipped and the result is stored in the accumulator. The data memory remains unchanged. If the result is 0, the following instruction, fetched during the current instruction execution, is discarded and a dummy cycle is replaced to get the proper instruction (2 cycles). Otherwise proceed with the next instruction (1 cycle).
 Operation Skip if $([m]+1)=0$, $ACC \leftarrow ([m]+1)$
 Affected flag(s)

TO	PDF	OV	Z	AC	C
—	—	—	—	—	—

SNZ [m].i Skip if bit i of the data memory is not 0
 Description If bit i of the specified data memory is not 0, the next instruction is skipped. If bit i of the data memory is not 0, the following instruction, fetched during the current instruction execution, is discarded and a dummy cycle is replaced to get the proper instruction (2 cycles). Otherwise proceed with the next instruction (1 cycle).
 Operation Skip if $[m].i \neq 0$
 Affected flag(s)

TO	PDF	OV	Z	AC	C
—	—	—	—	—	—

SUB A,[m] Subtract data memory from the accumulator
 Description The specified data memory is subtracted from the contents of the accumulator, leaving the result in the accumulator.

Operation $ACC \leftarrow ACC + \overline{[m]} + 1$

Affected flag(s)

TO	PDF	OV	Z	AC	C
—	—	√	√	√	√

SUBM A,[m] Subtract data memory from the accumulator
 Description The specified data memory is subtracted from the contents of the accumulator, leaving the result in the data memory.

Operation $[m] \leftarrow ACC + \overline{[m]} + 1$

Affected flag(s)

TO	PDF	OV	Z	AC	C
—	—	√	√	√	√

SUB A,x Subtract immediate data from the accumulator
 Description The immediate data specified by the code is subtracted from the contents of the accumulator, leaving the result in the accumulator.

Operation $ACC \leftarrow ACC + \overline{x} + 1$

Affected flag(s)

TO	PDF	OV	Z	AC	C
—	—	√	√	√	√

SWAP [m] Swap nibbles within the data memory
 Description The low-order and high-order nibbles of the specified data memory (1 of the data memories) are interchanged.

Operation $[m].3 \sim [m].0 \leftrightarrow [m].7 \sim [m].4$

Affected flag(s)

TO	PDF	OV	Z	AC	C
—	—	—	—	—	—

SWAPA [m] Swap data memory and place result in the accumulator
 Description The low-order and high-order nibbles of the specified data memory are interchanged, writing the result to the accumulator. The contents of the data memory remain unchanged.

Operation $ACC.3 \sim ACC.0 \leftarrow [m].7 \sim [m].4$

$ACC.7 \sim ACC.4 \leftarrow [m].3 \sim [m].0$

Affected flag(s)

TO	PDF	OV	Z	AC	C
—	—	—	—	—	—

SZ [m] Skip if data memory is 0

Description If the contents of the specified data memory are 0, the following instruction, fetched during the current instruction execution, is discarded and a dummy cycle is replaced to get the proper instruction (2 cycles). Otherwise proceed with the next instruction (1 cycle).

Operation Skip if [m]=0

Affected flag(s)

TO	PDF	OV	Z	AC	C
—	—	—	—	—	—

SZA [m] Move data memory to ACC, skip if 0

Description The contents of the specified data memory are copied to the accumulator. If the contents is 0, the following instruction, fetched during the current instruction execution, is discarded and a dummy cycle is replaced to get the proper instruction (2 cycles). Otherwise proceed with the next instruction (1 cycle).

Operation Skip if [m]=0

Affected flag(s)

TO	PDF	OV	Z	AC	C
—	—	—	—	—	—

SZ [m].i Skip if bit i of the data memory is 0

Description If bit i of the specified data memory is 0, the following instruction, fetched during the current instruction execution, is discarded and a dummy cycle is replaced to get the proper instruction (2 cycles). Otherwise proceed with the next instruction (1 cycle).

Operation Skip if [m].i=0

Affected flag(s)

TO	PDF	OV	Z	AC	C
—	—	—	—	—	—

TABRDC [m] Move the ROM code (current page) to TBLH and data memory

Description The low byte of ROM code (current page) addressed by the table pointer (TBLP) is moved to the specified data memory and the high byte transferred to TBLH directly.

Operation [m] ← ROM code (low byte)
TBLH ← ROM code (high byte)

Affected flag(s)

TO	PDF	OV	Z	AC	C
—	—	—	—	—	—

TABRDL [m] Move the ROM code (last page) to TBLH and data memory

Description The low byte of ROM code (last page) addressed by the table pointer (TBLP) is moved to the data memory and the high byte transferred to TBLH directly.

Operation [m] ← ROM code (low byte)
TBLH ← ROM code (high byte)

Affected flag(s)

TO	PDF	OV	Z	AC	C
—	—	—	—	—	—

XOR A,[m] Logical XOR accumulator with data memory

Description Data in the accumulator and the indicated data memory perform a bitwise logical Exclusive_OR operation and the result is stored in the accumulator.

Operation $ACC \leftarrow ACC \text{ "XOR" } [m]$

Affected flag(s)

TO	PDF	OV	Z	AC	C
—	—	—	√	—	—

XORM A,[m] Logical XOR data memory with the accumulator

Description Data in the indicated data memory and the accumulator perform a bitwise logical Exclusive_OR operation. The result is stored in the data memory. The 0 flag is affected.

Operation $[m] \leftarrow ACC \text{ "XOR" } [m]$

Affected flag(s)

TO	PDF	OV	Z	AC	C
—	—	—	√	—	—

XOR A,x Logical XOR immediate data to the accumulator

Description Data in the accumulator and the specified data perform a bitwise logical Exclusive_OR operation. The result is stored in the accumulator. The 0 flag is affected.

Operation $ACC \leftarrow ACC \text{ "XOR" } x$

Affected flag(s)

TO	PDF	OV	Z	AC	C
—	—	—	√	—	—

Package Information

48-pin SSOP (300mil) Outline Dimensions

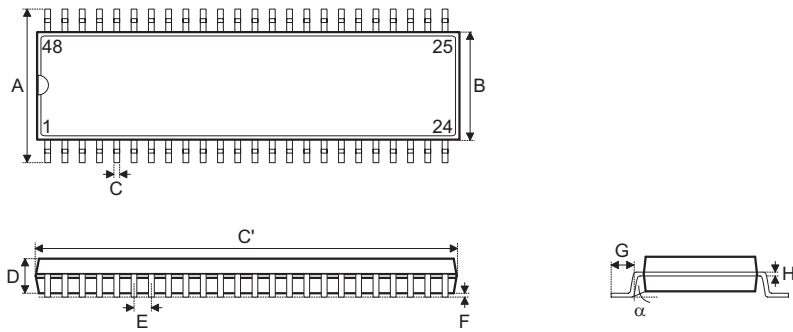

Symbol	Dimensions in mil		
	Min.	Nom.	Max.
A	395	—	420
B	291	—	299
C	8	—	12
C'	613	—	637
D	85	—	99
E	—	25	—
F	4	—	10
G	25	—	35
H	4	—	12
α	0°	—	8°

Product Tape and Reel Specifications

Reel Dimensions

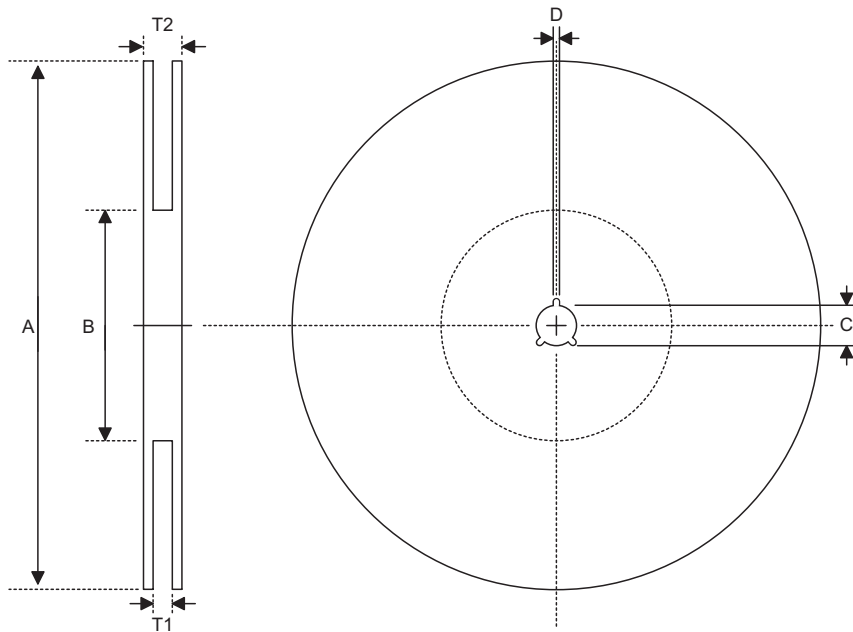

SSOP 48W

Symbol	Description	Dimensions in mm
A	Reel Outer Diameter	330±1.0
B	Reel Inner Diameter	100±0.1
C	Spindle Hole Diameter	13.0+0.5 -0.2
D	Key Slit Width	2.0±0.5
T1	Space Between Flange	32.2+0.3 -0.2
T2	Reel Thickness	38.2±0.2

Carrier Tape Dimensions

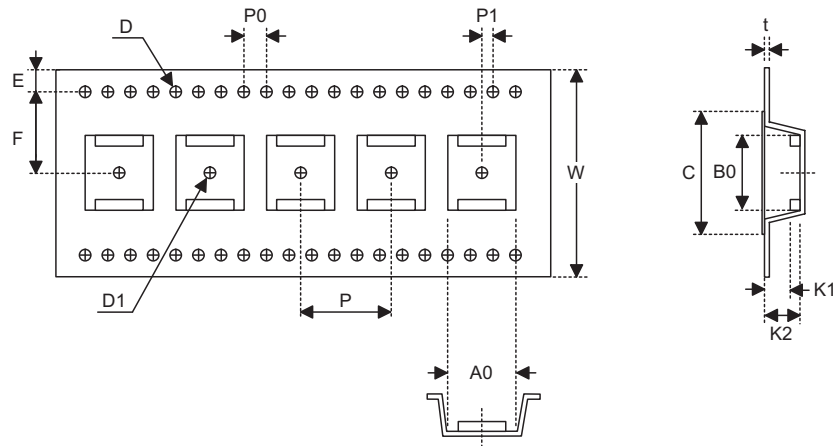

SSOP 48W

Symbol	Description	Dimensions in mm
W	Carrier Tape Width	32.0±0.3
P	Cavity Pitch	16.0±0.1
E	Perforation Position	1.75±0.1
F	Cavity to Perforation (Width Direction)	14.2±0.1
D	Perforation Diameter	2.0 Min.
D1	Cavity Hole Diameter	1.5+0.25
P0	Perforation Pitch	4.0±0.1
P1	Cavity to Perforation (Length Direction)	2.0±0.1
A0	Cavity Length	12.0±0.1
B0	Cavity Width	16.20±0.1
K1	Cavity Depth	2.4±0.1
K2	Cavity Depth	3.2±0.1
t	Carrier Tape Thickness	0.35±0.05
C	Cover Tape Width	25.5

Holtek Semiconductor Inc. (Headquarters)

No.3, Creation Rd. II, Science Park, Hsinchu, Taiwan
Tel: 886-3-563-1999
Fax: 886-3-563-1189
<http://www.holtek.com.tw>

Holtek Semiconductor Inc. (Taipei Sales Office)

4F-2, No. 3-2, YuanQu St., Nankang Software Park, Taipei 115, Taiwan
Tel: 886-2-2655-7070
Fax: 886-2-2655-7373
Fax: 886-2-2655-7383 (International sales hotline)

Holtek Semiconductor Inc. (Shanghai Sales Office)

7th Floor, Building 2, No.889, Yi Shan Rd., Shanghai, China 200233
Tel: 021-6485-5560
Fax: 021-6485-0313
<http://www.holtek.com.cn>

Holtek Semiconductor Inc. (Shenzhen Sales Office)

5/F, Unit A, Productivity Building, Cross of Science M 3rd Road and Gaoxin M 2nd Road, Science Park, Nanshan District, Shenzhen, China 518057
Tel: 0755-8616-9908, 8616-9308
Fax: 0755-8616-9533

Holtek Semiconductor Inc. (Beijing Sales Office)

Suite 1721, Jinyu Tower, A129 West Xuan Wu Men Street, Xicheng District, Beijing, China 100031
Tel: 010-6641-0030, 6641-7751, 6641-7752
Fax: 010-6641-0125

Holtek Semiconductor Inc. (Chengdu Sales Office)

709, Building 3, Champagne Plaza, No.97 Dongda Street, Chengdu, Sichuan, China 610016
Tel: 028-6653-6590
Fax: 028-6653-6591

Holmate Semiconductor, Inc. (North America Sales Office)

46729 Fremont Blvd., Fremont, CA 94538
Tel: 510-252-9880
Fax: 510-252-9885
<http://www.holmate.com>

Copyright © 2006 by HOLTEK SEMICONDUCTOR INC.

The information appearing in this Data Sheet is believed to be accurate at the time of publication. However, Holtek assumes no responsibility arising from the use of the specifications described. The applications mentioned herein are used solely for the purpose of illustration and Holtek makes no warranty or representation that such applications will be suitable without further modification, nor recommends the use of its products for application that may present a risk to human life due to malfunction or otherwise. Holtek's products are not authorized for use as critical components in life support devices or systems. Holtek reserves the right to alter its products without prior notification. For the most up-to-date information, please visit our web site at <http://www.holtek.com.tw>.