

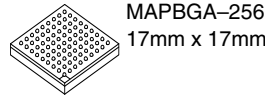

MCF54455

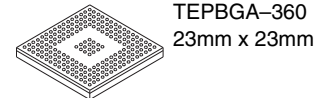

MAPBGA-256
17mm x 17mm



TEPBGA-360
23mm x 23mm

MCF5445x ColdFire® Microprocessor Data Sheet

Features

- Version 4 ColdFire® Core with MMU and EMAC
- Up to 410 Dhrystone 2.1 MIPS @ 266 MHz
- 16-KBytes instruction cache and 16-KBytes data cache
- 32-KBytes internal SRAM
- Support for booting from SPI-compatible flash, EEPROM, and FRAM devices
- Crossbar switch technology (XBS) for concurrent access to peripherals or RAM from multiple bus masters
- 16-channel DMA controller
- 16-bit 133-MHz DDR/mobile-DDR/DDR2 controller
- USB 2.0 On-the-Go controller with ULPI support
- 32-bit PCI controller @ 66MHz
- ATA/ATAPI controller
- 2 10/100 Ethernet MACs
- Coprocessor for acceleration of the DES, 3DES, AES, MD5, and SHA-1 algorithms
- Random number generator
- Synchronous serial interface (SSI)
- 4 periodic interrupt timers (PIT)
- 4 32-bit timers with DMA support
- DMA-supported serial peripheral interface (DSPI)
- 3 UARTs
- I²C bus interface

This document contains information on a new product. Specifications and information herein are subject to change without notice.

© Freescale Semiconductor, Inc., 2008. All rights reserved.

Table of Contents

1	MCF5445x Family Comparison	4	5.9	PCI Bus Timing Specifications	27
2	Ordering Information	5	5.9.1	Overshoot and Undershoot	28
3	Hardware Design Considerations	5	5.10	ULPI Timing Specifications	29
3.1	Analog Power Filtering	5	5.11	SSI Timing Specifications	30
3.2	Oscillator Power Filtering	6	5.12	I ² C Timing Specifications	32
3.3	Supply Voltage Sequencing	6	5.13	Fast Ethernet Timing Specifications	33
3.3.1	Power-Up Sequence	7	5.13.1	Receive Signal Timing Specifications	33
3.3.2	Power-Down Sequence	7	5.13.2	Transmit Signal Timing Specifications	34
4	Pin Assignments and Reset States	7	5.13.3	Asynchronous Input Signal Timing Specifications	34
4.1	Signal Multiplexing	7	5.13.4	MII Serial Management Timing Specifications	35
4.2	Pinout—256 MAPBGA	15	5.14	32-Bit Timer Module Timing Specifications	35
4.3	Pinout—360 TEPBGA	16	5.15	ATA Interface Timing Specifications	36
5	Electrical Characteristics	17	5.16	DSPI Timing Specifications	36
5.1	Absolute Maximum Ratings	17	5.17	SBF Timing Specifications	38
5.2	Thermal Characteristics	18	5.18	General Purpose I/O Timing Specifications	39
5.3	ESD Protection	19	5.19	JTAG and Boundary Scan Timing	40
5.4	DC Electrical Specifications	19	5.20	Debug AC Timing Specifications	42
5.5	Clock Timing Specifications	20	6	Power Consumption	43
5.6	Reset Timing Specifications	22	7	Package Information	45
5.7	FlexBus Timing Specifications	23	8	Product Documentation	45
5.8	SDRAM AC Timing Characteristics	25	9	Revision History	46

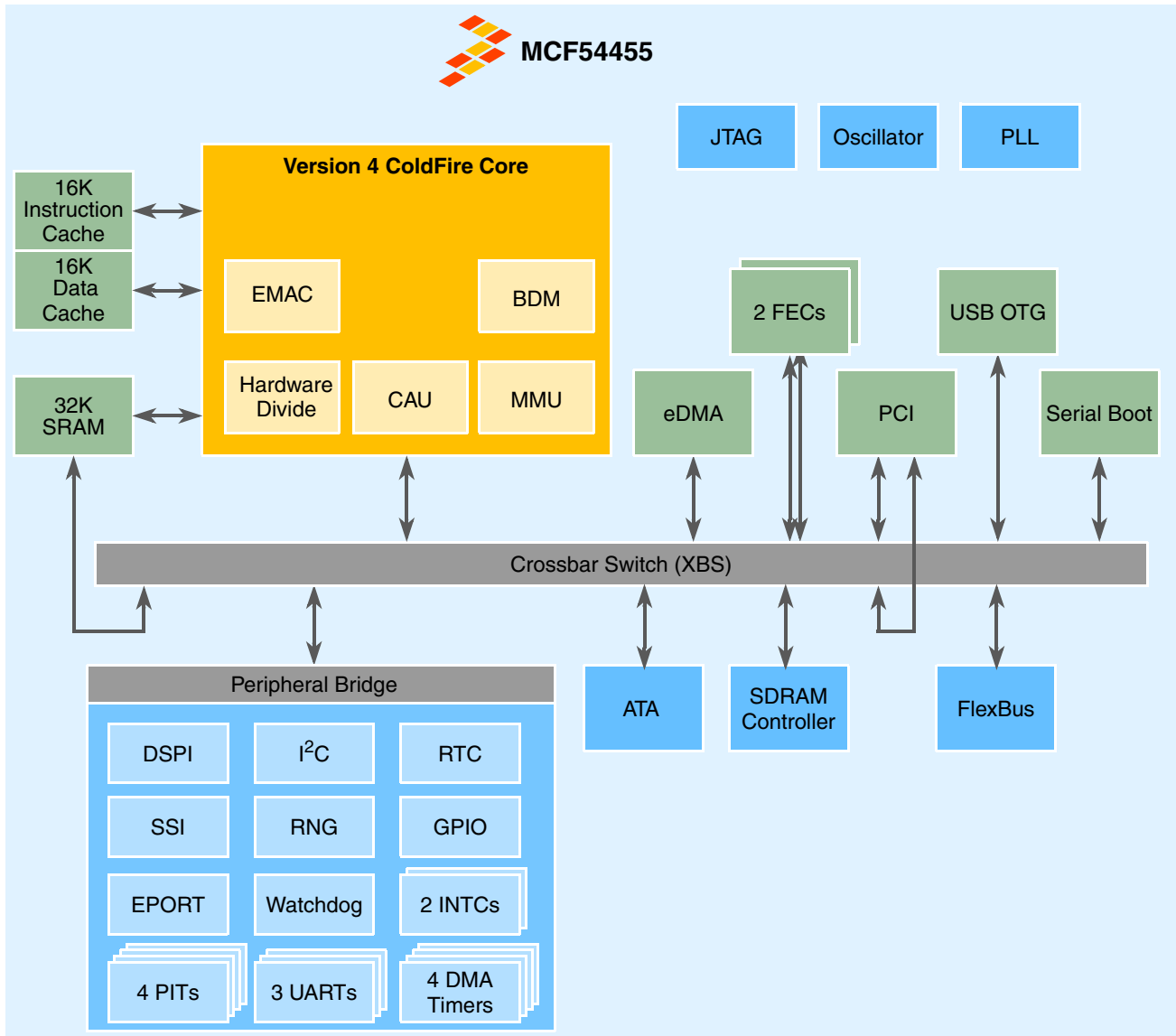

LEGEND

- | | | | |
|-----------------------|---------------------------------------------|----------------|---------------------------------------------|
| ATA | – Advanced Technology Attachment Controller | INTC | – Interrupt controller |
| BDM | – Background debug module | JTAG | – Joint Test Action Group interface |
| CAU | – Cryptography acceleration unit | MMU | – Memory management unit |
| DSPI | – DMA serial peripheral interface | PCI | – Peripheral Component Interconnect |
| eDMA | – Enhanced direct memory access | PIT | – Programmable interrupt timers |
| EMAC | – Enhance multiply-accumulate unit | PLL | – Phase locked loop module |
| EPORT | – Edge port module | RNG | – Random Number Generator |
| FEC | – Fast Ethernet Controller | RTC | – Real time clock |
| GPIO | – General Purpose Input/Output Module | SSI | – Synchronous Serial Interface |
| I²C | – Inter-Integrated Circuit | USB OTG | – Universal Serial Bus On-the-Go controller |

Figure 1. MCF54455 Block Diagram

1 MCF5445x Family Comparison

The following table compares the various device derivatives available within the MCF5445x family.

Table 1. MCF5445x Family Configurations

Module	MCF54450	MCF54451	MCF54452	MCF54453	MCF54454	MCF54455
ColdFire Version 4 Core with EMAC (Enhanced Multiply-Accumulate Unit)	•	•	•	•	•	•
Core (System) Clock	up to 240 MHz		up to 266 MHz			
Peripheral Bus Clock (Core clock ÷ 2)	up to 120 MHz		up to 133 MHz			
External Bus Clock (Core clock ÷ 4)	up to 60 MHz		up to 66 MHz			
Performance (Dhrystone/2.1 MIPS)	up to 370		up to 410			
Independent Data/Instruction Cache	16 KBytes each					
Static RAM (SRAM)	32 KBytes					
PCI Controller	•	•	•	•	•	•
Cryptography Acceleration Unit (CAU)	—	•	—	•	—	•
ATA Controller	—	—	—	—	•	•
DDR SDRAM Controller	•	•	•	•	•	•
FlexBus External Interface	•	•	•	•	•	•
USB 2.0 On-the-Go	•	•	•	•	•	•
UTMI+ Low Pin Interface (ULPI)	•	•	•	•	•	•
Synchronous Serial Interface (SSI)	•	•	•	•	•	•
Fast Ethernet Controller (FEC)	1	1	2	2	2	2
UARTs	3	3	3	3	3	3
I ² C	•	•	•	•	•	•
DSPI	•	•	•	•	•	•
Real Time Clock	•	•	•	•	•	•
32-bit DMA Timers	4	4	4	4	4	4
Watchdog Timer (WDT)	•	•	•	•	•	•
Periodic Interrupt Timers (PIT)	4	4	4	4	4	4
Edge Port Module (EPORT)	•	•	•	•	•	•
Interrupt Controllers (INTC)	2	2	2	2	2	2
16-channel Direct Memory Access (DMA)	•	•	•	•	•	•
General Purpose I/O Module (GPIO)	•	•	•	•	•	•
JTAG — IEEE® 1149.1 Test Access Port	•	•	•	•	•	•
Package	256 MAPBGA		360 TEPBGA			

2 Ordering Information

Table 2. Orderable Part Numbers

Freescall Part Number	Description	Package	Speed	Temperature
MCF54450VM180	MCF54450 Microprocessor	256 MAPBGA	180 MHz	0° to +70° C
MCF54450VM240			240 MHz	
MCF54451CVM180	MCF54451 Microprocessor		180 MHz	-40° to +85° C
MCF54451VM240			240 MHz	0° to +70° C
MCF54452CVR200	MCF54452 Microprocessor	360 TEPBGA	200 MHz	-40° to +85° C
MCF54452VR266			266 MHz	0° to +70° C
MCF54453CVR200	MCF54453 Microprocessor		200 MHz	-40° to +85° C
MCF54453VR266			266 MHz	0° to +70° C
MCF54454CVR200	MCF54454 Microprocessor		200 MHz	-40° to +85° C
MCF54454VR266			266 MHz	0° to +70° C
MCF54455CVR200	MCF54455 Microprocessor		200 MHz	-40° to +85° C
MCF54455VR266			266 MHz	0° to +70° C

3 Hardware Design Considerations

3.1 Analog Power Filtering

To further enhance noise isolation, an external filter is strongly recommended for the analog V_{DD} pins ($V_{DD_A_PLL}$, V_{DD_RTC}). The filter shown in Figure 2 should be connected between the board IV_{DD} and the analog pins. The resistor and capacitors should be placed as close to the dedicated analog V_{DD} pin as possible. The 10- Ω resistor in the given filter is required. Do not implement the filter circuit using only capacitors. The analog power pins draw very little current. Concerns regarding voltage loss across the 10-ohm resistor are not valid.

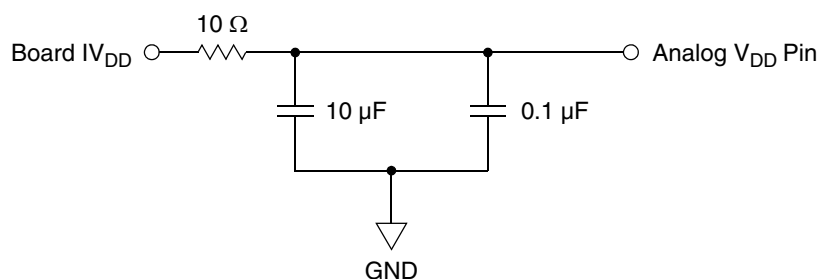

Figure 2. System Analog V_{DD} Power Filter

3.2 Oscillator Power Filtering

Figure 3 shows an example for isolating the oscillator power supply from the I/O supply (EVDD) and ground.

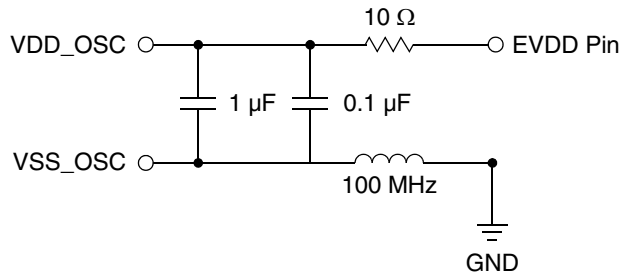
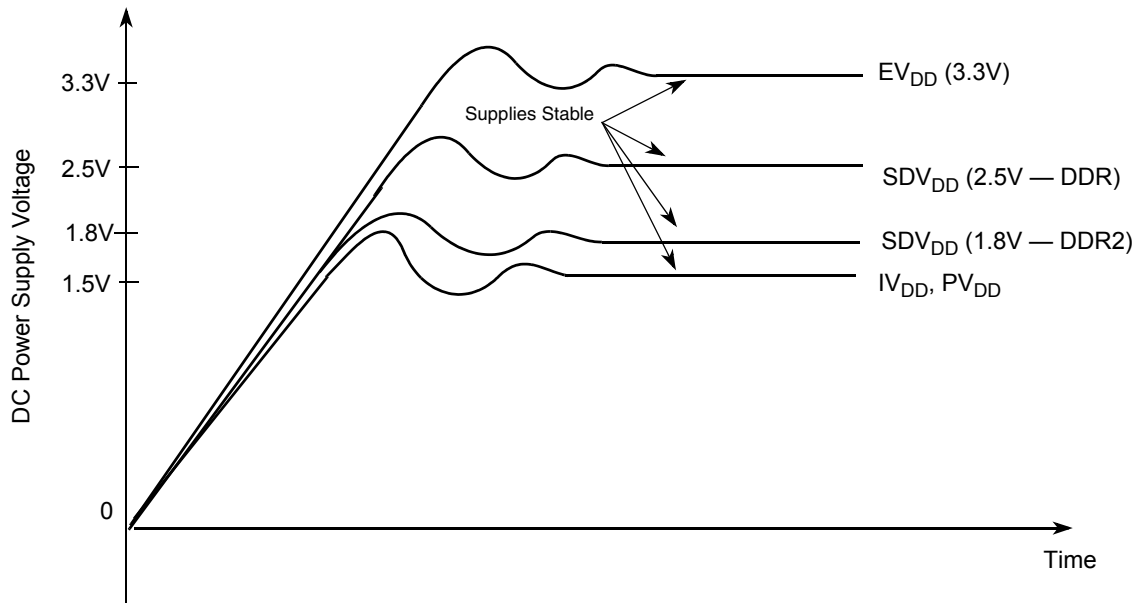

Figure 3. Oscillator Power Filter

3.3 Supply Voltage Sequencing

Figure 4 shows situations in sequencing the I/O V_{DD} (EV_{DD}), SDRAM V_{DD} (SDV_{DD}), PLL V_{DD} (PV_{DD}), and internal logic/core V_{DD} (IV_{DD}).



Notes:

- 1 Input voltage must not be greater than the supply voltage (EV_{DD} , SDV_{DD} , IV_{DD} , or PV_{DD}) by more than 0.5V at any time, including during power-up.
- 2 Use 50 V/millisecond or slower rise time for all supplies.

Figure 4. Supply Voltage Sequencing and Separation Cautions

The relationship between SDV_{DD} and EV_{DD} is non-critical during power-up and power-down sequences. SDV_{DD} (2.5V or 1.8V) and EV_{DD} are specified relative to IV_{DD} .

3.3.1 Power-Up Sequence

If EV_{DD}/SDV_{DD} are powered up with the IV_{DD} at 0 V, the sense circuits in the I/O pads cause all pad output drivers connected to the EV_{DD}/SDV_{DD} to be in a high impedance state. There is no limit on how long after EV_{DD}/SDV_{DD} powers up before IV_{DD} must power up. The rise times on the power supplies should be slower than 50 V/millisecond to avoid turning on the internal ESD protection clamp diodes.

3.3.2 Power-Down Sequence

If IV_{DD}/PV_{DD} are powered down first, sense circuits in the I/O pads cause all output drivers to be in a high impedance state. There is no limit on how long after IV_{DD} and PV_{DD} power down before EV_{DD} or SDV_{DD} must power down. There are no requirements for the fall times of the power supplies.

4 Pin Assignments and Reset States

4.1 Signal Multiplexing

The following table lists all the MCF5445x pins grouped by function. The Dir column is the direction for the primary function of the pin only. Refer to [Section 4, “Pin Assignments and Reset States,”](#) for package diagrams. For a more detailed discussion of the MCF5445x signals, consult the *MCF54455 Reference Manual* (MCF54455RM).

NOTE

In this table and throughout this document, a single signal within a group is designated without square brackets (i.e., FB_AD23), while designations for multiple signals within a group use brackets (i.e., FB_AD[23:21]) and is meant to include all signals within the two bracketed numbers when these numbers are separated by a colon.

NOTE

The primary functionality of a pin is not necessarily its default functionality. Most pins that are muxed with GPIO default to their GPIO functionality. See [Table 3](#) for a list of the exceptions.

Table 3. Special-Case Default Signal Functionality

Pin	256 MAPBGA	360 TEPBGA
FB_AD[31:0]	FB_AD[31:0] except when serial boot selects 0-bit boot port size.	
FB_BE/BWE[3:0]	$\overline{FB_BE/BWE}$ [3:0]	
FB_CS[3:1]	$\overline{FB_CS}$ [3:1]	
FB_OE	$\overline{FB_OE}$	
FB_R/ \overline{W}	FB_R/ \overline{W}	
$\overline{FB_TA}$	$\overline{FB_TA}$	
$\overline{FB_TS}$	$\overline{FB_TS}$	

Table 3. Special-Case Default Signal Functionality (continued)

Pin	256 MAPBGA	360 TEPBGA
$\overline{\text{PCI_GNT}}[3:0]$	GPIO	$\overline{\text{PCI_GNT}}[3:0]$
$\overline{\text{PCI_REQ}}[3:0]$	GPIO	$\overline{\text{PCI_REQ}}[3:0]$
IRQ1	GPIO	$\overline{\text{PCI_INTA}}$ and configured as an agent.
ATA_RESET	GPIO	ATA reset

Table 4. MCF5445x Signal Information and Muxing

Signal Name	GPIO	Alternate 1	Alternate 2	Pull-up (U) ¹ Pull-down (D)	Direction ²	Voltage Domain	MCF54450 MCF54451 256 MAPBGA	MCF54452 MCF54453 MCF54454 MCF54455 360 TEPBGA
Reset								
$\overline{\text{RESET}}$	—	—	—	U	I	EVDD	L4	Y18
$\overline{\text{RSTOUT}}$	—	—	—	—	O	EVDD	M15	B17
Clock								
EXTAL/PCI_CLK	—	—	—	—	I	EVDD	M16	A16
XTAL	—	—	—	U ³	O	EVDD	L16	A17
Mode Selection								
BOOTMOD[1:0]	—	—	—	—	I	EVDD	M5, M7	AB17, AB21
FlexBus								
FB_AD[31:24]	PFBADH[7:0] ⁴	FB_D[31:24]	—	—	I/O	EVDD	A14, A13, D12, C12, B12, A12, D11, C11	J2, K4, J1, K1–3, L1, L4
FB_AD[23:16]	PFBADMH[7:0] ⁴	FB_D[23:16]	—	—	I/O	EVDD	B11, A11, D10, C10, B10, A10, D9, C9	L2, L3, M1–4, N1–2
FB_AD[15:8]	PFBADML[7:0] ⁴	FB_D[15:8]	—	—	I/O	EVDD	B9, A9, D8, C8, B8, A8, D7, C7	P1–2, R1–3, P4, T1–2
FB_AD[7:0]	PFBADL[7:0] ⁴	FB_D[7:0]	—	—	I/O	EVDD	B7, A7, D6, C6, B6, A6, D5, C5	T3–4, U1–3, V1–2, W1
$\overline{\text{FB_BE}}/\overline{\text{BWE}}[3:2]$	PBE[3:2]	FB_TSIZ[1:0]	—	—	O	EVDD	B5, A5	Y1, W2
$\overline{\text{FB_BE}}/\overline{\text{BWE}}[1:0]$	PBE[1:0]	—	—	—	O	EVDD	B4, A4	W3, Y2
FB_CLK	—	—	—	—	O	EVDD	B13	J3
$\overline{\text{FB_CS}}[3:1]$	PCS[3:1]	—	—	—	O	EVDD	C2, D4, C3	W5, AA4, AB3
$\overline{\text{FB_CS0}}$	—	—	—	—	O	EVDD	C4	Y4
$\overline{\text{FB_OE}}$	PFBCTL3	—	—	—	O	EVDD	A2	AA1
FB_R $\overline{\text{W}}$	PFBCTL2	—	—	—	O	EVDD	B2	AA3
$\overline{\text{FB_TA}}$	PFBCTL1	—	—	U	I	EVDD	B1	AB2

Table 4. MCF5445x Signal Information and Muxing (continued)

Signal Name	GPIO	Alternate 1	Alternate 2	Pull-up (U) ¹ Pull-down (D)	Direction ²	Voltage Domain	MCF54450 MCF54451 256 MAPBGA	MCF54452 MCF54453 MCF54454 MCF54455 360 TEPBGA
$\overline{\text{FB_TS}}$	PFBCTL0	FB_ALE	$\overline{\text{FB_TBST}}$	—	O	EVDD	A3	Y3
PCI Controller⁵								
PCI_AD[31:24]	—	FB_A[31:24]	—	—	I/O	EVDD	—	C11, D11, A10, B10, J4, G2, G3, F1
PCI_AD[23:0]	—	FB_A[23:0]	—	—	I/O	EVDD	K14–13, J15–13, H13–15, G15–13, F14–13, E15–13, D16, B16, C15, B15, C14, D15, C16, D14	D12, C12, B12, A11, B11, B9, D9, D10, A8, B8, A5, B5, A4, A3, B3, D4, D3, E3–E1, F3, C2, D2, C1
$\overline{\text{PCI_CBE}}[3:0]$	—	—	—	—	I/O	EVDD	—	G4, E4, D1, B1
$\overline{\text{PCI_DEVSEL}}$	—	—	—	—	O	EVDD	—	F2
$\overline{\text{PCI_FRAME}}$	—	—	—	—	I/O	EVDD	—	B2
PCI_GNT $\overline{3}$	PPCI7	$\overline{\text{ATA_DMACK}}$	—	—	O	EVDD	—	B7
PCI_GNT $\overline{[2:1]}$	PPCI[6:5]	—	—	—	O	EVDD	—	C8, C9
$\overline{\text{PCI_GNT0/}}/$ $\overline{\text{PCI_EXTREQ}}$	PPCI4	—	—	—	O	EVDD	—	A9
PCI_IDSEL	—	—	—	—	I	EVDD	—	D5
$\overline{\text{PCI_IRDY}}$	—	—	—	—	I/O	EVDD	—	C3
PCI_PAR	—	—	—	—	I/O	EVDD	—	C4
$\overline{\text{PCI_PERR}}$	—	—	—	—	I/O	EVDD	—	B4
$\overline{\text{PCI_REQ3}}$	PPCI3	ATA_INTRQ	—	—	I	EVDD	—	C7
$\overline{\text{PCI_REQ}}[2:1]$	PPCI[2:1]	—	—	—	I	EVDD	—	D7, C5
$\overline{\text{PCI_REQ0/}}/$ $\overline{\text{PCI_EXTGNT}}$	PPCI0	—	—	—	I	EVDD	—	A2
$\overline{\text{PCI_RST}}$	—	—	—	—	O	EVDD	—	B6
$\overline{\text{PCI_SERR}}$	—	—	—	—	I/O	EVDD	—	A6
$\overline{\text{PCI_STOP}}$	—	—	—	—	I/O	EVDD	—	A7
$\overline{\text{PCI_TRDY}}$	—	—	—	—	I/O	EVDD	—	C10
SDRAM Controller								
SD_A[13:0]	—	—	—	—	O	SDVDD	R1, P1, N2, P2, R2, T2, M4, N3, P3, R3, T3, T4, R4, N4	V22, U20–22, T19–22, R20–22, N19, P20–21
SD_BA[1:0]	—	—	—	—	O	SDVDD	P4, T5	P22, P19
$\overline{\text{SD_CAS}}$	—	—	—	—	O	SDVDD	T6	L19
SD_CKE	—	—	—	—	O	SDVDD	N5	N22

Table 4. MCF5445x Signal Information and Muxing (continued)

Signal Name	GPIO	Alternate 1	Alternate 2	Pull-up (U) ¹ Pull-down (D)	Direction ²	Voltage Domain	MCF54450 MCF54451 256 MAPBGA	MCF54452 MCF54453 MCF54454 MCF54455 360 TEPBGA
SD_CLK	—	—	—	—	O	SDVDD	T9	L22
$\overline{\text{SD_CLK}}$	—	—	—	—	O	SDVDD	T8	M22
$\overline{\text{SD_CS}}[1:0]$	—	—	—	—	O	SDVDD	P6, R6	L20, M20
SD_D[31:16]	—	—	—	—	I/O	SDVDD	N6, T7, N7, P7, R7, R8, P8, N8, N9, T10, R10, P10, N10, T11, R11, P11	L21, K22, K21, K20, J20, J19, J21, J22, H20, G22, G21, G20, G19, F22, F21, F20
SD_DM[3:2]	—	—	—	—	O	SDVDD	P9, N12	H21, E21
SD_DQS[3:2]	—	—	—	—	O	SDVDD	R9, N11	H22, E22
$\overline{\text{SD_RAS}}$	—	—	—	—	O	SDVDD	P5	N21
SD_VREF	—	—	—	—	I	SDVDD	M8	M21
$\overline{\text{SD_WE}}$	—	—	—	—	O	SDVDD	R5	N20
External Interrupts Port⁶								
$\overline{\text{IRQ7}}$	PIRQ7	—	—	—	I	EVDD	L1	ABB13
$\overline{\text{IRQ4}}$	PIRQ4	—	SSI_CLKIN	—	I	EVDD	L2	ABB13
$\overline{\text{IRQ3}}$	PIRQ3	—	—	—	I	EVDD	L3	AB14
$\overline{\text{IRQ1}}$	PIRQ1	PCI_INTA	—	—	I	EVDD	F15	C6
FEC0								
FEC0_MDC	PFECI2C3	—	—	—	O	EVDD	F3	AB8
FEC0_MDIO	PFECI2C2	—	—	—	I/O	EVDD	F2	Y7
FEC0_COL	PFEC0H4	—	ULPI_DATA7	—	I	EVDD	E1	AB7
FEC0_CRD	PFEC0H0	—	ULPI_DATA6	—	I	EVDD	F1	AA7
FEC0_RXCLK	PFEC0H3	—	ULPI_DATA1	—	I	EVDD	G1	AA8
FEC0_RXDV	PFEC0H2	FEC0_RMII_ CRS_DV	—	—	I	EVDD	G2	Y8
FEC0_RXD[3:2]	PFEC0L[3:2]	—	ULPI_DATA[5:4]	—	I	EVDD	G3, G4	AB9, Y9
FEC0_RXD1	PFEC0L1	FEC0_RMII_RXD1	—	—	I	EVDD	H1	W9
FEC0_RXD0	PFEC0H1	FEC0_RMII_RXD0	—	—	I	EVDD	H2	AB10
FEC0_RXER	PFEC0L0	FEC0_RMII_RXER	—	—	I	EVDD	H3	AA10
FEC0_TXCLK	PFEC0H7	FEC0_RMII_ REF_CLK	—	—	I	EVDD	H4	Y10
FEC0_TXD[3:2]	PFEC0L[7:6]	—	ULPI_DATA[3:2]	—	O	EVDD	J1, J2	W10, AB11
FEC0_TXD1	PFEC0L5	FEC0_RMII_TXD1	—	—	O	EVDD	J3	AA11

Table 4. MCF5445x Signal Information and Muxing (continued)

Signal Name	GPIO	Alternate 1	Alternate 2	Pull-up (U) ¹ Pull-down (D)	Direction ²	Voltage Domain	MCF54450 MCF54451 256 MAPBGA	MCF54452 MCF54453 MCF54454 MCF54455 360 TEPBGA
FEC0_TXD0	PFEC0H5	FEC0_RMII_TXD0	—	—	O	EVDD	J4	Y11
FEC0_TXEN	PFEC0H6	FEC0_RMII_TXEN	—	—	O	EVDD	K1	W11
FEC0_TXER	PFEC0L4	—	ULPI_DATA0	—	O	EVDD	K2	AB12
FEC1								
FEC1_MDC	PFEC12C5	—	ATA_DIOR	—	O	EVDD	—	W20
FEC1_MDIO	PFEC12C4	—	ATA_DIOW	—	I/O	EVDD	—	Y22
FEC1_COL	PFEC1H4	—	ATA_DATA7	—	I	EVDD	—	AB18
FEC1_CRS	PFEC1H0	—	ATA_DATA6	—	I	EVDD	—	AA18
FEC1_RXCLK	PFEC1H3	—	ATA_DATA5	—	I	EVDD	—	W14
FEC1_RXDV	PFEC1H2	FEC1_RMII_CRS_DV	ATA_DATA15	—	I	EVDD	—	AB15
FEC1_RXD[3:2]	PFEC1L[3:2]	—	ATA_DATA[4:3]	—	I	EVDD	—	AA15, Y15
FEC1_RXD1	PFEC1L1	FEC1_RMII_RXD1	ATA_DATA14	—	I	EVDD	—	AA17
FEC1_RXD0	PFEC1H1	FEC1_RMII_RXD0	ATA_DATA13	—	I	EVDD	—	Y17
FEC1_RXER	PFEC1L0	FEC1_RMII_RXER	ATA_DATA12	—	I	EVDD	—	W17
FEC1_TXCLK	PFEC1H7	FEC1_RMII_REF_CLK	ATA_DATA11	—	I	EVDD	—	AB19
FEC1_TXD[3:2]	PFEC1L[7:6]	—	ATA_DATA[2:1]	—	O	EVDD	—	Y19, W18
FEC1_TXD1	PFEC1L5	FEC1_RMII_TXD1	ATA_DATA10	—	O	EVDD	—	AA19
FEC1_TXD0	PFEC1H5	FEC1_RMII_TXD0	ATA_DATA9	—	O	EVDD	—	Y20
FEC1_TXEN	PFEC1H6	FEC1_RMII_TXEN	ATA_DATA8	—	O	EVDD	—	AA21
FEC1_TXER	PFEC1L4	—	ATA_DATA0	—	O	EVDD	—	AA22
USB On-the-Go								
USB_DM	—	—	—	—	O	USB VDD	F16	A14
USB_DP	—	—	—	—	O	USB VDD	E16	A15
USB_VBUS_EN	PUSB1	USB_PULLUP	ULPI_NXT	—	O	USB VDD	E5	AA2
USB_VBUS_OC	PUSB0	—	ULPI_STP	UD ⁷	I	USB VDD	B3	V4
ATA								
ATA_BUFFER_EN	PATAH5	—	—	—	O	EVDD	—	Y13
ATA_CS[1:0]	PATAH[4:3]	—	—	—	O	EVDD	—	W21, W22

Table 4. MCF5445x Signal Information and Muxing (continued)

Signal Name	GPIO	Alternate 1	Alternate 2	Pull-up (U) ¹ Pull-down (D)	Direction ²	Voltage Domain	MCF54450 MCF54451 256 MAPBGA	MCF54452 MCF54453 MCF54454 MCF54455 360 TEPBGA
ATA_DA[2:0]	PATAH[2:0]	—	—	—	O	EVDD	—	V19–21
$\overline{\text{ATA_RESET}}$	PATAL2	—	—	—	O	EVDD	—	W13
ATA_DMARQ	PATAL1	—	—	—	I	EVDD	—	AA14
ATA_IORDY	PATAL0	—	—	—	I	EVDD	—	Y14
Real Time Clock								
EXTAL32K	—	—	—	—	I	EVDD	J16	A13
XTAL32K	—	—	—	—	O	EVDD	H16	A12
SSI								
SSI_MCLK	PSSI4	—	—	—	O	EVDD	T13	D20
SSI_BCLK	PSSI3	$\overline{\text{U1CTS}}$	—	—	I/O	EVDD	R13	E19
SSI_FS	PSSI2	$\overline{\text{U1RTS}}$	—	—	I/O	EVDD	P12	E20
SSI_RXD	PSSI1	U1RXD	—	UD	I	EVDD	T12	D21
SSI_TXD	PSSI0	U1TXD	—	UD	O	EVDD	R12	D22
I²C								
I2C_SCL	PFECI2C1	—	U2TXD	U	I/O	EVDD	K3	AA12
I2C_SDA	PFECI2C0	—	U2RXD	U	I/O	EVDD	K4	Y12
DMA								
$\overline{\text{DACK1}}$	PDMA3	—	ULPI_DIR	—	O	EVDD	M14	C17
$\overline{\text{DREQ1}}$	PDMA2	—	USB_CLKIN	U	I	EVDD	P16	C18
$\overline{\text{DACK0}}$	PDMA1	DSPI_PCS3	—	—	O	EVDD	N15	A18
$\overline{\text{DREQ0}}$	PDMA0	—	—	U	I	EVDD	N16	B18
DSPI								
DSPI_PCS5/ $\overline{\text{PCSS}}$	PDSP16	—	—	—	O	EVDD	N14	D18
DSPI_PCS2	PDSP15	—	—	—	O	EVDD	L13	A19
DSPI_PCS1	PDSP14	$\overline{\text{SBF_CS}}$	—	—	O	EVDD	P14	B20
DSPI_PCS0/ $\overline{\text{SS}}$	PDSP13	—	—	U	I/O	EVDD	R16	D17
DSPI_SCK	PDSP12	SBF_CK	—	—	I/O	EVDD	R15	A20
DSPI_SIN	PDSP11	SBF_DI	—	⁸	I	EVDD	P15	B19
DSPI_SOUT	PDSP10	SBF_DO	—	—	O	EVDD	N13	C20

Table 4. MCF5445x Signal Information and Muxing (continued)

Signal Name	GPIO	Alternate 1	Alternate 2	Pull-up (U) ¹ Pull-down (D)	Direction ²	Voltage Domain	MCF54450 MCF54451 256 MAPBGA	MCF54452 MCF54453 MCF54454 MCF54455 360 TEPBGA
UARTs								
$\overline{U1CTS}$	PUART7	—	—	—	I	EVDD	—	V3
$\overline{U1RTS}$	PUART6	—	—	—	O	EVDD	—	U4
U1RXD	PUART5	—	—	—	I	EVDD	—	P3
U1TXD	PUART4	—	—	—	O	EVDD	—	N3
$\overline{U0CTS}$	PUART3	—	—	—	I	EVDD	M3	Y16
$\overline{U0RTS}$	PUART2	—	—	—	O	EVDD	M2	AA16
U0RXD	PUART1	—	—	—	I	EVDD	N1	AB16
U0TXD	PUART0	—	—	—	O	EVDD	M1	W15
Note: The UART1 and UART 2 signals are multiplexed on the DMA timers and I2C pins.								
DMA Timers								
DT3IN	PTIMER3	DT3OUT	U2RXD	—	I	EVDD	C13	H2
DT2IN	PTIMER2	DT2OUT	U2TXD	—	I	EVDD	D13	H1
DT1IN	PTIMER1	DT1OUT	$\overline{U2CTS}$	—	I	EVDD	B14	H3
DT0IN	PTIMER0	DT0OUT	$\overline{U2RTS}$	—	I	EVDD	A15	G1
BDM/JTAG⁹								
PSTDDATA[7:0]	—	—	—	—	O	EVDD	E2, D1, F4, E3, D2, C1, E4, D3	AA6, AB6, AB5, W6, Y6, AA5, AB4, Y5
JTAG_EN	—	—	—	D	I	EVDD	M11	C21
PSTCLK	—	TCLK	—	—	I	EVDD	P13	C22
DSI	—	TDI	—	U	I	EVDD	T15	C19
DSO	—	TDO	—	—	O	EVDD	T14	A21
\overline{BKPT}	—	TMS	—	U	I	EVDD	R14	B21
DSCLK	—	\overline{TRST}	—	U	I	EVDD	M13	B22
Test								
TEST	—	—	—	D	I	EVDD	M6	AB20
PLLTEST	—	—	—	—	O	EVDD	K16	D15

Table 4. MCF5445x Signal Information and Muxing (continued)

Signal Name	GPIO	Alternate 1	Alternate 2	Pull-up (U) ¹ Pull-down (D)	Direction ²	Voltage Domain	MCF54450 MCF54451 256 MAPBGA	MCF54452 MCF54453 MCF54454 MCF54455 360 TEPBGA
Power Supplies								
IVDD	—	—	—	—	—	—	E6–12, F5, F12	D6, D8, D14, F4, H4, N4, R4, W4, W7, W8, W12, W16, W19
EVDD	—	—	—	—	—	—	G5, G12, H5, H12, J5, J12, K5, K12, L5–6, L12	D13, D19, G8, G11, G14, G16, J7, J16, L7, L16, N16, P7, R16, T8, T12, T14, T16
SD_VDD	—	—	—	—	—	—	L7–11, M9, M10	F19, H19, K19, M19, R19, U19
VDD_OSC	—	—	—	—	—	—	L14	B16
VDD_A_PLL	—	—	—	—	—	—	K15	C14
VDD_RTC	—	—	—	—	—	—	M12	C13
VSS	—	—	—	—	—	—	A1, A16, F6–11, G6–11, H6–11, J6–11, K6–11, T1, T16	A1, A22, B14, G7, G9–10, G12–13, G15, H7, H16, J9–14, K7, K9–14, K16, L9–14, M7, M9–M14, M16, N9–14, P9–14, P16, R7, T7, T9–11, T13, T15, AB1, AB22
VSS_OSC	—	—	—	—	—	—	L15	C16

¹ Pull-ups are generally only enabled on pins with their primary function, except as noted.

² Refers to pin's primary function.

³ Enabled only in oscillator bypass mode (internal crystal oscillator is disabled).

⁴ Serial boot must select 0-bit boot port size to enable the GPIO mode on these pins.

⁵ When the PCI is enabled, all PCI bus pins come up configured as such. This includes the PCI_GNT and PCI_REQ lines, which have GPIO. The IRQ1/ $\overline{\text{PCI_INTA}}$ signal is a special case. It comes up as $\overline{\text{PCI_INTA}}$ when booting as a PCI agent and as GPIO when booting as a PCI host.

For the 360 TEPBGA, booting with PCI disabled results in all dedicated PCI pins being safe-stated. The $\overline{\text{PCI_GNT}}$ and $\overline{\text{PCI_REQ}}$ lines and IRQ1/ $\overline{\text{PCI_INTA}}$ come up as GPIO.

⁶ GPIO functionality is determined by the edge port module. The pin multiplexing and control module is only responsible for assigning the alternate functions.

⁷ Depends on programmed polarity of the USB_VBUS_OC signal.

⁸ Pull-up when the serial boot facility (SBF) controls the pin

⁹ If JTAG_EN is asserted, these pins default to Alternate 1 (JTAG) functionality. The pin multiplexing and control module is not responsible for assigning these pins.

4.2 Pinout—256 MAPBGA

The pinout for the MCF54450 and MCF54451 packages are shown below.

	1	2	3	4	5	6	7	8	9	10	11	12	13	14	15	16		
A	VSS	FB_OE	FB_TS	FB_BE/BWE0	FB_BE/BWE2	FB_AD 2	FB_AD 6	FB_AD 10	FB_AD 14	FB_AD 18	FB_AD 22	FB_AD 26	FB_AD 30	FB_AD 31	T0IN	VSS	A	
B	FB_TA	FB_R/W	USB_VBUS_OC	FB_BE/BWE1	FB_BE/BWE3	FB_AD 3	FB_AD 7	FB_AD 11	FB_AD 15	FB_AD 19	FB_AD 23	FB_AD 27	FB_CLK	T1IN	PCI_AD 4	PCI_AD 6	B	
C	PST_DDATA2	FB_CS3	FB_CS1	FB_CS0	FB_AD 0	FB_AD 4	FB_AD 8	FB_AD 12	FB_AD 16	FB_AD 20	FB_AD 24	FB_AD 28	T3IN	PCI_AD 3	PCI_AD 5	PCI_AD 1	C	
D	PST_DDATA6	PST_DDATA3	PST_DDATA0	FB_CS2	FB_AD 1	FB_AD 5	FB_AD 9	FB_AD 13	FB_AD 17	FB_AD 21	FB_AD 25	FB_AD 29	T2IN	PCI_AD 0	PCI_AD 2	PCI_AD 7	D	
E	FEC0_COL	PST_DDATA7	PST_DDATA4	PST_DDATA1	USB_VBUS_EN	IVDD	IVDD	IVDD	IVDD	IVDD	IVDD	IVDD	IVDD	PCI_AD 8	PCI_AD 9	PCI_AD 10	USB_DP	E
F	FEC0_CRS	FEC0_MDIO	FEC0_MDC	PST_DDATA5	IVDD	VSS	VSS	VSS	VSS	VSS	VSS	VSS	IVDD	PCI_AD 11	PCI_AD 12	IRQ_1	USB_DM	F
G	FEC0_RXCLK	FEC0_RXDV	FEC0_RXD3	FEC0_RXD2	EVDD	VSS	VSS	VSS	VSS	VSS	VSS	VSS	EVDD	PCI_AD 13	PCI_AD 14	PCI_AD 15	NC	G
H	FEC0_RXD1	FEC0_RXD0	FEC0_RXER	FEC0_TXCLK	EVDD	VSS	VSS	VSS	VSS	VSS	VSS	VSS	EVDD	PCI_AD 18	PCI_AD 17	PCI_AD 16	XTAL 32K	H
J	FEC0_TXD3	FEC0_TXD2	FEC0_TXD1	FEC0_TXD0	EVDD	VSS	VSS	VSS	VSS	VSS	VSS	VSS	EVDD	PCI_AD 19	PCI_AD 20	PCI_AD 21	EXTAL 32K	J
K	FEC0_TXEN	FEC0_TXER	I2C_SCL	I2C_SDA	EVDD	VSS	VSS	VSS	VSS	VSS	VSS	VSS	EVDD	PCI_AD 22	PCI_AD 23	VDD_A_PLL	PLL TEST	K
L	IRQ_7	IRQ_4	IRQ_3	RESET	EVDD	EVDD	SDVDD	SDVDD	SDVDD	SDVDD	SDVDD	SDVDD	EVDD	DSPI_PCS2	VDD_OSC	VSS_OSC	XTAL	L
M	U0TXD	U0RTS	U0CTS	SD_A7	BOOT_MOD1	TEST	BOOT_MOD0	SD_VREF	SDVDD	SDVDD	JTAG_EN	VDD_RTC	TRST	DACK1	RST_OUT	EXTAL	M	
N	U0RXD	SD_A11	SD_A6	SD_A0	SD_CKE	SD_D31	SD_D29	SD_D24	SD_D23	SD_D19	SD_DQS2	SD_DM2	DSPI_SOUT	DSPI_PCS5	DACK0	DREQ0	N	
P	SD_A12	SD_A10	SD_A5	SD_BA1	SD_RAS	SD_CS1	SD_D28	SD_D25	SD_DM3	SD_D20	SD_D16	SSI_FS	TCLK	DSPI_PCS1	DSPI_SIN	DREQ1	P	
R	SD_A13	SD_A9	SD_A4	SD_A1	SD_WE	SD_CS0	SD_D27	SD_D26	SD_DQS3	SD_D21	SD_D17	SSI_TXD	SSI_BCLK	TMS	DSPI_SCK	DSPI_PCS0	R	
T	VSS	SD_A8	SD_A3	SD_A2	SD_BA0	SD_CAS	SD_D30	SD_CLK	SD_CLK	SD_D22	SD_D18	SSI_RXD	SSI_MCLK	TDO	TDI	VSS	T	

Figure 5. MCF54450 and MCF54451 Pinout (256 MAPBGA)

4.3 Pinout—360 TEPBGA

The pinout for the MCF54452, MCF54453, MCF54454, and MCF54455 packages are shown below.

	1	2	3	4	5	6	7	8	9	10	11	12	13	14	15	16	17	18	19	20	21	22		
A	GND	PCI_REQ0	PCI_AD10	PCI_AD11	PCI_AD13	PCI_SERR	PCI_STOP	PCI_AD15	PCI_GNT0	PCI_AD29	PCI_AD20	XTAL_32K	EXTAL_32K	USB_DM	USB_DP	EXTAL	XTAL	DACK0	DSPL_PCS2	DSPL_SCK	TDO	GND	A	
B	PCI_CBE0	PCI_FRAME	PCI_AD9	PCI_PERR	PCI_AD12	PCI_RST	PCI_GNT3	PCI_AD14	PCI_AD18	PCI_AD28	PCI_AD19	PCI_AD21	NC	GND	NC	VDD_OSC	RST_OUT	DREQ0	DSPL_SIN	DSPL_PCS1	TMS	TRST	B	
C	PCI_AD0	PCI_AD2	PCI_IRDY	PCI_PAR	PCI_REQ1	IRQT	PCI_REQ3	PCI_GNT2	PCI_GNT1	PCI_TRDY	PCI_AD31	PCI_AD22	VDD_RTC	VDD_A_PLL	NC	VSS_OSC	DACKT	DREQT	TDI	DSPL_SOUT	JTAG_EN	TCLK	C	
D	PCI_CBE1	PCI_AD1	PCI_AD7	PCI_AD8	PCI_IDSEL	IVDD	PCI_REQ2	IVDD	PCI_AD17	PCI_AD16	PCI_AD30	PCI_AD23	EVDD	IVDD	PLL_TEST	NC	DSPL_PCS0	DSPL_PCS5	EVDD	SSI_MCLK	SSI_RXD	SSI_TXD	D	
E	PCI_AD4	PCI_AD5	PCI_AD6	PCI_CBE2															SSI_BCLK	SSI_FS	SD_DM2	SD_DQS2	E	
F	PCI_AD24	PCI_DE_VSEL	PCI_AD3	IVDD															SDVDD	SD_D16	SD_D17	SD_D18	F	
G	T0IN	PCI_AD26	PCI_AD25	PCI_CBE3																SD_D19	SD_D20	SD_D21	SD_D22	G
H	T2IN	T3IN	T1IN	IVDD																SDVDD	SD_D23	SD_DM3	SD_DQS3	H
J	FB_AD_29	FB_AD_31	FB_CLK	PCI_AD27																SD_D26	SD_D27	SD_D25	SD_D24	J
K	FB_AD_28	FB_AD_27	FB_AD_26	FB_AD_30																SDVDD	SD_D28	SD_D29	SD_D30	K
L	FB_AD_25	FB_AD_23	FB_AD_22	FB_AD_24																SD_CAS	SD_CST	SD_D31	SD_CLK	L
M	FB_AD_21	FB_AD_20	FB_AD_19	FB_AD_18																SDVDD	SD_CS0	SD_VREF	SD_CLK	M
N	FB_AD_17	FB_AD_16	U1TXD	IVDD																SD_A2	SD_WE	SD_RAS	SD_CKE	N
P	FB_AD_15	FB_AD_14	U1RXD	FB_AD_10																SD_BA0	SD_A1	SD_A0	SD_BA1	P
R	FB_AD_13	FB_AD_12	FB_AD_11	IVDD																SDVDD	SD_A5	SD_A4	SD_A3	R
T	FB_AD_9	FB_AD_8	FB_AD_7	FB_AD_6																SD_A9	SD_A8	SD_A7	SD_A6	T
U	FB_AD_5	FB_AD_4	FB_AD_3	U1RTS																SDVDD	SD_A12	SD_A11	SD_A10	U
V	FB_AD_2	FB_AD_1	U1CTS	USB_VBUS_OC																ATA_DA2	ATA_DA1	ATA_DA0	SD_A13	V
W	FB_AD_0	FB_BE/BWE2	FB_BE/BWE1	IVDD	FB_CS3	PST_DDATA4	IVDD	IVDD	FEC0_RXD1	FEC0_TXD3	FEC0_TXEN	IVDD	ATA_RESET	FEC1_RXCLK	U0TXD	IVDD	FEC1_RXER	FEC1_TXD2	IVDD	FEC1_MDC	ATA_CST	ATA_CS0	W	
Y	FB_BE/BWE3	FB_BE/BWE0	FB_TS	FB_CS0	PST_DDATA0	PST_DDATA3	FEC0_MDIO	FEC0_RXDV	FEC0_RXD2	FEC0_TXCLK	FEC0_TXD0	I2C_SDA	ATA_BUFFER_EN	ATA_IORDY	FEC1_RXD2	U0CTS	FEC1_RXD0	RESET	FEC1_TXD3	FEC1_TXD0	NC	FEC1_MDIO	Y	
AA	FB_OE	USB_VBUS_EN	FB_RW	FB_CS2	PST_DDATA2	PST_DDATA7	FEC0_CRS	FEC0_RXCLK	NC	FEC0_RXER	FEC0_TXD1	I2C_SCL	IRQ4	ATA_DMARQ	FEC1_RXD3	U0RTS	FEC1_RXD1	FEC1_CRS	FEC1_TXD1	NC	FEC1_TXEN	FEC1_TXER	AA	
AB	GND	FB_TA	FB_CST	PST_DDATA1	PST_DDATA5	PST_DDATA6	FEC0_COL	FEC0_MDC	FEC0_RXD3	FEC0_RXD0	FEC0_TXD2	FEC0_TXER	IRQ7	IRQ3	FEC1_RXDV	U0RXD	BOOT_MOD1	FEC1_COL	FEC1_TXCLK	TEST	BOOT_MOD0	GND	AB	

Figure 6. MCF54452, MCF54453, MCF54454, and MCF54455 Pinout (360 TEPBGA)

5 Electrical Characteristics

This document contains electrical specification tables and reference timing diagrams for the MCF54455 microprocessor. This section contains detailed information on DC/AC electrical characteristics and AC timing specifications.

The electrical specifications are preliminary and from previous designs or design simulations. These specifications may not be fully tested or guaranteed at this early stage of the product life cycle. However, for production silicon, these specifications will be met. Finalized specifications will be published after complete characterization and device qualifications have been completed.

NOTE

The parameters specified in this MCU document supersede any values found in the module specifications.

5.1 Absolute Maximum Ratings

Table 5. Absolute Maximum Ratings^{1, 2}

Rating	Symbol	Pin Name	Value	Units
External I/O pad supply voltage	EV_{DD}	EVDD	-0.3 to +4.0	V
Internal oscillator supply voltage	$OSCV_{DD}$	VDD_OSC	-0.3 to +4.0	V
Real-time clock supply voltage	$RTCV_{DD}$	VDD_RTC	-0.5 to +2.0	V
Internal logic supply voltage	IV_{DD}	IVDD	-0.5 to +2.0	V
SDRAM I/O pad supply voltage	SDV_{DD}	SD_VDD	-0.3 to +4.0	V
PLL supply voltage	PV_{DD}	VDD_A_PLL	-0.5 to +2.0	V
Digital input voltage ³	V_{IN}	—	-0.3 to +3.6	V
Instantaneous maximum current Single pin limit (applies to all pins) ^{3, 4, 5}	I_{DD}	—	25	mA
Operating temperature range (packaged)	T_A ($T_L - T_H$)	—	-40 to +85	°C
Storage temperature range	T_{stg}	—	-55 to +150	°C

¹ Functional operating conditions are given in Table 8. Absolute maximum ratings are stress ratings only, and functional operation at the maximum is not guaranteed. Continued operation at these levels may affect device reliability or cause permanent damage to the device.

² This device contains circuitry protecting against damage due to high static voltage or electrical fields. However, it is advised that normal precautions be taken to avoid application of any voltages higher than maximum-rated voltages to this high-impedance circuit. Reliability of operation is enhanced if unused inputs are tied to an appropriate logic voltage level (e.g., V_{SS} or EV_{DD}).

³ Input must be current limited to the value specified. To determine the value of the required current-limiting resistor, calculate resistance values for positive and negative clamp voltages, and then use the larger of the two values.

⁴ All functional non-supply pins are internally clamped to V_{SS} and EV_{DD} .

⁵ Power supply must maintain regulation within operating EV_{DD} range during instantaneous and operating maximum current conditions. If positive injection current ($V_{in} > EV_{DD}$) is greater than I_{DD} , the injection current may flow out of EV_{DD} and could result in external power supply going out of regulation. Ensure the external EV_{DD} load shunts current greater than maximum injection current. This is the greatest risk when the MPU is not consuming power (ex; no clock). The power supply must maintain regulation within operating EV_{DD} range during instantaneous and operating maximum current conditions.

5.2 Thermal Characteristics

Table 6. Thermal Characteristics

Characteristic		Symbol	256MAPBGA	360PBGA	Unit
Junction to ambient, natural convection	Four layer board (2s2p)	θ_{JA}	29 ^{1,2}	24 ^{1,2}	°C/W
Junction to ambient (@200 ft/min)	Four layer board (2s2p)	θ_{JMA}	25 ^{1,2}	21 ^{1,2}	°C/W
Junction to board		θ_{JB}	18 ³	15 ³	°C/W
Junction to case		θ_{JC}	10 ⁴	11 ⁴	°C/W
Junction to top of package		Ψ_{jt}	2 ^{1,5}	2 ^{1,5}	°C/W
Maximum operating junction temperature		T_j	105	105	°C

¹ θ_{JMA} and Ψ_{jt} parameters are simulated in conformance with EIA/JESD Standard 51-2 for natural convection. Freescale recommends the use of θ_{JMA} and power dissipation specifications in the system design to prevent device junction temperatures from exceeding the rated specification. System designers should be aware that device junction temperatures can be significantly influenced by board layout and surrounding devices. Conformance to the device junction temperature specification can be verified by physical measurement in the customer's system using the Ψ_{jt} parameter, the device power dissipation, and the method described in EIA/JESD Standard 51-2.

² Per JEDEC JESD51-6 with the board horizontal.

³ Thermal resistance between the die and the printed circuit board in conformance with JEDEC JESD51-8. Board temperature is measured on the top surface of the board near the package.

⁴ Thermal resistance between the die and the case top surface as measured by the cold plate method (MIL SPEC-883 Method 1012.1).

⁵ Thermal characterization parameter indicating the temperature difference between package top and the junction temperature per JEDEC JESD51-2. When Greek letters are not available, the thermal characterization parameter is written in conformance with Psi-JT.

The average chip-junction temperature (T_j) in °C can be obtained from:

$$T_j = T_A + (P_D \times \theta_{JMA}) \quad \text{Eqn. 1}$$

Where:

T_A	= Ambient Temperature, °C
θ_{JMA}	= Package Thermal Resistance, Junction-to-Ambient, °C/W
P_D	= $P_{INT} + P_{I/O}$
P_{INT}	= $I_{DD} \times IV_{DD}$, Watts - Chip Internal Power
$P_{I/O}$	= Power Dissipation on Input and Output Pins - User Determined

For most applications $P_{I/O} < P_{INT}$ and can be ignored. An approximate relationship between P_D and T_j (if $P_{I/O}$ is neglected) is:

$$P_D = \frac{K}{(T_j + 273^\circ C)} \quad \text{Eqn. 2}$$

Solving equations 1 and 2 for K gives:

$$K = P_D \times (T_A + 273^\circ C) + \theta_{JMA} \times P_D^2 \quad \text{Eqn. 3}$$

where K is a constant pertaining to the particular part. K can be determined from Equation 3 by measuring P_D (at equilibrium) for a known T_A . Using this value of K, the values of P_D and T_J can be obtained by solving Equation 1 and Equation 2 iteratively for any value of T_A .

5.3 ESD Protection

Table 7. ESD Protection Characteristics^{1, 2}

Characteristics	Symbol	Value	Units
ESD Target for Human Body Model	HBM	2000	V

¹ All ESD testing is in conformity with CDF-AEC-Q100 Stress Test Qualification for Automotive Grade Integrated Circuits.

² A device is defined as a failure if after exposure to ESD pulses the device no longer meets the device specification requirements. Complete DC parametric and functional testing is performed per applicable device specification at room temperature followed by hot temperature, unless specified otherwise in the device specification.

5.4 DC Electrical Specifications

Table 8. DC Electrical Specifications

Characteristic	Symbol	Min	Max	Units
Internal logic supply voltage ¹	V_{DD}	1.35	1.65	V
PLL analog operation voltage range ¹	PV_{DD}	1.35	1.65	V
External I/O pad supply voltage	EV_{DD}	3.0	3.6	V
Internal oscillator supply voltage	$OSCV_{DD}$	3.0	3.6	V
Real-time clock supply voltage	$RTCV_{DD}$	1.35	1.65	V
SDRAM I/O pad supply voltage — DDR mode	SDV_{DD}	2.25	2.75	V
SDRAM I/O pad supply voltage — DDR2 mode	SDV_{DD}	1.7	1.9	V
SDRAM I/O pad supply voltage — Mobile DDR mode	SDV_{DD}	1.7	1.9	V
SDRAM input reference voltage	SDV_{REF}	$0.49 \times SDV_{DD}$	$0.51 \times SDV_{DD}$	V
Input High Voltage	V_{IH}	$0.7 \times EV_{DD}$	3.65	V
Input Low Voltage	V_{IL}	$V_{SS} - 0.3$	$0.35 \times EV_{DD}$	V
Input Hysteresis	V_{HYS}	$0.06 \times EV_{DD}$	—	mV
Input Leakage Current $V_{in} = V_{DD}$ or V_{SS} , Input-only pins	I_{in}	-1.0	1.0	μA
High Impedance (Off-State) Leakage Current ² $V_{in} = V_{DD}$ or V_{SS} , All input/output and output pins	I_{OZ}	-10.0	10.0	μA
Output High Voltage (All input/output and all output pins) $I_{OH} = -5.0$ mA	V_{OH}	$0.85 \times EV_{DD}$	—	V
Output Low Voltage (All input/output and all output pins) $I_{OL} = 5.0$ mA	V_{OL}	—	$0.15 \times EV_{DD}$	V

Table 8. DC Electrical Specifications

Characteristic	Symbol	Min	Max	Units
Weak Internal Pull Up Device Current, tested at V_{IL} Max. ³	I_{APU}	-10	-130	μ A
Input Capacitance ⁴ All input-only pins All input/output (three-state) pins	C_{in}	— —	7 7	pF
Load Capacitance Low drive strength High drive strength	C_L		25 50	pF
DC Injection Current ^{3, 5, 6, 7} $V_{NEGCLAMP} = V_{SS} - 0.3$ V, $V_{POSCLAMP} = V_{DD} + 0.3$ Single Pin Limit Total MCU Limit, Includes sum of all stressed pins	I_{IC}	-1.0 -10	1.0 10	mA

¹ $I_{V_{DD}}$ and PV_{DD} should be at the same voltage. PV_{DD} should have a filtered input. Please see the PLL section of this specification for an example circuit. There are three PV_{DD} inputs, one for each PLL. A filter circuit should be used on each PV_{DD} input.

² Worst-case tristate leakage current with only one I/O pin high. Since all I/Os share power when high, the leakage current is distributed among them. With all I/Os high, this spec reduces to ± 2 μ A min/max.

³ Refer to the *MCF54455 Reference Manual* signals description chapter for pins having weak internal pull-up devices.

⁴ This parameter is characterized before qualification rather than 100% tested.

⁵ All functional non-supply pins are internally clamped to V_{SS} and their respective V_{DD} .

⁶ Input must be current limited to the value specified. To determine the value of the required current-limiting resistor, calculate resistance values for positive and negative clamp voltages, then use the larger of the two values.

⁷ Power supply must maintain regulation within operating V_{DD} range during instantaneous and operating maximum current conditions. If positive injection current ($V_{in} > V_{DD}$) is greater than I_{DD} , the injection current may flow out of V_{DD} and could result in external power supply going out of regulation. Ensure the external V_{DD} load shunts current greater than the maximum injection current. This is the greatest risk when the MCU is not consuming power. Examples are: if no system clock is present, or if clock rate is very low which would reduce overall power consumption. Also, at power-up, the system clock is not present during the power-up sequence until the PLL has attained lock.

5.5 Clock Timing Specifications

The clock module configures the device for one of several clocking methods. Clocking modes include internal phase-locked loop (PLL) clocking with an external clock reference or an external crystal reference supported by an internal crystal amplifier. The PLL can also be disabled, and an external oscillator can directly clock the device.

The specifications in Table 9 are for the CLKIN input pin (EXTAL input driven by an external clock reference). The duty cycle specification is based on an acceptable tolerance for the PLL, which yields 50% duty-cycle internal clocks to all on-chip peripherals. The MCF5445x devices use the input clock signal as its synchronous bus clock for PCI. A poor duty cycle on the input clock, may affect the overall timing margin to external devices. If negative edge logic is used to interface to PCI, providing a 50% duty-cycle input clock aids in simplifying overall system design.

Table 9. Input Clock Timing Requirements

Item	Specification	Min	Max	Unit
C1	Cycle time	15	40	ns

Table 9. Input Clock Timing Requirements (continued)

Item	Specification	Min	Max	Unit
1 / C1	Frequency	25	66.66	MHz
C2	Rise time (20% of vdd to 80% of vdd)	-	2	ns
C3	Fall time (80% of vdd to 20% of vdd)	-	2	ns
C4	Duty cycle (at 50% of vdd)	40	60	%

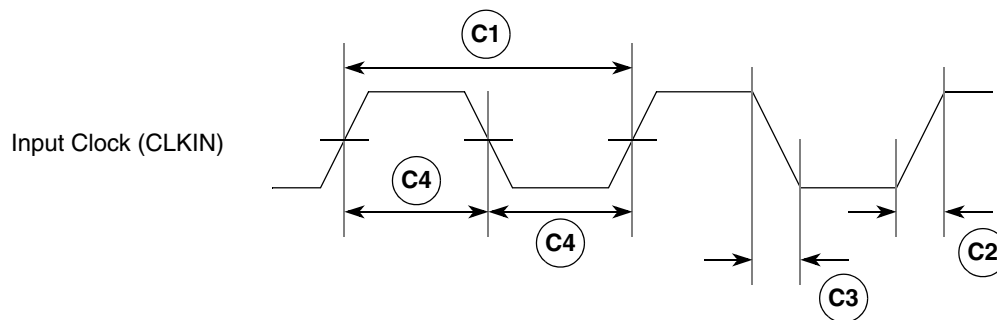

Figure 7. Input Clock Timing Diagram

Table 10. PLL Electrical Characteristics

Num	Characteristic	Symbol	Min. Value	Max. Value	Unit
1	PLL Reference Frequency Range				
	Crystal reference	$f_{ref_crystal}$	16	40	MHz
	External reference	f_{ref_ext}	16	66.66	MHz
2	Core/System Frequency	f_{sys}	512 Hz ¹	266.67 MHz	—
	Core/System Clock Period	t_{sys}	—	$1/f_{sys}$	ns
19	VCO Frequency ($f_{vco} = f_{ref} \times PFDR$)	f_{vco}	300	540	MHz
3	Crystal Start-up Time ^{2, 3}	t_{cst}	—	10	ms
4	EXTAL Input High Voltage				
	Crystal Mode ⁴	V_{IHEXT}	$V_{XTAL} + 0.4$	—	V
	All other modes (External, Limp)	V_{IHEXT}	$E_{VDD}/2 + 0.4$	—	V
5	EXTAL Input Low Voltage				
	Crystal Mode ⁴	V_{ILEXT}	—	$V_{XTAL} - 0.4$	V
	All other modes (External, Limp)	V_{ILEXT}	—	$E_{VDD}/2 - 0.4$	V
6	EXTAL Input Rise & Fall Time (20% to 80% E_{VDD}) (External, Limp)		1	2	ns
7	PLL Lock Time ^{3, 5}	t_{ppll}	—	50000	CLKIN
8	Duty Cycle of reference ³ (External, Limp)	t_{dc}	40	60	%
9	XTAL Current	I_{XTAL}	1	3	mA
10	Total on-chip stray capacitance on XTAL	C_{S_XTAL}	—	1.5	pF
11	Total on-chip stray capacitance on EXTAL	C_{S_EXTAL}	—	1.5	pF

Table 10. PLL Electrical Characteristics (continued)

Num	Characteristic	Symbol	Min. Value	Max. Value	Unit
12	Crystal capacitive load	C_L	See crystal spec		
13	Discrete load capacitance for XTAL Discrete load capacitance for EXTAL	C_{L_XTAL} C_{L_EXTAL}	—	$2 \times (C_L - C_{S_XTAL} - C_{S_EXTAL} - C_{S_PCB})^6$	pF
14	Frequency un-LOCK Range	f_{UL}	-4.0	4.0	% f_{sys}
15	Frequency LOCK Range	f_{LCK}	-2.0	2.0	% f_{sys}
17	CLKOUT Period Jitter, ^{3, 4, 7} Measured at f_{sys} Max Peak-to-peak Jitter (Clock edge to clock edge) Long Term Jitter	C_{jitter}	— —	10 TBD	% FB_CLK % FB_CLK

¹ The minimum system frequency is the minimum input clock divided by the maximum low-power divider (16 MHz ÷ 32,768). When the PLL is enabled, the minimum system frequency (f_{sys}) is 150 MHz.

² This parameter is guaranteed by characterization before qualification rather than 100% tested. Applies to external clock reference only.

³ Proper PC board layout procedures must be followed to achieve specifications.

⁴ This parameter is guaranteed by design rather than 100% tested.

⁵ This specification is the PLL lock time only and does not include oscillator start-up time.

⁶ C_{S_PCB} is the measured PCB stray capacitance on EXTAL and XTAL.

⁷ Jitter is the average deviation from the programmed frequency measured over the specified interval at maximum f_{sys} . Measurements are made with the device powered by filtered supplies and clocked by a stable external clock signal. Noise injected into the PLL circuitry via PLL V_{DD} , EV_{DD} , and V_{SS} and variation in crystal oscillator frequency increase the C_{jitter} percentage for a given interval.

5.6 Reset Timing Specifications

Table 11 lists specifications for the reset timing parameters shown in Figure 8.

Table 11. Reset and Configuration Override Timing

Num	Characteristic	Min	Max	Unit
R1 ¹	\overline{RESET} valid to CLKIN (setup)	9	—	ns
R2	CLKIN to \overline{RESET} invalid (hold)	1.5	—	ns
R3	\overline{RESET} valid time ²	5	—	CLKIN cycles
R4	CLKIN to \overline{RSTOUT} valid	—	10	ns
R5	\overline{RSTOUT} valid to Configuration Override inputs valid	0	—	ns
R6	Configuration Override inputs valid to \overline{RSTOUT} invalid (setup)	20	—	CLKIN cycles
R7	Configuration Override inputs invalid after \overline{RSTOUT} invalid (hold)	0	—	ns
R8	\overline{RSTOUT} invalid to Configuration Override inputs High Impedance	—	1	CLKIN cycles

¹ \overline{RESET} and Configuration Override data lines are synchronized internally. Setup and hold times must be met only if recognition on a particular clock is required.

² During low power STOP, the synchronizers for the \overline{RESET} input are bypassed and \overline{RESET} is asserted asynchronously to the system. Thus, \overline{RESET} must be held a minimum of 100 ns.

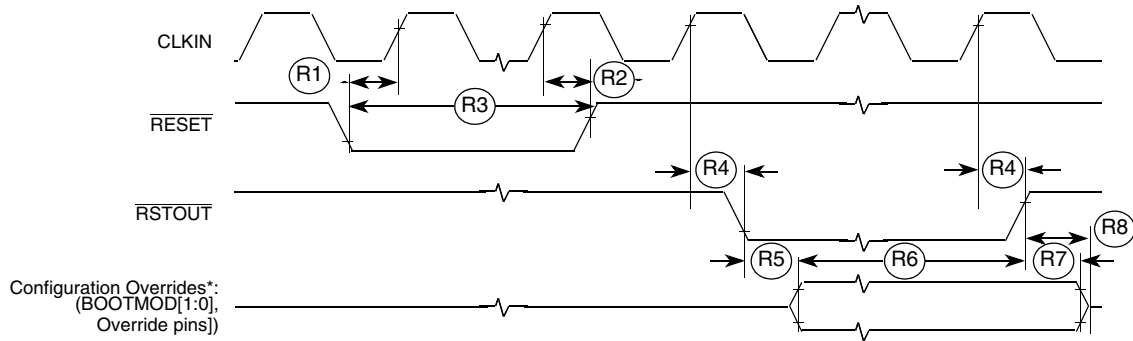
Figure 8. $\overline{\text{RESET}}$ and Configuration Override Timing

5.7 FlexBus Timing Specifications

A multi-function external bus interface called FlexBus is provided with basic functionality to interface to slave-only devices up to a maximum bus frequency of 66MHz. It can be directly connected to asynchronous or synchronous devices such as external boot ROMs, flash memories, gate-array logic, or other simple target (slave) devices with little or no additional circuitry. For asynchronous devices, a simple chip-select based interface can be used.

All processor bus timings are synchronous; input setup/hold and output delay are given in respect to the rising edge of a reference clock, FB_CLK. The FB_CLK frequency may be the same as the internal system bus frequency or an integer divider of that frequency.

The following timing numbers indicate when data is latched or driven onto the external bus, relative to the Flexbus output clock (FB_CLK). All other timing relationships can be derived from these values.

Table 12. FlexBus AC Timing Specifications

Num	Characteristic	Min	Max	Unit	Notes
	Frequency of Operation	25	66.66	MHz	
FB1	Clock Period	15	40	ns	
FB2	Output Valid	—	7.0	ns	¹
FB3	Output Hold	1.0	—	ns	1
FB4	Input Setup	3.0	—	ns	²
FB5	Input Hold	0	—	ns	2

¹ Specification is valid for all FB_AD[31:0], FB_BS[3:0], $\overline{\text{FB_CS}}$ [3:0], FB_OE, FB_R/W, FB_TBST, FB_TSIZ[1:0], and $\overline{\text{FB_TS}}$.

² Specification is valid for all FB_AD[31:0] and $\overline{\text{FB_TA}}$.

NOTE

The processor drives the data lines during the first clock cycle of the transfer with the full 32-bit address. This may be ignored by standard connected devices using non-multiplexed address and data buses. However, some applications may find this feature beneficial.

The address and data busses are muxed between the FlexBus and PCI controller. At the end of the read and write bus cycles the address signals are indeterminate.

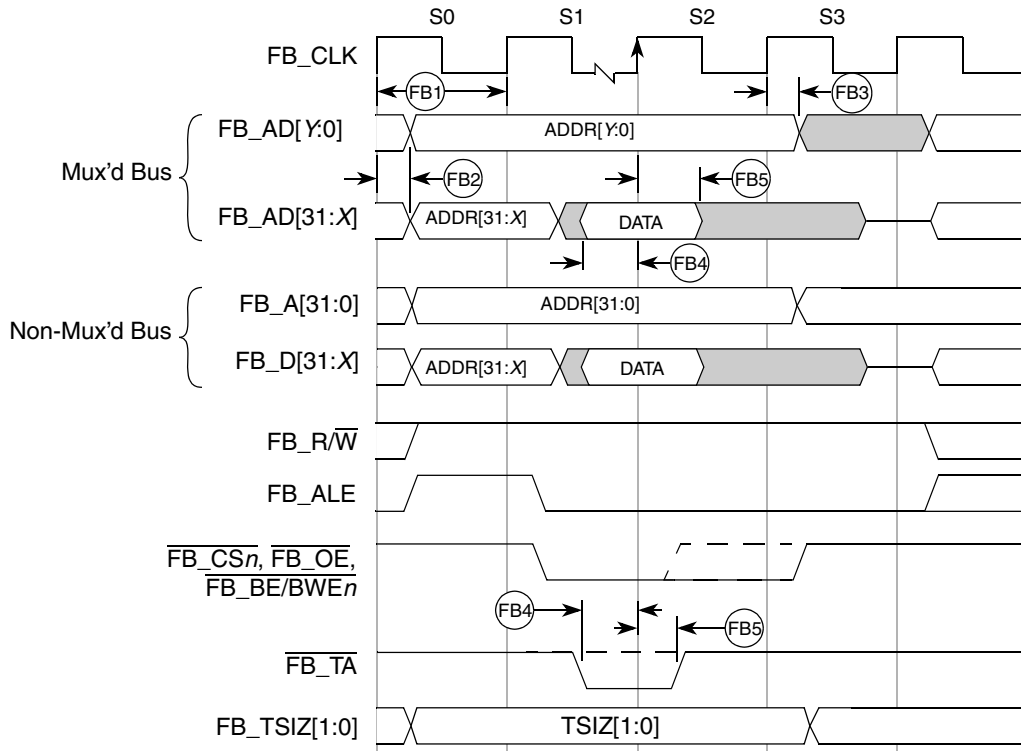

Figure 9. FlexBus Read Timing

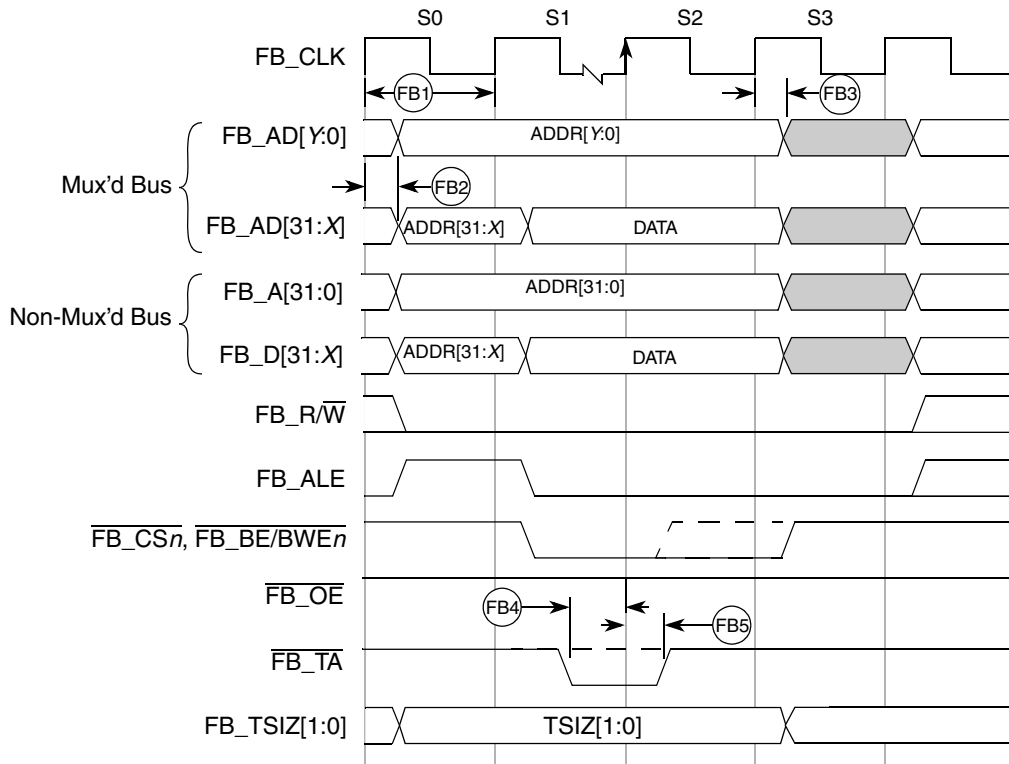

Figure 10. Flexbus Write Timing

5.8 SDRAM AC Timing Characteristics

The following timing numbers must be followed to properly latch or drive data onto the SDRAM memory bus. All timing numbers are relative to the four DQS byte lanes.

Table 13. SDRAM Timing Specifications

Num	Characteristic	Symbol	Min	Max	Unit	Notes
	Frequency of Operation		—	133.33	MHz	1
DD1	Clock Period	t_{SDCK}	7.5	—	ns	
DD2	Pulse Width High	t_{SDCKH}	0.45	0.55	t_{SDCK}	2
DD3	Pulse Width Low	t_{SDCKL}	0.45	0.55	t_{SDCK}	3
DD4	Address, $\overline{SD_CKE}$, $\overline{SD_CAS}$, $\overline{SD_RAS}$, $\overline{SD_WE}$, $\overline{SD_CS}[1:0]$ — Output Valid	t_{CMV}	—	$(0.5 \times t_{SDCK}) + 1.0\text{ns}$	ns	3
DD5	Address, $\overline{SD_CKE}$, $\overline{SD_CAS}$, $\overline{SD_RAS}$, $\overline{SD_WE}$, $\overline{SD_CS}[1:0]$ — Output Hold	t_{CMH}	2.0	—	ns	
DD6	Write Command to first DQS Latching Transition	t_{DQSS}	$(1.0 \times t_{SDCK}) - 0.6\text{ns}$	$(1.0 \times t_{SDCK}) + 0.6\text{ns}$	ns	
DD7	Data and Data Mask Output Setup (DQ-->DQS) Relative to DQS (DDR Write Mode)	t_{QS}	1.0	—	ns	4 5
DD8	Data and Data Mask Output Hold (DQS-->DQ) Relative to DQS (DDR Write Mode)	t_{QH}	1.0	—	ns	6
DD9	Input Data Skew Relative to DQS (Input Setup)	t_{IS}	—	1.0	ns	7
DD10	Input Data Hold Relative to DQS.	t_{IH}	$(0.25 \times t_{SDCK}) + 0.5\text{ns}$	—	ns	8

¹ The SDRAM interface operates at the same frequency as the internal system bus.

² Pulse width high plus pulse width low cannot exceed min and max clock period.

³ Command output valid should be 1/2 the memory bus clock (t_{SDCK}) plus some minor adjustments for process, temperature, and voltage variations.

⁴ This specification relates to the required input setup time of DDR memories. The microprocessor's output setup should be larger than the input setup of the DDR memories. If it is not larger, then the input setup on the memory is in violation. $SD_D[31:24]$ is relative to $SD_DQS[3]$; $SD_D[23:16]$ is relative to $SD_DQS[2]$

⁵ The first data beat is valid before the first rising edge of DQS and after the DQS write preamble. The remaining data beats are valid for each subsequent DQS edge.

⁶ This specification relates to the required hold time of DDR memories. $SD_D[31:24]$ is relative to $SD_DQS[3]$; $SD_D[23:16]$ is relative to $SD_DQS[2]$

⁷ Data input skew is derived from each DQS clock edge. It begins with a DQS transition and ends when the last data line becomes valid. This input skew must include DDR memory output skew and system level board skew (due to routing or other factors).

⁸ Data input hold is derived from each DQS clock edge. It begins with a DQS transition and ends when the first data line becomes invalid.

Electrical Characteristics

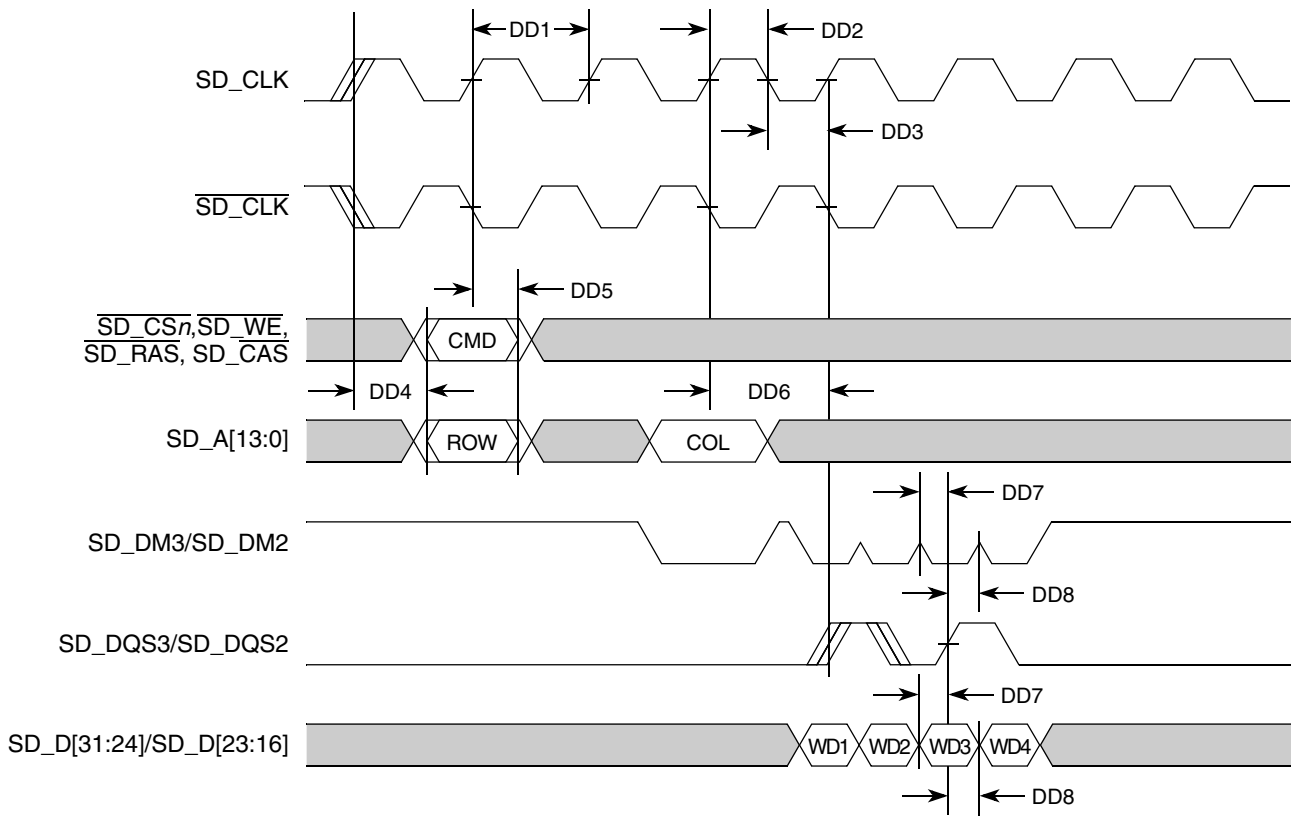

Figure 11. DDR Write Timing

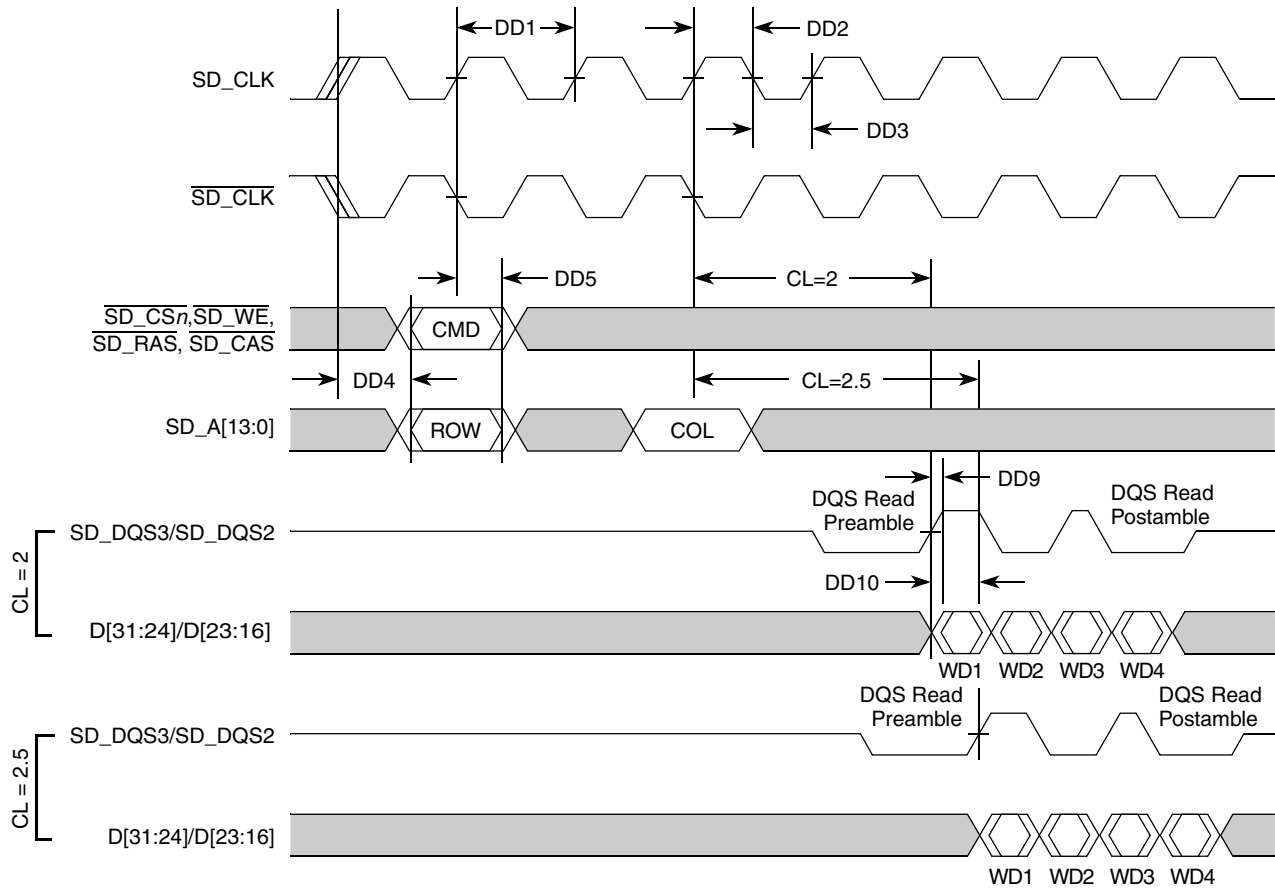

Figure 12. DDR Read Timing

5.9 PCI Bus Timing Specifications

The PCI bus on the device is PCI 2.2 compliant. The following timing numbers are mostly from the PCI 2.2 spec. Refer to the PCI 2.2 spec for a more detailed timing analysis.

Table 14. PCI Timing Specifications^{1,2}

Num	Characteristic	33 MHz ³		66 MHz ³		Unit
		Min	Max	Min	Max	
	Frequency of Operation	—	33.33	33.33	66.66	MHz
P1	Clock Period	30	—	15	30	ns
P2	Bused PCI signals — input setup	7.0	—	3.0	—	ns
P3	PCI_GNT[3:0]/PCI_REQ[3:0] — input setup	10.0	—	5.0	—	ns
P4	All PCI signals — input hold	0	—	0	—	ns
P5	Bused PCI signals — output valid	—	11.0	—	6.0	ns

Table 14. PCI Timing Specifications^{1,2} (continued)

Num	Characteristic	33 MHz ³		66 MHz ³		Unit
		Min	Max	Min	Max	
P6	PCI_REQ[3:0]/PCI_GNT[3:0] — output valid	—	12.0	—	6.0	ns
P7	All PCI signals — output hold	2.0	—	1.0	—	ns

¹ The PCI bus operates at the CLKIN frequency. All timings are relative to the input clock, CLKIN.

² All PCI signals are bused signals except for PCI_GNT[3:0] and PCI_REQ[3:0]. These signals are defined as point-to-point signals by the PCI Specification.

³ The 66-MHz parameters are only guaranteed when the 66-MHz PCI pad slew rates are selected. Likewise, the 33-MHz parameters are only guaranteed when the 33-MHz PCI pad slew rates are selected.

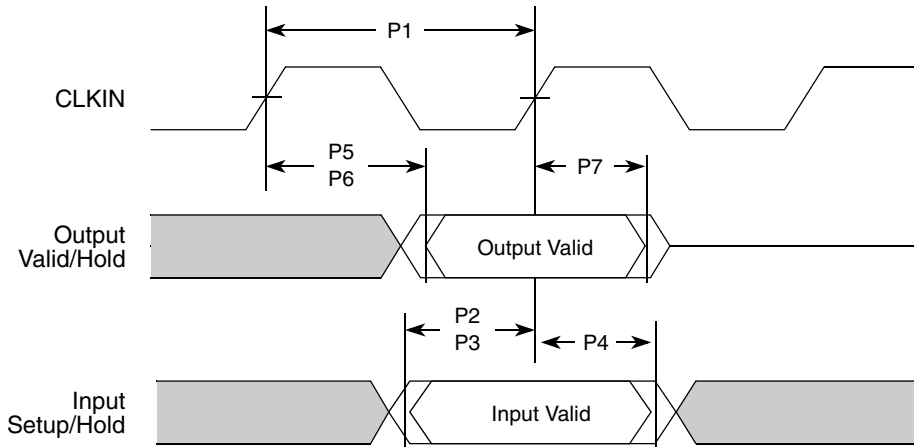

Figure 13. PCI Timing

5.9.1 Overshoot and Undershoot

Figure 14 shows the specification limits for overshoot and undershoot for PCI I/O. To guarantee long term reliability, the specification limits shown must be followed. Good transmission line design practices should be observed to guarantee the specification limits.

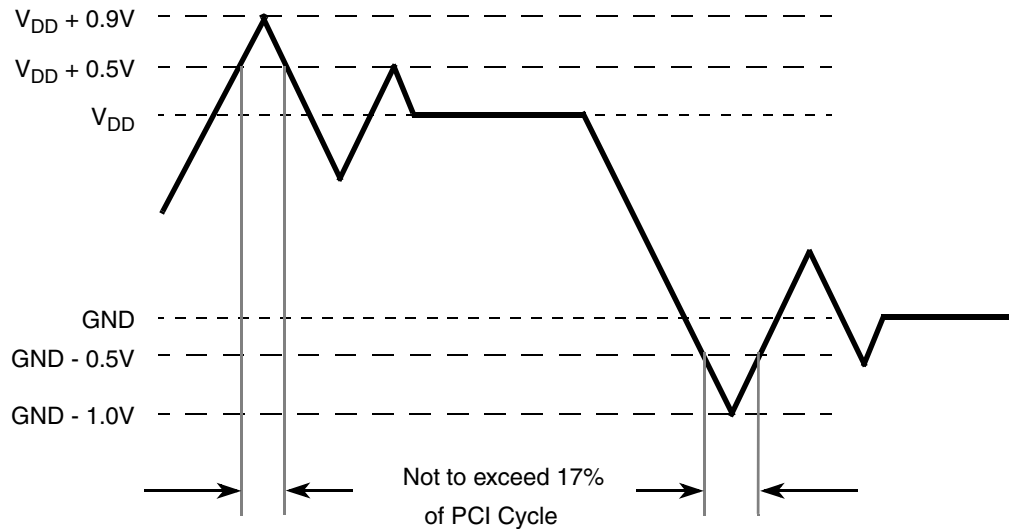

Figure 14. Overshoot and Undershoot Limits

5.10 ULPI Timing Specifications

The ULPI interface is fully compliant with the industry standard UTMI+ Low Pin Interface. Control and data timing requirements for the ULPI pins are given in Table 15. These timings apply to synchronous mode only. All timings are measured with respect to the clock as seen at the USB_CLKIN pin on the MCF5445x. The ULPI PHY is the source of the 60MHz clock.

NOTE

The USB controller requires a 60-MHz clock, even if using the on-chip FS/LS transceiver instead of the ULPI interface. In this case, the 60-MHz clock can be generated by the PLL or input on the USB_CLKIN pin.

Table 15. ULPI Interface Timing

Num	Characteristic	Min	Nominal	Max	Units
	USB_CLKIN operating frequency	—	60	—	MHz
	USB_CLKIN duty cycle	—	50	—	%
U1	USB_CLKIN clock period	—	16.67	—	ns
U2	Input Setup (control and data)	5.0	—	—	ns
U3	Input Hold (control and data)	1.0	—	—	ns
U4	Output Valid (control and data)	—	—	9.5	ns
U5	Output Hold (control and data)	1.0	—	—	

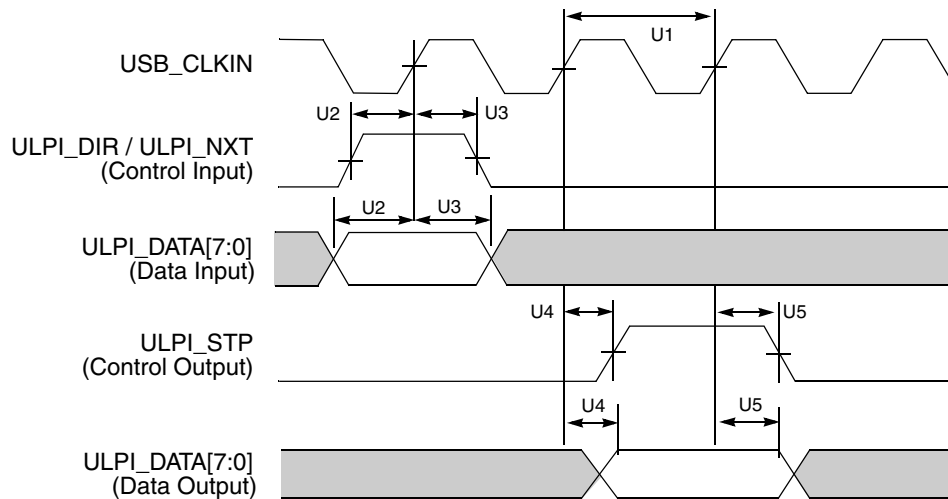

Figure 15. ULPI Timing Diagram

5.11 SSI Timing Specifications

This section provides the AC timings for the SSI in master (clocks driven) and slave modes (clocks input). All timings are given for non-inverted serial clock polarity (SSI_TCR[TSCKP] = 0, SSI_RCR[RSCKP] = 0) and a non-inverted frame sync (SSI_TCR[TFSI] = 0, SSI_RCR[RFSI] = 0). If the polarity of the clock and/or the frame sync have been inverted, all the timings remain valid by inverting the clock signal (SSI_BCLK) and/or the frame sync (SSI_FS) shown in the figures below.

Table 16. SSI Timing — Master Modes¹

Num	Description	Symbol	Min	Max	Units	Notes
S1	SSI_MCLK cycle time	t_{MCLK}	$2 \times t_{SYS}$	—	ns	²
S2	SSI_MCLK pulse width high / low		45%	55%	t_{MCLK}	
S3	SSI_BCLK cycle time	t_{BCLK}	$8 \times t_{SYS}$	—	ns	³
S4	SSI_BCLK pulse width		45%	55%	t_{BCLK}	
S5	SSI_BCLK to SSI_FS output valid		—	15	ns	
S6	SSI_BCLK to SSI_FS output invalid		0	—	ns	
S7	SSI_BCLK to SSI_TXD valid		—	15	ns	
S8	SSI_BCLK to SSI_TXD invalid / high impedance		-2	—	ns	
S9	SSI_RXD / SSI_FS input setup before SSI_BCLK		10	—	ns	
S10	SSI_RXD / SSI_FS input hold after SSI_BCLK		0	—	ns	

¹ All timings specified with a capacitive load of 25pF.

² SSI_MCLK can be generated from SSI_CLKIN or a divided version of the internal system clock (f_{SYS}).

³ SSI_BCLK can be derived from SSI_CLKIN or a divided version of the internal system clock (f_{SYS}).

Table 17. SSI Timing — Slave Modes¹

Num	Description	Symbol	Min	Max	Units	Notes
S11	SSI_BCLK cycle time	t_{BCLK}	$8 \times t_{SYS}$	—	ns	
S12	SSI_BCLK pulse width high / low		45%	55%	t_{BCLK}	
S13	SSI_FS input setup before SSI_BCLK		10	—	ns	
S14	SSI_FS input hold after SSI_BCLK		2	—	ns	
S15	SSI_BCLK to SSI_TXD / SSI_FS output valid		—	15	ns	
S16	SSI_BCLK to SSI_TXD / SSI_FS output invalid / high impedance		0	—	ns	
S17	SSI_RXD setup before SSI_BCLK		10	—	ns	
S18	SSI_RXD hold after SSI_BCLK		2	—	ns	

¹ All timings specified with a capacitive load of 25pF.

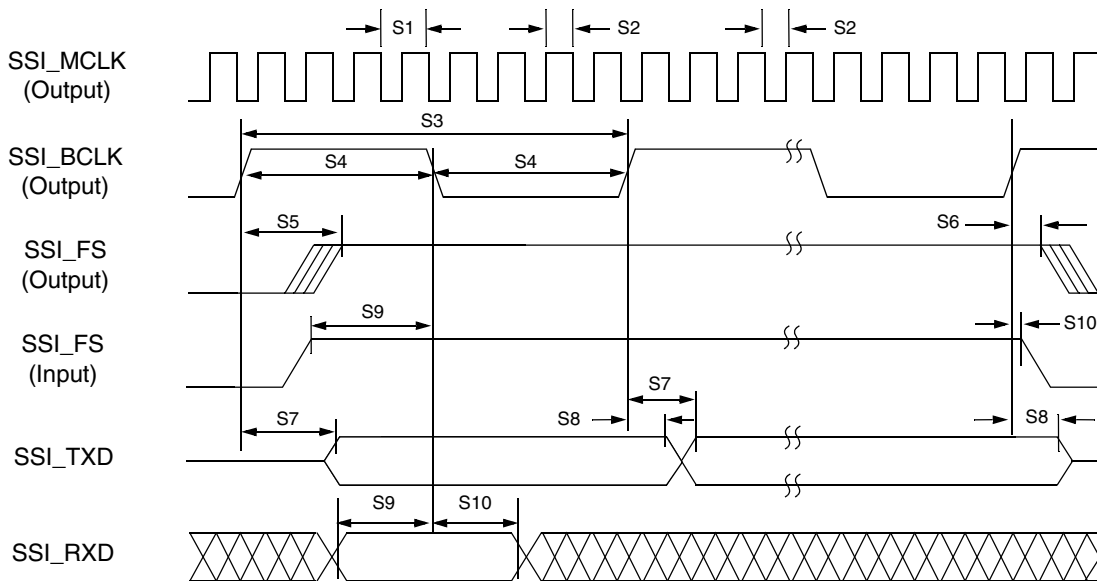

Figure 16. SSI Timing — Master Modes

Electrical Characteristics

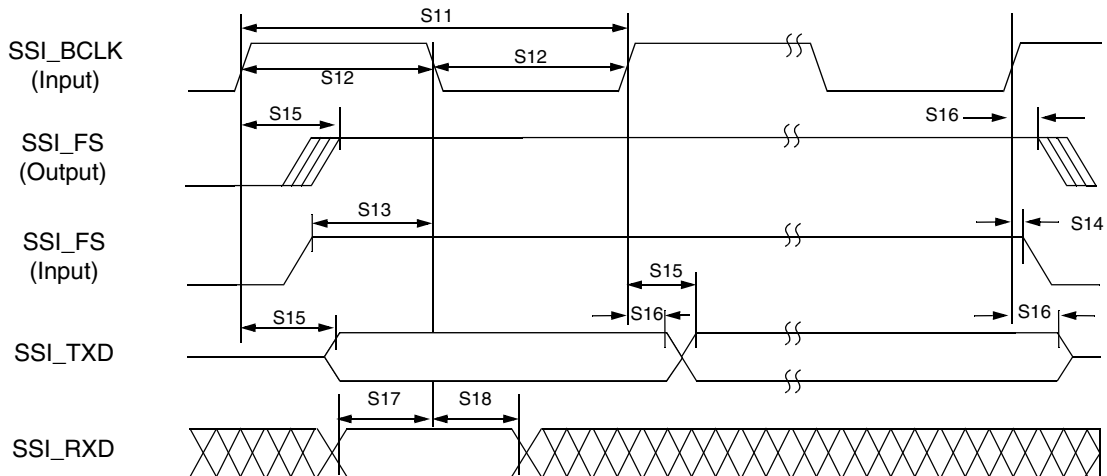

Figure 17. SSI Timing — Slave Modes

5.12 I²C Timing Specifications

Table 18 lists specifications for the I²C input timing parameters shown in Figure 18.

Table 18. I²C Input Timing Specifications between SCL and SDA

Num	Characteristic	Min	Max	Units
I1	Start condition hold time	2	—	t _{SYS}
I2	Clock low period	8	—	t _{SYS}
I3	I2C_SCL/I2C_SDA rise time (V _{IL} = 0.5 V to V _{IH} = 2.4 V)	—	1	ms
I4	Data hold time	0	—	ns
I5	I2C_SCL/I2C_SDA fall time (V _{IH} = 2.4 V to V _{IL} = 0.5 V)	—	1	ms
I6	Clock high time	4	—	t _{SYS}
I7	Data setup time	0	—	ns
I8	Start condition setup time (for repeated start condition only)	2	—	t _{SYS}
I9	Stop condition setup time	2	—	t _{SYS}

Table 19 lists specifications for the I²C output timing parameters shown in Figure 18.

Table 19. I²C Output Timing Specifications between SCL and SDA

Num	Characteristic	Min	Max	Units
I1 ¹	Start condition hold time	6	—	t _{SYS}
I2 ¹	Clock low period	10	—	t _{SYS}
I3 ²	I2C_SCL/I2C_SDA rise time (V _{IL} = 0.5 V to V _{IH} = 2.4 V)	—	—	μs
I4 ¹	Data hold time	7	—	t _{SYS}
I5 ³	I2C_SCL/I2C_SDA fall time (V _{IH} = 2.4 V to V _{IL} = 0.5 V)	—	3	ns

Table 19. I²C Output Timing Specifications between SCL and SDA (continued)

Num	Characteristic	Min	Max	Units
I6 ¹	Clock high time	10	—	t _{SYS}
I7 ¹	Data setup time	2	—	t _{SYS}
I8 ¹	Start condition setup time (for repeated start condition only)	20	—	t _{SYS}
I9 ¹	Stop condition setup time	10	—	t _{SYS}

¹ Output numbers depend on the value programmed into the IFDR; an IFDR programmed with the maximum frequency (IFDR = 0x20) results in minimum output timings as shown in Table 19. The I²C interface is designed to scale the actual data transition time to move it to the middle of the SCL low period. The actual position is affected by the prescale and division values programmed into the IFDR. However, the numbers given in Table 19 are minimum values.

² Because I2C_SCL and I2C_SDA are open-collector-type outputs, which the processor can only actively drive low, the time I2C_SCL or I2C_SDA take to reach a high level depends on external signal capacitance and pull-up resistor values.

³ Specified at a nominal 50-pF load.

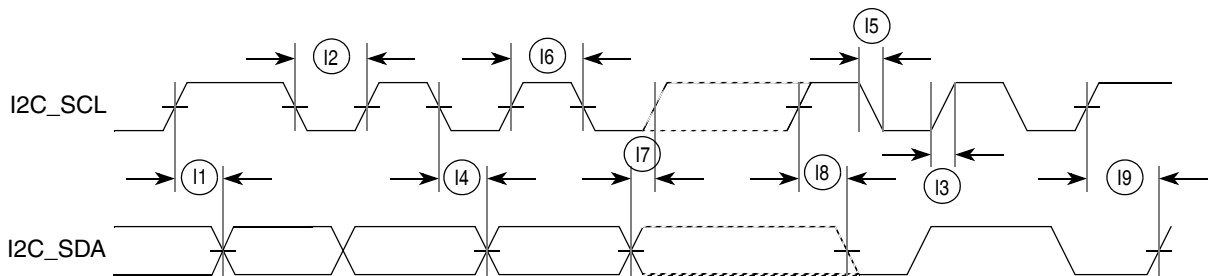
**Figure 18. I²C Input/Output Timings**

5.13 Fast Ethernet Timing Specifications

The following timing specs are defined at the chip I/O pin and must be translated appropriately to arrive at timing specs/constraints for the physical interface.

5.13.1 Receive Signal Timing Specifications

The following timing specs meet the requirements for MII and 7-Wire style interfaces for a range of transceiver devices.

Table 20. Receive Signal Timing

Num	Characteristic	MII Mode		RMII Mode		Unit
		Min	Max	Min	Max	
—	RXCLK frequency	—	25	—	50	MHz
E1	RXD[n:0], RXDV, RXER to RXCLK setup ¹	5	—	4	—	ns
E2	RXCLK to RXD[n:0], RXDV, RXER hold ¹	5	—	2	—	ns
E3	RXCLK pulse width high	35%	65%	35%	65%	RXCLK period
E4	RXCLK pulse width low	35%	65%	35%	65%	RXCLK period

¹ In MII mode, n = 3; In RMII mode, n = 1

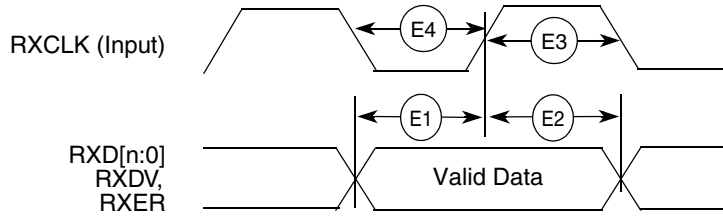

Figure 19. MII Receive Signal Timing Diagram

5.13.2 Transmit Signal Timing Specifications

Table 21. Transmit Signal Timing

Num	Characteristic	MII Mode		RMII Mode		Unit
		Min	Max	Min	Max	
—	TXCLK frequency	—	25	—	50	MHz
E5	TXCLK to TXD[n:0], TXEN, TXER invalid ¹	5	—	5	—	ns
E6	TXCLK to TXD[n:0], TXEN, TXER valid ¹	—	25	—	14	ns
E7	TXCLK pulse width high	35%	65%	35%	65%	t_{TXCLK}
E8	TXCLK pulse width low	35%	65%	35%	65%	t_{TXCLK}

¹ In MII mode, n = 3; In RMII mode, n = 1

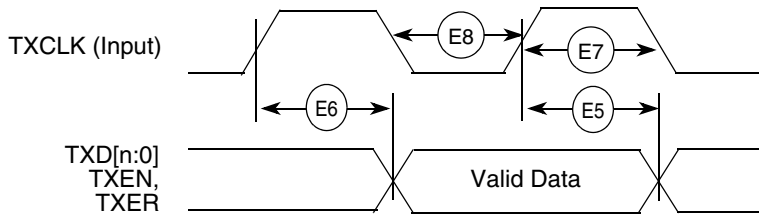

Figure 20. MII Transmit Signal Timing Diagram

5.13.3 Asynchronous Input Signal Timing Specifications

Table 22. MII Transmit Signal Timing

Num	Characteristic	Min	Max	Unit
E9	CRS, COL minimum pulse width	1.5	—	TXCLK period

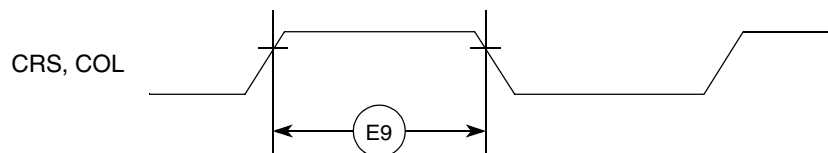

Figure 21. MII Async Inputs Timing Diagram

5.13.4 MII Serial Management Timing Specifications

Table 23. MII Serial Management Channel Signal Timing

Num	Characteristic	Symbol	Min	Max	Unit
E10	MDC cycle time	t_{MDC}	400	—	ns
E11	MDC pulse width		40	60	% t_{MDC}
E12	MDC to MDIO output valid		—	375	ns
E13	MDC to MDIO output invalid		25	—	ns
E14	MDIO input to MDC setup		10	—	ns
E15	MDIO input to MDC hold		0	—	ns

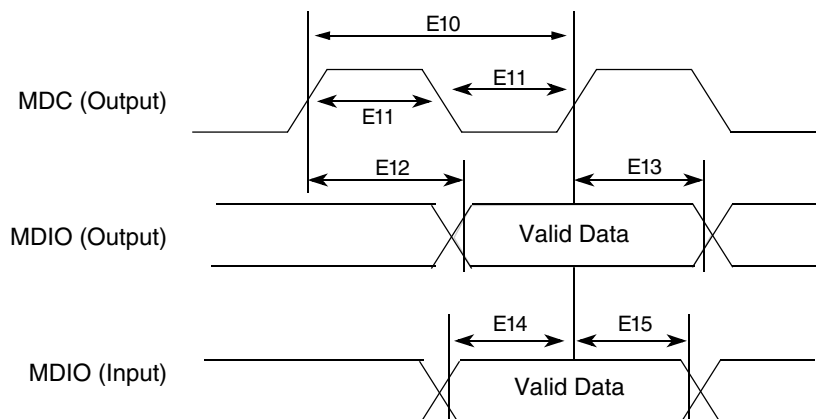

Figure 22. MII Serial Management Channel Timing Diagram

5.14 32-Bit Timer Module Timing Specifications

Table 24 lists timer module AC timings.

Table 24. Timer Module AC Timing Specifications

Name	Characteristic	Min	Max	Unit
T1	$DTnIN$ cycle time ($n = 0:3$)	3	—	$t_{sys}/2$
T2	$DTnIN$ pulse width ($n = 0:3$)	1	—	$t_{sys}/2$

5.15 ATA Interface Timing Specifications

The ATA controller is compatible with the ATA/ATAPI-6 industry standard. Refer to the *ATA/ATAPI-6 Specification* and the ATA controller chapter of the *MCF54455 Reference Manual* for timing diagrams of the various modes of operation.

The timings of the various ATA data transfer modes are determined by a set of timing equations described in the ATA section of the *MCF54455 Reference Manual*. These timing equations must be fulfilled for the ATA host to meet timing. [Table 25](#) provides implementation specific timing parameters necessary to complete the timing equations.

Table 25. ATA Interface Timing Specifications^{1,2}

Name	Characteristic	Symbol	Min	Max	Unit	Notes
A1	Setup time — ATA_IORDY to SYSCLK falling	t_{SUI}	4.0	—	ns	
A2	Hold time — ATA_IORDY from SYSCLK falling	t_{HI}	3.0	—	ns	
A3	Setup time — ATA_DATA[15:0] to SYSCLK rising	t_{SU}	4.0	—	ns	
A4	Propagation delay — SYSCLK rising to all outputs	t_{CO}	—	7.0	ns	3
A5	Output skew	t_{SKEW1}	—	1.5	ns	3
A6	Setup time — ATA_DATA[15:0] valid to ATA_IORDY	t_{I_DS}	2.0	—	ns	4
A7	Hold time — ATA_IORDY to ATA_DATA[15:0] invalid	t_{I_DH}	3.5	—	ns	4

¹ These parameters are guaranteed by design and not testable.

² All timings specified with a capacitive load of 40pF.

³ Applies to $\overline{ATA_CS}[1:0]$, $\overline{ATA_DA}[2:0]$, $\overline{ATA_DIOR}$, $\overline{ATA_DIOW}$, $\overline{ATA_DMACK}$, $\overline{ATA_DATA}[15:0]$

⁴ Applies to Ultra DMA data-in burst only

5.16 DSPI Timing Specifications

The DMA Serial Peripheral Interface (DSPI) provides a synchronous serial bus with master and slave operations. Many of the transfer attributes are programmable. [Table 26](#) provides DSPI timing characteristics for classic SPI timing modes. Refer to the DSPI chapter of the *MCF54455 Reference Manual* for information on the modified transfer formats used for communicating with slower peripheral devices.

Table 26. DSPI Module AC Timing Specifications¹

Name	Characteristic	Symbol	Min	Max	Unit	Notes
DS1	DSPI_SCK Cycle Time	t_{SCK}	$4 \times t_{SYS}$	—	ns	2
DS2	DSPI_SCK Duty Cycle	—	$(t_{SCK} \div 2) - 2.0$	$(t_{SCK} \div 2) + 2.0$	ns	3
Master Mode						
DS3	DSPI_PCS n to DSPI_SCK delay	t_{CSC}	$(2 \times t_{SYS}) - 1.5$	—	ns	4
DS4	DSPI_SCK to DSPI_PCS n delay	t_{ASC}	$(2 \times t_{SYS}) - 3.0$	—	ns	5
DS5	DSPI_SCK to DSPI_SOUT valid	—	—	5	ns	
DS6	DSPI_SCK to DSPI_SOUT invalid	—	-5	—	ns	
DS7	DSPI_SIN to DSPI_SCK input setup	—	9	—	ns	
DS8	DSPI_SCK to DSPI_SIN input hold	—	0	—	ns	
Slave Mode						
DS9	DSPI_SCK to DSPI_SOUT valid	—	—	10	ns	

Table 26. DSPI Module AC Timing Specifications¹ (continued)

Name	Characteristic	Symbol	Min	Max	Unit	Notes
DS10	DSPI_SCK to DSPI_SOUT invalid	—	0	—	ns	
DS11	DSPI_SIN to DSPI_SCK input setup	—	2	—	ns	
DS12	DSPI_SCK to DSPI_SIN input hold	—	7	—	ns	
DS13	$\overline{\text{DSPI_SS}}$ active to DSPI_SOUT driven	—	—	10	ns	
DS14	$\overline{\text{DSPI_SS}}$ inactive to DSPI_SOUT not driven	—	—	10	ns	

¹ Timings shown are for DMCR[MTEF] = 0 (classic SPI) and DCTAR η [CPHA] = 0. Data is sampled on the DSPI_SIN pin on the odd-numbered DSPI_SCK edges and driven on the DSPI_SOUT pin on even-numbered DSPI edges.

² When in master mode, the baud rate is programmable in DCTAR η [DBR], DCTAR η [PBR], and DCTAR η [BR].

³ This specification assumes a 50/50 duty cycle setting. The duty cycle is programmable in DCTAR η [DBR], DCTAR η [CPHA], and DCTAR η [PBR].

⁴ The DSPI_PCS n to DSPI_SCK delay is programmable in DCTAR η [PCSSCK] and DCTAR η [CSSCK].

⁵ The DSPI_SCK to DSPI_PCS n delay is programmable in DCTAR η [PASC] and DCTAR η [ASC].

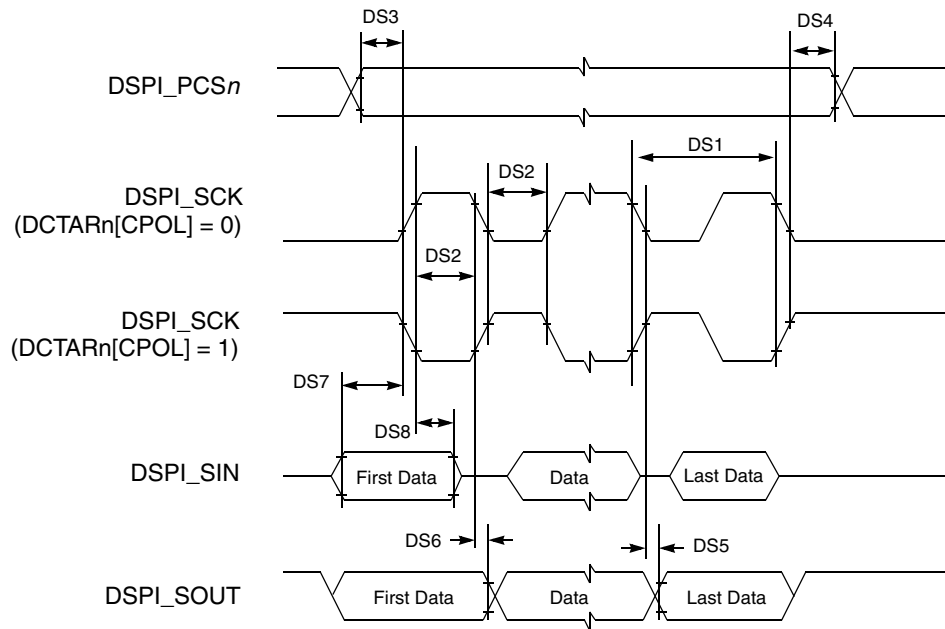

Figure 23. DSPI Classic SPI Timing — Master Mode

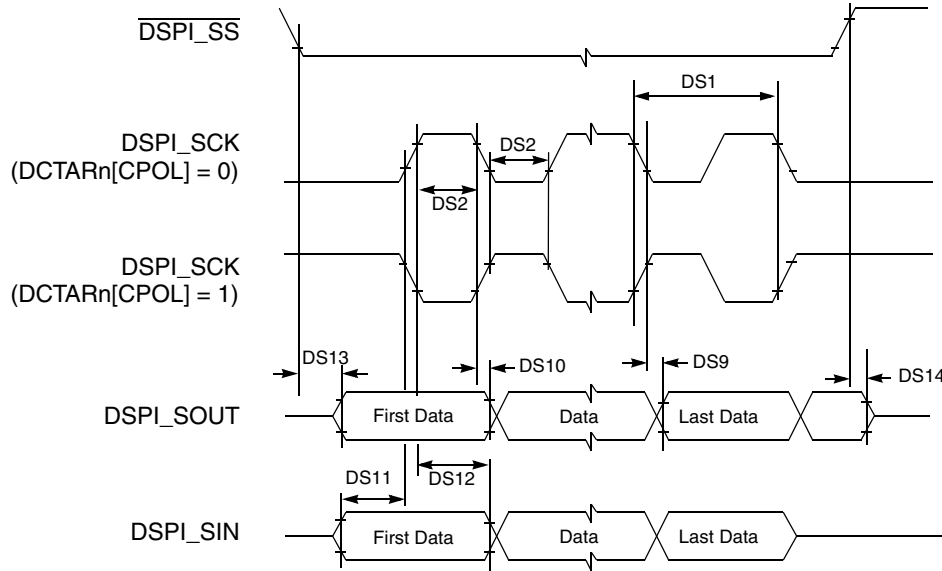

Figure 24. DSPI Classic SPI Timing — Slave Mode

5.17 SBF Timing Specifications

The Serial Boot Facility (SBF) provides a means to read configuration information and system boot code from a broad array of SPI-compatible EEPROMs, flashes, FRAMs, nVSRAMs, etc. Table 27 provides the AC timing specifications for the SBF.

Table 27. SBF AC Timing Specifications

Name	Characteristic	Symbol	Min	Max	Unit	Notes
SB1	SBF_CK Cycle Time	t_{SBFCK}	40	—	ns	1
SB2	SBF_CK High/Low Time	—	30%	—	t_{SBFCK}	
SB3	$\overline{SBF_CS}$ to SBF_CK delay	—	$t_{SBFCK} - 2.0$	—	ns	
SB4	SBF_CK to $\overline{SBF_CS}$ delay	—	$t_{SBFCK} - 2.0$	—	ns	
SB5	SBF_CK to SBF_DO valid	—	-5	—	ns	
SB6	SBF_CK to SBF_DO invalid	—	5	—	ns	
SB7	SBF_DI to SBF_SCK input setup	—	10	—	ns	
SB8	SBF_CK to SBF_DI input hold	—	0	—	ns	

¹ At reset, the SBF_CK cycle time is $t_{REF} \times 67$. The first byte of data read from the serial memory contains a divider value that is used to set the SBF_CK cycle time for the duration of the serial boot process.

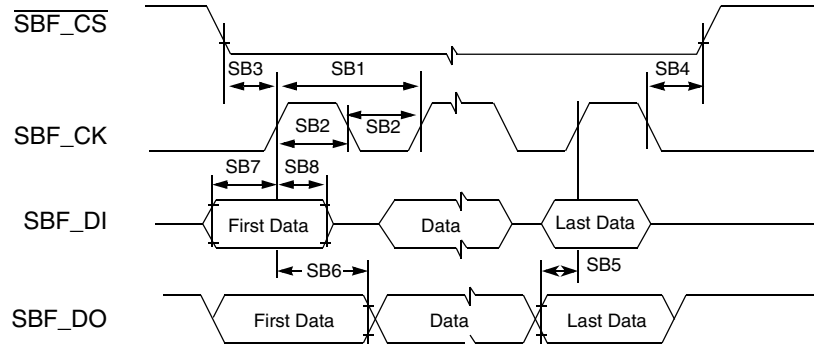

Figure 25. SBF Timing

5.18 General Purpose I/O Timing Specifications

Table 28. GPIO Timing¹

Num	Characteristic	Min	Max	Unit
G1	FB_CLK High to GPIO Output Valid	—	9	ns
G2	FB_CLK High to GPIO Output Invalid	1.5	—	ns
G3	GPIO Input Valid to FB_CLK High	9	—	ns
G4	FB_CLK High to GPIO Input Invalid	1.5	—	ns

¹ These general purpose specifications apply to the following signals: \overline{IRQn} , all UART signals, all timer signals, \overline{DACKn} and \overline{DREQn} , and all signals configured as GPIO.

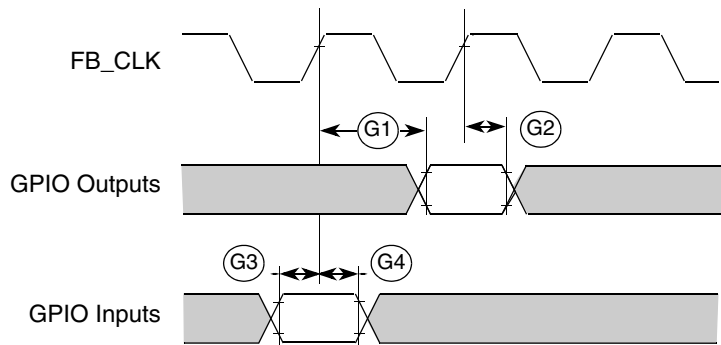

Figure 26. GPIO Timing

5.19 JTAG and Boundary Scan Timing

Table 29. JTAG and Boundary Scan Timing

Num	Characteristics ¹	Min	Max	Unit
J1	TCLK Frequency of Operation	DC	20	MHz
J2	TCLK Cycle Period	50	—	ns
J3	TCLK Clock Pulse Width	20	30	ns
J4	TCLK Rise and Fall Times	—	3	ns
J5	Boundary Scan Input Data Setup Time to TCLK Rise	5	—	ns
J6	Boundary Scan Input Data Hold Time after TCLK Rise	20	—	ns
J7	TCLK Low to Boundary Scan Output Data Valid	—	33	ns
J8	TCLK Low to Boundary Scan Output High Z	—	33	ns
J9	TMS, TDI Input Data Setup Time to TCLK Rise	4	—	ns
J10	TMS, TDI Input Data Hold Time after TCLK Rise	10	—	ns
J11	TCLK Low to TDO Data Valid	—	11	ns
J12	TCLK Low to TDO High Z	—	11	ns
J13	$\overline{\text{TRST}}$ Assert Time	50	—	ns
J14	$\overline{\text{TRST}}$ Setup Time (Negation) to TCLK High	10	—	ns

¹ JTAG_EN is expected to be a static signal. Hence, specific timing is not associated with it.

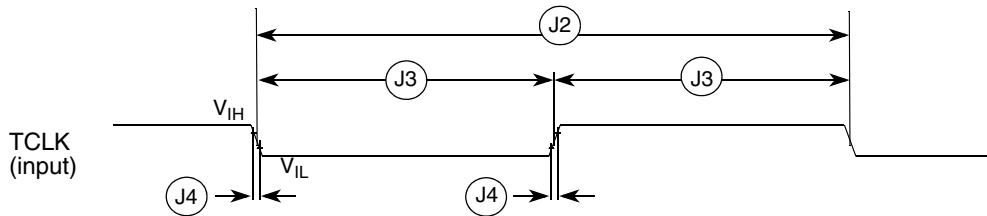

Figure 27. Test Clock Input Timing

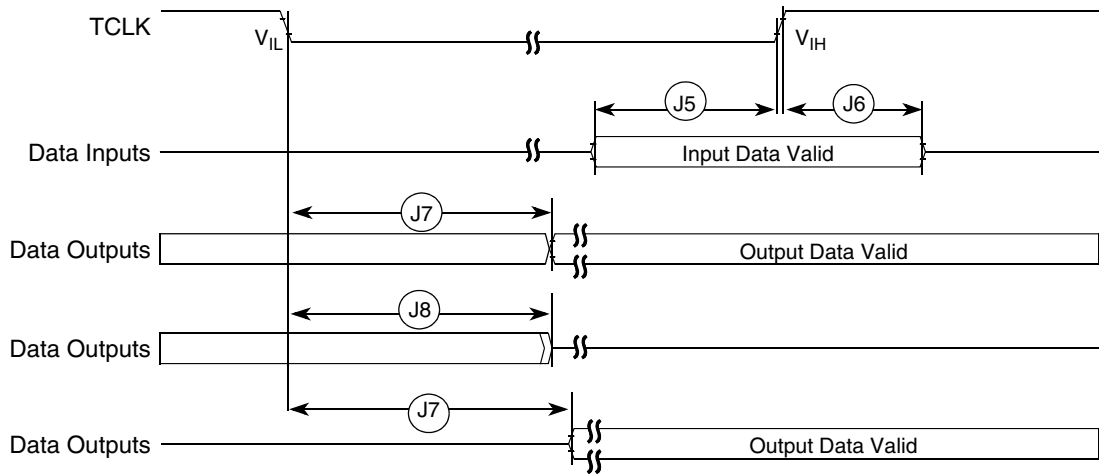

Figure 28. Boundary Scan (JTAG) Timing

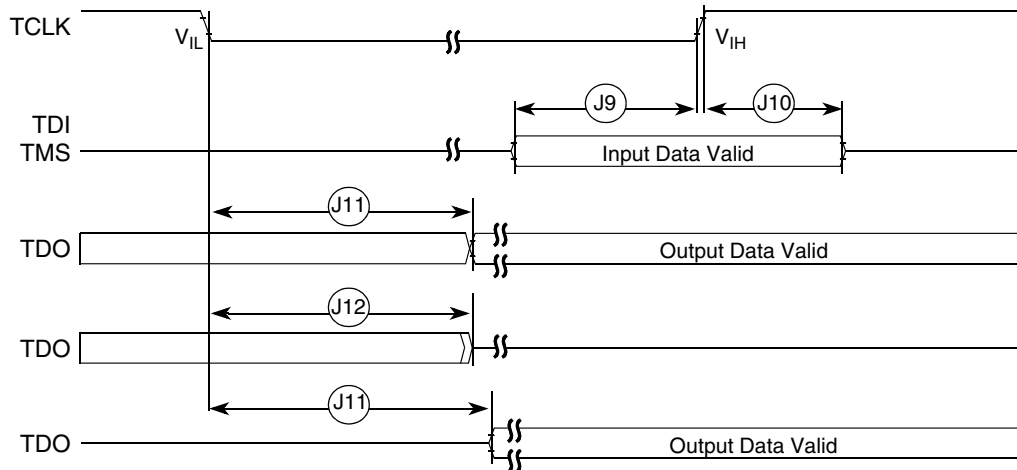

Figure 29. Test Access Port Timing

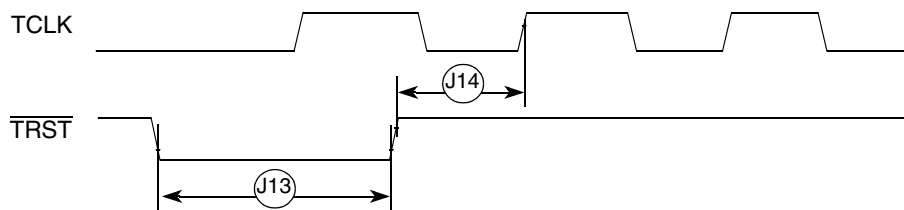

Figure 30. $\overline{\text{TRST}}$ Timing

5.20 Debug AC Timing Specifications

Table 30 lists specifications for the debug AC timing parameters shown in Figure 31 and Table 32.

Table 30. Debug AC Timing Specification

Num	Characteristic	Min	Max	Units
D0	PSTCLK cycle time	1	1	t_{sys}
D1	PSTCLK rising to PSTDDATA valid	—	3.0	ns
D2	PSTCLK rising to PSTDDATA invalid	1.5	—	ns
D3	DSI-to-DSCLK setup	1	—	PSTCLK
D4 ¹	DSCLK-to-DSO hold	4	—	PSTCLK
D5	DSCLK cycle time	5	—	PSTCLK
D6	BKPT assertion time	1	—	PSTCLK

¹ DSCLK and DSI are synchronized internally. D4 is measured from the synchronized DSCLK input relative to the rising edge of PSTCLK.

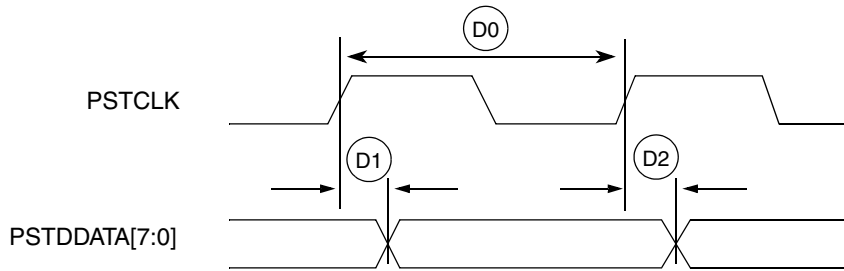

Figure 31. Real-Time Trace AC Timing

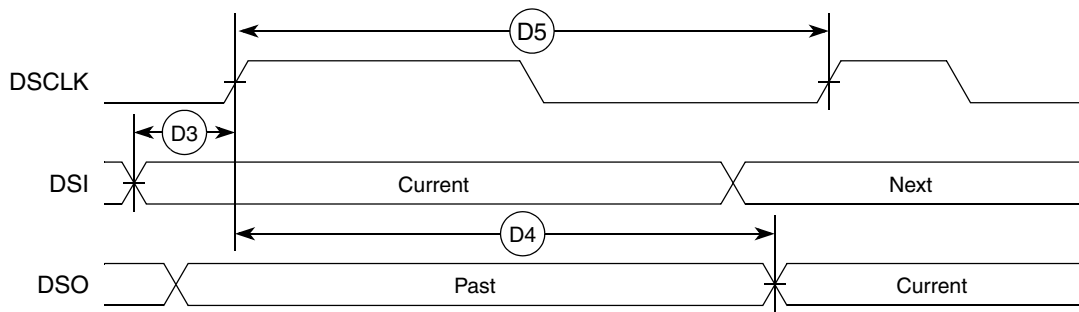

Figure 32. BDM Serial Port AC Timing

6 Power Consumption

All power consumption data is lab data measured on an M54455EVB running the Freescale Linux BSP.

Table 31. MCF4455 Application Power Consumption¹

Core Freq.		Idle	MP3 Playback	TFTP Download	USB HS File Copy	Units
266 MHz	IV _{DD}	215.6	288.8	274.4	263.7	mA
	EV _{DD}	27.6	33.6	32.6	32.4	
	SDV _{DD}	142.9	158.2	161.1	158.0	
	Total Power	672	829	809	787	mW
200 MHz	IV _{DD}	163.8	228.0	213.8	207.9	mA
	EV _{DD}	29.9	34.7	34.3	33.8	
	SDV _{DD}	142.2	158.5	160.0	153.4	
	Total Power	601	742	722	699	mW

¹ All voltage rails at nominal values: IV_{DD} = 1.5 V, EV_{DD} = 3.3 V, and SDV_{DD} = 1.8 V.

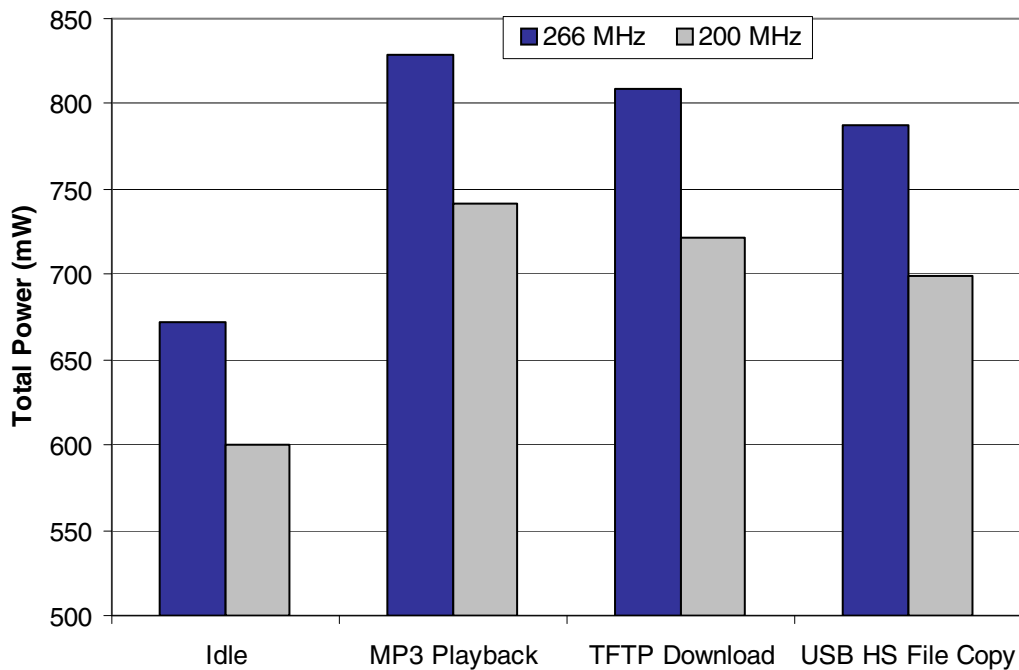

Figure 33. Power Consumption in Various Applications

Power Consumption

All current consumption data is lab data measured on a single device using an evaluation board. Table 32 shows the typical power consumption in low-power modes. These current measurements are taken after executing a STOP instruction.

Table 32. Current Consumption in Low-Power Modes^{1,2}

Mode	Voltage Supply	System Frequency				
		166 (Typ) ³	200 (Typ) ³	233 (Typ) ³	266 (Typ) ³	266 (Peak) ⁴
RUN	$I_{V_{DD}}$ (mA)	93.4	110.9	128.2	145.4	202.1
	Power (mW)	140.1	166.3	192.4	218.1	303.2
WAIT/DOZE	$I_{V_{DD}}$ (mA)	28.0	32.7	37.5	41.1	100.2
	Power (mW)	42.0	49.1	56.2	61.7	150.3
STOP 0	$I_{V_{DD}}$ (mA)	17.1	19.8	22.5	25.2	25.2
	Power (mW)	25.7	29.7	33.7	37.8	37.8
STOP 1	$I_{V_{DD}}$ (mA)	17.9	19.8	22.4	25.1	25.1
	Power (mW)	26.8	29.6	33.6	37.6	37.6
STOP 2	$I_{V_{DD}}$ (mA)	5.7	5.7	5.7	5.7	5.7
	Power (mW)	8.6	8.6	8.6	8.6	8.6
STOP 3	$I_{V_{DD}}$ (mA)	1.8	1.8	1.8	1.8	1.8
	Power (mW)	2.6	2.6	2.6	2.6	2.6

¹ All values are measured on an M54455EVB with 1.5V $I_{V_{DD}}$ power supply. Tests performed at room temperature.

² Refer to the Power Management chapter in the *MCF54455 Reference Manual* for more information on low-power modes.

³ All peripheral clocks are off except UART0, INTC0, IACK, edge port, reset controller, CCM, PLL, and FlexBus prior to entering low-power mode.

⁴ All peripheral clocks on prior to entering low-power mode.

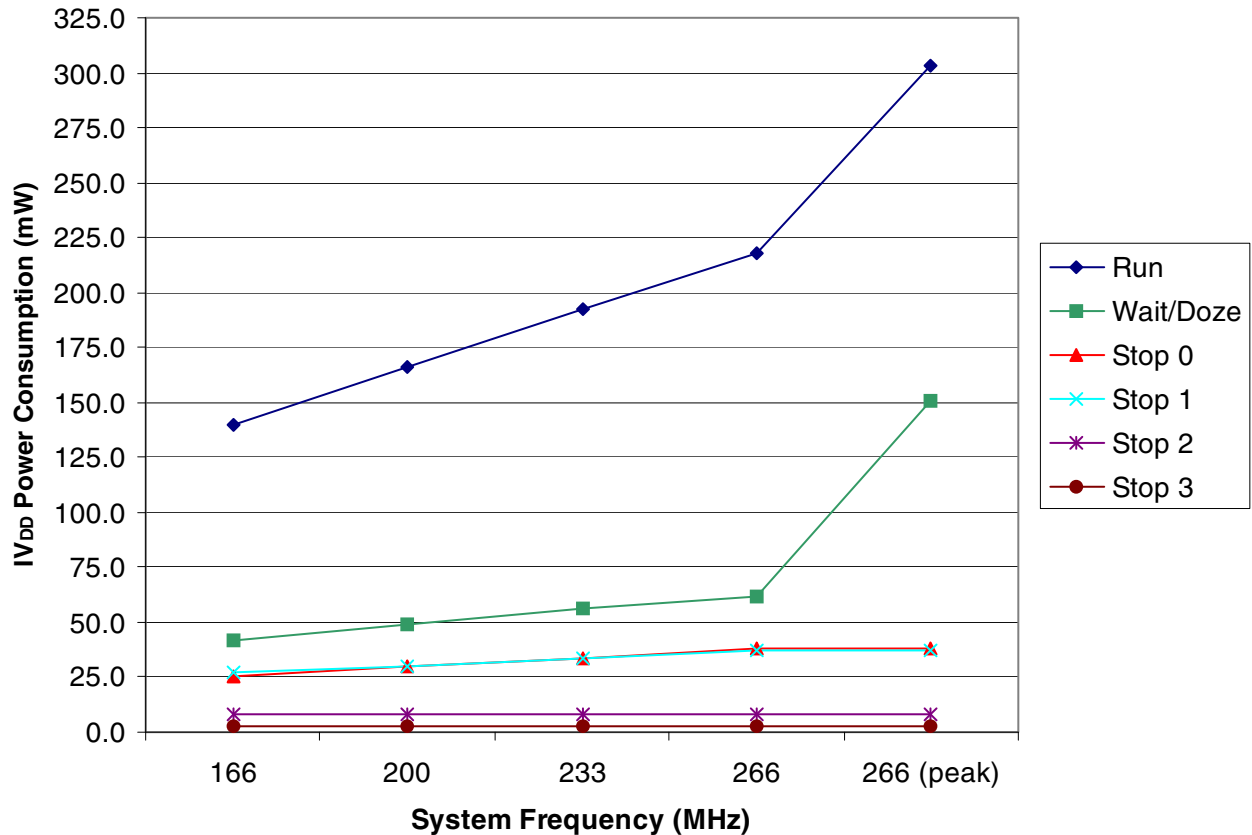
Figure 34. IV_{DD} Power Consumption in Low-Power Modes

7 Package Information

The latest package outline drawings are available on the product summary pages on <http://www.freescale.com/coldfire>. Table 33 lists the case outline numbers per device. Use these numbers in the web page's keyword search engine to find the latest package outline drawings.

Table 33. Package Information

Device	Package Type	Case Outline Numbers
MCF54450	256 MAPBGA	98ARH98219A
MCF54451		
MCF54452	360 TEPBGA	98ARE10605D
MCF54453		
MCF54454		
MCF54455		

8 Product Documentation

Documentation is available from a local Freescale distributor, a Freescale sales office, the Freescale Literature Distribution Center, or through the Freescale world-wide web address at <http://www.freescale.com/coldfire>.

9 Revision History

Table 34 summarizes revisions to this document.

Table 34. Revision History

Rev. No.	Date	Summary of Changes
0	Sept 17, 2007	Initial public release.
1	Feb 15, 2008	Corrected VSS pin locations in MCF5445x signal information and muxing table for the 360 TEPBGA package: changed "...M9, M16, M17..." to "...M9–M14, M16..." Updated FlexBus read and write timing diagrams and added two notes before them. Change FB_A[23:0] to FB_A[31:0] in FlexBus read and write timing diagrams. Added power consumption section.
2	May 1, 2008	In Family Configurations table, added PCI as feature on 256-pin devices. On these devices the PCI_AD bus is limited to 24-bits. In Absolute Maximum Ratings table, changed RTCV _{DD} specification from "-0.3 to +4.0" to "-0.5 to +2.0". In DC Electrical Specifications table: <ul style="list-style-type: none"> • Changed RTCV_{DD} specification from 3.0–3.6 to 1.35–1.65. • Changed High Impedance (Off-State) Leakage Current (I_{OZ}) specification from ±1 to ±10μA, and added footnote to this spec: "Worst-case tristate leakage current with only one I/O pin high. Since all I/Os share power when high, the leakage current is distributed among them. With all I/Os high, this spec reduces to ±2 μA min/max."

How to Reach Us:

Home Page:

www.freescale.com

Web Support:

<http://www.freescale.com/support>

USA/Europe or Locations Not Listed:

Freescale Semiconductor, Inc.
Technical Information Center, EL516
2100 East Elliot Road
Tempe, Arizona 85284
+1-800-521-6274 or +1-480-768-2130
www.freescale.com/support

Europe, Middle East, and Africa:

Freescale Halbleiter Deutschland GmbH
Technical Information Center
Schatzbogen 7
81829 Muenchen, Germany
+44 1296 380 456 (English)
+46 8 52200080 (English)
+49 89 92103 559 (German)
+33 1 69 35 48 48 (French)
www.freescale.com/support

Japan:

Freescale Semiconductor Japan Ltd.
Headquarters
ARCO Tower 15F
1-8-1, Shimo-Meguro, Meguro-ku,
Tokyo 153-0064
Japan
0120 191014 or +81 3 5437 9125
support.japan@freescale.com

Asia/Pacific:

Freescale Semiconductor Hong Kong Ltd.
Technical Information Center
2 Dai King Street
Tai Po Industrial Estate
Tai Po, N.T., Hong Kong
+800 2666 8080
support.asia@freescale.com

For Literature Requests Only:

Freescale Semiconductor Literature Distribution Center
P.O. Box 5405
Denver, Colorado 80217
1-800-441-2447 or 303-675-2140
Fax: 303-675-2150
LDCForFreescaleSemiconductor@hibbertgroup.com

Document Number: MCF54455

Rev. 2

05/2008

Information in this document is provided solely to enable system and software implementers to use Freescale Semiconductor products. There are no express or implied copyright licenses granted hereunder to design or fabricate any integrated circuits or integrated circuits based on the information in this document.

Freescale Semiconductor reserves the right to make changes without further notice to any products herein. Freescale Semiconductor makes no warranty, representation or guarantee regarding the suitability of its products for any particular purpose, nor does Freescale Semiconductor assume any liability arising out of the application or use of any product or circuit, and specifically disclaims any and all liability, including without limitation consequential or incidental damages. "Typical" parameters that may be provided in Freescale Semiconductor data sheets and/or specifications can and do vary in different applications and actual performance may vary over time. All operating parameters, including "Typicals", must be validated for each customer application by customer's technical experts. Freescale Semiconductor does not convey any license under its patent rights nor the rights of others. Freescale Semiconductor products are not designed, intended, or authorized for use as components in systems intended for surgical implant into the body, or other applications intended to support or sustain life, or for any other application in which the failure of the Freescale Semiconductor product could create a situation where personal injury or death may occur. Should Buyer purchase or use Freescale Semiconductor products for any such unintended or unauthorized application, Buyer shall indemnify and hold Freescale Semiconductor and its officers, employees, subsidiaries, affiliates, and distributors harmless against all claims, costs, damages, and expenses, and reasonable attorney fees arising out of, directly or indirectly, any claim of personal injury or death associated with such unintended or unauthorized use, even if such claim alleges that Freescale Semiconductor was negligent regarding the design or manufacture of the part.

RoHS-compliant and/or Pb-free versions of Freescale products have the functionality and electrical characteristics as their non-RoHS-compliant and/or non-Pb-free counterparts. For further information, see <http://www.freescale.com> or contact your Freescale sales representative.

For information on Freescale's Environmental Products program, go to <http://www.freescale.com/epp>.

Freescale™ and the Freescale logo are trademarks of Freescale Semiconductor, Inc. All other product or service names are the property of their respective owners.
© Freescale Semiconductor, Inc. 2008. All rights reserved.

