

3-Mode Surround and Vocal Cancellation

Description

The CXA1842S is a bipolar IC which combines 3-mode surround, bass boosting and vocal cancellation function into a single chip.

Features

- 3-mode surround (surround A, surround B, simulated stereo)
- Vocal cancellation function
- Bass boosting function

Applications

CD Radio-cassette tape recorders, equipment with Karaoke functions

Structure

Bipolar silicon monolithic IC

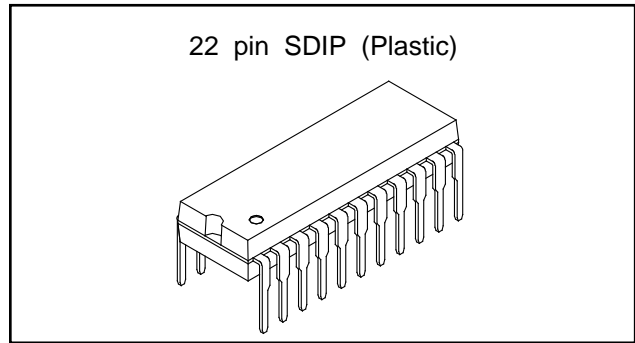

Absolute Maximum Ratings (Ta=25°C)

• Supply voltage	VCC	14	V
• Operating temperature	Topr	-20 to +75	°C
• Storage temperature	Tstg	-65 to +150	°C
• Allowable power dissipation	Pd	880	mW

Recommended Operating Conditions

Supply voltage	VCC	5 to 12	V
----------------	-----	---------	---

Block Diagram and Pin Configuration

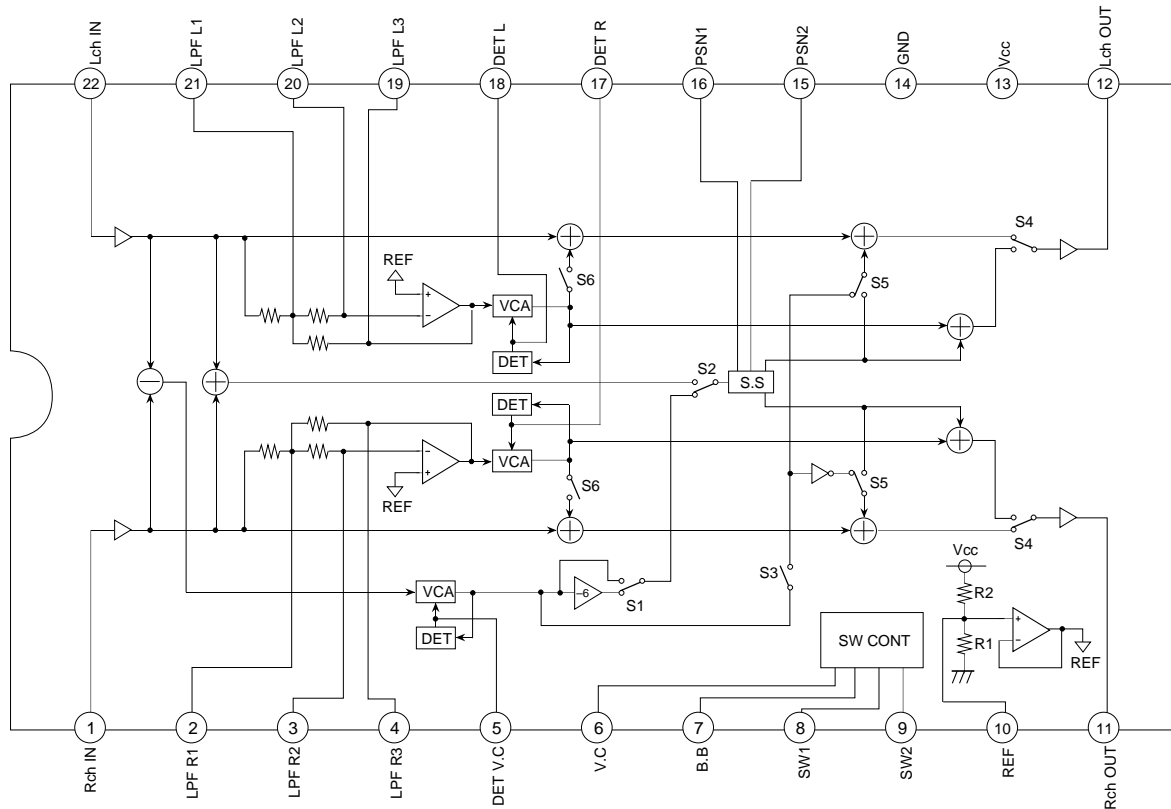

Sony reserves the right to change products and specifications without prior notice. This information does not convey any license by any implication or otherwise under any patents or other right. Application circuits shown, if any, are typical examples illustrating the operation of the devices. Sony cannot assume responsibility for any problems arising out of the use of these circuits.

Pin Description

(Vcc=10V, Ta=25°C)

Pin No.	Symbol	Pin Voltage	Equivalent Circuit	Description
1 22	Rch IN Lch IN	5.0V		Channel L Channel R input pin
2 21 3 20 4 19	LPF R1 LPF L1 LPF R2 LPF L2 LPF R3 LPF L3	5.0V		Time constants for L.P.F.
5 17 18	DET V.C DET R DET L	0.5V		Level detector pin. To be connected with a capacitor

Pin No.	Symbol	Pin Voltage	Equivalent Circuit	Description
6	V.C	—		SW is turned ON when this pin is connected to GND
7	B.B			
8	SW 1			
9	SW 2			
10	REF	5.0V		Reference voltage (1/2 Vcc)
11	Rch OUT	5.0V		Channel R output pin
12	Lch OUT			Channel L output pin
13	Vcc	10V		Power supply
14	GND	0		GND pin
15	PSN 2	5.0V		The pin to be connected with a capacitor for time constants of phase shift
16	PSN 1			

Electrical Characteristics

(VCC=10V, Ta=25°C)

No.	Item	Conditions	SW conditions							Min.	Typ.	Max.	Unit	
			S1	S2	S3	S4	S5	S6	S7					
1	No signal current	Vin=GND			O				O		1.6	3.35	5.1	mA
2	Lch gain	Vin=2Vrms, f=1kHz			O						- 3	0	3	dB
3	Rch gain	↓			O			O	O		- 3	0	3	dB
4	Channel balance	Lch gain - Rch gain	—	—	—	—	—	—	—		- 3	0	3	dB
5	Lch total harmonic distortion	Vin=2Vrms, f=1kHz			O						—	0.07	0.1	%
6	Rch total harmonic distortion	↓			O			O	O		—	0.07	0.1	%
7	Lch noise level	Vin=GND			O				O		—	- 90	- 80	dBm
8	Rch noise level	↓			O				O	O	—	- 90	- 80	dBm
9	Channel separation	Vin=2Vrms, f=1kHz			O				O	O	55	63	—	dB

O···indicates "ON".

Electrical Characteristics Measurement Circuit

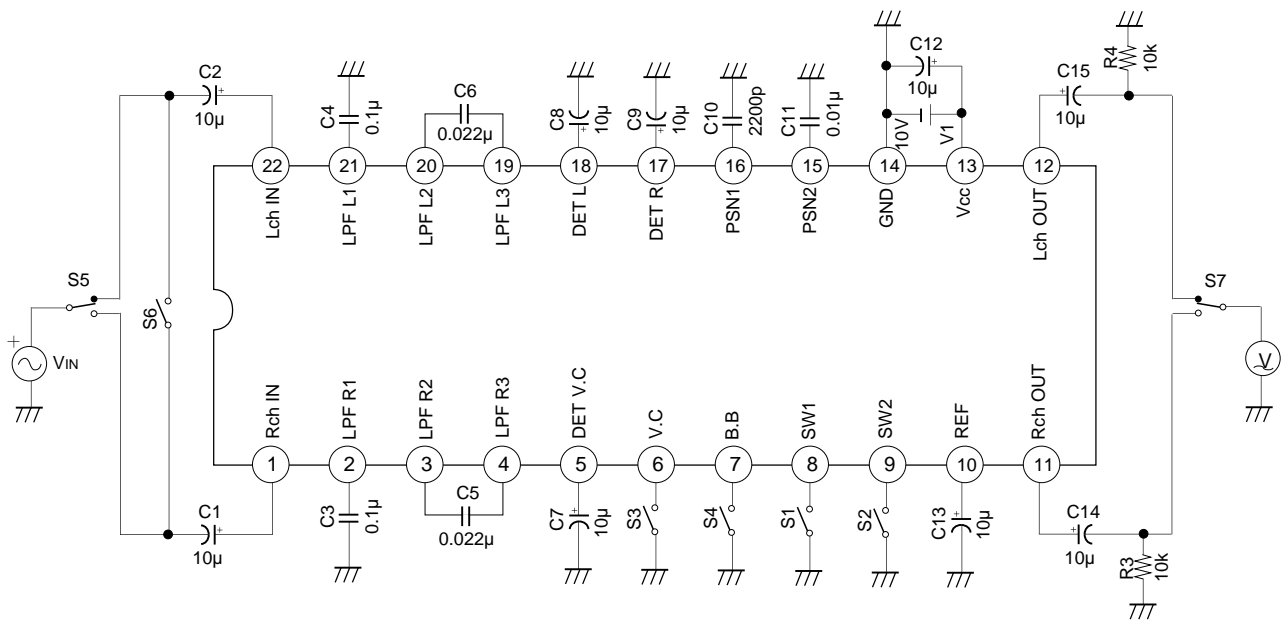

Application Circuit

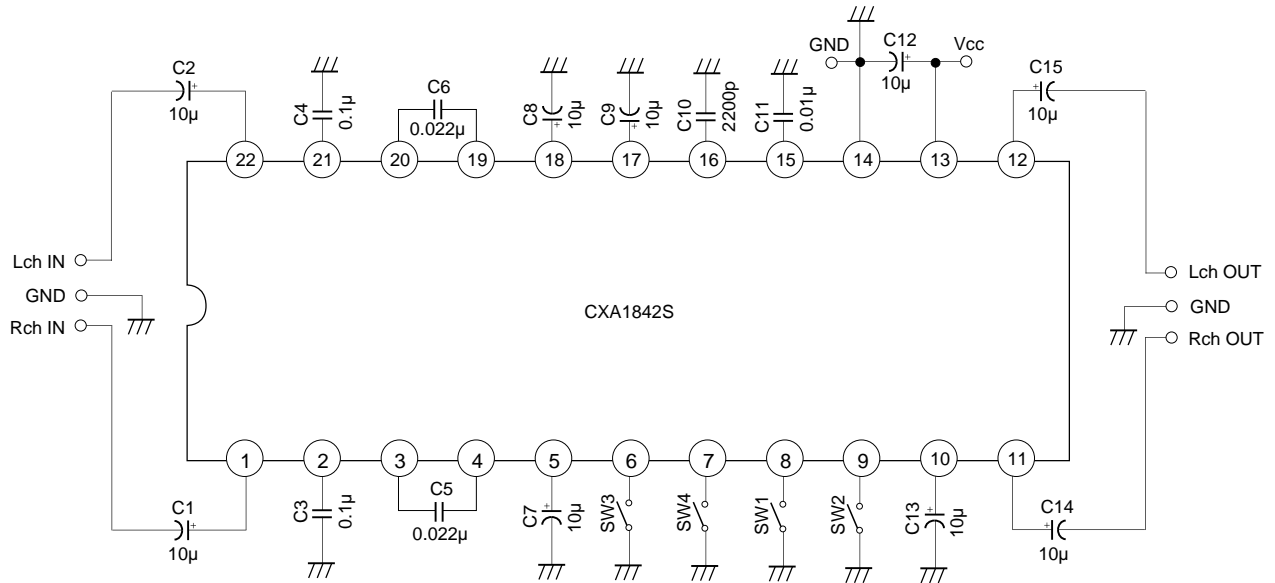

Application circuits shown are typical examples illustrating the operation of the devices. Sony cannot assume responsibility for any problems arising out of the use of these circuits or for any infringement of third party patent and other right due to same.

Mode Switch Correspondence

No.	MODE	SW1	SW2	SW3
1	Simulated Stereo	ON	ON	ON
2	Surround A	ON	OFF	ON
3	Surround B	OFF	ON	ON
4	Pass	OFF	OFF	ON
5	Vocal cancel	—	—	OFF

— don't care

Bass boosting ON when SW4=ON (Invalid during vocal cancellation)

V<sub>TH</sub> for SW ... V<sub>TH</sub> (H) = V<sub>CC</sub> to 3 V, V<sub>TH</sub> (L) = 2 V to GND

**Description of Functions****(1) Simulated Stereo**

The sum of the L and R signals is input to the Simulated Stereo\* (hereafter S.S) block, and a simulated stereo signal is generated.

**(2) Surround A (matrix surround)**

The difference of the L and R signals is raised in level by the VCA (maximum 18 dB (typ.)), and is added to the raw signal.

**(3) Surround B**

The difference of the L and R signals is raised in level by the VCA (maximum 18 dB (typ.)), is input to the S.S block, and is then added to the raw signal.

**(4) Pass**

The L and R signals are output without modification.

**(5) Vocal Cancellation**

The difference of the L and R signals is input to the S.S block after first passing through the AGC circuit, and is then output to L and R. In contrast with conventional products, the vocal cancel signal (L-R signal) is raised in level by the VCA (max. 12 dB typ.), and low frequency part is enhanced, to prevent reduction in the acoustic pressure level when vocal cancellation is ON.

**\* Simulated Stereo circuit:**

Phases in the audio band are divided into two separate orthogonal channels and treated as L+R and L-R signals, and are added and subtracted to produce simulated L and R signals. All-pass network.

Surround Frequency response

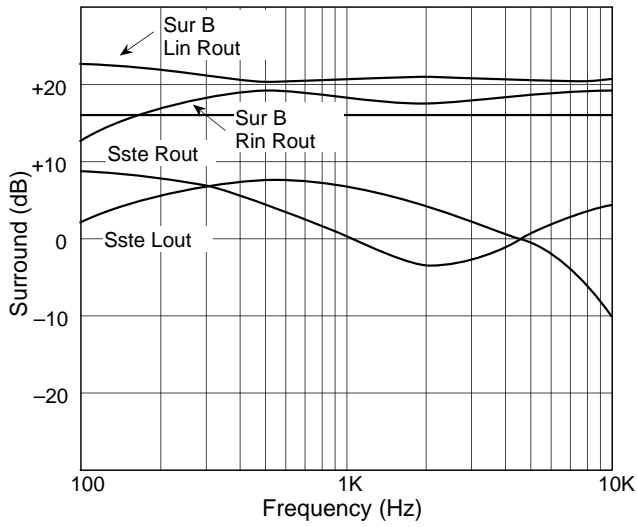

Vocal cancellation Frequency response

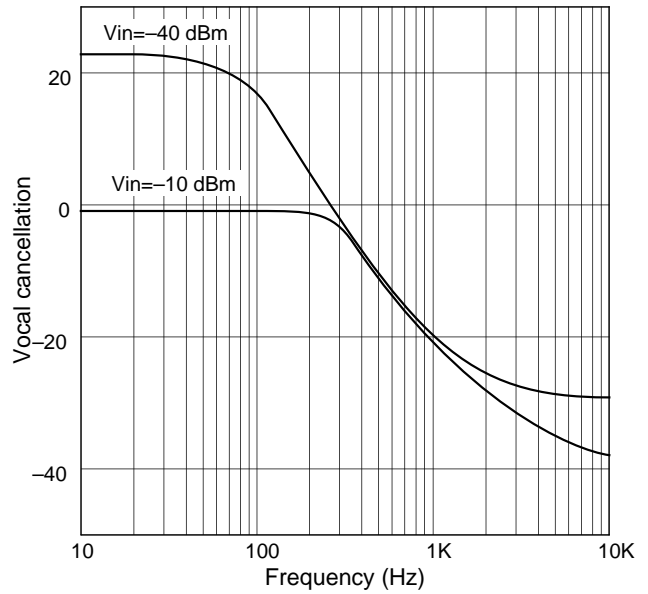

Bass boosting Frequency response

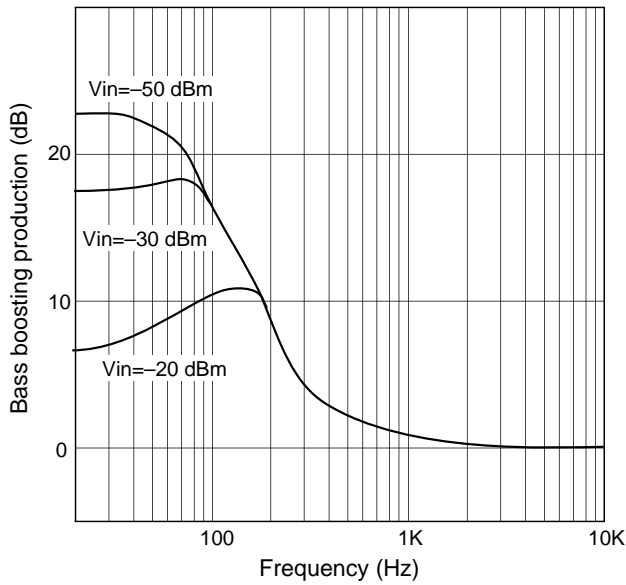

Input/Output Characteristic

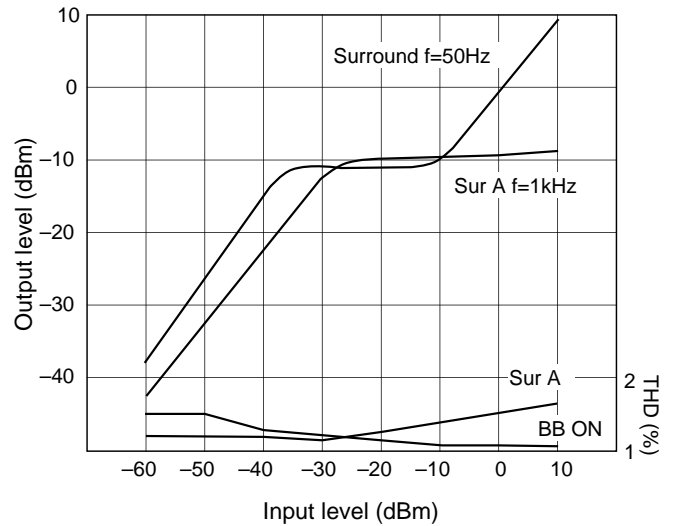

Supply voltage vs. Current consumption

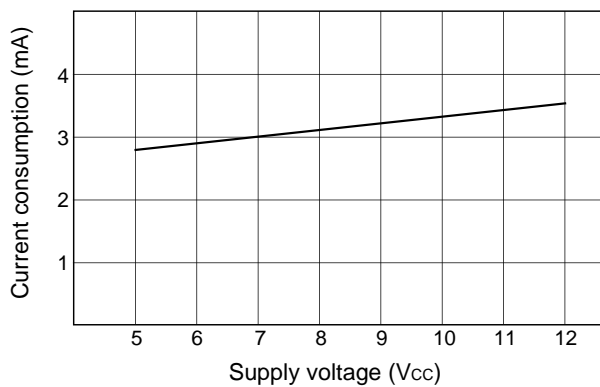

Package Outline Unit : mm

22PIN SDIP (PLASTIC)

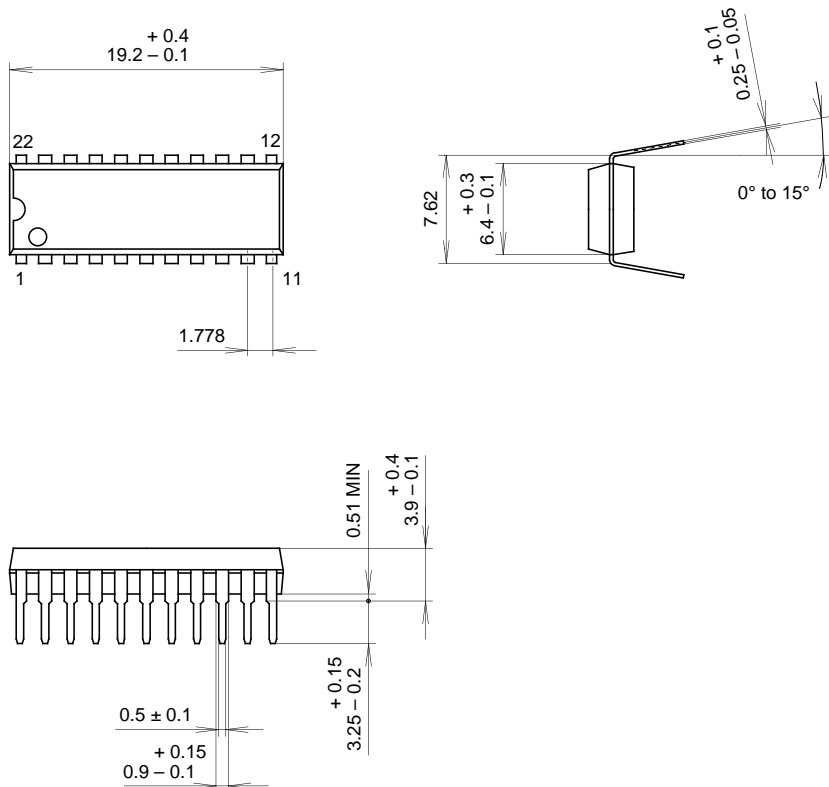

PACKAGE STRUCTURE

SONY CODE	SDIP-22P-01
EIAJ CODE	SDIP022-P-0300
JEDEC CODE	_____

MOLDING COMPOUND	EPOXY RESIN
LEAD TREATMENT	SOLDER PLATING
LEAD MATERIAL	COPPER ALLOY
PACKAGE WEIGHT	0.95g