

DELTRON *Components Limited*

3000 lb LEVER PRESS

PRODUCT SPECIFICATION

Sheet No. **PS 0086**

Date : 26.06.95

Issue No. 1

Sheet 1 of 1

Signature

Deltron Part No. **900-0000**

149 343

Dimensions

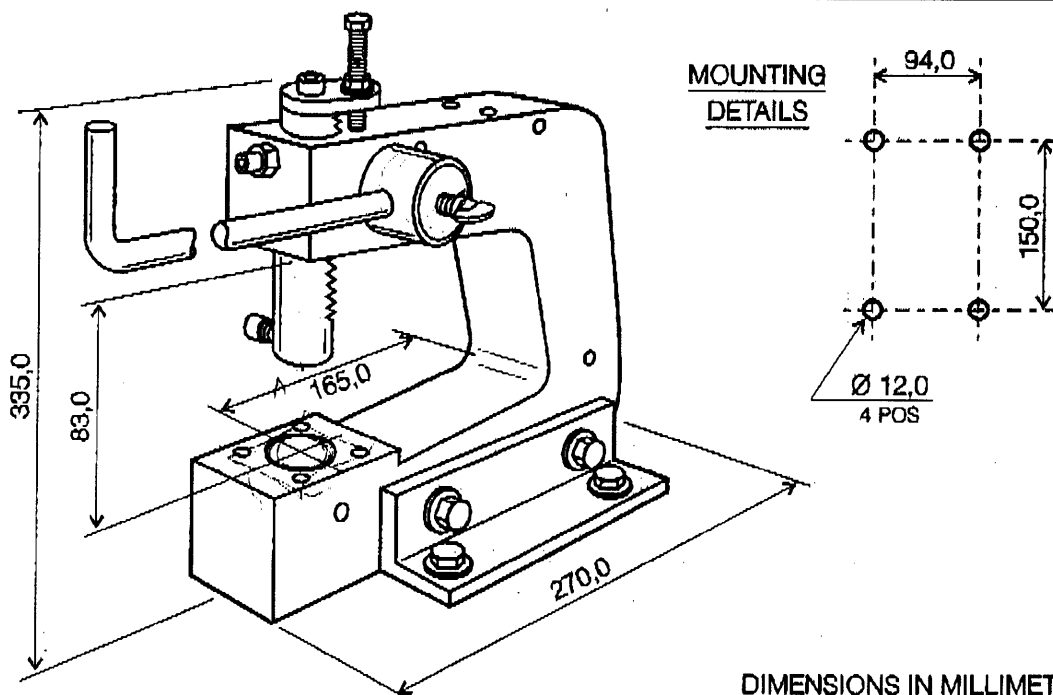

DIMENSIONS IN MILLIMETRES

Description

A bench mounting, hand operated lever press, which together with a variety of punching, cutting and forming tool accessories, provides a universal service for sheet metal working in both workshop and production environments.

Constructed from high quality carbon steel, with a stove enamel finish, and precision machined rack and pinion, a constant pressure through the complete stroke up to 3000lbs is achievable. Easy to set up and operate, the press features an adjustable screw to limit the ram downwards movement, and a lever with lockable length and angle adjustment.

Features

LENGTH (overall)	: 270mm
HEIGHT (max excl lever)	: 335mm
WIDTH (incl mtg brackets)	: 165mm
HANDLE LENGTH	: 550mm
THROAT DEPTH	: 150mm
CLEARANCE	: 83mm
STROKE LENGTH	: 6 to 60mm
RAM SPIGOT HOLE DIA.	: 18mm
DEPTH	: 22mm
BASE CENTRAL HOLE DIA.	: 38mm
MOUNTING HOLES	: 4 x 12mm
PRESS WEIGHT	: 14,5 Kg
CAPACITY	
FIBREGLASS	: 2,0mm
PAPER PCB (s.r.b.p.)	: 3,2mm
ALUMINIUM	: 2,5mm
MILD STEEL	: 1,8mm