

# W91360N SERIES



## 3-MEMORY TONE/PULSE DIALER WITH HANDFREE AND HOLD FUNCTIONS

### GENERAL DESCRIPTION

The W91360N series are tone/pulse switchable telephone dialers with three memories, hold function, and a handfree dialing control circuit. Fabricated using CMOS technology, the W91360N series offer good performance in low-voltage and low-power applications.

### FEATURES

- DTMF/pulse switchable dialer
- Two by 32-digit redial and save memory
- Three by 16-digit one-touch direct repertory memory
- Cascaded dialing allowed, with unlimited dialing length
- Pulse-to-tone (\*T) keypad for long distance call operation
- Uses 5 × 5 keyboard
- Easy operation with redial, flash, pause and \*/T keypads
- Pause, P→T (pulse-to-tone) can be stored as a digit in memory
- On-hook debounce time: 150 msec.
- Minimum tone output duration: 93 msec.
- Minimum intertone pause: 93 msec.
- Flash break time (73, 100, 300, 600 msec) selectable by keypad; pause time is 1.0 sec.
- On-chip power-on reset
- Uses 3.579545 MHz crystal or ceramic resonator
- Packaged in 18 or 20-pin plastic DIP
- The different dialers in the W91360N series are shown in the following table:

TYPE NO.	REPLACEMENT TYPE NO.	PULSE (ppS)	FLASH (mS)	M/B	HANDFREE DIALING	PACKAGE (PINS)
W91360N	W91360	10	600/300/73/100	Pin	-	18
W91360AN	W91360A	10	600/300/73/100	Pin	Yes	20

# W91360N SERIES



## PIN CONFIGURATIONS

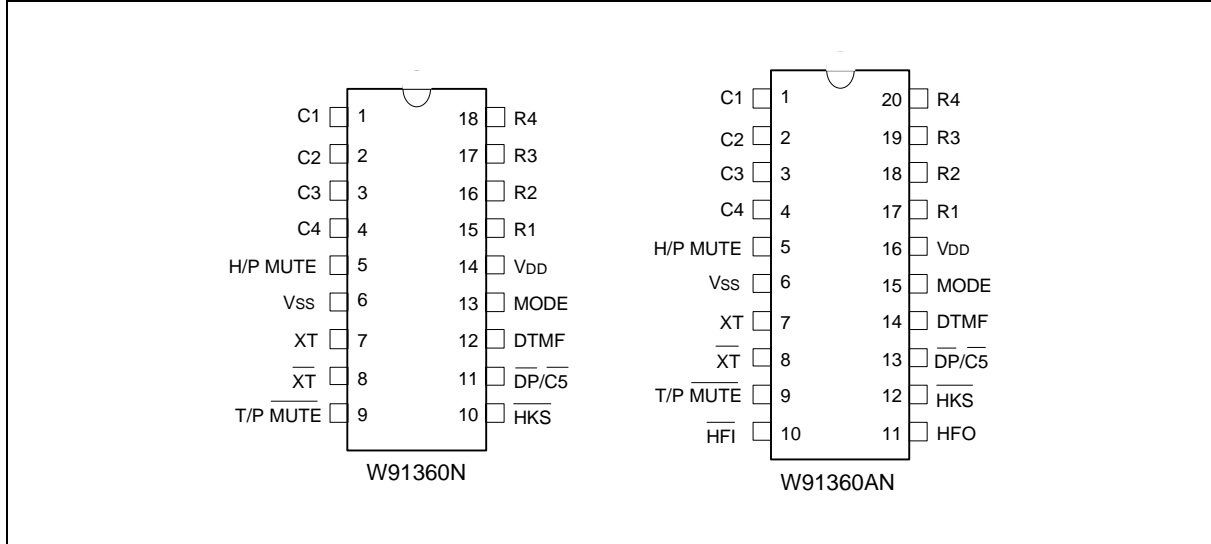

## PIN DESCRIPTION

SYMBOL	18-PIN	20-PIN	I/O	FUNCTION
Column-Row Inputs	1-4 & 15-18	1-4 & 17-20	I	The keyboard inputs may be used with either a standard 5 × 5 keyboard or an inexpensive single contact (Form A) keyboard. Electronic input from a $\mu\text{C}$ can also be used. A valid key is defined as a single row being connected to a single column.
XT, $\overline{\text{XT}}$	7, 8	7, 8	I, O	A built-in inverter provides oscillation with an inexpensive 3.579545 MHz crystal or ceramic resonator.
T/P MUTE	9	9	O	The T/P MUTE is a conventional CMOS N-channel open drain output. The output transistor is switched on during dialing sequence and flash break time. Otherwise, it is switched off.
MODE	13	15	I	Pulling mode pin to V <sub>SS</sub> places the dialer in tone mode. Pulling mode pin to V <sub>DD</sub> places the dialer in pulse mode (M/B = 40:60). Floating mode pin places the dialer in pulse mode (M/B = 33.3:66.7).
$\overline{\text{HKS}}$	10	12	I	Hook switch input. $\overline{\text{HKS}} = \text{V}_{\text{DD}}$ : On-hook state. Chip in sleeping mode, no operation. $\overline{\text{HKS}} = \text{V}_{\text{SS}}$ : Off-hook state. Chip enabled for normal operation. $\overline{\text{HKS}}$ pin is pulled to V <sub>DD</sub> by an internal resistor.

# W91360N SERIES



Pin Description, continued

SYMBOL	18-PIN	20-PIN	I/O	FUNCTION																																								
$\overline{DP}/\overline{C5}$	11	13	O	N-channel open drain dialing pulse output. Flash key will cause $\overline{DP}$ to be active in either tone mode or pulse mode. The timing diagram for pulse mode is shown in Figure 1(a, b, c).																																								
VDD, VSS	14, 6	16, 6	I	Power input pins.																																								
DTMF	12	14	O	In pulse mode, this pin remains in low state at all times. In tone mode, it will output a dual or single tone. Detailed timing diagram for tone mode is shown in Figure 2(a, b, c). <table border="1" style="margin-left: auto; margin-right: auto;"> <thead> <tr> <th colspan="4">OUTPUT FREQUENCY</th> </tr> <tr> <th></th> <th>Specified</th> <th>Actual</th> <th>Error %</th> </tr> </thead> <tbody> <tr> <td>R1</td> <td>697</td> <td>699</td> <td>+0.28</td> </tr> <tr> <td>R2</td> <td>770</td> <td>766</td> <td>-0.52</td> </tr> <tr> <td>R3</td> <td>852</td> <td>848</td> <td>-0.47</td> </tr> <tr> <td>R4</td> <td>941</td> <td>948</td> <td>+0.74</td> </tr> <tr> <td>C1</td> <td>1209</td> <td>1216</td> <td>+0.57</td> </tr> <tr> <td>C2</td> <td>1336</td> <td>1332</td> <td>-0.30</td> </tr> <tr> <td>C3</td> <td>1477</td> <td>1472</td> <td>-0.34</td> </tr> </tbody> </table>	OUTPUT FREQUENCY					Specified	Actual	Error %	R1	697	699	+0.28	R2	770	766	-0.52	R3	852	848	-0.47	R4	941	948	+0.74	C1	1209	1216	+0.57	C2	1336	1332	-0.30	C3	1477	1472	-0.34				
OUTPUT FREQUENCY																																												
	Specified	Actual	Error %																																									
R1	697	699	+0.28																																									
R2	770	766	-0.52																																									
R3	852	848	-0.47																																									
R4	941	948	+0.74																																									
C1	1209	1216	+0.57																																									
C2	1336	1332	-0.30																																									
C3	1477	1472	-0.34																																									
$\overline{HFI}$ , HFO	-	10, 11	I, O	Handfree control pins. The handfree control state is toggled by a low pulse on the $\overline{HFI}$ input pin. The status of the handfree control state is described in the following table: <table border="1" style="margin-left: auto; margin-right: auto;"> <thead> <tr> <th colspan="2">CURRENT STATE</th> <th colspan="3">NEXT STATE</th> </tr> <tr> <th>Hook SW.</th> <th>HFO</th> <th>Input</th> <th>HFO</th> <th>Dialing</th> </tr> </thead> <tbody> <tr> <td>-</td> <td>Low</td> <td><math>\overline{HFI}</math> </td> <td>High</td> <td>Yes</td> </tr> <tr> <td>On Hook</td> <td>High</td> <td><math>\overline{HFI}</math> </td> <td>Low</td> <td>No</td> </tr> <tr> <td>Off Hook</td> <td>High</td> <td><math>\overline{HFI}</math> </td> <td>Low</td> <td>Yes</td> </tr> <tr> <td>On Hook</td> <td>-</td> <td>Off Hook</td> <td>Low</td> <td>Yes</td> </tr> <tr> <td>Off Hook</td> <td>Low</td> <td>On Hook</td> <td>Low</td> <td>No</td> </tr> <tr> <td>Off Hook</td> <td>High</td> <td>On Hook</td> <td>High</td> <td>Yes</td> </tr> </tbody> </table> <p><math>\overline{HFI}</math> pin is pulled to VDD by an internal resistor. Detailed timing diagram is shown in Figure 3.</p>	CURRENT STATE		NEXT STATE			Hook SW.	HFO	Input	HFO	Dialing	-	Low	$\overline{HFI}$	High	Yes	On Hook	High	$\overline{HFI}$	Low	No	Off Hook	High	$\overline{HFI}$	Low	Yes	On Hook	-	Off Hook	Low	Yes	Off Hook	Low	On Hook	Low	No	Off Hook	High	On Hook	High	Yes
CURRENT STATE		NEXT STATE																																										
Hook SW.	HFO	Input	HFO	Dialing																																								
-	Low	$\overline{HFI}$	High	Yes																																								
On Hook	High	$\overline{HFI}$	Low	No																																								
Off Hook	High	$\overline{HFI}$	Low	Yes																																								
On Hook	-	Off Hook	Low	Yes																																								
Off Hook	Low	On Hook	Low	No																																								
Off Hook	High	On Hook	High	Yes																																								
H/P MUTE	5	5	O	The H/P MUTE is a conventional inverter output. During pulse dialing, flash break or hold period, this output is active high; otherwise, it remains in low state.																																								

## BLOCK DIAGRAM

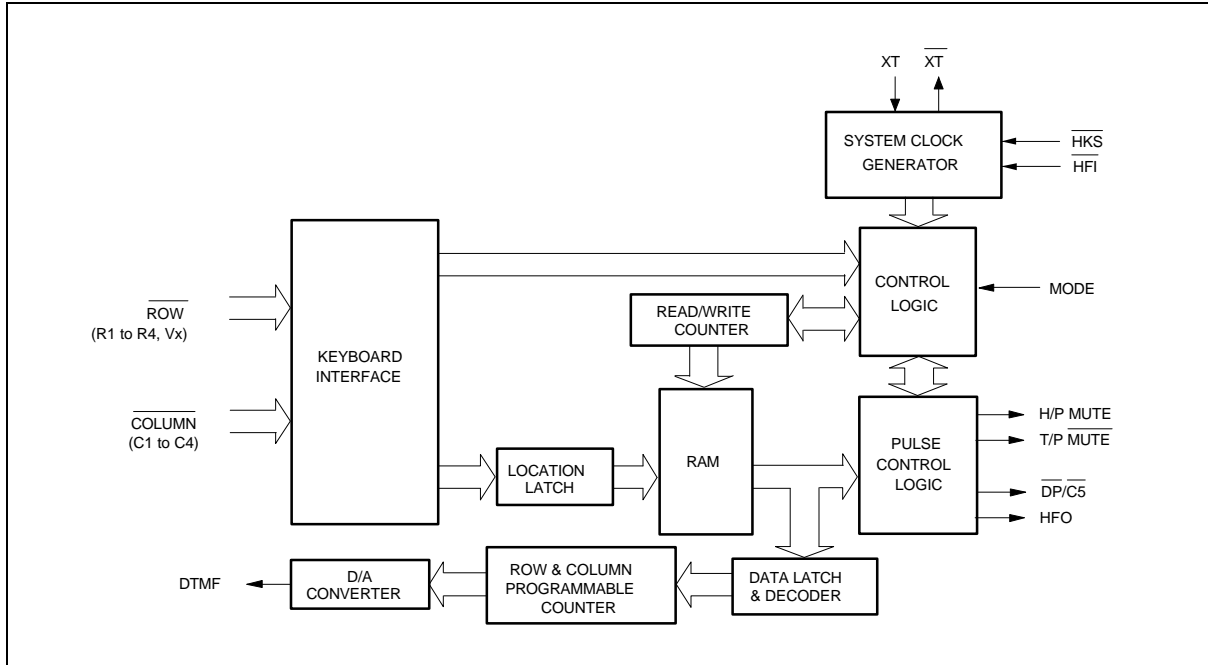

## FUNCTIONAL DESCRIPTION

### Keyboard Operation

C1	C2	C3	C4	$\overline{DP}/\overline{C5}$	
1	2	3	S	M1	R1
4	5	6	F4	M2	R2
7	8	9		M3	R3
*/T	0	#	R/P	SAVE	R4
F1	F2	F3	H		Vx

- S: Store function key
- H: Hold function key
- R/P: Redial and pause function key
- SAVE: Save function key
- \*/T: \* in tone mode and P→T in pulse mode
- M1, ..., M3: One-touch memory
- F1, ..., F4: Flash keys, F1 = 600 mS, F2 = 300 mS, F3 = 73 mS, F4 = 100 mS

#### Notes:

D1, ..., Dn, D1', ..., Dn' : 0, ..., 9, \*/T, #

Mn: M1, ..., M3 ; Fn: F1, ..., F4



## Normal Dialing

, (or  &  ),  ,  , ...,

1. D1, D2, ..., Dn will be dialed out.
2. Dialing length is unlimited, but redial is inhibited if length oversteps 32 digits in normal dialing.

## Redialing

, (or  &  ),  ,  , ...,  Busy, Come  
 ,  , (or  &  ),

1. The redial memory content will be dialed out.
2. The  key can execute the redial function only as the first key-in after off-hook; otherwise, it executes the pause function.
3. If redialing length oversteps 32 digits, the redialing function will be inhibited.

## Number Store

, (or  &  ),  ,  , ...,  ,  ,  ,

1. D1, D2, ..., Dn will be stored in memory location and dialed out.

, (or  &  ),  ,  ,  , ...,  ,  ,

2. D1, D2, ..., Dn will be stored in memory location but will not be dialed out.
3.  and  keys can be stored as a digit in memory.

In store mode,  is the pause function key.

4. The store mode is released after the store function is executed or when the state of the hook switch is changed.

## Repertory Dialing

, (or  &  ),

## Access Pause

, (or  &  ),  ,  ,  ,  , ...,

1. The pause function can be stored as a digit in memory.
2. The pause function is executed in normal dialing, redial dialing, or memory dialing.
3. The detailed timing diagram for the pause function is shown in Figure 4.

## Pulse-to-tone (\*T)

# W91360N SERIES



OFF HOOK , (or  ON HOOK &   $\overline{\text{HF1}} \overline{\text{i}\hat{\text{o}}}$  ),  D1 ,  D2 , ...,  Dn ,  \*/T ,  D1' ,  D2' , ...,  Dn'

1. If the mode switch is set to pulse mode, then the output signal will be:  
D1, D2, ..., Dn, Pause (3.6 sec.), D1', D2', ..., Dn'  
(Pulse) (Tone)
2. If the mode switch is set to tone mode, then the output signal will be as follows:  
D1, D2, ..., Dn, \*, D1', D2', ..., Dn'  
(Tone) (Tone)
3. The dialer remains in tone mode when the digits have been dialed out and can be reset to pulse mode only by going on-hook.
4. The pulse-to-tone function timing diagram is shown in Figure 5.

## Flash

OFF HOOK , (or  ON HOOK &   $\overline{\text{HF1}} \overline{\text{i}\hat{\text{o}}}$  ),  Fn

1. Fn = F1, ..., F4
2. The dialer will execute a flash break time of 600 mS (F1), 300 mS (F2), 73 mS (F3), or 100 mS (F4).  
In each case, the flash pause time is 1.0 sec. before the next digit is dialed out.
3. Flash key cannot be stored as a digit in memory, and it has first priority among keyboard functions.
4. The system will return to the initial state after the flash pause time is finished.
5. The flash function timing diagram is shown in Figure 6.

## Save

OFF HOOK , (or  ON HOOK &   $\overline{\text{HF1}} \overline{\text{i}\hat{\text{o}}}$  ),  D1 ,  D2 , ...,  Dn ,  SAVE

1. If the dialing  D1 to  Dn is finished, pressing the  SAVE key will cause D1 to Dn to be copied to the save memory.

OFF HOOK , (or  ON HOOK &   $\overline{\text{HF1}} \overline{\text{i}\hat{\text{o}}}$  ),  SAVE

2. D1 to Dn will be dialed out after the save key is pressed.

## Cascaded Dialing

1.  Normal Dialing +  Repertory Dialing +  Normal Dialing
2.  Repertory Dialing +  Normal Dialing +  Repertory Dialing

# W91360N SERIES



3. Redialing + Normal Dialing + Repertory Dialing

Redialing and save dialing are valid as first key-in only.

## ABSOLUTE MAXIMUM RATINGS

PARAMETER	SYMBOL	RATING	UNIT
DC Supply Voltage	VDD-VSS	-0.3 to +7.0	V
Input/Output Voltage	VIL	VSS -0.3	V
	VIH	VDD +0.3	V
	VOL	VSS -0.3	V
	VOH	VDD +0.3	V
Power Dissipation	PD	120	mW
Operation Temperature	TOPR	-20 to +70	°C
Storage Temperature	TSTG	-55 to +150	°C

Note: Exposure to conditions beyond those listed under Absolute Maximum Ratings may adversely affect the life and reliability of the device.

## DC CHARACTERISTICS

(VDD-VSS = 2.5V, Fosc. = 3.579545 MHz, TA = 25° C, all outputs unloaded)

PARAMETER	SYMBOL	CONDITIONS	MIN.	TYP.	MAX.	UNIT
Operating Voltage	VDD	-	2.0	-	5.5	V
Operating Current	IOP	Tone, Unloaded	-	0.4	0.6	mA
		Pulse, Unloaded	-	0.2	0.4	
Standby Current	ISB	$\overline{\text{HKS}} = \text{VSS}$ , No load & No key entry	-	-	15	μA
Memory Retention Current	IMR	$\overline{\text{HKS}} = \text{VDD}$ , VDD = 1.0V	-	-	0.2	μA
DTMF Output Voltage	VTO	Row group, RL = 5 KΩ	130	150	170	mVrms
Pre-emphasis		Col/Row, VDD = 2.0 to 5.5V	1	2	3	dB
DTMF Distortion	THD	RL = 5 KΩ, VDD = 2.0 to 5.5V	-	-30	-23	dB
DTMF Output DC Level	VTDC	RL = 5 KΩ, VDD = 2.0 to 5.5V	1.0	-	3.0	V
DTMF Output Sink Current	ITL	VTO = 0.5V	0.2	-	-	mA
$\overline{\text{DP}}$ Output Sink Current	IPL	VPO = 0.5V	0.5	-	-	mA

# W91360N SERIES



DC Characteristics, continued

PARAMETER	SYMBOL	CONDITIONS	MIN.	TYP.	MAX.	UNIT
T/P MUTE Output Sink Current	IML	V <sub>MO</sub> = 0.5V	0.5	-	-	mA
H/P MUTE Output Drive/Sink Current	IHPH	V <sub>HPH</sub> = 2.0V	0.5	-	-	mA
	IHPL	V <sub>HPL</sub> = 0.5V	0.5	-	-	mA
HFO Drive/Sink Current	IHFH	V <sub>HFH</sub> = 2.0V	0.5	-	-	mA
	IHFL	V <sub>HFL</sub> = 0.5V	0.5	-	-	mA
Keypad Input Drive Current	IKD	V <sub>I</sub> = 0.0V	30	-	-	μA
Keypad Input Sink Current	IKS	V <sub>I</sub> = 2.5V	200	400	-	μA
HKS I/P Pull-High Resistor	RHK	-	-	300	-	KΩ
Keypad Resistance	RK	-	-	-	5.0	KΩ

## AC CHARACTERISTICS

(V<sub>DD</sub>-V<sub>SS</sub> = 2.5V, F<sub>osc</sub> = 3.579545 MHz, T<sub>A</sub> = 25° C, all outputs unloaded)

PARAMETER	SYMBOL	CONDITIONS	MIN.	TYP.	MAX.	UNIT
Key-in Debounce	TKID	-	-	20	-	mS
Key Release Debounce	TKRD	-	-	20	-	mS
On-hook Debounce	TOHD	-	-	150	-	mS
Pre-digit Pause	TPDP 10 ppS	Mode = V <sub>DD</sub>	-	40	-	mS
		Mode = Floating	-	33.3	-	
Interdigit Pause (Auto Dialing)	TIDP	10 ppS	-	800	-	mS
Make/Break Ratio	M/B	Mode = V <sub>DD</sub>	-	40:60	-	%
		Mode = Floating	-	33.3:66.7	-	
Tone Output Duration	TTD	Auto dialing	-	93	-	mS
Intertone Pause	TITP	Auto dialing	-	93	-	mS
Flash Break Time	TFB	F1	-	600	-	mS
		F2	-	300	-	
		F3	-	73	-	
		F4	-	100	-	
Flash Pause Time	TFP	F1, F2, F3, F4	-	1.0	-	S
Pause Time	TP	R/P	-	3.6	-	S

Notes:

- Crystal parameters suggested for proper operation are R<sub>s</sub> < 100 Ω, L<sub>m</sub> = 96 mH, C<sub>m</sub> = 0.02 pF, C<sub>n</sub> = 5 pF, C<sub>l</sub> = 18 pF, F<sub>osc</sub> = 3.579545 MHz ± 0.02%.
- Crystal oscillator accuracy directly affects these times.



## TIMING WAVEFORMS

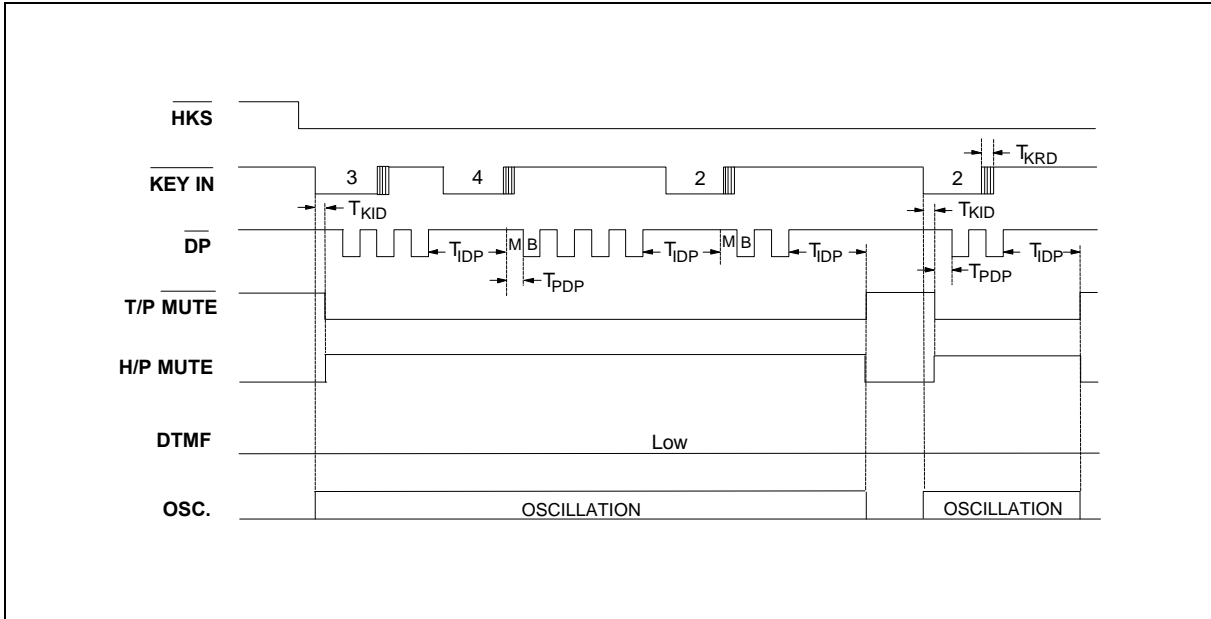

Figure 1(a) Normal Dialing Timing Diagram

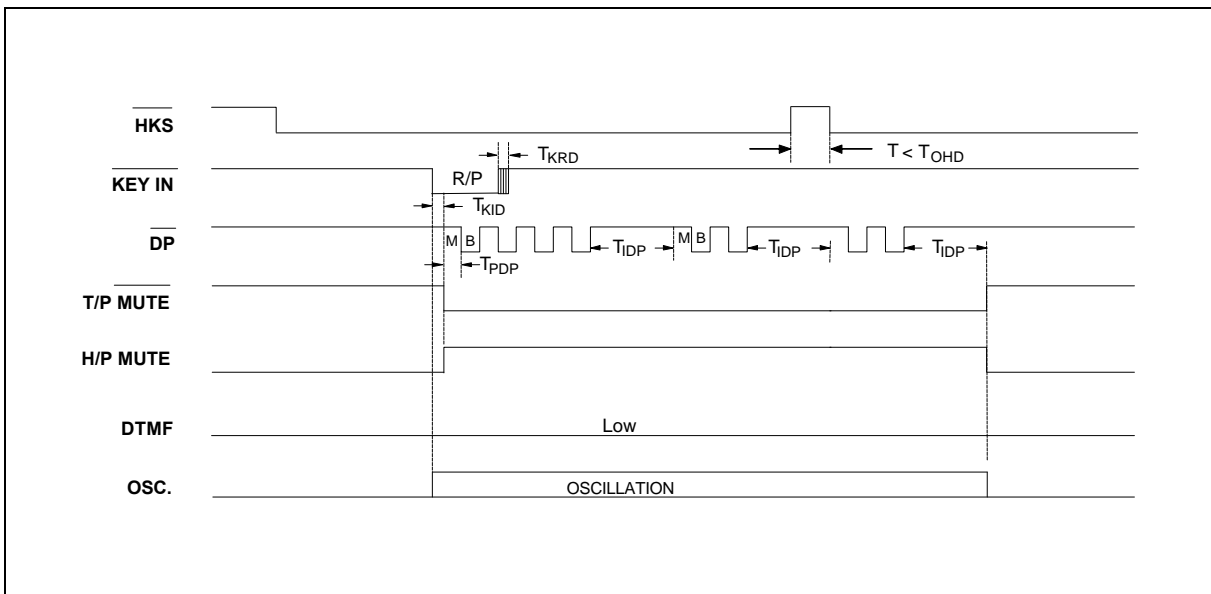

Figure 1(b) Pulse Mode Auto Dialing Timing Diagram



Timing Waveforms, continued

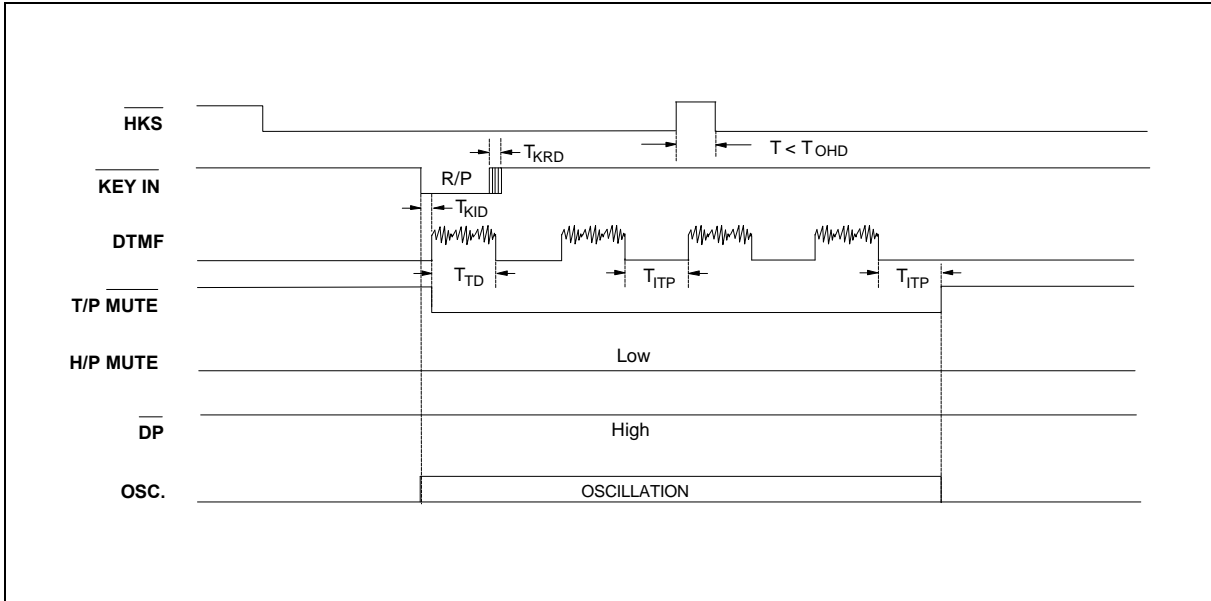

Figure 2(b) Tone Mode Auto Dialing Timing Diagram

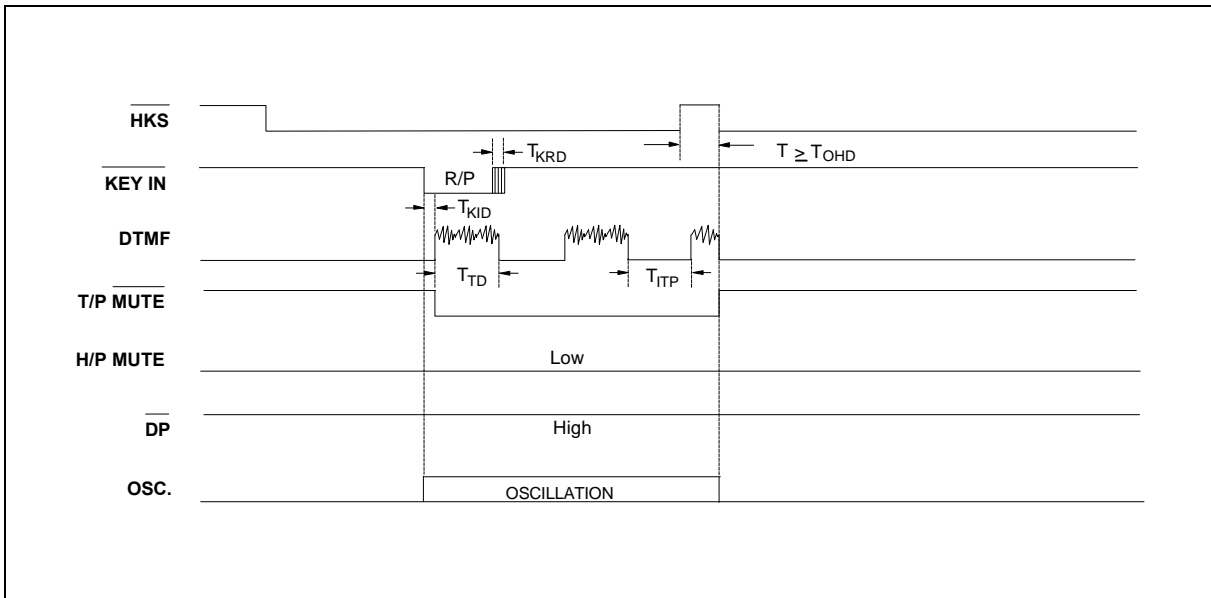

Figure 2(c) Tone Mode Auto Dialing Timing Diagram

# W91360N SERIES



Timing Waveforms, continued

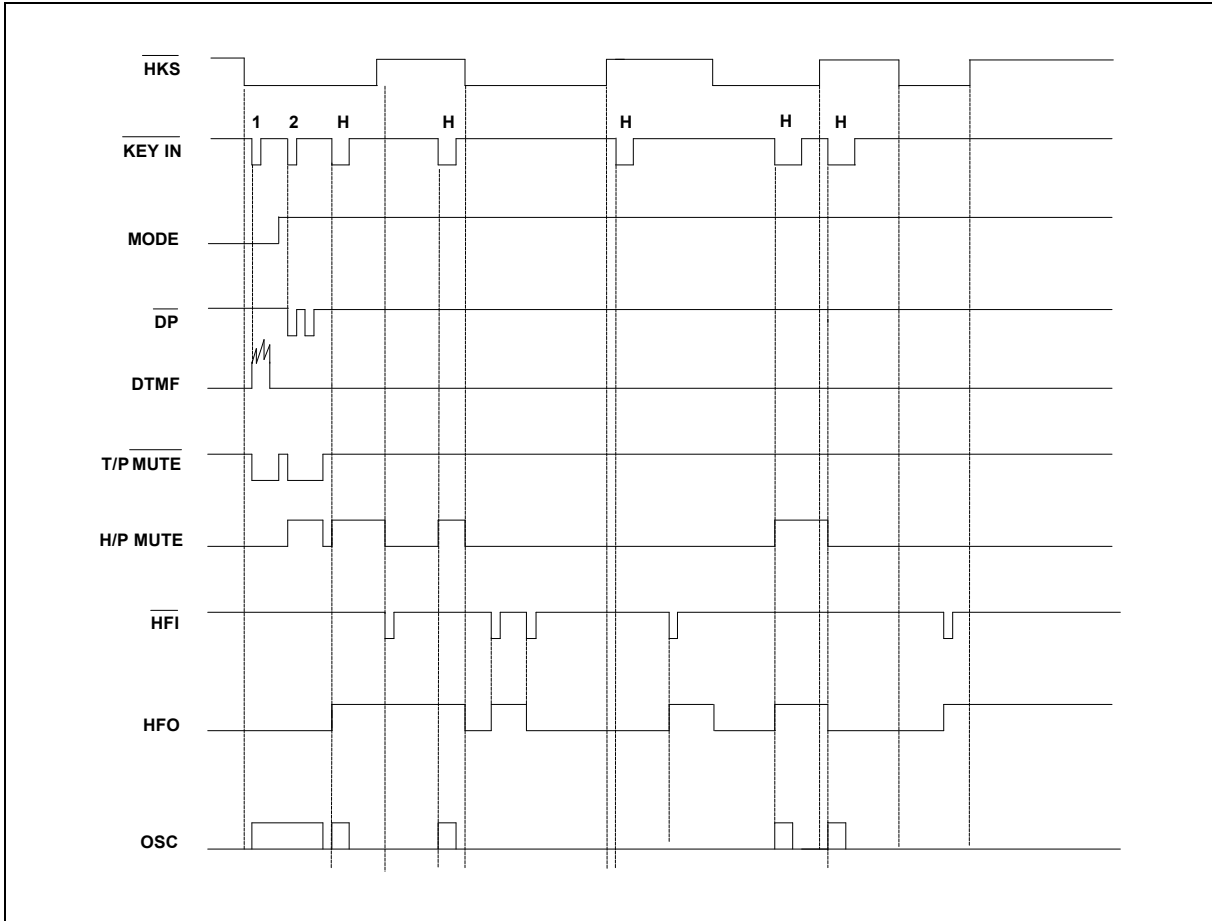

Figure 3. Handfree Function Timing Diagram

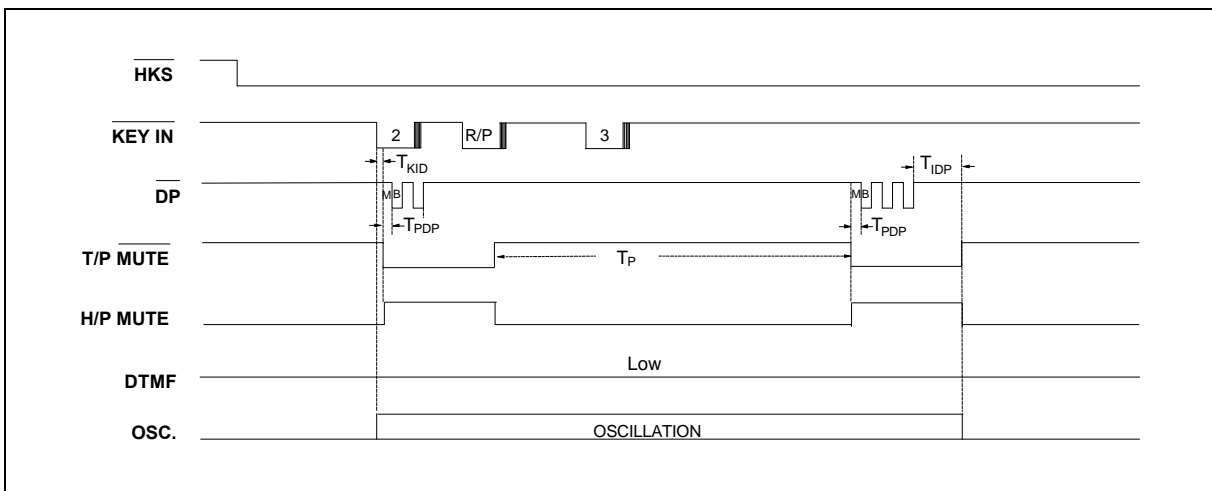

Figure 4. Pause Function Timing Diagram

Timing Waveforms, continued

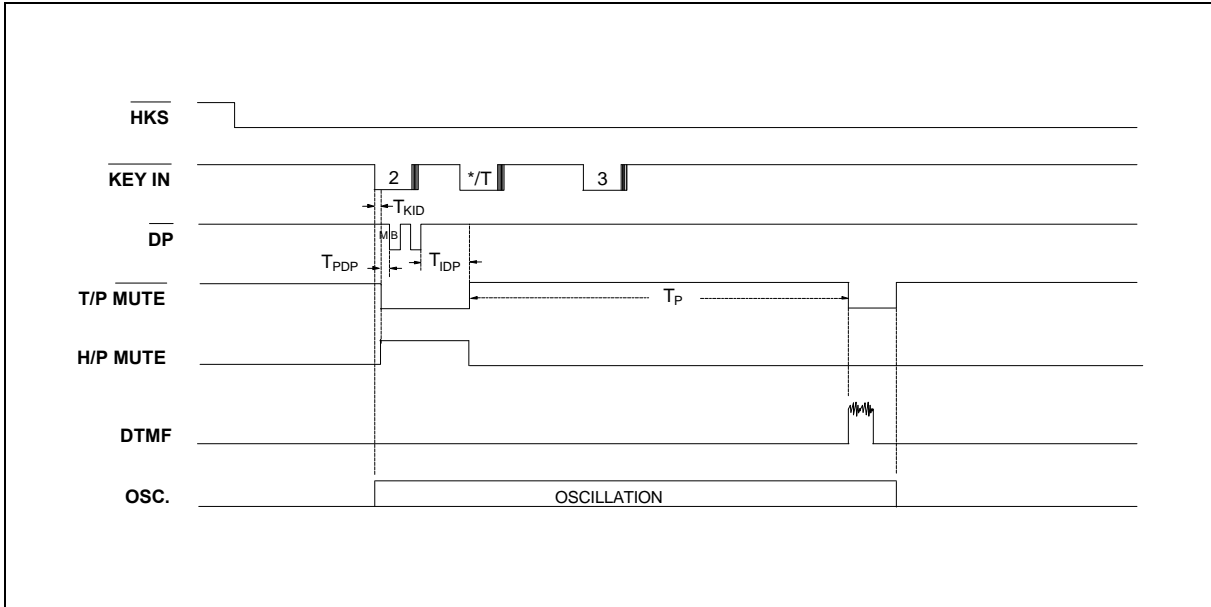

Figure 5. Pulse-to-tone Timing Diagram

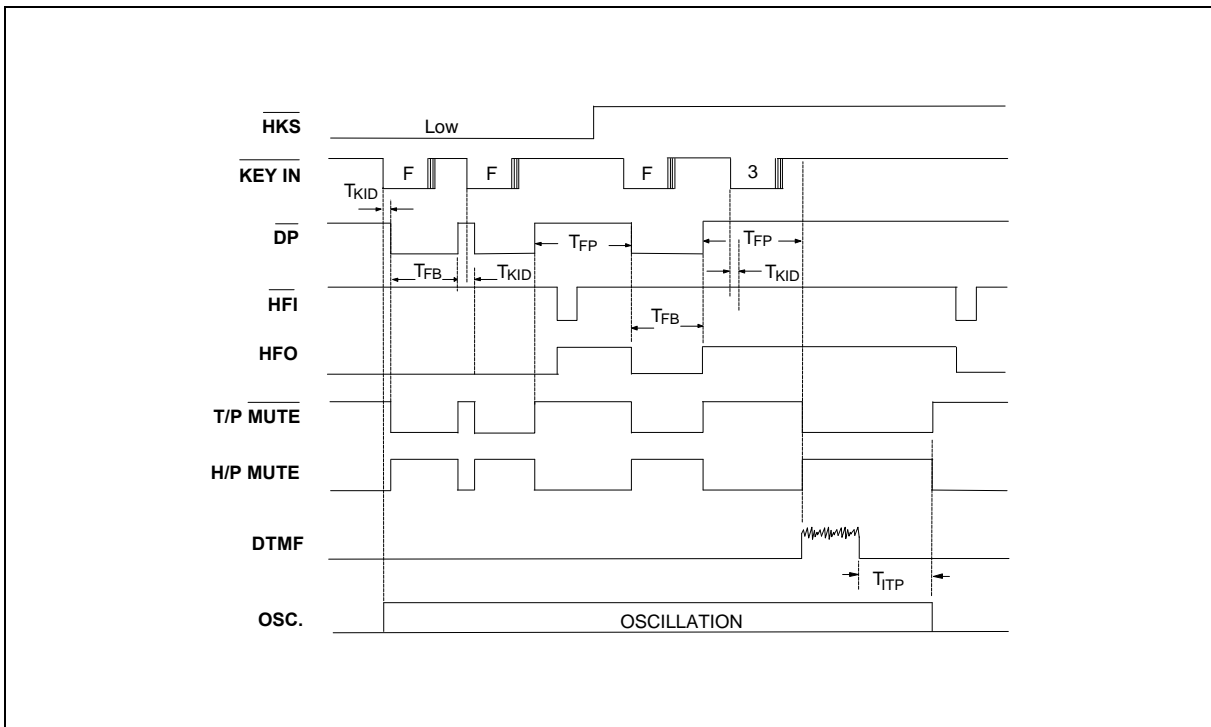

Figure 6. Flash Timing Diagram

# W91360N SERIES



#### Headquarters

No. 4, Creation Rd. III,  
Science-Based Industrial Park,  
Hsinchu, Taiwan  
TEL: 886-3-5770066  
FAX: 886-3-5792697  
<http://www.winbond.com.tw/>  
Voice & Fax-on-demand: 886-2-7197006

#### Taipei Office

11F, No. 115, Sec. 3, Min-Sheng East Rd.,  
Taipei, Taiwan  
TEL: 886-2-7190505  
FAX: 886-2-7197502

#### Winbond Electronics (H.K.) Ltd.

Rm. 803, World Trade Square, Tower II,  
123 Hoi Bun Rd., Kwun Tong,  
Kowloon, Hong Kong  
TEL: 852-27516023  
FAX: 852-27552064

#### Winbond Electronics North America Corp.

**Winbond Memory Lab.**  
**Winbond Microelectronics Corp.**  
**Winbond Systems Lab.**  
2730 Orchard Parkway, San Jose,  
CA 95134, U.S.A.  
TEL: 1-408-9436666  
FAX: 1-408-9436668

---

Note: All data and specifications are subject to change without notice.