

Voltage Variable Absorptive Attenuator 1700 - 2200 MHz

MAAVCC0002

Features

- Input IP₃: +31 dBm Min (Full Attenuation Range)
- Input IP₃ is **15 -20 dB** Better than GaAs
- Linear Operation: +20 dBm Min.
- Plastic, 28 Lead, 6 mm CSP, SMT Package
- 35 dB Dynamic Range (With 30 mA Bias Current)
- Single Control Voltage
- 50 ohm Impedance
- Linear Driver, DR65-0002, Available
- Test Boards are Available
- Tape and Reel Packaging Available

Description

M/A-COM's MAAVCC0002 is a PIN diode based voltage variable attenuator. This device is in a 6mm square, 28 lead, plastic CSP package, suitable for surface mounting on PCBs. These attenuators have linear operating power and input intercept point levels 15 - 20 dB better than GaAs FET MMIC voltage variable attenuators. They are ideally suited for use where low distortion, high linear operating power and high dynamic range are required. These devices are optimized for the PCS and UMTS frequency bands, but exhibit excellent performance and repeatability over the entire specified frequency band. The MAAVCC0002 is ideally suited for wireless communications systems.

CSP-8, 28 Lead, 6mm

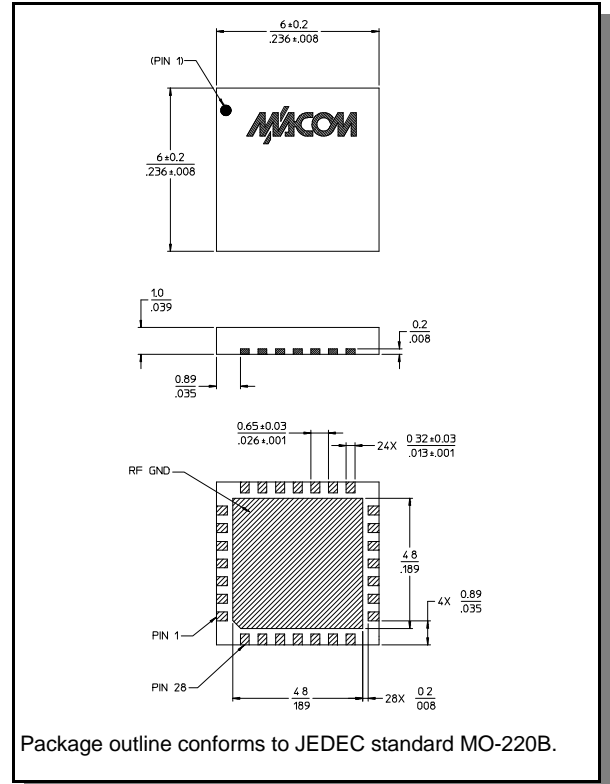

Electrical Specifications: T_A = 25°C

Parameter	Test Conditions	Frequency	Units	Min.	Typ.	Max.
Insertion Loss	0 volts	1700-2200 MHz	dB	—	2.9	4.0
Attenuation (Above Loss)	10 mA bias current	1700-2200 MHz	dB	30	33	—
Frequency Flatness	0 to 30 dB attenuation	1930 - 1990 MHz	dB	—	0.5	0.8
		2000 - 2200 MHz	dB	—	1.0	2.0
VSWR	0 to 30 dB attenuation	1700-2200 MHz	Ratio	—	2:1	2:2
Switching Speed	50% Control to 90%/10% RF	1700-2200 MHz	μS	—	—	3.0
Linear Operation	—	1700-2200 MHz	dBm	—	+20	—
Input IP ₃	Two-tone inputs up to +10 dBm	1700-2200 MHz	dBm	+31	—	—
P1 dB	Full Attenuation Range	1700-2200 MHz	dBm	—	+23	—
I _{Control}	—	1700-2200 MHz	mA	—	—	30

Typical Performance Curves

Insertion Loss

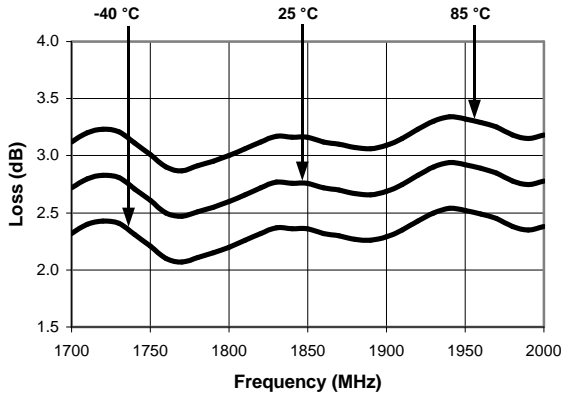

Typical VSWR @ +25°C

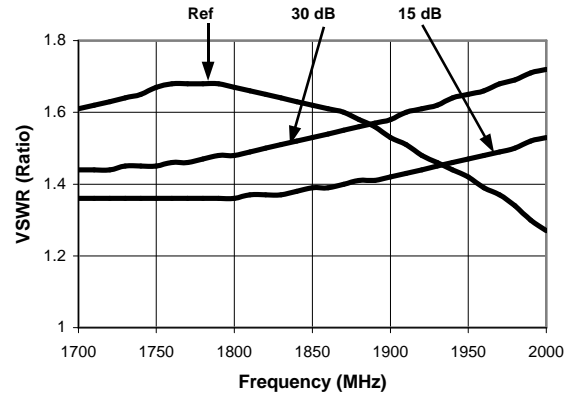

Attenuation Flatness @ +25°C

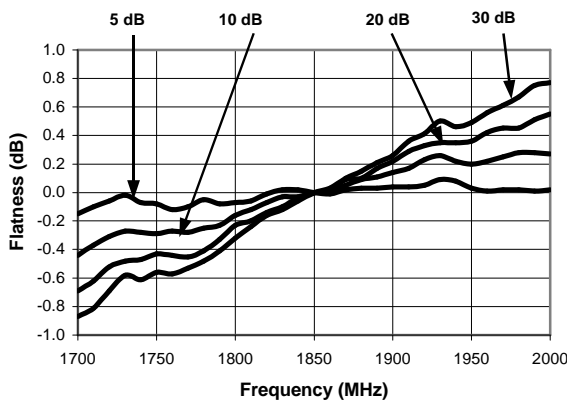

Atten. vs. Bias Current @ +25°C

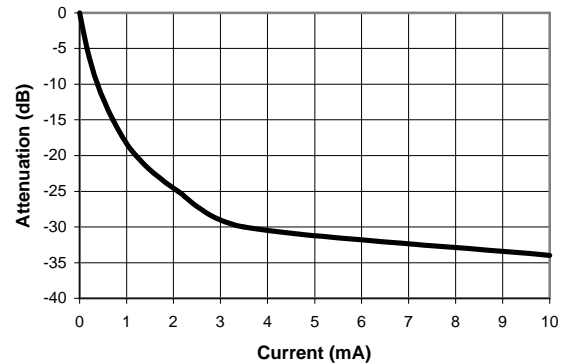

Insertion Loss @ 25°C

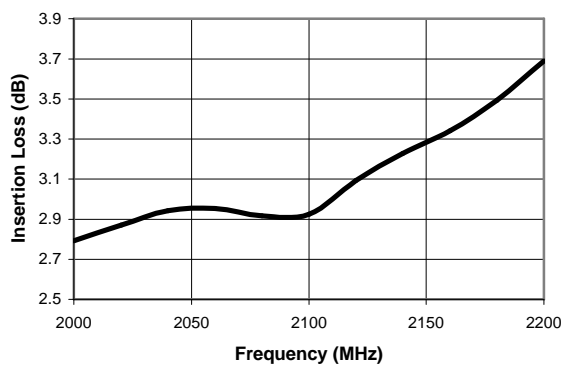

Attenuation Flatness @ 25°C

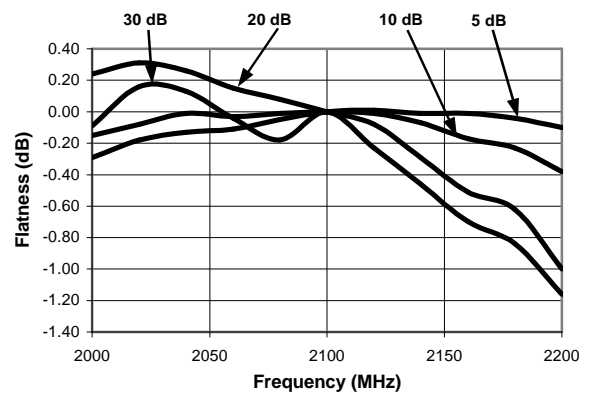

Specifications subject to change without notice.

- North America: Tel. (800) 366-2266
- Asia/Pacific: Tel.+81-44-844-8296, Fax +81-44-844-8298
- Europe: Tel. +44 (1344) 869 595, Fax+44 (1344) 300 020

Visit www.macom.com for additional data sheets and product information.

Typical Performance Curves

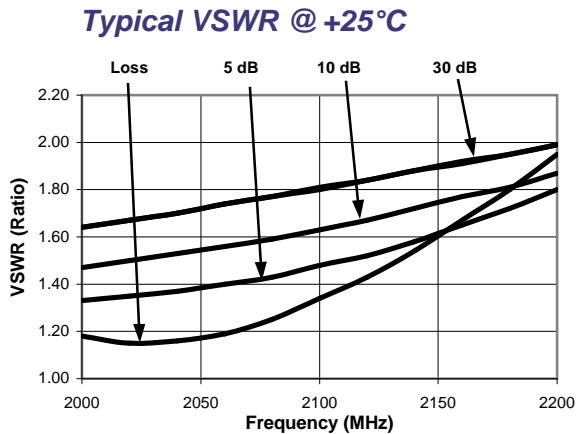

Pin Configuration

Pin #	Function	Pin #	Function
1	N/C	15	N/C
2	N/C	16	N/C
3	N/C	17	N/C
4	N/C	18	N/C
5	N/C	19	N/C
6	N/C	20	N/C
7	N/C	21	N/C
8	N/C	22	N/C
9	Bias ¹	23	N/c
10	N/C	24	Bias ¹
11	N/C	25	N/C
12	GND	26	GND
13	RF out	27	RF in
14	GND	28	GND

1. Bias current may be applied to Pin 9 or 24. However, the unused Pin must be isolated.

Recommended PCB Layout

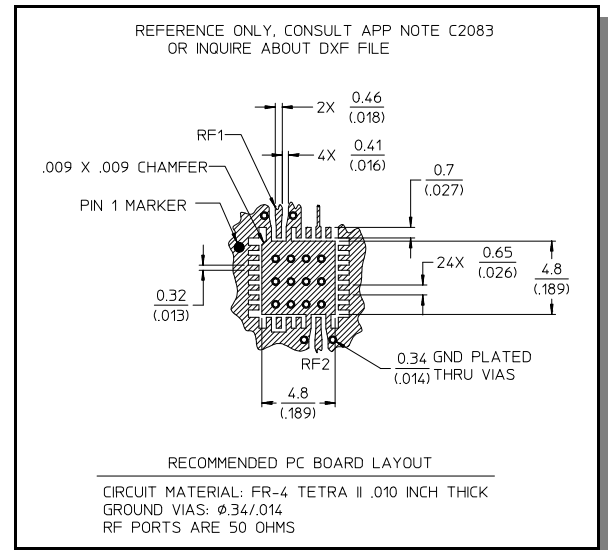

Ordering Information

Part Number	Package
MAAVCC0002	Bulk Packaging
MAAVCC0002TR	Tape and Reel (1K Reel)
MAAVCC0002-TB	Unit Mounted on Test Board

Absolute Maximum Ratings ²

Parameter	Absolute Maximum
Max. Input Power 1700 - 2200 MHz	+27 dBm
Operating Temperature	-40°C to +85°C
Storage Temperature	-65°C to +125°C

2. Operation of this device above any one of these parameters may cause permanent damage.

Specifications subject to change without notice.

- North America: Tel. (800) 366-2266
- Asia/Pacific: Tel.+81-44-844-8296, Fax +81-44-844-8298
- Europe: Tel. +44 (1344) 869 595, Fax+44 (1344) 300 020

Visit www.macom.com for additional data sheets and product information.