

Customer Information Sheet

DRAWING No.: H3191-XX

SHEET 2 OF 2

IF IN DOUBT - ASK

©

NOT TO SCALE

THIRD ANGLE PROJECTION

ALL DIMENSIONS IN mm

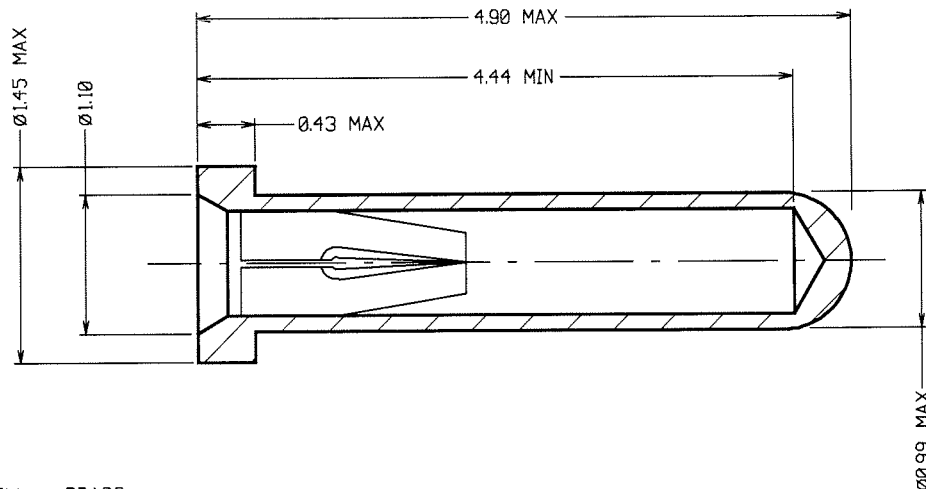

ORDER CODE:

H3191-XX

FINISH:

- 01 = GOLD CLIP, TIN SHELL
- 05 = GOLD CLIP, GOLD SHELL
- 46 = 100% TIN CLIP, TIN SHELL

SPECIFICATION:

MATERIAL:

- CONTACT SHELL - BRASS
- CONTACT CLIP - BERYLLIUM COPPER

FINISH:

- 01 - 0.1µ GOLD CLIP, 4µ TIN SHELL
- 05 - 0.1µ GOLD CLIP, 0.13µ GOLD SHELL
- 46 - 1.3µ 100% TIN CLIP, 4µ TIN SHELL

ELECTRICAL:

- CURRENT RATING AT 25°C = 2A MAX
- CURRENT RATING AT 85°C = 1.75A MAX
- CONTACT RESISTANCE (INITIAL) = 15 MILLIOHMS MAX
- CONTACT RESISTANCE (AFTER CONDITIONING) = 25 MILLIOHMS MAX

MECHANICAL:

- INSERTION FORCE (INITIAL) = 6N MAX, 2N MIN (Ø0.5mm GAUGE)
- WITHDRAWAL FORCE (INITIAL) = 1.5N MAX, 0.5N MIN (Ø0.5mm GAUGE)
- DURABILITY - 01, 05 = 500 OPERATIONS
- 46 = 50 OPERATIONS

ENVIRONMENTAL:

- OPERATING TEMPERATURE = -55°C TO +125°C
- FOR COMPLETE SPECIFICATION, SEE COMPONENT SPECIFICATION C006XX (LATEST ISSUE)

NOTES:

1. RECOMMENDED PIN LENGTH = 2.40-2.30mm.
2. RECOMMENDED MOUNTING HOLE = Ø1.10-1.00mm.
3. RECOMMENDED PIN SIZE = Ø0.51-0.46mm.

JMB	5	12.07.05	8627
NAME	ISS.	DATE	C/NOTE
APPROVED: <i>[Signature]</i>			
CHECKED: <i>[Signature]</i>			
DRAWN: J CLAY		CUSTOMER REF.:	
ASSEMBLY DRG:			

HARWIN

HARWIN USA
TEL: 603 893 5376
FAX: 603 893 5396
mis@harwin.com

HARWIN Europe (UK)
TEL: 023 9231 4545
FAX: 023 9231 4590
mis@harwin.co.uk

HARWIN Asia
TEL: +65 6 779 4909
FAX: +65 6 779 3868
mis@harwin.com.sg

THIS DRAWING AND ANY INFORMATION OR DESCRIPTIVE MATTER SET OUT HEREON ARE CONFIDENTIAL AND COPYRIGHT PROPERTY OF THE HARWIN GROUP AND MUST NOT BE DISCLOSED, LOANED, COPIED OR USED FOR MANUFACTURING, TENDERING OR FOR ANY OTHER PURPOSE WITHOUT THEIR WRITTEN PERMISSION.

TOLERANCES
X. = ±1mm
X.X = ±0.25mm
X.XX = ±0.10mm
X.XXX = ±0.01mm
ANGLES = ±5°
UNLESS STATED

MATERIAL:
SEE ABOVE
FINISH: SEE ABOVE
S/AREA: mm²

TITLE:
SUB-MINIATURE SOCKET ASSEMBLY
DRAWING NUMBER:
H3191-XX
SHT 2 OF 2