

CRYSTAL CLOCK OSCILLATORS

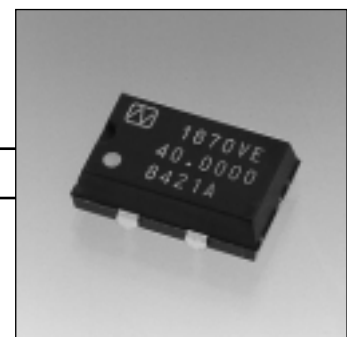

1870XE • 1870YE SERIES

■ Features

- Supply Voltage 3.3V.
- Directly drives C-MOS IC.
- The PLL technology enables this series to cover the frequency range from 1 to 125MHz.
- The frequency writing technology makes quick delivery possible.
- Stand-by function for output (Tri-state output).
- Compact and light weight : height 4.7mm, volume 0.4cm³, weight 1.5g.
- High reliability.
(metal hermetic sealed crystal unit is inhoused)
- Applicable for reflow automatic mounting processes.
- Static electricity proof packaging : tape & reel.

■ **Absolute Maximum Rating**
Supply Voltage (V_{DD}) -0.5~+7.0V DC
Storage Temperature Range -55~+125°C

Item		Model	1870XE	1870YE
Output Level			C-MOS	
Frequency Range	(MHz)		1~125	
Frequency Stability	(×10 ⁻⁶)		±50, ±100	
Operating Temp. Range	(°C)		-20~+70	
Supply Voltage	(V)		3.3V±0.3	
Current Consumption (+3.3V, at 25°C)			28mA (max)	
	stand-by		16mA (max)	50µA (max)
V _{OL} max / V _{OH} min	(V)		0.4/V _{DD} -0.4 I _{OL} =8mA, I _{OH} =-8mA	
Tr max/Tf max	(ns)		3.3 (at 0.2V _{DD} -0.8V _{DD})	
Duty Cycle	(%)		45~55 (≤40MHz), 40~60(>40MHz) : at 1/2V _{DD}	
Fanout (gate)	C _L (pF)		15	
Stand-by Function			Yes (tri-state)	
Jitter	P-P (ps)		250 (max) : at C _L =15pF	

Note : If requested, Supply Voltage 2.7~3.3V (≤66.7MHz•Duty Cycle 40 ~ 60%), Operating Temp. Range -40~+85°C (Frequency Stability ±100×10⁻⁶) is available.

■ 1870XE • 1870YE Series Outline

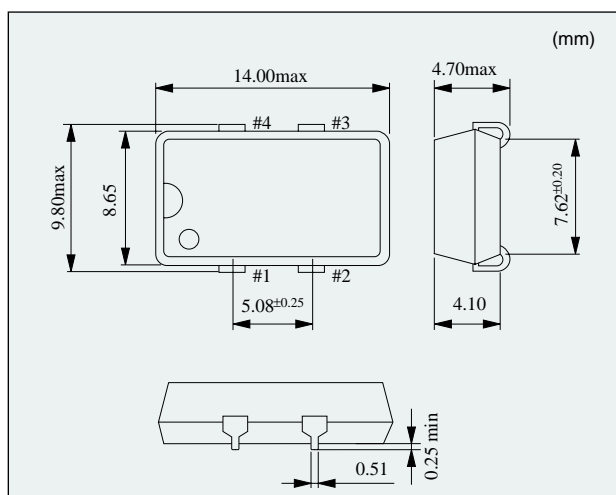

PIN	Connection
# 1	STAND-BY
# 2	GND
# 3	OUTPUT
# 4	+3.3VDC

■ Output Wave <C-MOS>

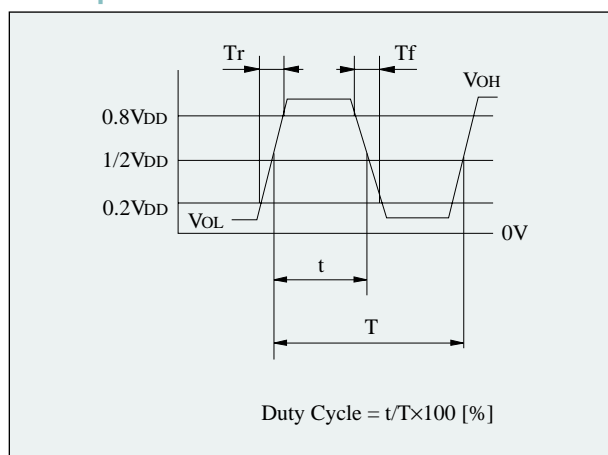

■ Stand-by Function

# 1 pin input	# 3 pin output
H level (0.7V _{DD} min) or open	Operating
L level (0.2V _{DD} max)	High impedance (Weak pull down)

1870VE • 1870WE SERIES

■ Features

- Directly drives C-MOS IC.
- The PLL technology enables this series to cover the frequency range from 1 to 125MHz.
- The frequency writing technology makes quick delivery possible.
- Stand-by function for output (Tri-state output).
- Compact and light weight : height 4.7mm, volume 0.4cm³, weight 1.5g.
- High reliability.
(metal hermetic sealed crystal unit is inhoused)
- Applicable for reflow automatic mounting processes.
- Static electricity proof packaging : tape & reel.

■ **Absolute Maximum Rating**
Supply Voltage (V_{DD}) -0.5~+7.0V DC
Storage Temperature Range -55~+125°C

Item	Model	1870VE	1870WE
Output Level		C-MOS	
Frequency Range	(MHz)	1~125	
Frequency Stability	($\times 10^{-6}$)	$\pm 50, \pm 100$	
Operating Temp. Range	(°C)	-20~+70	
Supply Voltage	(V)	5.0 \pm 10%	
Current Consumption (+5V, at 25°C)		45mA (max)	
	stand-by	30mA (max)	50 μ A (max)
V _{OL} max / V _{OH} min	(V)	0.4/V _{DD} -0.4 I _{OL} =8mA, I _{OH} =-8mA	
Tr max/Tf max	(ns)	3/3 (at 0.2V _{DD} -0.8V _{DD})	
Duty Cycle	(%)	45~55 (\leq 66.7MHz), 40~60(>66.7MHz): at 1/2V _{DD}	
Fanout (gate)	C _L (pF)	25	
Stand-by Function		Yes (tri-state)	
Jitter	P-P (ps)	250 max (<33MHz), 200 max (\geq 33MHz): at C _L =15pF	

Note : If requested, Operating Temp. Range -40~+85°C (Frequency 40MHz max./Frequency Stability $\pm 100 \times 10^{-6}$) is available.

■ 1870VE • 1870WE Series Outline

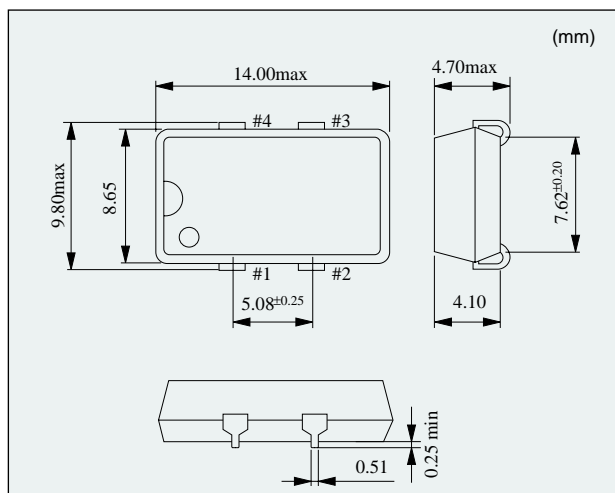

PIN	Connection
# 1	STAND-BY
# 2	GND
# 3	OUTPUT
# 4	+5VDC

■ Output Wave <C-MOS>

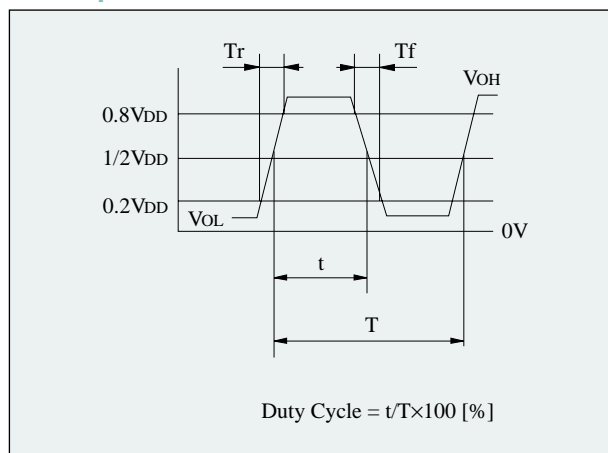

■ Stand-by Function

# 1 pin input	# 3 pin output
H level (+2.0 Vmin) or open	Operating
L level (+0.8 Vmax)	High impedance (Weak pull down)

CRYSTAL CLOCK OSCILLATORS

1880VE • 1880WE SERIES

■ Features

- Directly drives TTL IC.
- The PLL technology enables this series to cover the frequency range from 1 to 125MHz.
- The frequency writing technology makes quick delivery possible.
- Stand-by function for output.
- Compact and light weight : height 4.7mm, volume 0.4cm³, weight 1.5g.
- High reliability.
(metal hermetic sealed crystal unit is inhoused)
- Applicable for reflow automatic mounting processes.
- Static electricity proof packaging : tape & reel.

■ **Absolute Maximum Rating**
Supply Voltage (V_{DD}) -0.5~+7.0V DC
Storage Temperature Range -55~+125°C

Item	Model	1880VE	1880WE
Output Level		TTL	
Frequency Range	(MHz)	1~125	
Frequency Stability	(×10 ⁻⁶)	±50, ±100	
Operating Temp. Range	(°C)	-20~+70	
Supply Voltage	(V)	5.0±10%	
Current Consumption (+5V, at 25°C)		45mA (max)	
	stand-by	30mA (max)	50µA (max)
V _{OL} max / V _{OH} min	(V)	0.4/V _{DD} -0.4 I _{OL} =8mA, I _{OH} =-8mA	
Tr max/Tf max	(ns)	4/4 (at 0.4V _{DD} ~2.4V _{DD})	
Duty Cycle	(%)	45~55 (≤66.7MHz), 40~60(>66.7MHz): at 1.4V	
Fanout (gate)	TTL GATE	5	
Stand-by Function		Yes (tri-state)	
Jitter	P-P (ps)	250 max (<33MHz), 200 max (≥33MHz): at C _L =15pF	

Note : If requested, Operating Temp. Range -40~+85°C (Frequency 40MHz/Frequency Stability ±100×10⁻⁶) is available.

■ 1880VE • 1880WE Series Outline

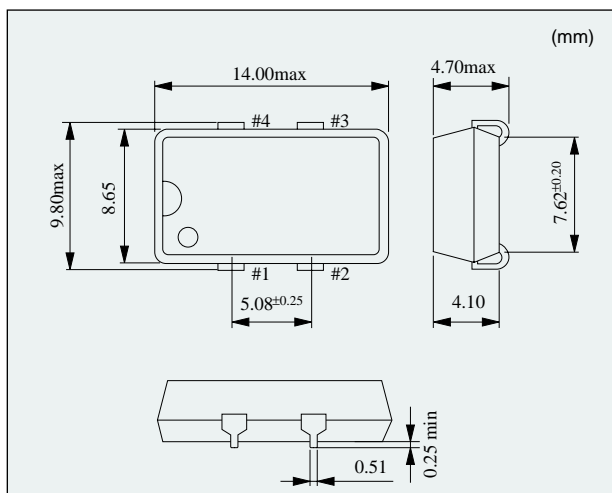

PIN	Connection
# 1	STAND-BY
# 2	GND
# 3	OUTPUT
# 4	+5VDC

■ Output Wave <TTL>

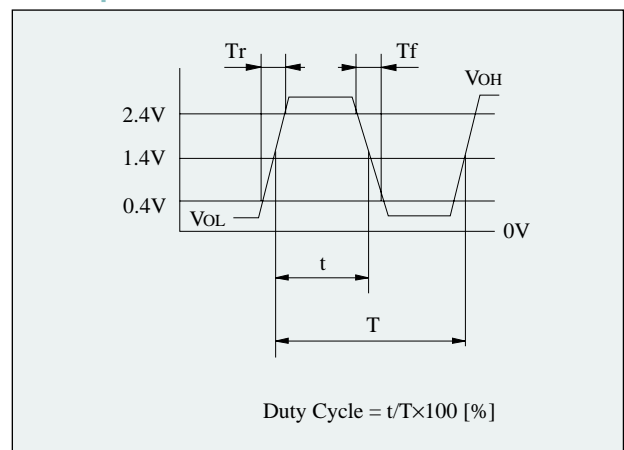

■ Stand-by Function

# 1 pin input	# 3 pin output
H level (+2.0 Vmin) or open	Operating
L level (+0.8 Vmax)	High impedance (Weak pull down)

Handling Cautions (1800 series)

Recommended footprint

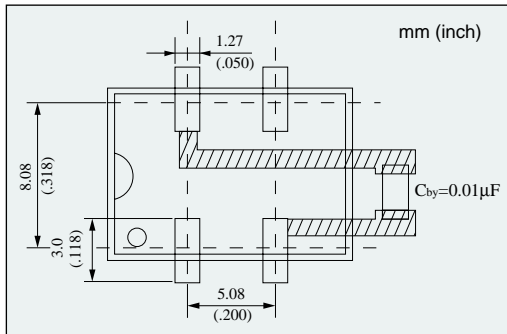

Examples for soldering conditions (Infra-red ray reflow soldering)

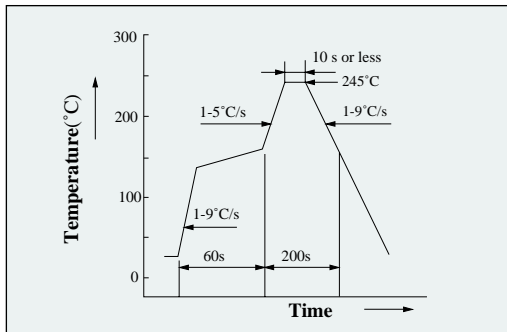

PLL cascade connection

Crystal units of this series output required frequencies by the PLL (Phase Locked Loop) circuit using quartz oscillation as a reference. Therefore, jitters may increase when the output of this oscillator is connected to a PLL in cascade where the oscillator is operated using an existing PLL circuit in the customer's system as a reference.

Check your system carefully before applying to image processing, synchronous process of communication, etc.

Output state during standby

Because the output of the clock oscillators of the 1800 series is pulled down to GND (weak pull-down) with a high impedance (typically 500 k Ω) during standby, the pull-down resistor for the input section of GATE IC of the next stage is not necessary. When pulling up the input section of the GATE IC of the next stage, a resistor of 10 k Ω to 50 k Ω or less should be used.

● Soldering

In order to avoid product damage during soldering, for reflow conditions, please follow either below conditions (a) or (b).

- (a) Temperature : 260°C (max)
Duration : 10 (max)
- (b) Temperature : 230°C (max)
Duration : 60 (max)

● Shock

Basically, the 1800 series include height resistance design against shock (guaranteed 3 times drops from 75 cm height on to hard wooden board).

In case of unexpected drop, please remeasure the product characteristics.

● Cleaning

Basically, the 1800 series are applicable for ultrasonic cleanings. However, in some cases, during ultrasonic cleanings, damage may occur. Please check conditions carefully beforehand.

● Others

The 1800 series are C-MOS products. And careful handling (same as with C-MOS IC) is needed to avoid electrostatic problems.

Incorrect pin connection is cause of trouble.

Please make sure to connect correctly as below.

- #2 terminal → GND
- #4 terminal → V_{DD}

Taping Dimensions (1800 Series)

■ Tape

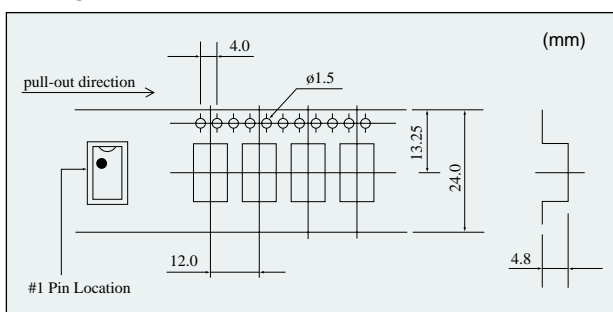

1,000 pieces/reel are boxed and shipped with the taping method as shown above

■ Reel

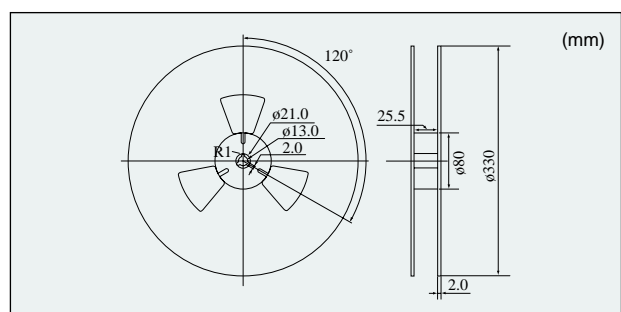

*Note The Packaging method shown above is only for large orders. For small orders, or for samples, the packaging form is different according to the requested quantity.