

DESCRIPTION

The RH1185AMK is a 3A low dropout regulator with adjustable current limit and remote sense capability. It can be used as a positive regulator with floating input or as a standard negative regulator with grounded input. The output voltage range is 2.5V to 25V, with $\pm 1\%$ accuracy on the internal reference voltage.

The RH1185AMK uses a saturation-limited NPN transistor as the pass element. This structure gives the linear dropout characteristics of a FET pass element with significantly less die area. High efficiency is maintained by using special anti-saturation circuitry that adjusts base drive to track load current.

The on-resistance is typically 0.25Ω . Accurate current limit is programmed with a single $1/8W$ external resistor, with a range of zero to three amperes. A second, fixed internal limit circuit prevents destructive currents if the programming current is accidentally overranged.

The RH1185AMK has all the protection features of previous LTC regulators, including power limiting and thermal shutdown.

ABSOLUTE MAXIMUM RATINGS

(Note 1)

Input Voltage.....	35V
Input-Output Differential	30V
FB Voltage.....	7V
REF Voltage.....	7V
Output Voltage	30V
Output Reverse Voltage.....	2V
Operating Ambient Temperature Range ..	-55°C to 125°C
Operating Junction Temperature Range	
Control Section	-55°C to 150°C
Power Transistor Section	-55°C to 175°C
Storage Temperature Range.....	-65°C to 150°C
Thermal Resistance Junction to Case	
TO-3 Control Area.....	1°C/W
Power Transistor	3°C/W
Lead Temperature (Soldering, 10 sec)	300°C

LT, LT, LTC, LTM, Linear Technology and the Linear logo are registered trademarks of Linear Technology Corporation. All other trademarks are the property of their respective owners.

BURN-IN CIRCUIT

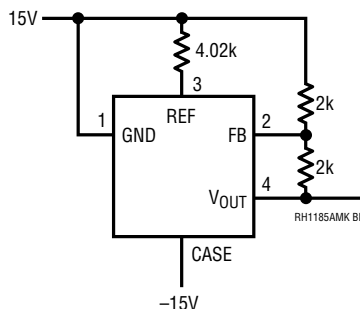

PACKAGE INFORMATION

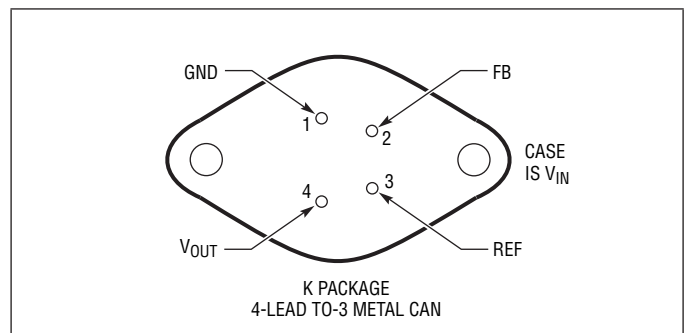

TABLE 1: ELECTRICAL CHARACTERISTICS(Preirradiation) $V_{IN} = 7.4V$, $V_{OUT} = 5V$, $I_{OUT} = 1mA$, $R_{LIM} = 4.02k$, unless otherwise noted.

PARAMETER AND CONDITIONS	$T_A = 25^\circ C$			SUB-GROUP	$-55^\circ C \leq T_A \leq 125^\circ C$			SUB-GROUP	UNITS
	MIN	TYP	MAX		MIN	TYP	MAX		
Reference Voltage (At FB Pin)		2.37				2.37			V
Reference Voltage Tolerance (At FB Pin) (Note 2) $V_{IN} - V_{OUT} = 5V$, $V_{OUT} = V_{REF}$	-1.0	0.3	1.0	1					%
Reference Voltage Tolerance $V_{IN} - V_{OUT} = 1.2V$ to $V_{IN} = 30V$, $1mA \leq I_{OUT} \leq 3A$, $P_D \leq 25W$ (Note 6), $V_{OUT} = 5V$, $T_{MIN} \leq T_J \leq T_{MAX}$ (Note 9)					-2.5		2.5	2, 3	%
Feedback Pin Bias Current, $V_{OUT} = V_{REF}$		0.7	2	1			2	2, 3	μA
Dropout Voltage (Note 3) $I_{OUT} = 0.5A$, $V_{OUT} = 5V$ $I_{OUT} = 3A$, $V_{OUT} = 5V$		0.2	0.37	1			0.55	2, 3	V
		0.67	1	1			1.4	2, 3	V
Load Regulation (Note 7) $I_{OUT} = 5mA$ to $3A$, $V_{IN} - V_{OUT} = 1.5V$ to $10V$, $V_{OUT} = 5V$		0.05	0.3	1			0.8	2, 3	%
Line Regulation (Note 7) $V_{IN} - V_{OUT} = 1V$ to $20V$, $V_{OUT} = 5V$		0.002	0.01	1			0.03	2, 3	%/V
Minimum Input Voltage (Note 4) $I_{OUT} = 1A$, $V_{OUT} = V_{REF}$ $I_{OUT} = 3A$, $V_{OUT} = V_{REF}$			3.9	1					V
			4.4	1					V
Internal Current Limit (See Graph for Guaranteed Curve) (Note 12) $1.5V \leq V_{IN} - V_{OUT} \leq 10V$ $V_{IN} - V_{OUT} = 15V$ $V_{IN} - V_{OUT} = 20V$ $V_{IN} - V_{OUT} = 30V$	3.3	3.6	4.2	1	3.1		4.4	2, 3	A
	2	3	4.2	1	2		4.3	2, 3	A
	1	1.7	2.6	1	1		3	2, 3	A
	0.2	0.4	1	1	0.2		1.1	2, 3	A
External Current Limit (Note 11) $R_{LIM} = 5k$, $V_{OUT} = 1V$ $R_{LIM} = 15k$, $V_{OUT} = 1V$	2.7	3	3.3	1	2.5		3.5	2, 3	A
	0.9	1	1.1	1	0.8		1.2	2, 3	A
Quiescent Supply Current (Note 5) $I_{OUT} = 5mA$, $V_{OUT} = V_{REF}$, $4V \leq V_{IN} \leq 25V$		2.5	3.5	1			3.5	2, 3	mA
Supply Current Change With Load $V_{IN} - V_{OUT} = V_{SAT}$ (Note 10) $V_{IN} - V_{OUT} \geq 2V$			25	1			40	2, 3	mA
			15	1			25	2, 3	mA
Thermal Regulation $V_{IN} - V_{OUT} = 10V$, $I_{OUT} = 5mA$ to $2A$							0.014		%/W
Reference Voltage Temperature Coefficient (Note 8)							0.01		%/°C

TABLE 1A: ELECTRICAL CHARACTERISTICS
 (Postirradiation)

PARAMETER AND CONDITIONS	10KRAD(Si)		20KRAD(Si)		50KRAD(Si)		100KRAD(Si)		200KRAD(Si)		UNITS
	MIN	MAX	MIN	MAX	MIN	MAX	MIN	MAX	MIN	MAX	
Reference Voltage Tolerance $V_{IN} - V_{OUT} = 5V, V_{OUT} = V_{REF}$	-1.2	1.2	-1.2	1.2	-1.5	1.5	-1.5	1.5	-2	2	%
Reference Voltage Tolerance $V_{IN} - V_{OUT} = 1.2V$ to $V_{IN} = 30V$, $1mA \leq I_{OUT} \leq 3A$, $P_D \leq 25W$ (Note 6), $V_{OUT} = 5V$, $T_{MIN} \leq T_J \leq T_{MAX}$ (Note 9)	-3	3	-3	3	-3.2	3.2	-3.5	3.5	-4	4	%
Feedback Pin Bias Current, $V_{OUT} = V_{REF}$	2		2		2.5		3		3		μA
Dropout Voltage (Note 3) $I_{OUT} = 0.5A, V_{OUT} = 5V$ $I_{OUT} = 3A, V_{OUT} = 5V$	0.4		0.4		0.4		0.425		0.45		V
	1		1		1		1.05		1.1		V
Load Regulation (Note 7) $I_{OUT} = 5mA$ to $3A$ $V_{IN} - V_{OUT} = 1.5V$ to $10V, V_{OUT} = 5V$	0.3		0.4		0.5		0.8		1		%
Line Regulation, Absolute Value (Note 7) $V_{IN} - V_{OUT} = 1V$ to $20V, V_{OUT} = 5V$	0.01		0.01		0.01		0.02		0.05		%/V
Minimum Input Voltage (Note 4) $I_{OUT} = 1A, V_{OUT} = V_{REF}$ $I_{OUT} = 3A, V_{OUT} = V_{REF}$	3.9		3.9		3.9		4		4		V
	4.4		4.4		4.4		4.5		4.5		V
Internal Current Limit (Note 12) $1.5V \leq V_{IN} - V_{OUT} \leq 10V$ $V_{IN} - V_{OUT} = 15V$ $V_{IN} - V_{OUT} = 20V$ $V_{IN} - V_{OUT} = 30V$	3.3	4.3	3.3	4.3	3.3	4.4	3.3	4.55	3.3	4.75	A
	2	4.3	2	4.3	2	4.35	2	4.5	2	4.7	A
	1	2.7	1	2.75	1	2.85	1	3.1	1	3.3	A
	0.2	1	0.2	1.15	0.2	1.3	0.2	1.6	0.2	2	A
External Current Limit (Note 11) $R_{LIM} = 5k$ $R_{LIM} = 15k$	2.7	3.3	2.7	3.4	2.7	3.5	2.7	3.7	2.7	3.9	A
	0.9	1.1	0.9	1.25	0.9	1.4	0.9	1.6	0.9	1.9	A
Quiescent Supply Current $I_{OUT} = 5mA, V_{OUT} = V_{REF}, 4V \leq V_{IN} \leq 25V$	3.5		3.5		3.5		3.5		3.5		mA
Supply Current Change With Load $V_{IN} - V_{OUT} = V_{SAT}$ $V_{IN} - V_{OUT} \geq 2V$	25		27		30		35		45		mA/A
	15		16		18		21		27		mA/A

Note 1: Stresses beyond those listed under Absolute Maximum Ratings may cause permanent damage to the device. Exposure to any Absolute Maximum Rating condition for extended periods may affect device reliability and lifetime.

Note 2: Reference voltage is guaranteed both at nominal conditions (no load, 25°C) and at worst-case conditions of load, line, power and temperature.

Note 3: Dropout voltage is tested by reducing input voltage until the output drops 1% below its nominal value. Tests are done at 0.5A and 3A. The power transistor looks basically like a pure resistance in this range so that minimum differential at any intermediate current can be calculated by interpolation; $V_{DROPOUT} = 0.25V + 0.25\Omega \cdot I_{OUT}$. For load current other than 0.5A and 3.0A, see graph in LT1185 data sheet.

Note 4: “Minimum input voltage” is limited by base emitter voltage drive of the power transistor section, not saturation as measured in Note 3. For output voltages below 4V, “minimum input voltage” specification may limit dropout voltage before transistor saturation limitation.

Note 5: Supply current is measured on the ground pin, and does not include load current, R_{LIM} , or output divider current.

Note 6: The 25W power level is guaranteed for an input-output voltage of 8.3V to 17V. At lower voltages the 3A limit applies, and at higher voltages the internal power limiting may restrict regulator power below 25W. See graph of Internal Current Limit in LT1185 data sheet.

Note 7: Line and load regulation are measured on a pulse basis with a pulse width of $\approx 2ms$, to minimize heating. DC regulation will be affected by thermal regulation and temperature coefficient of the reference. See the Applications Information section of LT1185 data sheet for details.

Note 8: Guaranteed by design and correlation to other tests, but not tested.

Note 9: $T_{JMIN} = -55^\circ C$ for the RH1185AMK. Power transistor area and control circuit area have different maximum junction temperatures. Control area limit is $T_{JMAX} = 150^\circ C$ for the RH1185AMK. Power area limit is $175^\circ C$ for RH1185AMK.

Note 10: V_{SAT} is the maximum specified dropout voltage; $0.25V + 0.25\Omega \cdot I_{OUT}$.

Note 11: Current limit is programmed with a resistor from REF pin to GND pin. The value is $15k \cdot A/I$ -limit.

Note 12: For $V_{IN} - V_{OUT} = 1.5V, V_{IN} = 5V$ and $V_{OUT} = 3.5V$. For all other current limit tests, $V_{OUT} = 1.0V$

TABLE 2: POST BURN-IN ENDPOINTS AND DELTA LIMITS REQUIREMENTS $T_A = 25^\circ\text{C}$

PARAMETER AND CONDITIONS	ENDPOINT LIMITS		DELTA LIMITS		UNITS
	MIN	MAX	MIN	MAX	
Reference Voltage, V_{REF} $V_{IN} = 7.4\text{V}, V_{OUT} = V_{REF}$	2.346	2.394	-0.040	0.040	V

TABLE 3: ELECTRICAL TEST REQUIREMENTS

MIL-STD-883 TEST REQUIREMENTS	SUBGROUP
Final Electrical Test Requirements (Method 5004)	1*, 2, 3
Group A Test Requirements (Method 5005)	1, 2, 3
Group B and D for Class S, End Point Electrical Parameters (Method 5005)	1, 2, 3

*PDA applies to subgroup 1. See PDA Test Notes.

PDA Test Notes

The PDA is specified as 5% based on failures from Group A, Subgroup 1, tests after cooldown as the final electrical test in accordance with method 5004 of MIL-STD-883. The verified failures of Group A, Subgroup 1, after burn-in divided by the total number of devices submitted for burn-in in that lot shall be used to determine the percent for the lot.

Linear Technology Corporation reserves the right to test to tighter limits than those given.

TOTAL DOSE BIAS CIRCUIT

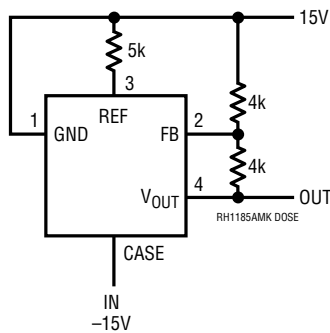

REVISION HISTORY

REV	DATE	DESCRIPTION	PAGE NUMBER
A	02/11	Changed title from RH1185MK to RH1185AMK. Revised Description. Removed REF Pin Shutoff Current from Tables 1 and Table 1A Electrical Characteristics. Removed REF Pin Shutoff Current Plot from the Typical Performance Characteristics section.	1-6 1 2, 3 6

TYPICAL PERFORMANCE CHARACTERISTICS

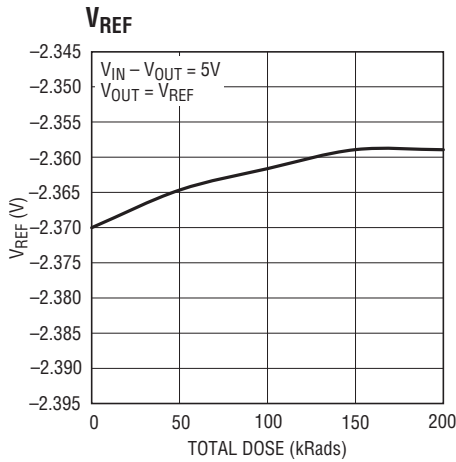

RH1185AMK G01

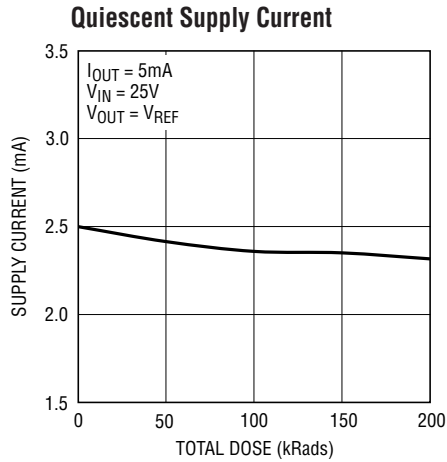

RH1185AMK G02

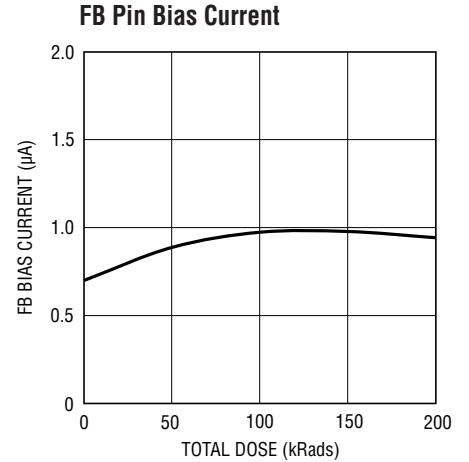

RH1185AMK G03

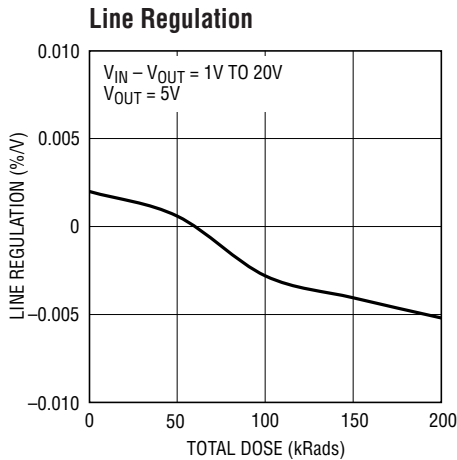

RH1185AMK G04

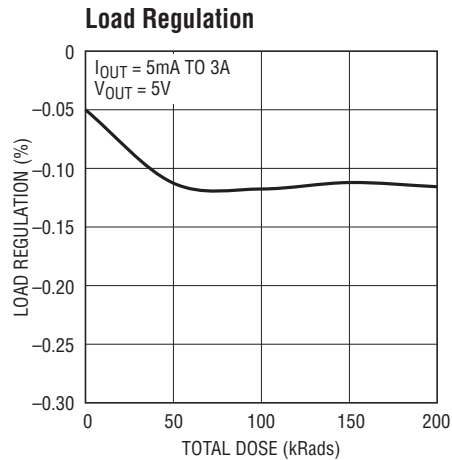

RH1185AMK G05

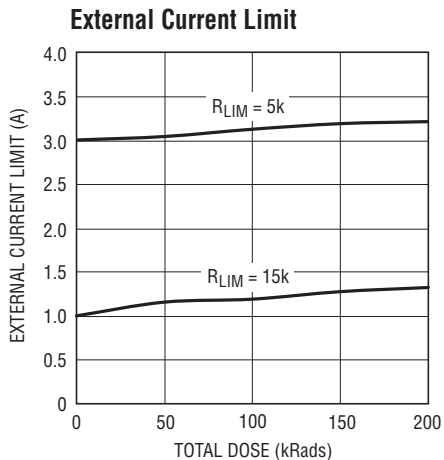

RH1185AMK G06

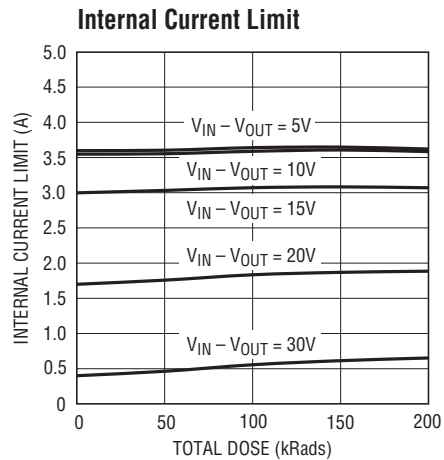

RH1185AMK G07