

DESCRIPTION

Three-channel laser diode pulse regulator iC-NZ enables the continuous wave operation of laser diodes and spike-free switching with defined current pulses in a frequency range of up to 155 MHz. The three channels can be accumulatively pulsed via inputs LENL, LENM and LENH. The peak optical power of the laser diodes is regulated separately for high, middle and low levels and adjusted using the three external resistors RMH, RMM and RML.

The iC is activated via pin EN which triggers a self-test of the device. The system is enabled if no errors are detected. Any errors are signaled at pin NERR.

The (average) current monitor can be set using external resistor RSI. Overcurrent is signalled at NERR, causing the iC to be shut down.

To ensure that the selected laser class is maintained a second monitor input SMD (*safety monitor diode*) is needed. This optional photo diode monitors the laser power. Exceeding the monitor window, set-up by RSMD, triggers a permanent reset. This is re-

ported at output NERR and can be deleted when the system is restarted at EN.

For high pulse frequencies the device can be switched into controlled *burst mode* at input REGEN. A previously settled operating point is maintained throughout the burst phase.

When the iC is switched on all safety-relevant signals pertinent to the current monitor, SMD and control unit are checked. These units are in turn monitored for the following: overcurrent, short circuits, open pins and whether the laser is switched off in terms of output power. With the exception of the latter these checks are carried out intermittently during operation. So that the device is single-failure-proof various safety check routines are also implemented. To this end a second SMD (*safety monitor diode*) monitoring the laser power is required. The laser power must stay within a defined range during operation (thus maintaining the laser class). If this range is left, the system is shut down and an error message is generated.

PACKAGES QFN28 5 mm x 5 mm to JEDEC Standard (MO-220-VHHD-1)

PIN CONFIGURATION QFN28 5 mm x 5 mm
(top view)

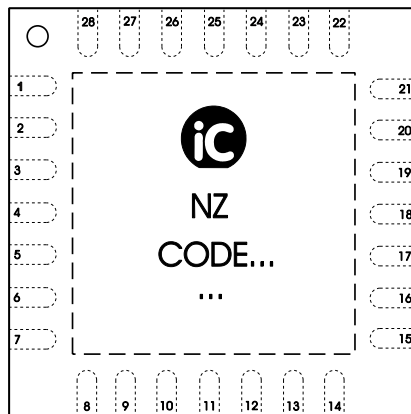

PIN FUNCTIONS

No.	Name	Function
1	RMDH	APC Setup, Monitor Input Hi
2	RVDD	Reference (P-type laser diodes)
3	RMDM	APC Setup, Monitor Input Mid
4	NSF	No-Safety Signal

PIN FUNCTIONS

No.	Name	Function
5	MDL	APC Setup, Monitor Input Lo
6	ENCAL	Enable Calibration
7	RGND	Internal Ground
8	SMD	Safety Monitor Diode
9	GND	Ground
10	VREF	Reference Voltage
11	CIL	Power Control Capacitor Lo
12	REGEN	Regulator Enable
13	CIM	Power Control Capacitor Mid
14	LENL	Enable Laser Channel Lo
15	LENM	Enable Laser Channel Mid
16	GND	Ground
17	LDKM	Cathode Laser Diode Mid
18	AGND	Analog Ground
19	LDKL	Cathode Laser Diode Lo
20	LDKH	Cathode Laser Diode Hi
21	LENH	Enable Laser Channel Hi
22	NERR	Error Output
23	EN	Enable Input
24	CIH	Power Control Capacitor Hi
25	LDA	Anode Laser Diode
26	RSI	Current Monitor Setup
27	SDIS	External Current Limitation
28	VDD	Power Supply

The *Thermal Pad* is to be connected to a Ground Plane (GND) on the PCB. Pins 9, 16 (GND) and 18 (AGND) must be connected externally, e.g. to a Ground Plane.

Orientation of package label (iC NZ CODE ...) may vary.

ABSOLUTE MAXIMUM RATINGS

Beyond these values damage may occur; device operation is not guaranteed.

Item No.	Symbol	Parameter	Conditions			Unit
				Min.	Max.	
G001	VDD	Supply Voltage VDD Current		-0.7	6	V
G002	I(VDD)	Current in VDD			400	mA
G003	I(CIx)	Current in Clx	V(LDA) = 0		5	mA
G004	I(NSF)	Current in NSF			20	mA
G005	I(SMD)	Current in SMD			20	mA
G006	I(NERR)	Current in NERR			20	mA
G007	I(MDL)	Current in MDL			20	mA
G008	I(RMDx)	Current in RMDx			20	mA
G009	I()dig	Current in LENL, LENM, LENH, REGEN, NEN, ENCAL			20	mA
G010	I(LDKx)	Current in LDKx			300	mA
G011	I(LDA)	Current in LDA			400	mA
G012	I(RSI)	Current in RSI			20	mA
G013	I(SDIS)	Current in SDIS			20	mA
G014	I(VREF)	Current in VREF			50	mA
G015	V()c	Voltage at RMDH, RVDD, RMDM, NSF, MDL, ENCAL, SMD, VREF, REGEN, Clx, LENx, NERR, LDA, RSI, SDIS		-0.7	6	V
G016	V()h	Voltage at LDKx		-0.7	15	V
G017	Vd()	ESD Susceptibility at all pins	HBM, 100 pF discharged through 1.5 kΩ		2	kV
G018	Tj	Operating Junction Temperature		-40	150	°C
G019	Ts	Storage Temperature Range		-40	150	°C

THERMAL DATA

Operating Conditions: VDD = 3.5...5.5 V

Item No.	Symbol	Parameter	Conditions				Unit
				Min.	Typ.	Max.	
T01	Ta	Operating Ambient Temperature Range (extended range on request)		-20		90	°C
T02	Rthja	Thermal Resistance Chip/Ambient	surface mounted, thermal pad soldered to ca. 2 cm ² heat sink		30	40	K/W

All voltages are referenced to ground unless otherwise stated.

All currents into the device pins are positive; all currents out of the device pins are negative.

ELECTRICAL CHARACTERISTICS

Operating Conditions: VDD = 3.5...5.5 V, Tj = -20...85 °C; x: L, M, H, unless otherwise stated

Item No.	Symbol	Parameter	Conditions	Min.	Typ.	Max.	Unit
Total Device							
001	VDD	Permissible Supply Voltage		3.5		5.5	V
002	I _{off} (VDD)	Supply Current in VDD	EN = lo		460	600	µA
003	I _{dc} (VDD)	Supply Current in VDD	EN = hi, RSI > 780 Ω		6.4	10	mA
004	Tab	Thermal Shutdown Threshold		110		150	°C
005	VDD _{en}	Power-On Threshold		2.1		2.95	V
006	V _c (hi)	Clamp Voltage hi at REGEN, LENH, LENM, LENL, EN, ENCAL, LDA, NERR, NSF	I() = 1 mA, other pins open, VDD = 0	0.3		1.5	V
007	V _c (hi)	Clamp Voltage hi at Clx, MDL, RMDH, RMDM SMD	I() = 1 mA, other pins open, VDD = 0	0.3		1.6	V
008	V _c (hi)	Clamp Voltage hi at LDKx	I() = 1 mA, other pins open	12			V
009	V _c (hi)	Clamp Voltage hi at RSI, VREF	I() = 1 mA, other pins open, VDD = 0	0.3	0.9	1.5	V
010	V _c (hi)	Clamp Voltage hi at SDIS	I() = 1 mA, other pins open	6			V
011	V _c (lo)	Clamp Voltage lo	I() = 1 mA, other pins open	-1.5	-0.65	-0.3	V
Reference							
101	V(MDL)	Voltage at MDL, VDD – V(MDL) for P-type LD	closed control loop	440	500	550	mV
102	dV(MDL)	Temperature Drift of Voltage at MDL	closed control loop		120		µV/°C
103	I()	Current in MDL, RMDM, RMDH	LENL, LENM, LENH = hi	-500		500	nA
104	V(VREF)	Voltage at VREF, VDD – VREF for P-type LD	iC active	405	480	550	mV
Digital Inputs							
201	I _{pd} ()	Pull-Down Current in LENx, EN	V(LDA) = V(VDD)	1	4	10	µA
202	I _{pd} (REGEN)	Pull-Down Current in REGEN	V(LDA) = V(VDD), V(ENCAL) < V _t ()	1	4	10	µA
203	V _t ()	Threshold Voltage at LENx, REGEN, ENCAL, EN	VDD = 5 V	0.75	1.8	2.2	V
204	V _{hys} ()	Hysteresis			800		mV
205	R _{pd} (REGEN)	Pull-Down Resistor at REGEN	V(ENCAL) > V _t ()	4		20	kΩ
206	R _{pd} (ENCAL)	Pull-Down Resistor at ENCAL		10		30	kΩ
Safety Monitor Diode							
301	VSL	Monitor Threshold lo, Signal SMD(0)		265	300	325	mV
302	VSH	Monitor Threshold hi, Signal SMD(1)		615	680	750	mV
303	dVS	VSH – VSL		350	390	430	mV
304	VCHK	Test Voltage for SMD				120	%VSH
305	I(RSMD)	Permissible Safety Monitor Diode Current				5	mA
306	I _{pd} (SMD)	Pull-Down-Current in SMD		0.2	0.6	3	µA
Laser Driver LDKx, CI, RMDx							
401	V _s (LDKx)	Saturation Voltage at LDKx	one channel only is activated; I(LDK) = 100 mA I(LDK) = 60 mA		1.2 0.8	2 1.3	V V
402	I _{dc} (LDKL)	Permissible Current	DC			120	mA
403	I _{dc} (LDKM)	Permissible Current	DC			100	mA
404	I _{dc} (LDKH)	Permissible Current	DC			100	mA
405	V _o ()	Permissible Voltage at LDKx				12	V
406	VCI()	REGOK Monitor Threshold		100	760	900	mV

ELECTRICAL CHARACTERISTICS

Operating Conditions: VDD = 3.5...5.5 V, Tj = -20...85 °C; x: L, M, H, unless otherwise stated

Item No.	Symbol	Parameter	Conditions				Unit
				Min.	Typ.	Max.	
407	C(Cl _x)	Capacitance at Cl _x		100			nF
408	I(Cl _x)	Charge Current from Cl _x	iC active, control unit not yet settled	0.25	0.6	1	mA
409	I(Cl _x)	Discharge Current in Cl _x	iC inactive, V(Cl _x) > 1 V	10		60	mA
410	I _{pd} (Cl _x)	Pull-Down Current in Cl _x	iC active, REGEN = lo	25		150	nA
411	I(RMD _x)	Permissible Laser Monitor Diode Current	active safety function; VDD = 5 V VDD = 3.3 V			2.5 1	mA mA
Status Outputs							
501	I(NERR)	Current at Error Message	V(LDA) = V(VDD) = V(NERR), error state	1.5		10	mA
502	I(NERR)	Current in NERR	V(LDA) = V(VDD) = V(NERR), no error state, V(MDL) < 0.5 V	0.1		1	mA
503	I(NSF)	Current at NSF Message	V(LDA) = V(VDD) = V(NSF), V(NSF) > 0.8 V	1.5		10	mA
504	I(SDIS)	Current at SDIS Message	V(LDA) = V(VDD) = V(SDIS), V(SDIS) > 0.8 V	1.0		10	mA
505	V _{sat} ()	Saturation Voltage at NERR, NSF, SDIS	I _{sat} = 1 mA, NERR in error state			600	mV
Current Monitor RSI, LDA							
601	V(RSI)	Controlled Voltage at RSI	EN = hi	430	490	560	mV
602	RSI	Resistor at RSI		0.78		9	kΩ
603	VLDA	LDAOK Monitor Threshold VDD - V(LDA)		440	490	550	mV
604	I _{dc} (LDA)	Current from LDA	DC			320	mA
605	R _{pd} (LDA)	Pull-Down Resistor at LDA	Reset			1	kΩ
606	t _d (SDIS)	Overcurrent Shutdown Delay	I(LDA) > I(RSI) * 500			10	μs
607	r _I LDA	Current Ratio I(LDA) _{max} / I(RSI)	780 Ω < RSI < 9000 Ω	400	500	650	
608	I _{pd} (RSI)	Pull-Down Current in RSI	V(RSI) > 0.5 V	1		10	μA
Timing							
701	t _{en}	Propagation Time: EN lo → hi system enable	no error at self test, CLDA = 1 μF			300	μs
702	t _r	Laser Current Rise Time	see Fig. 2			1.5	ns
703	t _f	Laser Current Fall Time	see Fig. 2			1.5	ns
704	t _{plh}	Propagation Time: LEN _x lo → hi to Current lo → hi	see Fig. 3			10	ns
705	t _{p_hl}	Propagation Time: LEN _x hi → lo to Current hi → lo	see Fig. 3			10	ns
706	t _{s0}	Propagation Time: V(SMD) > VSL to SMD(0) lo → hi	see Fig. 4 Tj = 27 °C Tj = 85 °C			220 240	ns ns
707	t _{s0_{off}}	Propagation Time: V(SMD) < VSL to SMD(0) hi → lo				220	ns
708	t _{s1}	Propagation Time: V(SMD) > VSH to SMD(1) lo → hi	see Fig. 4			220	ns
709	t _{off}	Propagation Time: SMD(1) lo → hi until shutdown	see Fig. 4			10	ns
710	t _d	Propagation Time: SMD(1) lo → hi until error message	see Fig. 4			500	ns

ELECTRICAL CHARACTERISTICS: DIAGRAMS

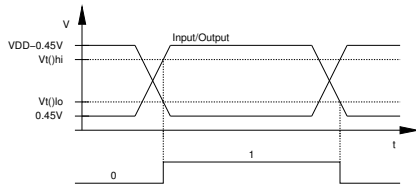

Figure 1: Reference levels

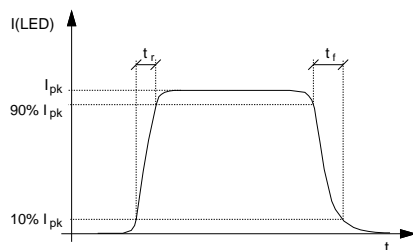

Figure 2: Laser current pulse

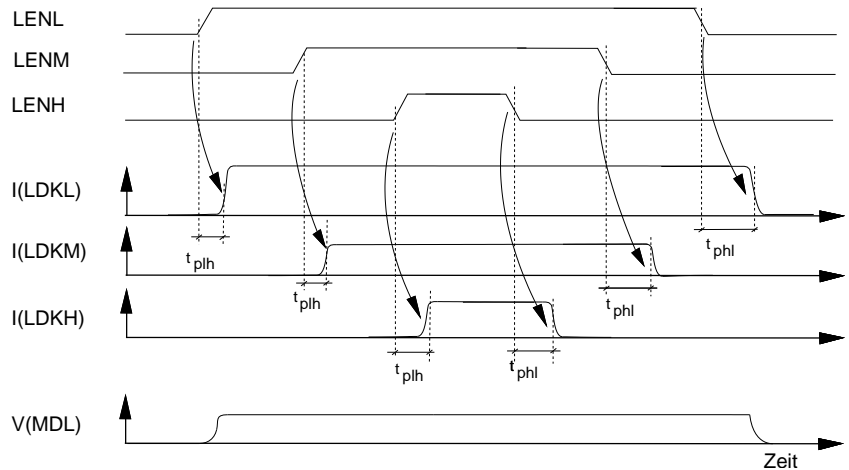

Figure 3: Turn on/turn off behavior of the laser current

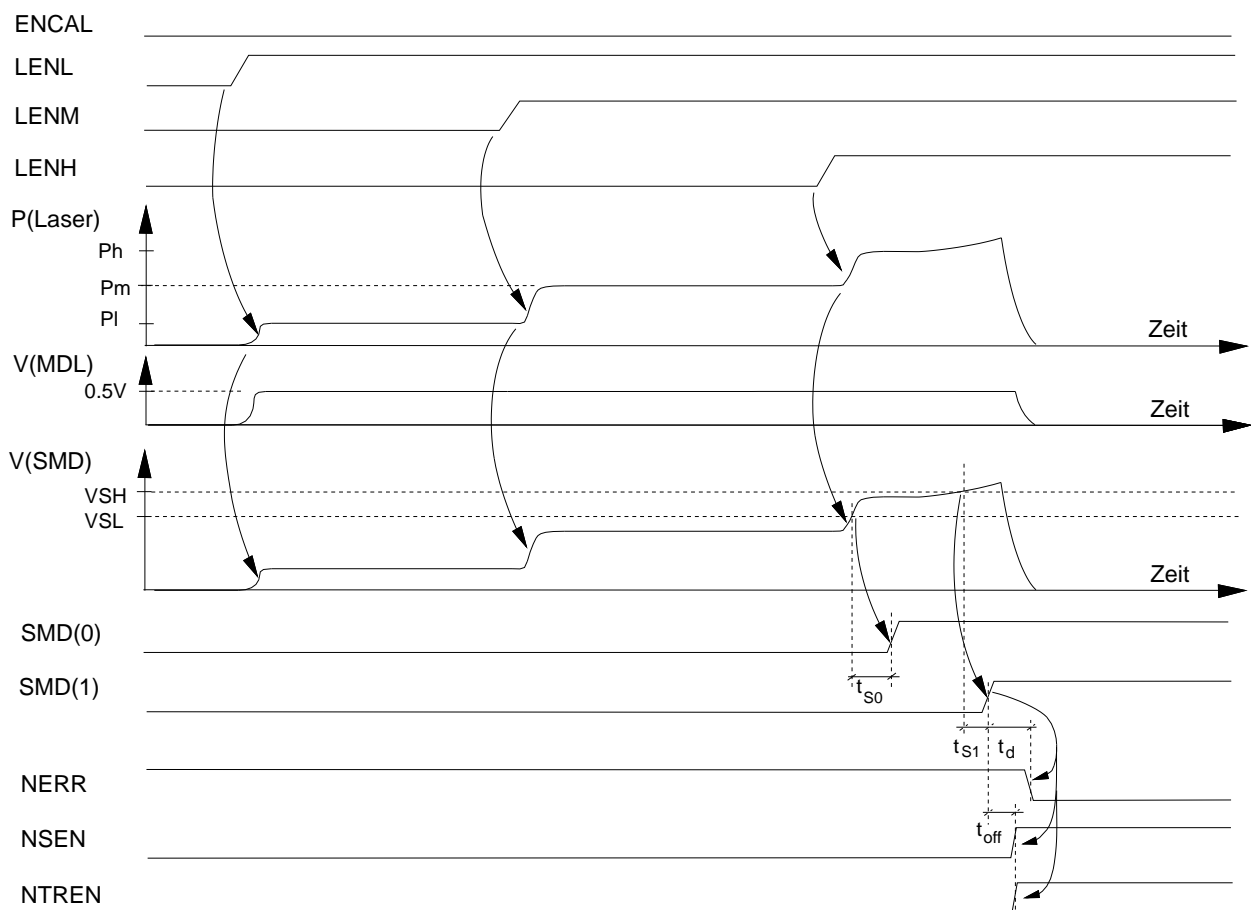

Figure 4: Safety shutdown times with failure of the control unit, for example

CONTENTS

DESCRIPTION OF FUNCTIONS	9	Warning!	12
Monitoring the laser current	9	OPERATION WITH ONE OR TWO CHANNELS	12
Demo board	9	SINGLE-FAILURE PROTECTION	15
Switching up to three laser power levels	9	Calibrating the safety monitor diode	15
1. Enabling the system	10	Demo-Board	15
Demo board	10	Operation without a second monitor diode	15
Possible sources of error	10	Demo-Board	15
2. Calibrating the low and middle channels	10	MISCELLANEOUS	17
Setting the low output level	10	Status outputs NERR, NSF and REGEN	17
Demo board	10	Controlled burst mode	17
Setting the middle channel	10	Extending the laser current	17
Demo board	11	Driving blue laser diodes	19
3. Calibrating the high channel	11	DEMO BOARD	19
Demo board	11		
Possible sources of error	11		
Demo-Board	12		

DESCRIPTION OF FUNCTIONS

iC-NZ is a three-channel laser diode pulse regulator which is single-failure-proof and able to maintain a selected laser class. The device includes the following functions:

- Monitoring of the laser current
- Switching of three laser light intensity levels which are regulated separately
- Single-failure-proof via laser light monitoring using a second monitor diode and shut-down of the laser in the event of error via three separate, independent switches
- External error messaging
- Pulses of up to 155 MHz in controlled *burst mode*, during which a previously set operating point is maintained

- Extension of the laser current with few external components
- Operation of blue laser diodes possible

To simplify the initial operation of iC-NZ the following passage first outlines the basic steps involved and then goes on to provide details referring to the demo board available for evaluation. A HL6339G HITACHI laser diode has been used here by way of example.

Monitoring the laser current

iC-NZ monitors the laser current flowing from pin LDA (Figure 5). The DC current threshold is set using a resistor at pin RSI. If this threshold is exceeded, the device is shut down for safety reasons.

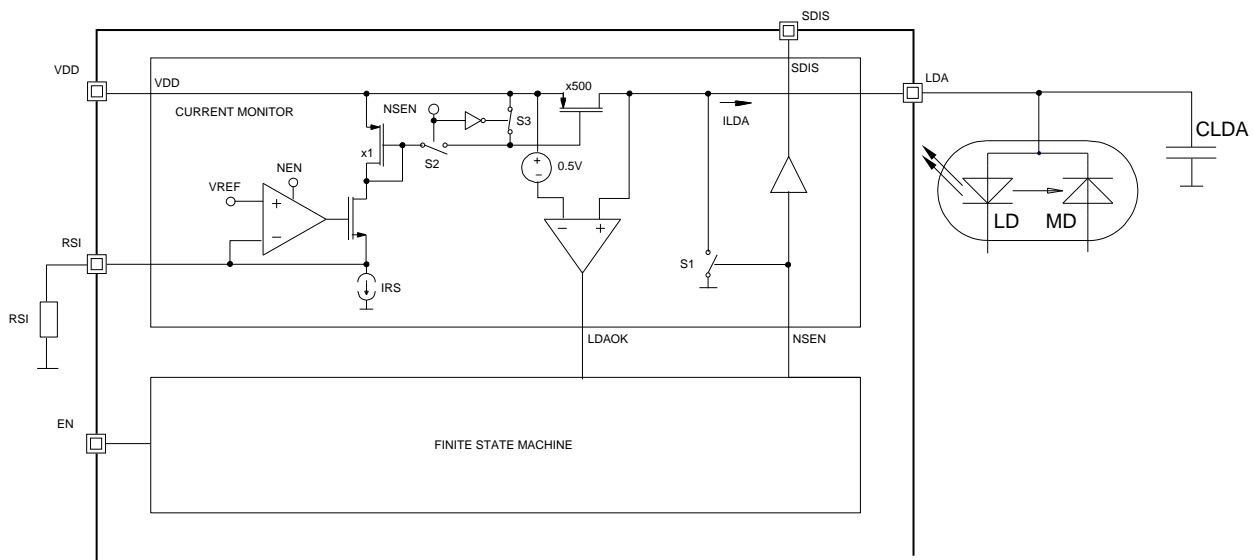

Figure 5: Monitoring the laser current

When dimensioning resistor RSI the following applies:

$$I_{max}(LDA) = 500 \times \frac{0.5 V}{RSI}$$

current RSI is calculated as:

$$RSI = 500 \times \frac{0.5 V}{70 mA} = 3.5 k\Omega$$

Short pulses with higher currents are also possible as the DC current is monitored. Capacitor CLDA supplies the current for short, higher pulses.

Demo board

According to the manufacturer's specifications laser diode HL6339G requires a maximum current of 70 mA for an optical power of 5 mW. For this maximum 70 mA

Switching up to three laser power levels

The following steps must be taken to set the required optical power:

1. Enabling the system
2. Calibrating the low and middle channels
3. Calibrating the high channel

1. Enabling the system

Before iC-NZ is put into operation for the first time the external circuitry should be checked for the following (see block diagram):

- Resistor RSMD should be of low impedance. It may not, however, be lower than $250\ \Omega$, otherwise the internal iC check will generate an error message.
- The resistors at pins RMDL, RMDM and RMDH should be of high impedance (low output).
- Inputs LENL, LENM and LENH should be switched to low (the driver stages switched off).

So that iC-NZ can be switched on pin EN must be set to high and pin ENCAL to low. A current in the milliampere range (Electrical Characteristics No. 501) now flows into pin NERR. This indicates that the device is now in its start-up phase. The voltage at pin RSI is set to $0.5\ \text{V}$ and capacitor CLDA charged at pin LDA. Once voltage $V(\text{LDA})$ has reached its final value the control unit and safety monitor diode are checked, if the latter is in use (see also *Operation without a second monitor diode*). Following this check the current into pin NERR is lowered (Electrical Characteristics No. 502). The residual current still remaining (ca. $500\ \mu\text{A}$) indicates that the control unit is not yet in operation (N-type: $V(\text{MDL}) < 0.5\ \text{V}$, P-type: $V(\text{DD}) - V(\text{MDL}) < 0.5\ \text{V}$). The entire process is described in Figure 6.

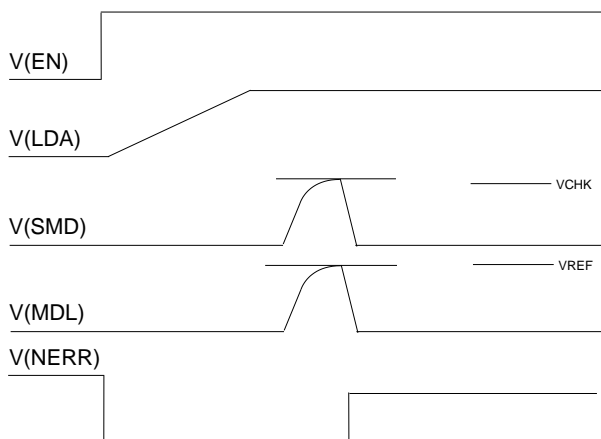

Figure 6: Signal pattern when the system is enabled

Demo board

Before the demo board is put into operation trimmers PSMDL, PML, PMM and PMH should be set to the left and trimmer PSMDH to its centre setting.

Possible sources of error

- $V(\text{NERR})$ remains at low:
 - Check the current in NERR. Is the impedance of the pull-up resistor too high?
- Too high a current is flowing through pin NERR: An error has occurred during the device self-test. Check the following:
 - Is ENCAL lo?
 - Is RSMD of too low an impedance? RSMD may not be lower than $250\ \Omega$.
 - Is pin SMD open or has it directly short-circuited with VCC?
 - Is there a direct connection between pin LDK and ground?
 - Is there a low-impedance connection between pin LDA and ground?
 - Have all Clx capacitors (x: L, M, H) been properly soldered and placed close to the iC?
 - Is VCC properly back upped?

2. Calibrating the low and middle channels

So that the optical power can be regulated pin REGEN must be set to high. The level at pin ENCAL is of no consequence when setting the low and middle channels.

Setting the low output level

Pin LENL is first switched from low to high. The integration capacitor at CIL is then charged. Until the control unit has settled a small amount of current flows in pin NERR. Following this the voltage at pin MDL is $0.5\ \text{V}$ for an N-type diode and $V(\text{DD}) - 0.5\ \text{V}$ for a P-type diode. The required optical power can now be set at resistor RML.

Demo board

By way of example, three output levels of $1\ \text{mW}$, $3\ \text{mW}$ and $5\ \text{mW}$ are to be set. With an optical power of $1\ \text{mW}$ laser diode HL6339G has a typical monitor current (I_M) of $15\ \mu\text{A}$. The following value is then obtained for the resistor at pin MDL ($RML_n = PML + RML$):

$$RML_n = \frac{V(\text{MDL})}{I_M} = \frac{0.5\ \text{V}}{15\ \mu\text{A}} = 33.34\ \text{k}\Omega$$

Setting the middle channel

Pin LENL must remain at high and LENM be switched from low to high. Following the settling of the control unit at CIM (N-type: $V(\text{MDL}) < 0.5\ \text{V}$; P-type: $V(\text{DD}) - V(\text{MDL}) < 0.5\ \text{V}$) the required optical power can be set at resistor RMM.

Demo board

With an optical power of 3 mW the monitor current (I_M) is 43 μ A. This current must flow through the parallel connection of RML_n and RMM_n ($RMM_n = PMM + RMM$). The following then applies:

$$RML_n || RMM_n = \frac{V(MDL)}{I_M} = \frac{0.5 V}{43 \mu A} = 11.62 k\Omega$$

$$RMM_n = \frac{RML_n || RMM_n * RML_n}{RML_n - RML_n || RMM_n}$$

$$RMM_n = \frac{11.62 k\Omega * 33.34 k\Omega}{33.34 k\Omega - 11.62 k\Omega} = 17.84 k\Omega$$

3. Calibrating the high channel

Here, pins REGEN and ENCAL must be high. This deactivates the monitoring of the optical power, thus enabling the calibration of the high output level. Pins

LENL and LENM must remain at high; pin LENH must also be switched from low to high. Following the settling of the control unit at CIH the required optical power can be set at resistor RMH.

Demo board

With an optical power of 5 mW laser diode HL6339G has a typical monitor current (I_M) of 80 μ A. The following value is then obtained for resistor $RMH_n = PMH + RMH$:

$$RML_n || RMM_n || RMH_n = \frac{V(MDL)}{I_M} = \frac{0.5 V}{80 \mu A} = 6.25 k\Omega$$

$$RMH_n = \frac{RML_n || RMM_n || RMH_n * RML_n || RMM_n}{RML_n || RMM_n - RML_n || RMM_n || RMH_n}$$

$$RMH_n = \frac{6.25 k\Omega * 11.62 k\Omega}{11.62 k\Omega - 6.25 k\Omega} = 13.52 k\Omega$$

Possible sources of error

- V(NERR) remains at low:
 - Check the current in NERR. Is the impedance of the pull-up resistor too high?
- Too high a current is flowing at pin NERR (ERROR state):
 - Is the laser diode properly connected and the control unit functioning correctly?
 - Are RMDL, RMDM or RMDH of too low an impedance? (Possible shut-down due to overcurrent!)
 - Are all the capacitors at C1x (x: L, M, H) large enough and have they been properly soldered?
 - Is pin AGND connected to ground?
- No laser light:
 - Is pin AGND connected to ground?
 - Is there a short circuit between C1x and ground?
 - Is the laser diode (type N or P) properly connected and the control unit functioning correctly?
 - The laser diode lights up for a few seconds and then turns off:
 - * Is the laser diode too hot? With insufficient cooling the laser diode power consumption increases which can trigger an overcurrent shut-down.

Demo-Board

When using an N-type laser diode jumper J2 must be placed between pins 2 and 3 on the demo board. If a P-type laser diode is used the jumper must be connected between pins 1 and 2.

Warning!

Following calibration pin EN has to be briefly set to low before actual operation may start with EN set to high again. The following explains why.

When the low channel (LENL → hi) is switched on capacitor CIL is charged. When the middle channel is switched in the internal control unit switches to CIM and starts to charge it. The voltage at CIL is then no longer regulated. As residual current could boost the voltage at CIL, which in turn would increase the current in the low channel, thus the capacitor at CIL is actively discharged with a maximum of 100 nA. The current in the low channel slowly decreases. As the control unit endeavours to keep the optical power constant, the capacitor at CIM is charged at the same rate as CIL is gradually discharged. If the middle channel is now switched off, the control unit switches back to the low channel. Capacitor CIL is regulated again; CIM, however, remains charged. If the middle channel

were then again to be switched on, far too much current would flow; this could destroy the laser diode. The same happens if the low and middle channels are regulated and the high channel switched on for a lengthy period of time. In this instance CIL and CIM are slowly discharged and the voltage at CIH rises in order to maintain a constant optical power. The entire process is illustrated in Figure 7.

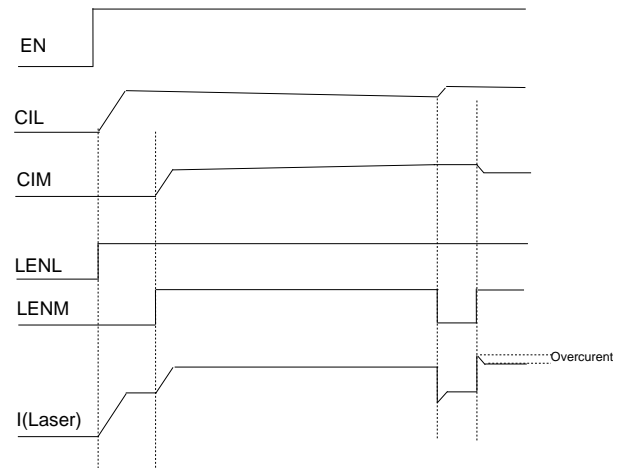

Figure 7: Behavior with very long power-on times

OPERATION WITH ONE OR TWO CHANNELS

It is of course also possible to operate iC-NZ with one or two levels of light intensity. To make use of the safety functions of the system in one- or two-channel mode, pins LDKx (x: L, M) on the unused channels must be kept unconnected. Nodes Cix should be directly short-

circuited with AGND. To use the safety functions of the safety monitor diode the high channel must always be in use in one- or two-channel mode. Figures 8 to 11 give the configuration of iC-NZ for one- or two-channel operation for both N- and P-type laser diodes.

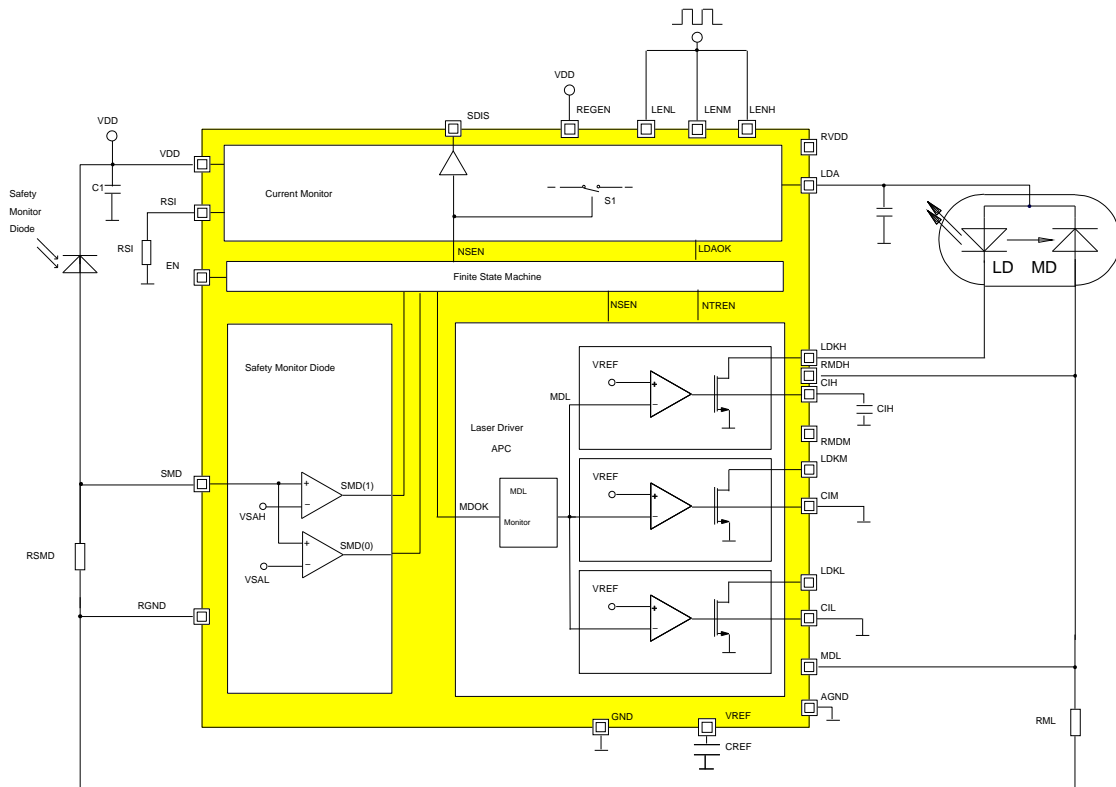

Figure 8: One-channel operation with safety function (N-type laser diode)

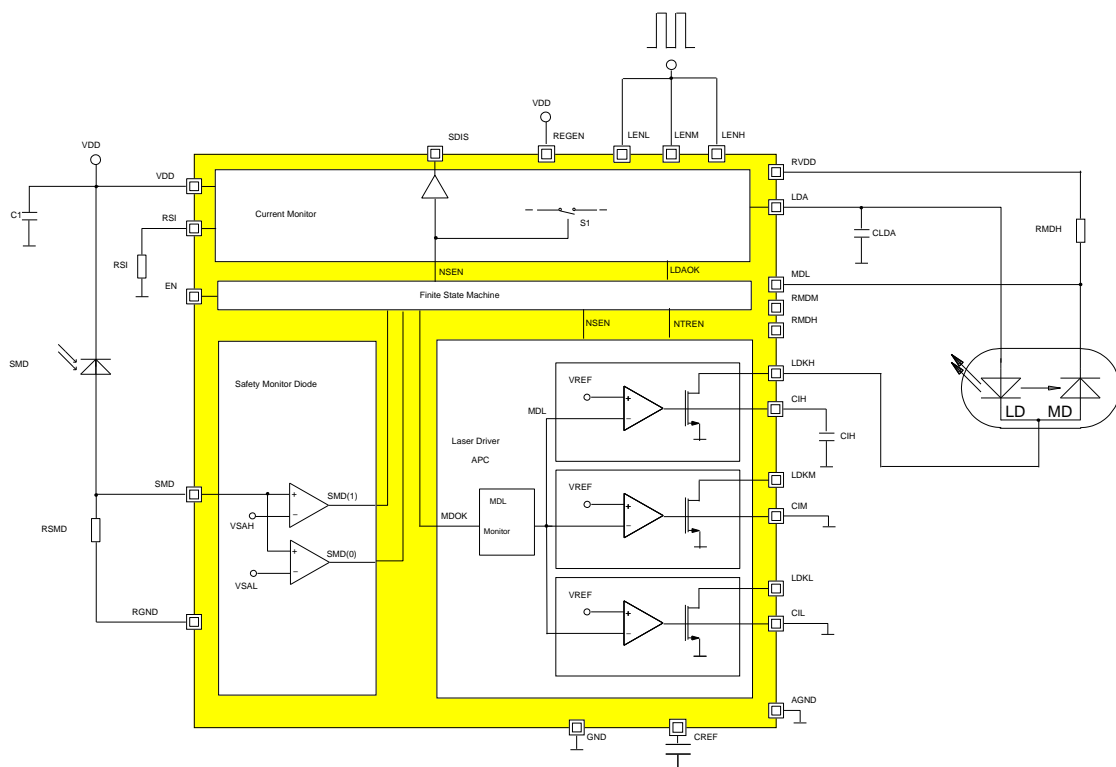

Figure 9: One-channel operation with safety function (P-type laser diode)

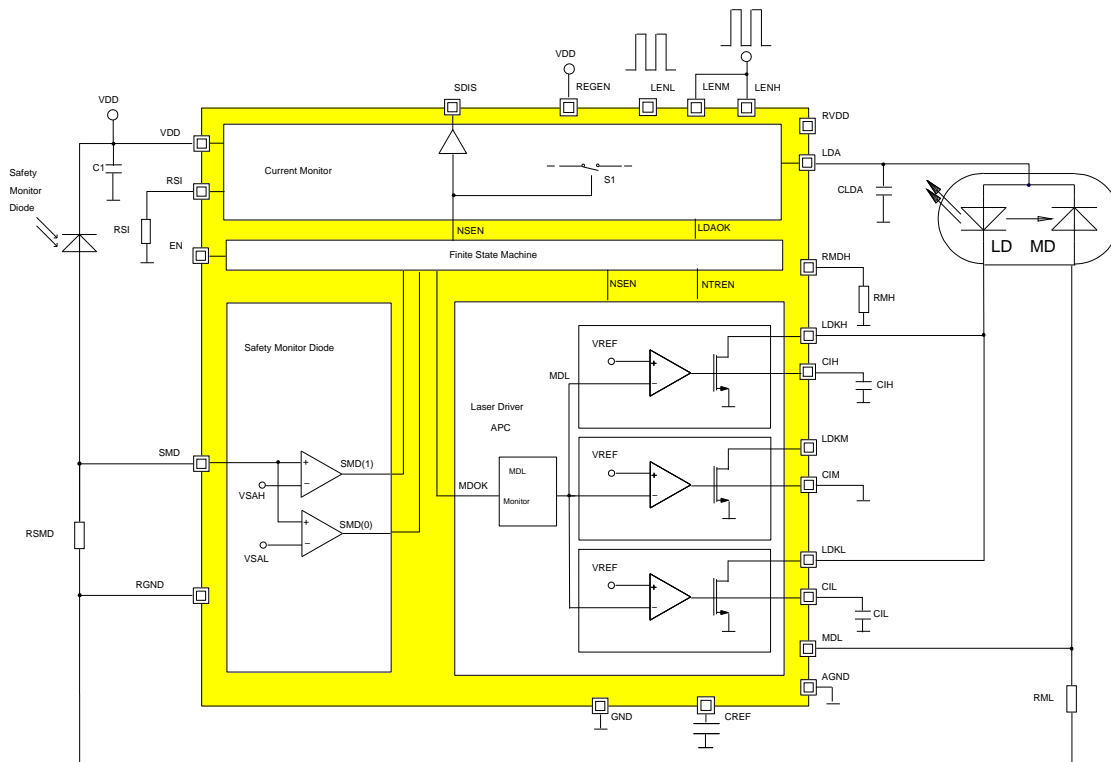

Figure 10: Two-channel operation with safety function (N-type laser diode)

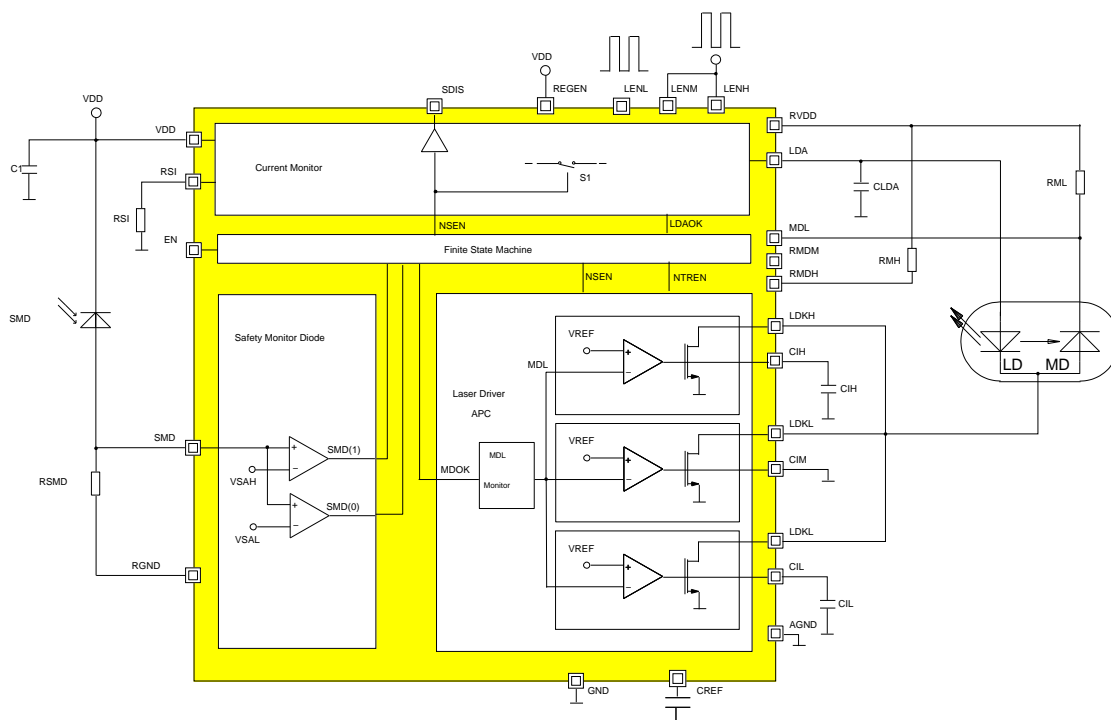

Figure 11: Two-channel operation with safety function (P-type laser diode)

SINGLE-FAILURE PROTECTION

Maintaining the laser class and the single-failure protection feature are achieved by means of a second monitor diode and by monitoring the laser current. Further safety is provided by the layout of the laser driver stages. The output stages consist of several identical driver cells where each cell can discharge the integration capacitor C_{Ix} (x: L, M, H) and shut down the laser current. So that the laser can be switched off in the event of error iC-NZ has three completely separate circuits. The second diode monitors whether the laser light is within a predetermined power range or not.

Calibrating the safety monitor diode

To calibrate the safety monitor diode iC-NZ is first activated via EN (low → high) with ENCAL at low. Once the device self-test has been successfully carried out (NERR is high) pin ENCAL must be set to high and the system switched to maximum optical power (pins LENL, LENM and LENH switched to high). Resistor

RSMD at pin SMD is now set so that voltage $V(SMD)$ is inside the monitor window between 0.3 V and 0.7 V. ENCAL can now be switched back to low.

In applications with a low duty cycle both the peak and average laser power must be monitored to maintain the laser class. To this end the resistor at RSMD is split into RSMD1 and RSMD2 and a capacitor (CSMD) connected in parallel to RSMD1 (see Figure 12). With short laser light pulses capacitor CSMD behaves as if it is a short circuit and bypasses RSMD1. In this instance only RSMD2 is active (higher shutdown threshold). With longer pulses resistors RSMD1 and RSMD2 are in series (lower shutdown threshold). This setup dynamically alters the monitor window. An excess of the maximum permissible laser power through both too high a pulse power or too long a pulse duration is equally detected.

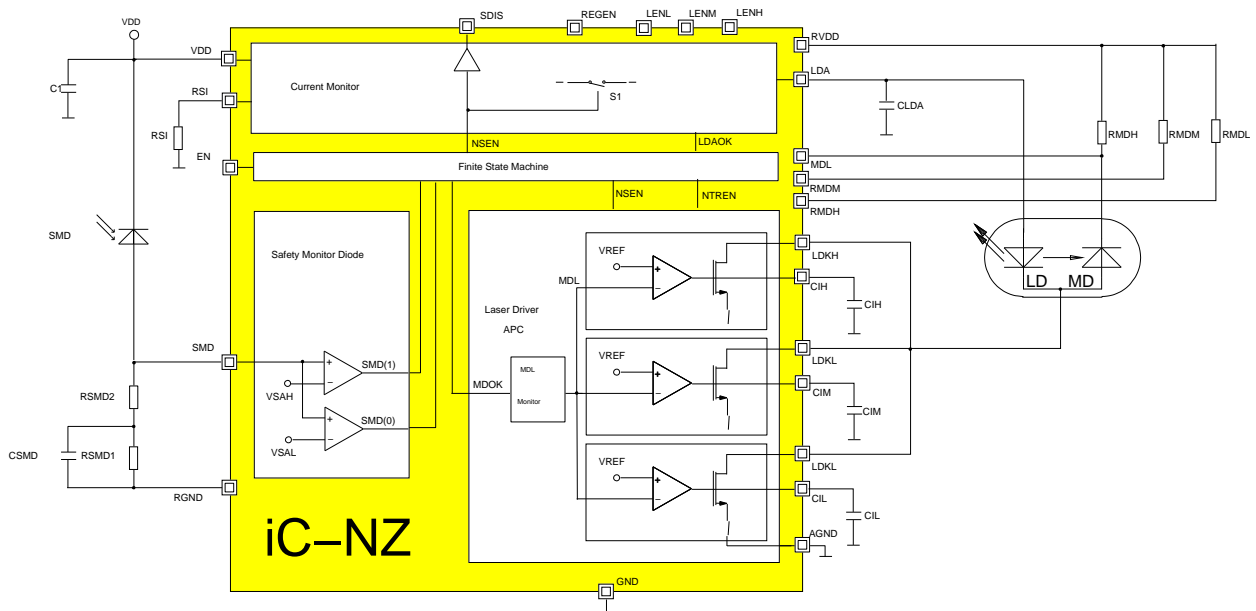

Figure 12: Dynamic adaptation of the monitor window

Demo-Board

So that the second monitor diode can be used jumper J1 must be placed between pins 1 and 2 on the demo board. The voltage at SMD is set using the two potentiometers PSMDH (peak) and PSMDL (average).

Operation without a second monitor diode

The monitoring function can be disabled for applications which do not require a second monitor diode. To this end pins SMD and ENCAL must be set to high. This *no safety function* (NSF) is signalled at pin NSF.

The overcurrent monitor at LDA is, however, still active in this mode. This ensures safe operation with so called *low-power applications* – even without a second monitor diode. Figures 13 and 14 give the circuitry for N- and P-type laser diodes.

Demo-Board

So that the demo board can be operated without a second monitor diode, jumper J1 must be placed between pins 2 and 3.

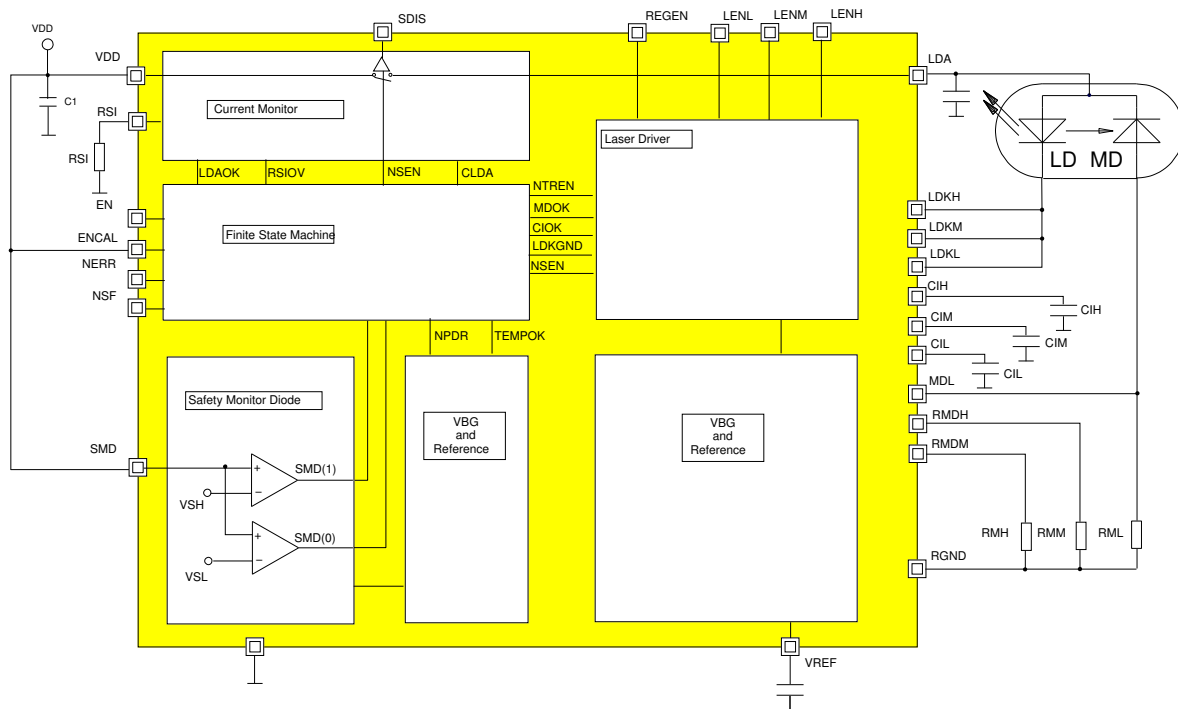

Figure 13: Operation without a second monitor diode (N-type laser diode)

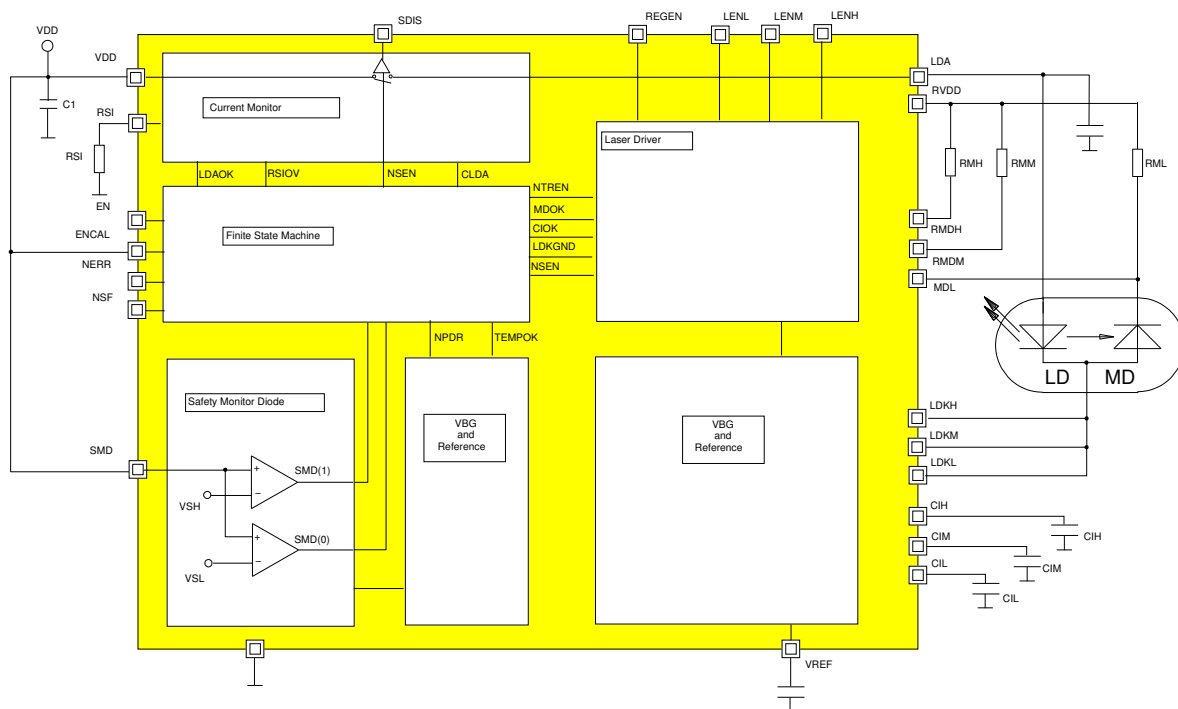

Figure 14: Operation without a second monitor diode (P-type laser diode)

MISCELLANEOUS

Status outputs NERR, NSF and REGEN

Pin **NERR** is an open-collector output with three states:

$I(\text{NERR}) = 0 \text{ mA}$	Pin EN is low or the control unit is operational (no error)
	N-type laser diode: $V(\text{MDL}) = 0.5 \text{ V}$
	P-type laser diode: $V(\text{MDL}) = V\text{DD} - 0.5 \text{ V}$
$I(\text{NERR}) > 1.5 \text{ mA}$	Error or iC-NZ is still undergoing its self-test
$0 < I(\text{NERR}) < 1.5 \text{ mA}$	No error, the control unit is not yet settled or not enough laser light
	N-type laser diode: $V(\text{MDL}) < 0.5 \text{ V}$
	P-type laser diode: $V(\text{MDL}) < V\text{DD} - 0.5 \text{ V}$

Pin **NSF** is also an open-collector output and signals the *no safety mode*:

$I(\text{NSF}) > 1.5 \text{ mA}$	iC-NZ is in <i>safety mode</i>	operation with a second monitor diode
$I(\text{NSF}) = 0 \text{ mA}$	iC-NZ is in <i>no safety mode</i>	operation without a second monitor diode

Pin **REGEN**, in addition to its mode select input function (regulated output power \leftrightarrow *burst mode*), also signals the condition of Pin ENCAL by its pull-down current:

$I_{\text{pd}}(\text{REGEN}) < 10 \mu\text{A}$	ENCAL = low	cf. Item No. 202
$I_{\text{pd}}(\text{REGEN}) > 100 \mu\text{A}$	ENCAL = high	cf. Item No. 205

Controlled burst mode

In controlled *burst mode* iC-NZ can pulse with up to 155 MHz, thus making it suitable for use in laser projection or data transmission. *Controlled* here means that a preset operating point is maintained during fast pulsing or the *burst phase*.

A low power level is first regulated, for which REGEN and LENL must be high. Following this the middle or high power level can be set (LENx \rightarrow high). The control unit then switches over to the middle or high channel. As only one channel can be regulated at any one time and as the voltage at CIL must not increase by residual current (this could destroy the laser diode) the capacitor at CIL is discharged with a maximum of 100 nA. Once Cix has been regulated LENx can return to low. REGEN at low switches into *burst mode* and thus turns the control unit off. The preset operating point is maintained. To prevent the laser current rising due to residual current the capacitors for the three channels are discharged with a maximum of 100 nA. This process is illustrated in Figure 15. As the capacitors are discharged gradually the output levels must be regulated again after a certain period. With an integration capacitance (Cix) of 100 nF, for example, the level must

again be regulated after 500 μs , with this rising to 1 ms with 200 nF.

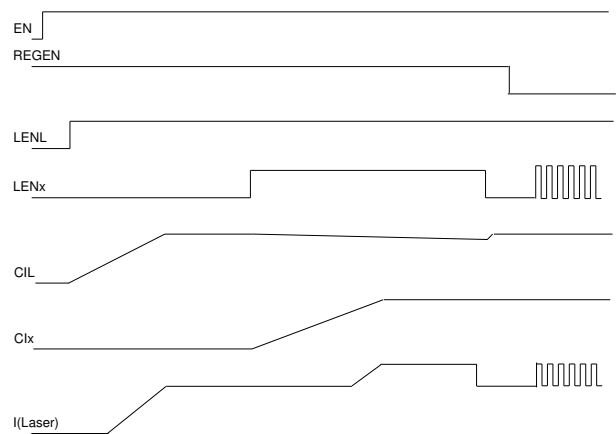

Figure 15: Controlled burst mode

Extending the laser current

iC-NZ also has a high-current mode. Here, the laser current no longer flows through the iC but passes instead through the external circuitry (RLDA, Q1, iC-HK); pin RSI is switched to VDD. The current monitor is still active and the shutdown threshold can be set us-

Driving blue laser diodes

It is also possible to drive blue laser diodes with iC-NZ. The laser diode is then directly powered by a second, higher voltage. The laser power is set as described above in *Switching up to three laser power lev-*

e/s. Figure 17 shows iC-NZ connected up to a blue laser diode. It is important to note that here the laser diode supply voltage should be as low as possible to keep iC power dissipation to a minimum.

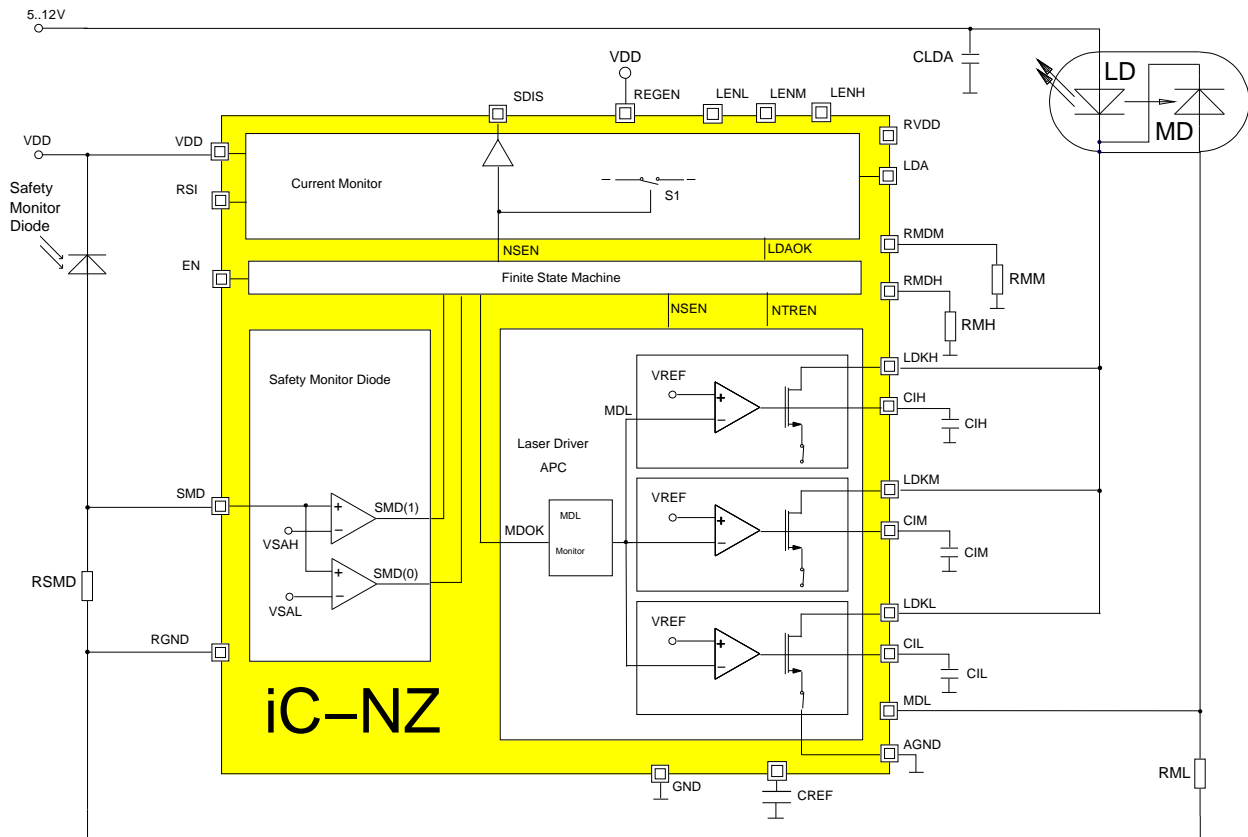

Figure 17: Driving blue laser diodes

DEMO BOARD

The iC-NZ device is equipped with a Demo Board for test purposes. A description of the demo board is available as a separate document.

This specification is for a newly developed product. iC-Haus therefore reserves the right to change or update, without notice, any information contained herein, design and specification; and to discontinue or limit production or distribution of any product versions. Please contact iC-Haus to ascertain the current data. Copying – even as an excerpt – is only permitted with iC-Haus approval in writing and precise reference to source. iC-Haus does not warrant the accuracy, completeness or timeliness of the specification on this site and does not assume liability for any errors or omissions in the materials. The data specified is intended solely for the purpose of product description. No representations or warranties, either express or implied, of merchantability, fitness for a particular purpose or of any other nature are made hereunder with respect to information/specification or the products to which information refers and no guarantee with respect to compliance to the intended use is given. In particular, this also applies to the stated possible applications or areas of applications of the product. iC-Haus conveys no patent, copyright, mask work right or other trade mark right to this product. iC-Haus assumes no liability for any patent and/or other trade mark rights of a third party resulting from processing or handling of the product and/or any other use of the product.

ORDERING INFORMATION

Type	Package	Order Designation
iC-NZ	QFN28 5 mm x 5 mm	iC-NZ QFN28
Evaluation Board		iC-NZ EVAL NZ1D

For technical support, information about prices and terms of delivery please contact:

iC-Haus GmbH
Am Kuemmerling 18
D-55294 Bodenheim
GERMANY

Tel.: +49 (61 35) 92 92-0
Fax: +49 (61 35) 92 92-192
Web: <http://www.ichaus.com>
E-Mail: sales@ichaus.com

Appointed local distributors: http://www.ichaus.de/support_distributors.php