

**891-003 and -004**  
**Series 89 Nanominiature Connectors**  
**Double Row Uninsulated Wire Pigtail Assemblies**

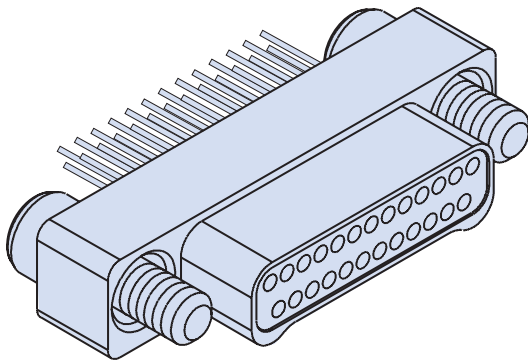

Double Row Connectors



**Glennair's Pigtail Nano Connectors** feature gold alloy TwistPin contacts. Contacts are precision-crimped to solid wire. These nanominiature connectors offer premium performance and reliability for demanding applications. Contact spacing is .025 inches. 1 amp current rating, DWV rating 300 volts AC. Wire gages #30 and #32 AWG.

**TwistPin Contact System** assures premium performance in demanding environments. The gold/platinum alloy contacts will stand up to years of exposure without corrosion.

**Typical Applications** include UAV's, satellites, missile systems and geophysical instruments.

**HOW TO ORDER NANOMINIATURE CONNECTORS WITH UNINSULATED WIRE**

Series	Insert Arrangement/ Contact Type	Shell Material and Finish	Wire Gage	Wire Type	Wire Length	Hardware
<b>891-003</b> Plug, Pin Contacts, Double Row, Nanominiature, Uninsulated Wire	Plugs (891-003)	<b>A1</b> Aluminum Shell, Cadmium Plating	<b>0</b> #30 AWG	<b>D3</b> Single Strand Copper Wire, Uninsulated, with Gold Plating	<b>.125</b> <b>.250</b> <b>.375</b> <b>.500</b> Wire Length in Inches	<b>J</b> Jackscrew, #0-80  <b>T</b> #0-80 Female Thread  Female Threads are available on plug connectors only if the shell material is titanium or stainless steel.
	<b>9P</b>					
	<b>15P</b>					
	<b>21P</b>					
	<b>25P</b>					
	<b>31P</b>					
<b>891-004</b> Receptacle, Socket Contacts, Double Row, Nanominiature, Uninsulated Wire	Receptacles (891-004)	<b>A2</b> Aluminum Shell, Electroless Nickel Plating	<b>2</b> #32 AWG	<b>T</b> Titanium Shell, Unplated		
	<b>9S</b>					
	<b>15S</b>					
	<b>21S</b>					
	<b>25S</b>					
	<b>31S</b>					
	<b>37S</b>					
	<b>51S</b>					
	<b>S</b> Stainless Steel Shell, Passivated					

**Sample Part Number**

<b>891-003</b>	<b>— 9P</b>	<b>A1</b>	<b>—0</b>	<b>D3</b>	<b>— 12</b>	<b>J</b>
----------------	-------------	-----------	-----------	-----------	-------------	----------

**PLUG (PIN) CONNECTOR**

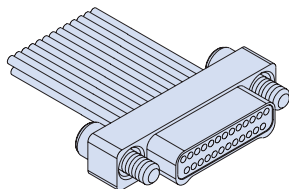

"J" Jackscrew Option

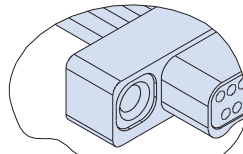

"T" Female Thread Option  
Titanium or Stainless Steel Shells Only

**RECEPTACLE (SOCKET) CONNECTOR**

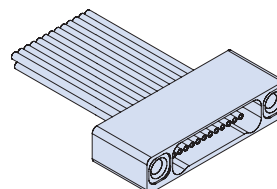

"T" Female Thread Option

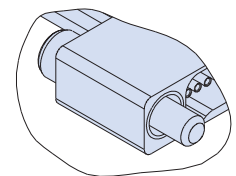

"J" Jackscrew Option

DOUBLE ROW NANO PIGTAIL DIMENSIONS

Plug (Pin) Connectors

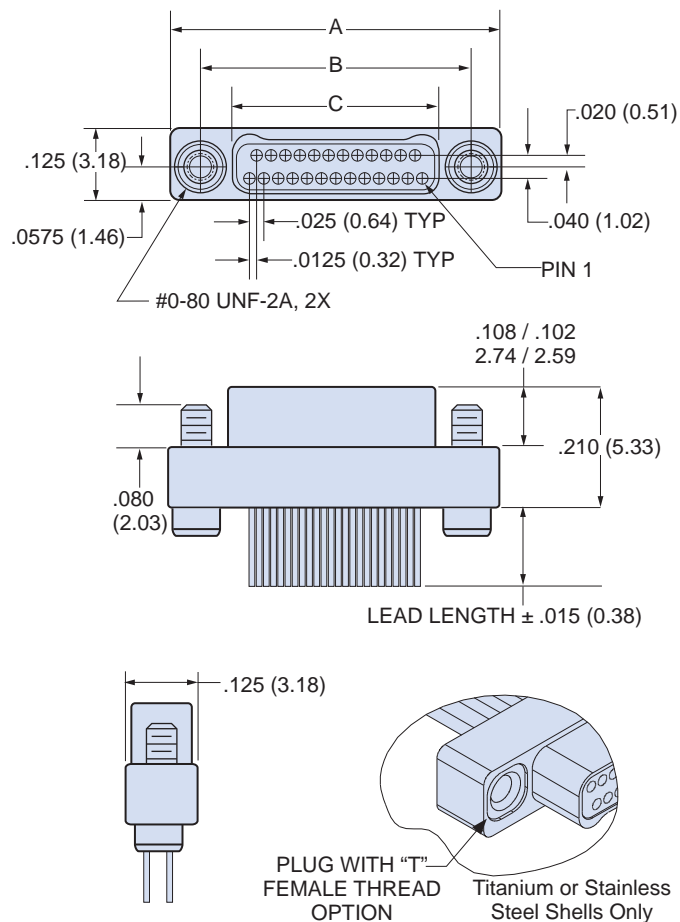

Receptacle (Socket) Connectors

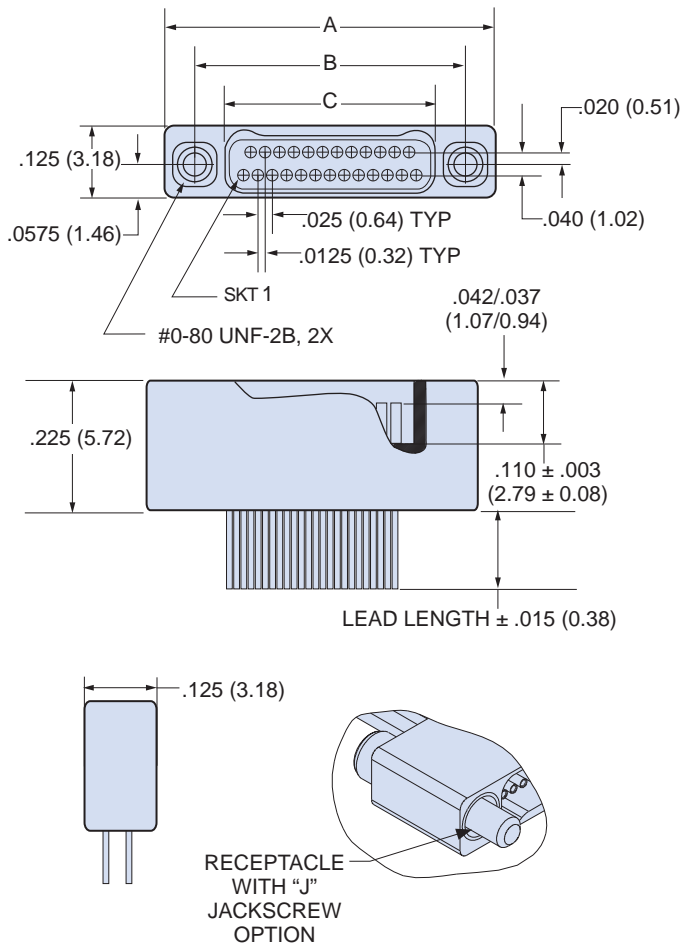

Layout	A		B BSC.		C BSC.	
	In. ± .005	mm. ± 0.13	In.	mm.	In.	mm.
9P	.375	9.52	.270	6.86	.160	4.06
9S	.375	9.52	.270	6.86	.163	4.14
15P	.450	11.43	.345	8.76	.235	5.97
15S	.450	11.43	.345	8.76	.238	6.04
21P	.525	13.33	.420	10.67	.310	7.87
21S	.525	13.33	.420	10.67	.313	7.95
25P	.575	14.60	.470	11.94	.360	9.14
25S	.575	14.60	.470	11.94	.363	9.22
31P	.650	16.51	.545	13.84	.435	11.05
31S	.650	16.51	.545	13.84	.438	11.12
37P	.725	18.41	.620	15.75	.510	12.95
37S	.725	18.41	.620	15.75	.513	13.03
51P	.900	22.86	.795	20.19	.685	17.40
51S	.900	22.86	.795	20.19	.688	17.47