

APPLICATION NOTES

- To be identified with manufacturer's name, part number and date code, space permitting.
- Material/Finish:
 - Shell* and Jam-Nut:
 - Z1 - Stainless steel/passivated.
 - FT - Carbon steel/tin plated.
 - ZL - Stainless steel/nickel plated.
 - Contacts - 52 Nickel alloy/gold plated.
 - Bayonets - Stainless steel/passivated.
 - Seals - Silicone elastomer/N.A.
 - Insulation - Glass/N.A.
- Glenair 230-028 will mate with any QPL MIL-DTL-83723/86, /91, /95 and /97 Series III bayonet coupling plug of same size, keyway, and insert polarization.
- Performance:
 - Hermeticity 1×10^{-7} cc He/sec @ 1 atmosphere differential.
 - Dielectric withstanding voltage - Consult factory or MIL-STD-1554.
 - Insulation resistance - 5000 MegOhms min @ 500VDC.
- Consult factory and/or MIL-STD-1554 for arrangement, keyway, and insert position options.
- Metric Dimensions (mm) are indicated in parentheses.

* Additional shell materials available, including titanium and Inconel®. Consult factory for ordering information.

230-028

MIL-DTL-83723/88 Series III Type Hermetic Threaded Coupling Square Flange Mount Receptacle with Solder Cup Terminations



MIL-DTL
83723

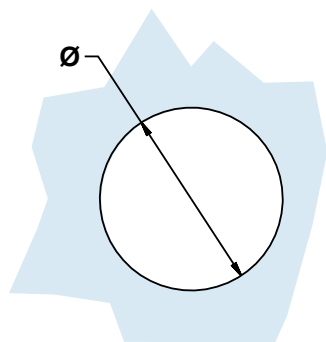

Panel Cut Out

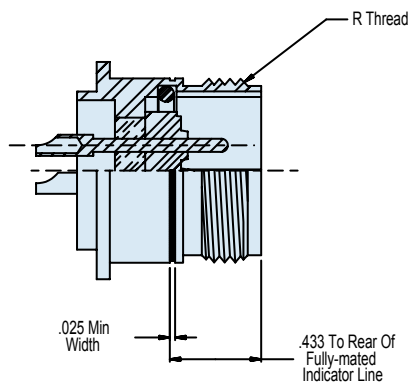

HERMETIC LEAK RATE MOD CODES

Designator	Required Leak Rate
-585A	1 x 10 ⁻¹⁰ cc's Helium per second
-585B	1 x 10 ⁻⁹ cc's Helium per second
-585C	1 x 10 ⁻⁸ cc's Helium per second

TABLE I: CONNECTOR AND CUT-OUT DIMENSIONS

Shell Size	A	B	C Dia	D Dia Shell I.D.	E Dia Resilient Insert	F Dia Max Seal	G Dia Max	H Dia Thru 4 PI	CC Dia Min	R Coupling Thread UNEF-2A	Panel Cut-Out
8	.812 (20.6)	.594 (15.1)	.500/.494 (12.7/12.5)	.418/.413 (10.6/10.5)	.290 (7.4)	.394 (10.0)	.562 (14.3)	.125/.116 (3.2/2.9)	.400 (10.2)	.562-24	.572 (14.5)
10	.937 (23.8)	.719 (18.3)	.562/.556 (14.3/14.1)	.535/.530 (13.6/13.5)	.388 (9.9)	.515 (13.1)	.696 (17.7)	.125/.116 (3.2/2.9)	.411 (10.4)	.688-24	.706 (17.9)
12	1.031 (26.2)	.812 (20.6)	.750/.744 (19.1/18.9)	.705/.700 (17.9/17.8)	.558 (14.2)	.685 (17.4)	.875 (22.2)	.125/.116 (3.2/2.9)	.581 (14.8)	.875-20	.885 (22.5)
14	1.125 (28.6)	.906 (23.0)	.812/.806 (20.6/20.5)	.774/.796 (19.7/20.2)	.627 (15.9)	.754 (19.2)	.935 (23.7)	.125/.116 (3.2/2.9)	.650 (16.5)	.938-20	.946 (24.0)
16	1.250 (31.8)	.969 (24.6)	.937/.931 (23.8/23.6)	.901/.896 (22.9/22.8)	.772 (19.6)	.881 (22.4)	1.062 (27.0)	.125/.116 (3.2/2.9)	.777 (19.8)	1.062-18	1.072 (27.2)
18	1.343 (34.1)	1.062 (27.0)	1.062/1.056 (27.0/26.8)	1.007/1.002 (25.6/25.5)	.860 (21.8)	.987 (25.1)	1.187 (30.1)	.125/.116 (3.2/2.9)	.864 (21.9)	1.188-18	1.197 (30.4)
20	1.437 (36.5)	1.156 (29.4)	1.187/1.181 (30.1/30.0)	1.132/1.125 (28.8/28.6)	.985 (25.0)	1.112 (28.2)	1.312 (33.3)	.125/.116 (3.2/2.9)	1.034 (26.3)	1.312-18	1.322 (33.6)
22	1.562 (39.7)	1.250 (31.8)	1.312/1.306 (33.3/33.2)	1.257/1.252 (31.9/31.8)	1.110 (28.2)	1.237 (31.4)	1.437 (36.5)	.125/.116 (3.2/2.9)	1.133 (28.8)	1.438-18	1.447 (36.8)
24	1.703 (43.3)	1.375 (34.9)	1.437/1.431 (36.5/36.3)	1.382/1.377 (35.1/35.0)	1.235 (31.4)	1.362 (34.6)	1.562 (39.7)	.154/.145 (3.9/3.7)	1.284 (32.6)	1.562-18	1.572 (39.9)

E