

## Silicon NPN Power Transistors

BU2527AF

## DESCRIPTION

- With TO-3PFa package
- High voltage
- High speed switching

## APPLICATIONS

- For use in horizontal deflection circuits of high resolution monitors

## PINNING

PIN	DESCRIPTION
1	Base
2	Collector
3	Emitter

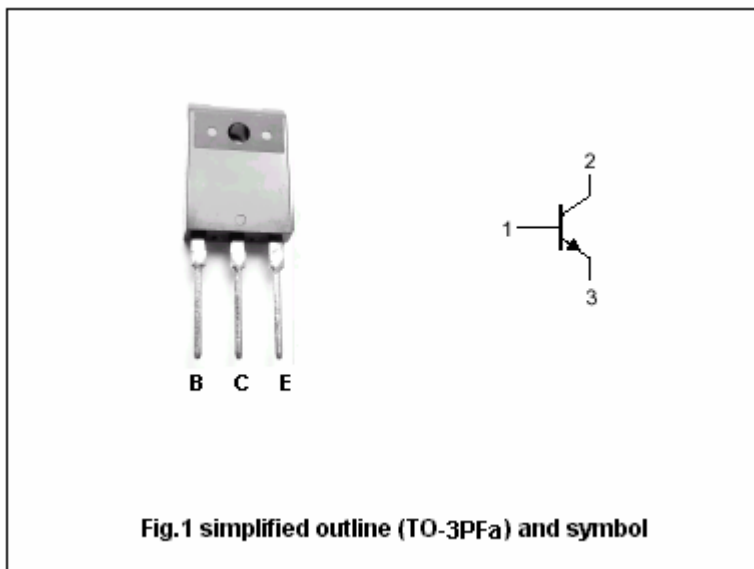
Absolute maximum ratings( $T_a=25^\circ\text{C}$ )

SYMBOL	PARAMETER	CONDITIONS	VALUE	UNIT
$V_{CBO}$	Collector-base voltage	Open emitter	1500	V
$V_{CEO}$	Collector-emitter voltage	Open base	800	V
$V_{EBO}$	Emitter-base voltage	Open collector	7.5	V
$I_C$	Collector current (DC)		12	A
$I_{CM}$	Collector current-peak		30	A
$I_B$	Base current (DC)		8	A
$I_{BM}$	Base current-peak		12	A
$P_{tot}$	Total power dissipation	$T_C=25^\circ\text{C}$	45	W
$T_j$	Junction temperature		150	$^\circ\text{C}$
$T_{stg}$	Storage temperature		-65~150	$^\circ\text{C}$

## Silicon NPN Power Transistors

## BU2527AF

## CHARACTERISTICS

T<sub>j</sub>=25°C unless otherwise specified

SYMBOL	PARAMETER	CONDITIONS	MIN	TYP.	MAX	UNIT
V <sub>CEO(SUS)</sub>	Collector-emitter sustaining voltage	I <sub>C</sub> =100mA ; I <sub>B</sub> =0, L=25mH	800			V
V <sub>(BR)EBO</sub>	Emitter-base breakdown voltage	I <sub>E</sub> =1mA ; I <sub>C</sub> =0	7.5			V
V <sub>CEsat</sub>	Collector-emitter saturation voltage	I <sub>C</sub> =6A ; I <sub>B</sub> =1.2A			5.0	V
V <sub>BEsat</sub>	Base-emitter saturation voltage	I <sub>C</sub> =6A ; I <sub>B</sub> =1.2A			1.3	V
I <sub>CES</sub>	Collector cut-off current	V <sub>CE</sub> =BV <sub>CES</sub> ; V <sub>BE</sub> =0 T <sub>j</sub> =125°C			0.25 2.0	mA
I <sub>EBO</sub>	Emitter cut-off current	V <sub>EB</sub> =7.5V; I <sub>C</sub> =0			0.25	mA
h <sub>FE-1</sub>	DC current gain	I <sub>C</sub> =1A ; V <sub>CE</sub> =5V		10		
h <sub>FE-2</sub>	DC current gain	I <sub>C</sub> =6A ; V <sub>CE</sub> =5V	5		9	
C <sub>C</sub>	Collector capacitance	V <sub>CB</sub> =10V; I <sub>E</sub> =0; f=1.0MHz		145		pF

Silicon NPN Power Transistors

BU2527AF

PACKAGE OUTLINE

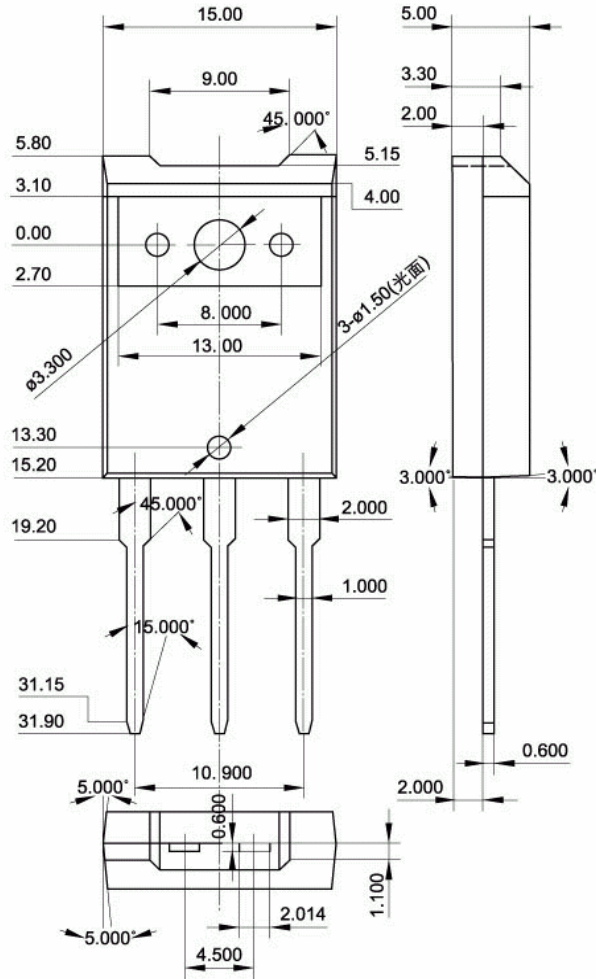

Fig.2 Outline dimensions (unindicated tolerance:±0.30mm)