Blood Pressure Monitor Using the Flexis QE128 Family

Design Reference Manual

Devices Supported:

MC9S08QE128

MCF51QE128

MPR083

MR2A16A

MC9S08JM60

MC13202

MPXV5050

Document Number: DRM101

Rev. 0

07/2008

How to Reach Us:

Home Page:

www.freescale.com

E-mail:

support@freescale.com

USA/Europe or Locations Not Listed:

Freescale Semiconductor
Technical Information Center, CH370
1300 N. Alma School Road
Chandler, Arizona 85224
+1-800-521-6274 or +1-480-768-2130
support@freescale.com

Europe, Middle East, and Africa:

Freescale Halbleiter Deutschland GmbH
Technical Information Center
Schatzbogen 7
81829 Muenchen, Germany
+44 1296 380 456 (English)
+46 8 52200080 (English)
+49 89 92103 559 (German)
+33 1 69 35 48 48 (French)
support@freescale.com

Japan:

Freescale Semiconductor Japan Ltd.
Headquarters
ARCO Tower 15F
1-8-1, Shimo-Meguro, Meguro-ku,
Tokyo 153-0064, Japan
0120 191014 or +81 3 5437 9125
support.japan@freescale.com

Asia/Pacific:

Freescale Semiconductor Hong Kong Ltd.
Technical Information Center
2 Dai King Street
Tai Po Industrial Estate
Tai Po, N.T., Hong Kong
+800 26668334
support.asia@freescale.com

For Literature Requests Only:

Freescale Semiconductor Literature Distribution Center
P.O. Box 5405
Denver, Colorado 80217
1-800-441-2447 or 303-675-2140
Fax: 303-675-2150
LDCForFreescaleSemiconductor@hibbertgroup.com

Information in this document is provided solely to enable system and software implementers to use Freescale Semiconductor products. There are no express or implied copyright licenses granted hereunder to design or fabricate any integrated circuits or integrated circuits based on the information in this document.

Freescale Semiconductor reserves the right to make changes without further notice to any products herein. Freescale Semiconductor makes no warranty, representation or guarantee regarding the suitability of its products for any particular purpose, nor does Freescale Semiconductor assume any liability arising out of the application or use of any product or circuit, and specifically disclaims any and all liability, including without limitation consequential or incidental damages. "Typical" parameters that may be provided in Freescale Semiconductor data sheets and/or specifications can and do vary in different applications and actual performance may vary over time. All operating parameters, including "Typicals", must be validated for each customer application by customer's technical experts. Freescale Semiconductor does not convey any license under its patent rights nor the rights of others. Freescale Semiconductor products are not designed, intended, or authorized for use as components in systems intended for surgical implant into the body, or other applications intended to support or sustain life, or for any other application in which the failure of the Freescale Semiconductor product could create a situation where personal injury or death may occur. Should Buyer purchase or use Freescale Semiconductor products for any such unintended or unauthorized application, Buyer shall indemnify and hold Freescale Semiconductor and its officers, employees, subsidiaries, affiliates, and distributors harmless against all claims, costs, damages, and expenses, and reasonable attorney fees arising out of, directly or indirectly, any claim of personal injury or death associated with such unintended or unauthorized use, even if such claim alleges that Freescale Semiconductor was negligent regarding the design or manufacture of the part.



Freescale™ and the Freescale logo are trademarks of Freescale Semiconductor, Inc. All other product or service names are the property of their respective owners.

© Freescale Semiconductor, Inc. 2008. All rights reserved.

DRM101
Rev. 0
07/2008

Chapter 1 Preface

1.1	Preface	1-1
1.2	Audience	1-1
1.3	Suggested Reading	1-1

Chapter 2 Introduction

2.1	Intended Functionality	2-1
2.2	Solution Benefits	2-1
2.3	Quick Start	2-2
2.3.1	SMAC GUI Setup	2-3
2.3.2	Sensor Reference Board Setup	2-4
2.3.3	BPM Setup	2-5
2.4	Using the Blood Pressure Monitor	2-9
2.5	Navigation	2-9
2.6	Sending Data to a PC	2-14

Chapter 3 Hardware Description

3.1	Introduction	3-1
3.2	Operating Environment	3-1
3.3	Flexis MC9S08QE128 and MCF51QE128 Microcontrollers	3-1
3.3.1	MC9S08QE128 Microcontroller	3-2
3.3.2	MCF51QE128 Microcontroller	3-2
3.4	MPR083 Proximity Sensor	3-2
3.5	MR2A16A Asynchronous Magnetoresistive RAM	3-3
3.6	MC9S08JM60 Microcontroller	3-3
3.7	MC13202 ZigBee Transceiver	3-4
3.8	MPXV5050 Pressure Sensor	3-4
3.9	OSRAM Pictiva OLED Display OS128064PK27MY0B00	3-4
3.10	PCB Layout	3-5
3.10.1	Mechanical Characteristics	3-6

Chapter 4 Embedded Software Description

4.1	Introduction	4-1
4.2	Software Design Goals	4-1
4.3	Software Architecture	4-1
4.4	Software	4-2
4.4.1	Blood Pressure Measurement	4-2
4.4.2	Capacitive Touch	4-2
4.4.3	MRAM Storage	4-4
4.4.4	OLED Display	4-4

4.4.5	USB Communication	4-4
4.4.6	Voice Generation	4-4
4.4.7	ZigBee Communication	4-5

Chapter 5
Customizing the Blood Pressure Monitor

Appendix A
Schematics

Appendix B
Bill of Materials

Chapter 1

Preface

The revision history table summarizes changes contained in this document.

Date	Revision Level	Description	Page Number
11/12/07	Rev. 0	First Draft	

1.1 Preface

This design reference manual provides all guidelines and considerations used in the development of the blood pressure monitor (BPM) reference design. It contains descriptions of the hardware, the software architecture, the packages employed in the implementation, and the application-specific software developed for creating the system.

1.2 Audience

This document is intended for application developers who wish to learn how to set up the blood pressure monitor reference design, as well as those who wish to use a specific part of this reference design and append it to their own application.

1.3 Suggested Reading

- MC9S08QE128 reference manual
- MC9S08JM60 data sheet
- MR2A16A data sheet
- MPR083 data sheet
- MC13202 data sheet
- Application note AN3500 – *Blood Pressure Monitor Using Flexis QE128*
- Application note AN3415 – *OLED Display Driver for the HCS08 Family*
- Application note AN2250 – *Audio Reproduction on HCS12 Microcontrollers*

Additional documentation may be found at www.freescale.com.

Chapter 2

Introduction

2.1 Intended Functionality

The blood pressure monitor (BPM) reference design shows how to implement a system that can measure arterial blood pressure values. The system demonstrates control, data retention, analog acquisition, and connectivity functions, as well as the ability to interface with a user. These are achieved by using several Freescale devices.

This reference design serves only as a proof of concept for this application and is not authorized for use in safety-critical applications such as a U.S. Food and Drug Administration (FDA) class 3 application. Manufacturers and designers who incorporate Freescale (FSL) technology must have all necessary expertise in the safety and regulatory ramifications involved in the application of this design, and they are solely responsible for all legal, regulatory, and safety-related requirements concerning their products and the use of Freescale devices in safety-critical applications.

2.2 Solution Benefits

The BPM reference design elements can be referenced for later development as:

- USB communication using the MC9S08JM60 as a bridge
- 2.4 GHz communication using the MC13202 ZigBee transceiver
- MRAM communications
- Use of MRAM to store user data
- MRAM driver to access MRAM memory
- User display using an OLED display
- User interface using the MPR083 proximity sensor
- Audio feedback using two timer pulse-width modulator (TPM) modules

The main benefit from this solution is that developers are able to take any piece of hardware and/or software and reuse it for their own applications, thus enhancing the design cycle and providing faster development time.

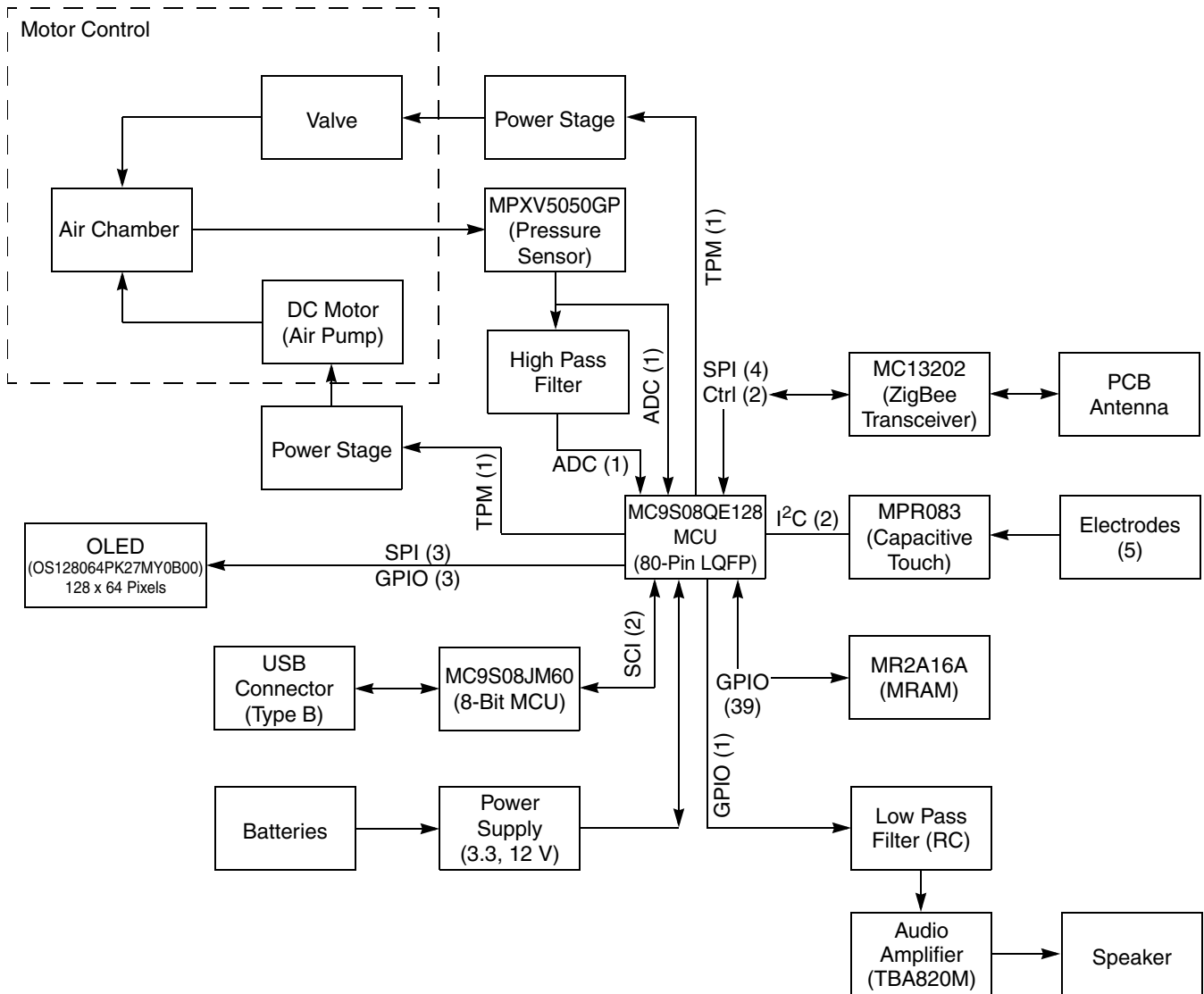

Figure 2-1. Flexis BPM Reference Design Block Diagram

2.3 Quick Start

This section sets up the system and explains the BPM reference design and how to use it. The reference design consists of:

- The BPM system
- A cuff
- A PC software interface
- A 1321x-SRB (sensor reference board) for ZigBee communication

The next subsections contain the general steps needed to properly set up and run the BPM reference design.

2.3.1 SMAC GUI Setup

Install the PC software, which enables the user to download data from the system onto a computer. Make sure that the user on the computer has administrative privileges to perform this installation.

1. First double-click on the Freescale SMAC GUI installer.



This will open the installation screen.

2. Click on the Next button. Now you will see a window that shows the installation route where the GUI will be installed. Please note that you cannot change the destination folder for the program, but you can see how much space will be required by the installation and how much free space the system has.
3. Click on the Next button to continue. The system will now install the necessary files into your system. At the end of the installation you should see a window saying that the installation has been completed.
4. You will then be prompted to install the USBIO driver package. This package installs the USB drivers onto your computer.

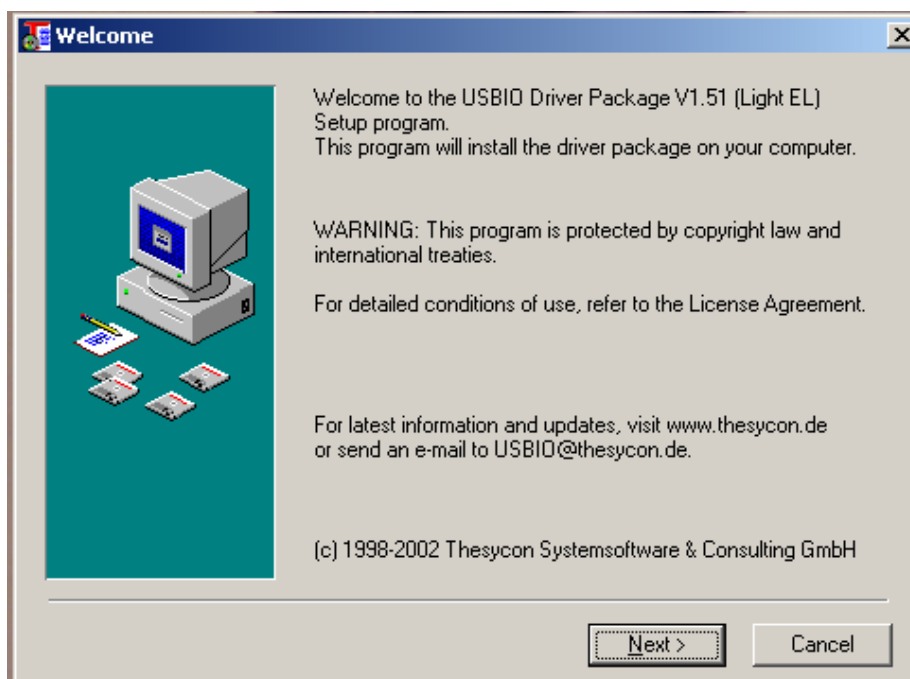

5. Obey the instructions to install these drivers.
6. After the program has finished installing the driver, you will see the Installation Complete window.
7. After the USBIO driver package installation is complete, you will be asked to install the Freescale ZigBee/802.15.4 MAC COM device driver set. It is important that the user also install this driver so that the system will work properly.

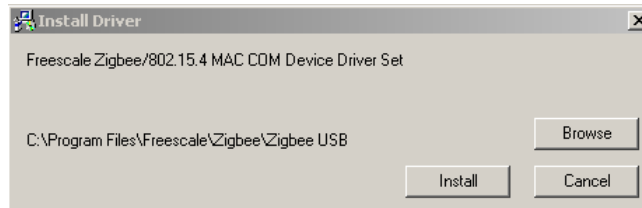

After these three drivers are installed, the SMAC GUI will work properly with the computer.

2.3.2 Sensor Reference Board Setup

1. Attach the sensor reference board (SRB) when the power switch is in the OFF position.
2. Turn on the SRB. If necessary, install the new USB hardware on your computer.



3. Click on Next.
4. Your system will then find the necessary files and install the USB device on your PC. After the installation has finished you will see a screen that says “Completing the Found New Hardware Wizard.”

- After it has installed, you will then be asked to install the COM device:



- Click on Next.
- Your system will then install the necessary DLL files. After they have been installed you will see a screen that says “Completing the Found New Hardware Wizard.”
- After the hardware has been installed you will be able to use the SRB with the Blood Pressure Monitor Demo.

NOTE

Please note that you must install both USB component devices for each sensor reference board that you connect to your computer. Otherwise the PC will not be able to communicate with the SRB.

2.3.3 BPM Setup

- Select the desired Flexis MCU and place it into the BPM reference design socket. Select MC9S08QE128 for down-ramp measurement or MCF51QE128 for up-ramp measurement.
- Power on the BPM reference design.
- Connect the USB connector to the BPM reference design. After it is connected, the PC will see that a new hardware device has been found and will ask you if you want to install its driver.

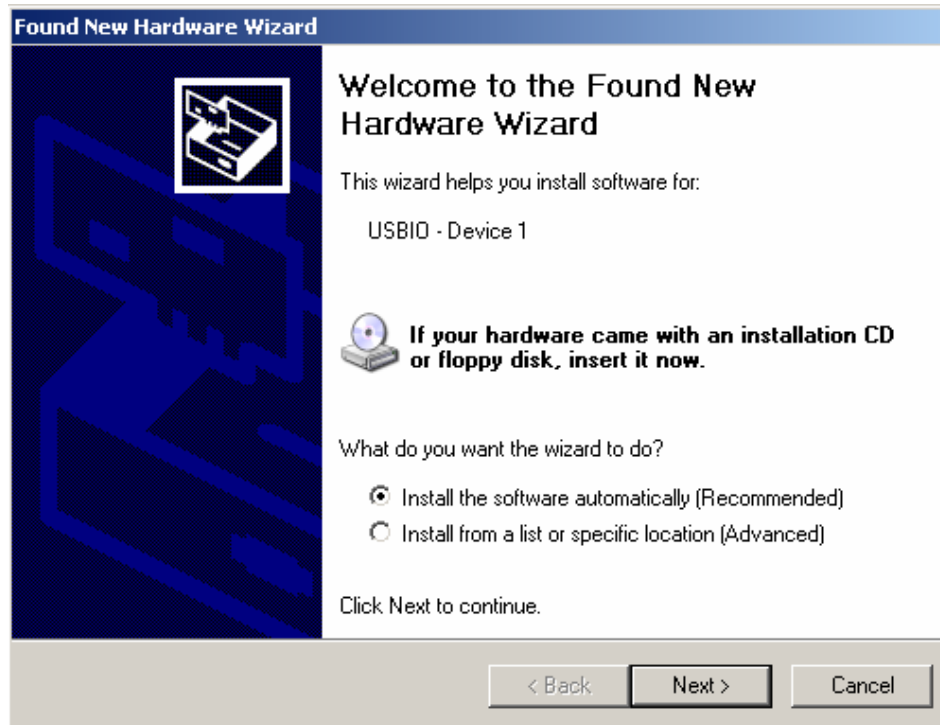

4. Install the new hardware driver onto the PC.

5. From the Windows Start menu, run the Freescale SMAC GUI. When it starts, you will see this screen:

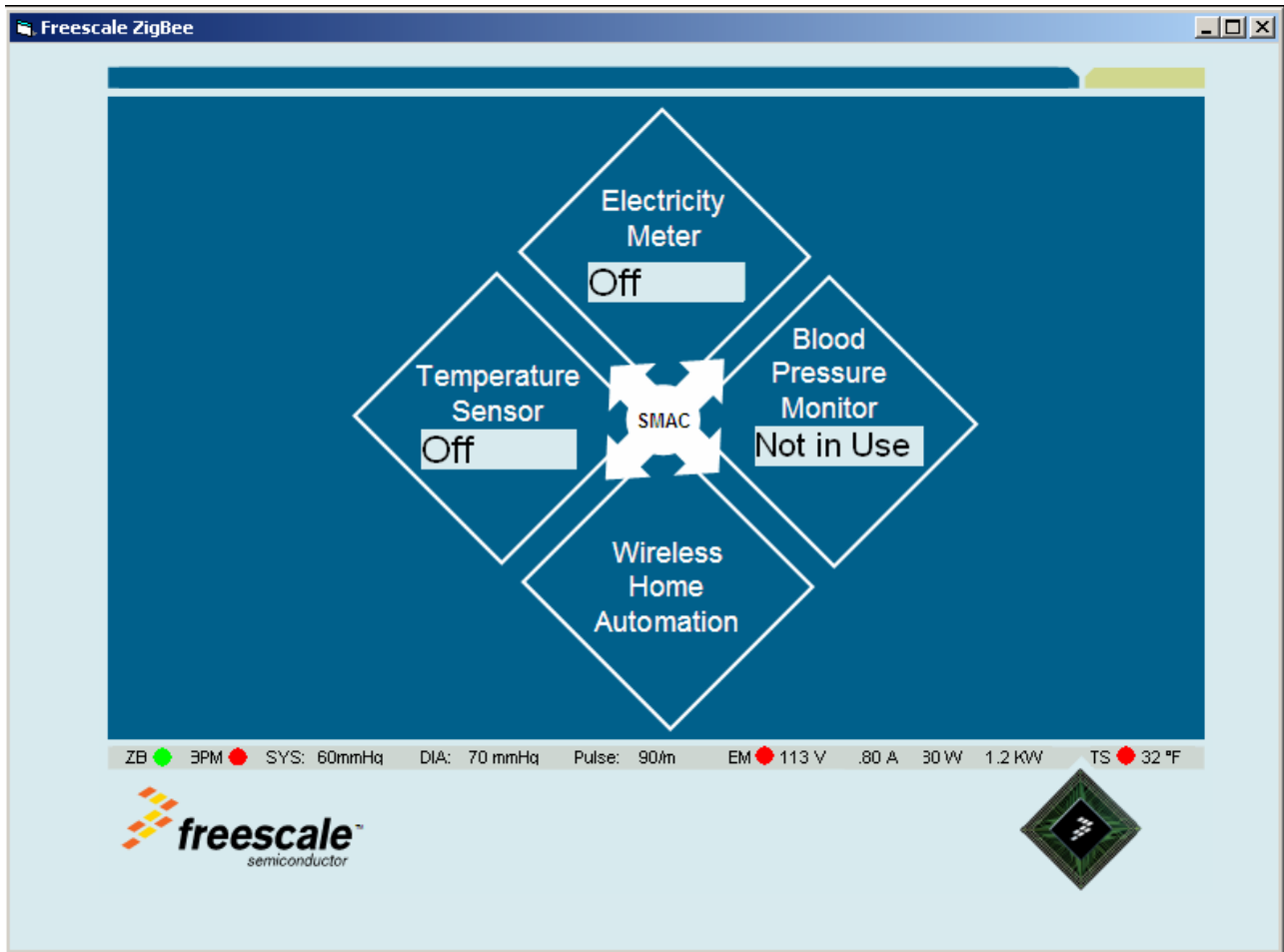

6. Within the Freescale SMAC GUI, click on the Blood Pressure Monitor icon. This icon will open a new window with the blood pressure monitor's previously stored graphs.

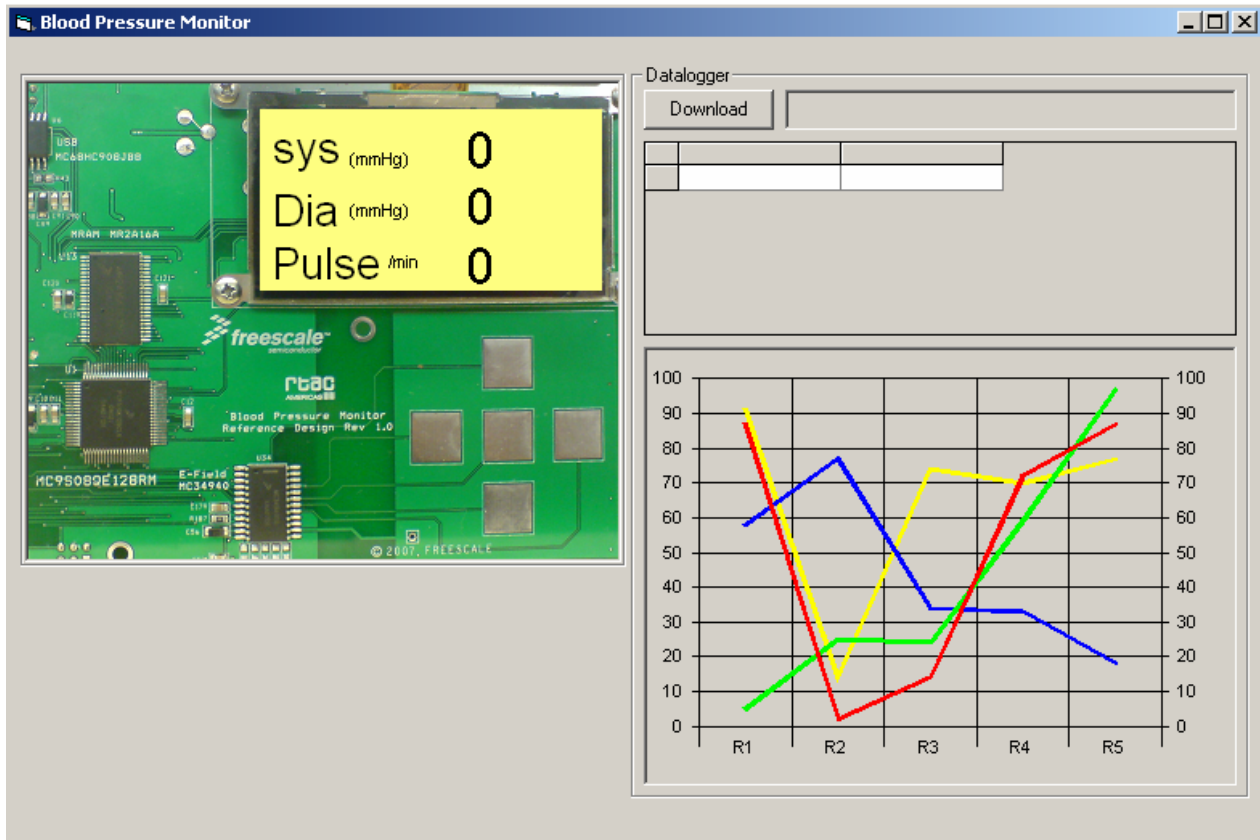

The application is now running. It is possible to use the arrow keys to navigate through the system menus and configure the settings. The user can set the audio on or off as well as enable and disable USB and wireless connectivity.

2.4 Using the Blood Pressure Monitor

When a user plugs in the blood pressure monitor, a splash screen with the Freescale logo will appear. The logo will scroll in from the right, and after it reaches the center scroll down and leave the OLED display.



While this is happening, the pressure sensor stabilizes and auto-calibrates itself according to the atmospheric pressure. After the splash screen has exited, a home screen will appear. Here the user is able to navigate and use the blood pressure monitor demo.

2.5 Navigation

The home screen contains an icon of a heart with the word “Start” under it, and an icon of a folder, with a hammer and screwdriver, that has the word “Options” under it. Whichever item is selected will have a larger size than the other, and the words under the image will appear inside a yellow box, resembling a highlight. This highlighting is used on all screens to indicate a selected item.

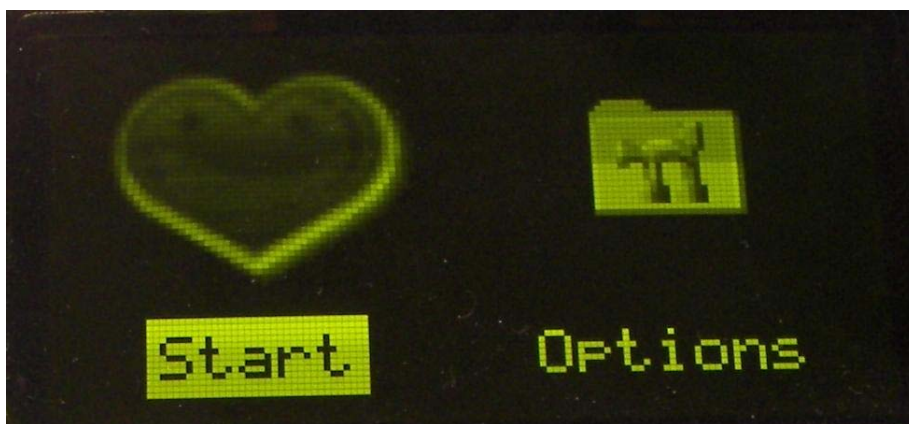

Figure 2-2. Home Screen with Start Selected

Movement within the options can be done by pressing the buttons on the board. The left and right buttons switch between the Start and Options items, and the center button acts as an enter button.

If the user selects the start option, the device will begin taking a blood pressure measurement.

Introduction

After the blood pressure measurement is finished, a screen will come up showing the blood pressure measurement taken by the system. If audio is enabled, the user will hear the measured values through a small speaker within the Blood Pressure Monitor.

By pressing the up and down buttons, the user can see the historical measurement data of the systolic pressure, diastolic pressure, and pulse rate. After users are finished, they can press the center button to return to the home screen.

By selecting the Options menu, the user will now be able to modify more advanced features of the blood pressure monitor. Navigation within the Options menu is done using the up and down buttons. The user is also able to return to the home screen by pressing the left button. Within the Options menu, a user has the ability to change the settings seen here:



Language: the blood pressure monitor can be set to present user data in English, Spanish, French, and German. Choose one, and the system will show commands and deliver audio feedback in the selected language.

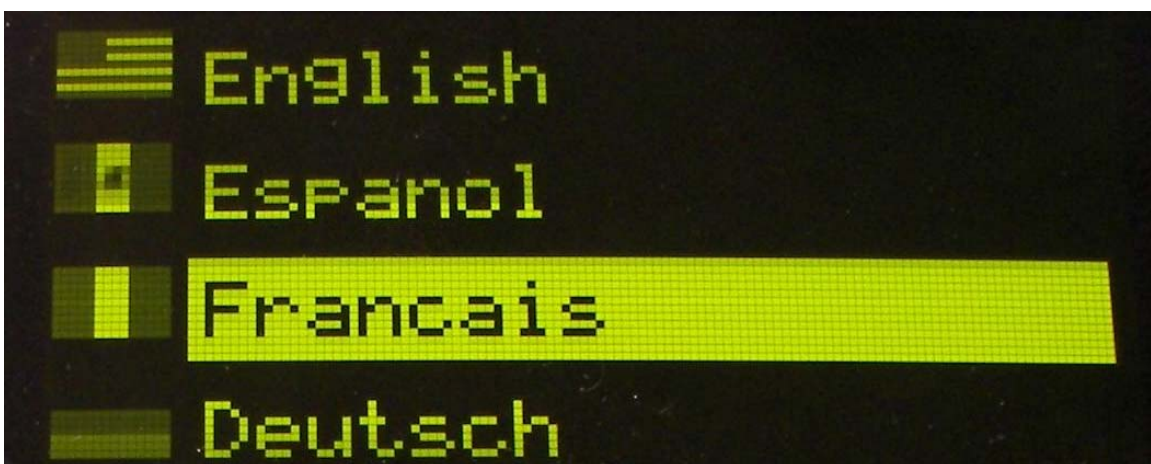

After the user selects a language, the blood pressure monitor will return to the Options menu and display the items in the new selected language. Users can also return to the Options menu without modifying the default language by pressing the left button.

Audio: pressing the center button when the Audio item is selected will toggle the audio preferences of the blood pressure monitor. Users can see whether or not the audio is on by the state of the speaker icon on the left. Here is an example of how the icons look when the audio is on and when it is off:

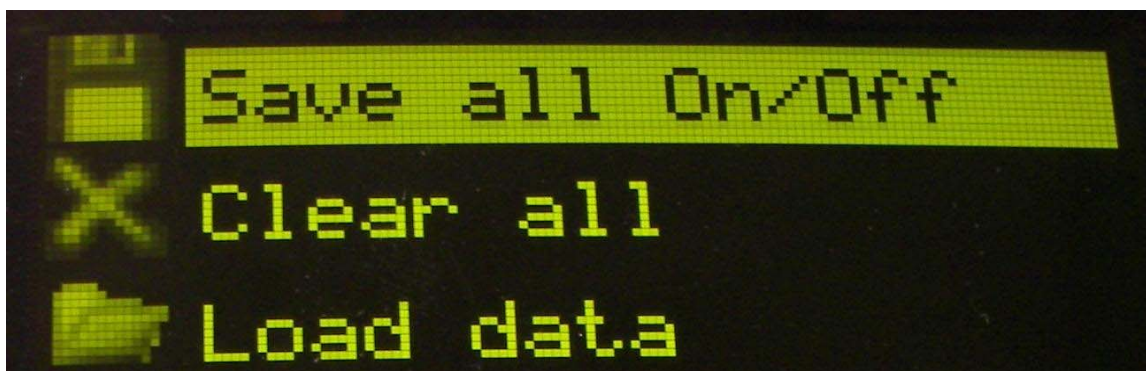

Figure 2-3. Audio Feedback On



Figure 2-4. Audio Feedback Off

Memory: within this menu, the user will have the ability to manipulate the options associated with data logging. There is also the ability to view past measurements in a graphical format. To return to the Options menu, press the left button.



The first option allows users to enable measurement storage to MRAM. When storage is enabled, the latest measurement taken on the blood pressure monitor will be stored. The blood pressure monitor can store up to five readings (sets of measurements) on the system at a time.



Figure 2-5. Save Option On



Figure 2-6. Save Option Off

The second option clears all data stored on the MRAM.



The third option enables users to load and view the historical data that has been taken by the blood pressure monitor in the same format as when a measurement was taken.



By selecting this option and pressing the center button, the user will see the past systolic pressures that have been taken.



Here the user can press the up and down buttons to change between the systolic pressure, diastolic pressure, and heart rate. To leave this mode, the user must press the center button to return to the Options menu.

Connectivity: in this menu, users can adjust the ability of the blood pressure monitor to send data using either the USB connection on the board, and/or the wireless ZigBee chip on the board. Users can see which communication modes are enabled by seeing the icon on the left of the screen, the same as with the audio icon.

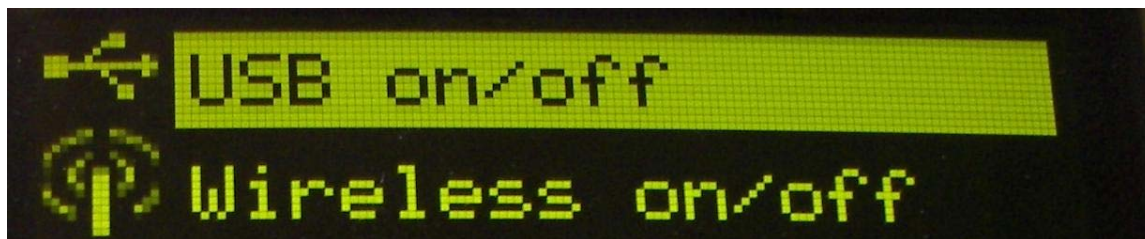

Figure 2-7. USB and Wireless Connectivity On



Figure 2-8. USB and Wireless Connectivity Off

To return to the Options menu, press the left button.

Periodical Measurements: this enables measurements for the blood pressure monitor at specified intervals of 5, 10, 15, and 20 minutes. After the user selects an option, the blood pressure monitor will return to the Options menu. It is also possible to return to the Options menu without making changes. The blood pressure monitor will begin to take periodic measurements based on the time interval that has been selected.

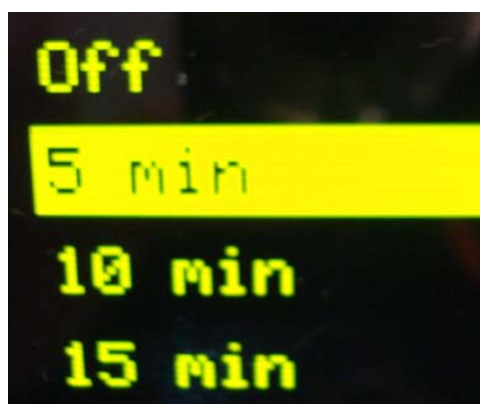
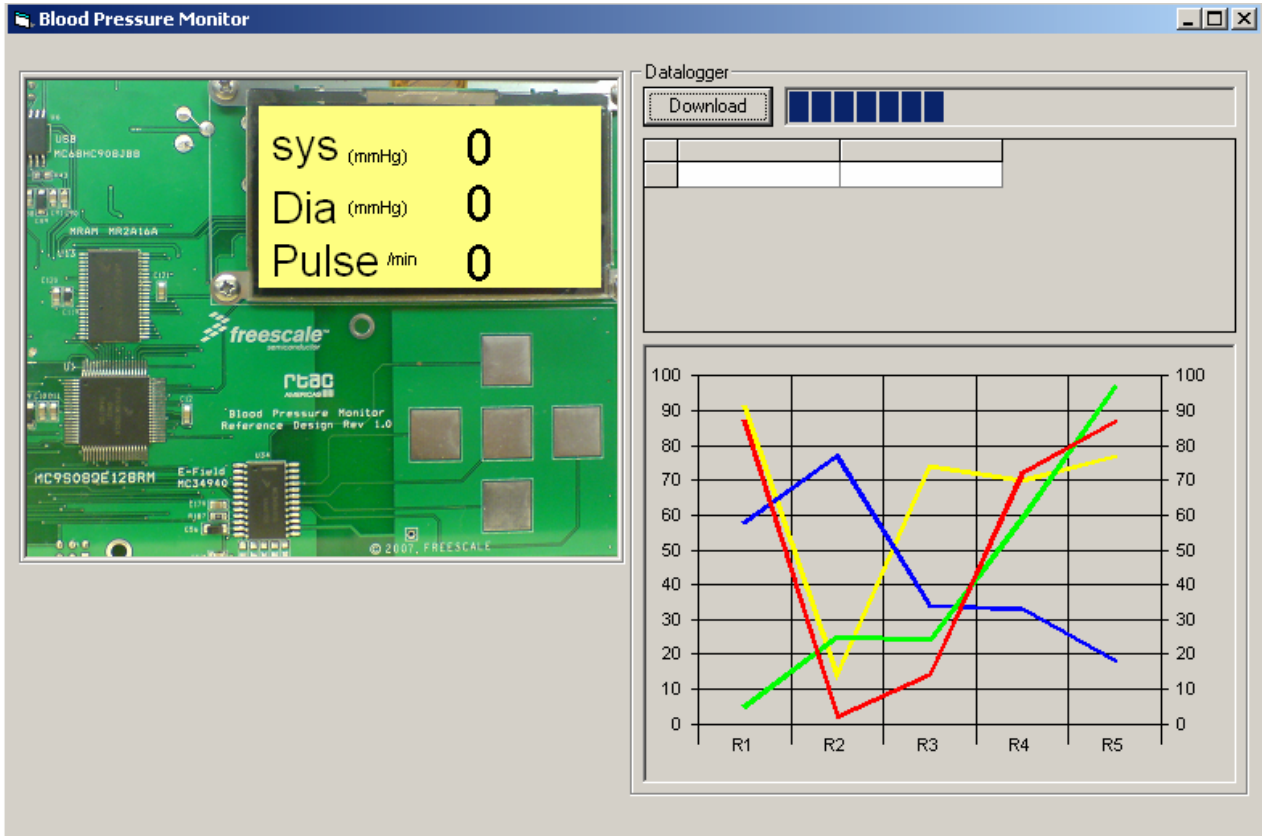

Figure 2-9. Periodic Measurements

2.6 Sending Data to a PC

When the blood pressure monitor is connected to the PC through USB, the user can download the last five measurements taken from the system. To do this, the user needs to open the Blood Pressure window from the Home Automation user interface. In the new window that opens, the user can click on the download button on the top right of the screen. The user interface will then begin to download the last five measurements from the blood pressure monitor.



After it has finished, the last five measurements will be displayed in a table and graphed on the screen.

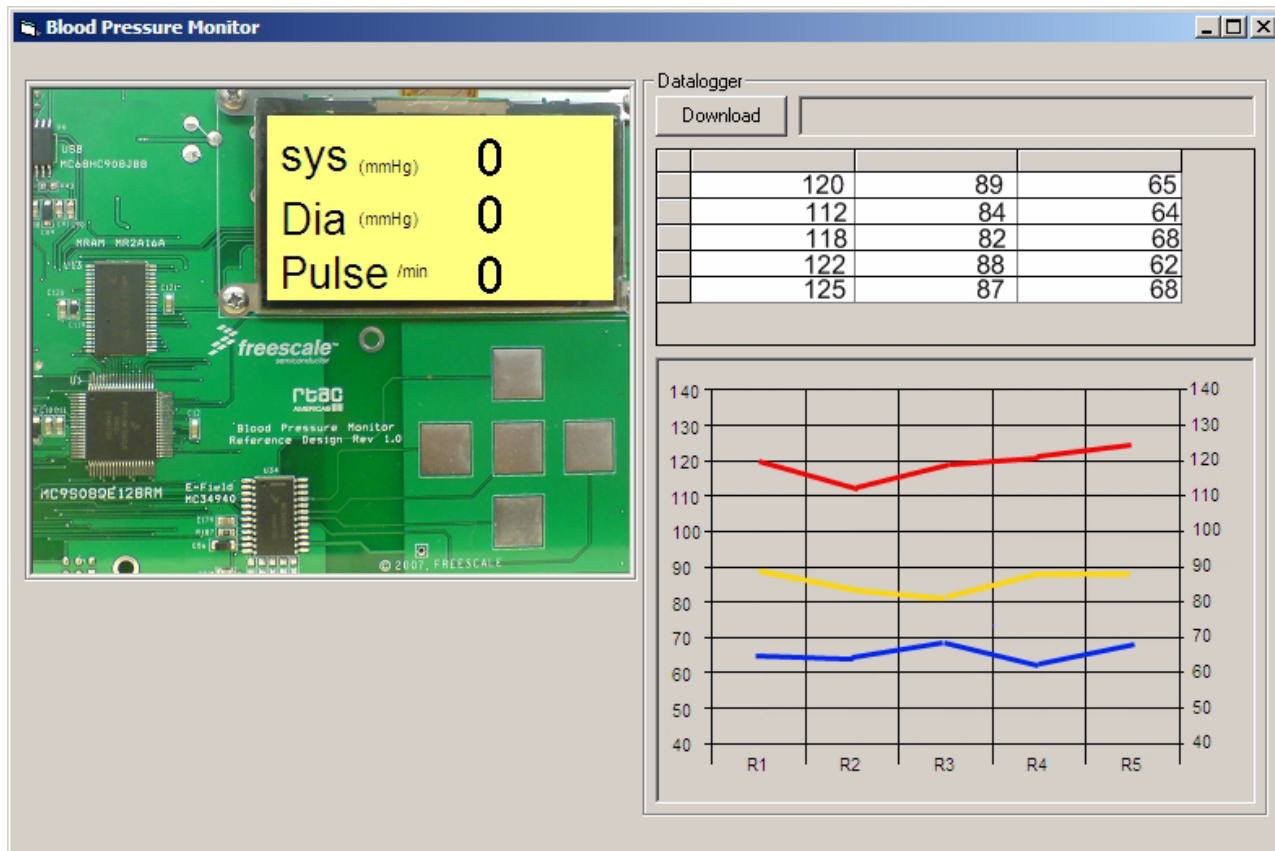

This feature allows users to connect the blood pressure monitor to a PC and retrieve past patient measurements.

Chapter 3

Hardware Description

3.1 Introduction

The design for the BPM PCB was made with the intention of isolating the different blocks of the system to avoid letting coupling noise into the lines of the instrumentation amplifier. The power is segmented through the use of $0\ \Omega$ resistors for debugging. These resistors can be replaced by ferrite cores to suppress EMI and noise coming from the different portions of the board. Ground distribution was implemented using a star configuration.

Another feature of the board is the test socket which eases the change between the S08 and the ColdFire device.

This section provides the technical descriptions for the Freescale BPM system, and for the Freescale components used in the reference design. These Freescale components are:

- Flexis MC9S08QE128 Microcontroller
- Flexis MCF51QE128 Microcontroller
- MPR083 Proximity Sensor
- MR2A16A Asynchronous Magnetoresistive RAM
- MC9S08JM60 Microcontroller
- MC13202 ZigBee Transceiver
- MPXV5050 Pressure Sensor
- OSRAM Pictiva OLED Display OS128064PK27MY0B00

3.2 Operating Environment

- Input voltage: 9 VDC
- Input current: 800 mA minimum, 1 A maximum
- Operating temperature: 0 to +65 °C
- Operating humidity: 90% RH maximum for T_A 40 °C

3.3 Flexis MC9S08QE128 and MCF51QE128 Microcontrollers

The Flexis QE128 microcontrollers are Freescale's revolutionary 8-bit and 32-bit compatible devices. They offer unprecedented compatibility, and have a common set of on-chip peripherals and development tools. They maintain pin-to-pin compatibility, which enables a developer to create one common hardware platform and use that platform for more than one product with different computing capabilities.

Flexis QE128 features:

- Up to 50 MHz CPU frequency from 3.6 V to 2.1 V, and 20 MHz CPU frequency at 2.1 V to 1.8 V, across a temperature range of -40°C to 85°C
- 128 KB flash and 8 KB RAM
- Peripheral clock enable register, to disable clocks to unused modules
- Enhanced 24-channel, 12-bit analog-to-digital converter (ADC)

3.3.1 MC9S08QE128 Microcontroller

The MC9S08QE128 MCU is a highly integrated member of Freescale's 8-bit family of microcontrollers that is based on the high-performance, low-power consumption HCS08 core. The MC9S08QE128 MCU includes a background debugging system and on-chip, in-circuit emulation (ICE) with real-time bus capture, providing a single-wire debugging and emulation interface. It also features a programmable 16-bit timer/pulse-width-modulation module that is one of the most flexible and cost-effective of its kind. The compact, tightly integrated MC9S08QE128 MCU delivers a versatile combination of Freescale peripherals along with the advanced features of the HCS08 core, including extended battery life with maximum performance down to 1.8 V, industry-leading flash, and innovative development support.

MC9S08QE128 features:

- Support for up to 32 interrupt/reset sources
- New MMU allows access of up to 4 MB through paging
- New linear address pointer to access all memory on the MCU
- SET/CLR/TOGGLE registers on 16 pins (PTC and PTE)

3.3.2 MCF51QE128 Microcontroller

The MCF51QE128 microcontroller extends the low end of the ColdFire family with up to 128 KB flash memory and a 24-channel, 12-bit analog-to-digital converter (ADC). The 32-bit QE128 includes up to 3.3 V supply voltage, a 50.33 MHz CPU core, and three timers for improved motor control.

MCF51QE128 features:

- Implements ColdFire V1 instruction set revision C
- Support for up to 30 peripheral interrupt requests and seven software interrupts
- Single-wire background debug interface
- 16 bits of Rapid GPIO connected to the CPU's high-speed local bus with set, clear, and toggle functionality

3.4 MPR083 Proximity Sensor

The MPR083 is an IIC-driven capacitive touch sensor controller, optimized to manage an 8-position rotary-shaped capacitive array. This device can accommodate a wide range of implementations through three output mechanisms and many configurable options.

Freescale Semiconductor's MPR083 proximity-capacitive touch sensor controller is designed to detect the state of capacitive touch pads. The MPR083 offers designers a cost-efficient alternative to mechanical rotary switches for control panel applications.

The MPR083 uses an IIC interface to communicate with the host which configures the operation, and an interrupt to advise the host of status changes. The MPR083 also includes a piezo sounder drive which provides audible feedback to simulate mechanical key clicks.

MPR083 features:

- 1.8 V to 3.6 V operation
- 150 μ A average supply current
- 35 μ A low power mode
- Variable low power mode response time (10 ms–10 s)

3.5 MR2A16A Asynchronous Magnetoresistive RAM

The MR2A16A is a 4,194,304-bit magnetoresistive random access memory (MRAM) device organized as 262,144 words of 16 bits. The MR2A16A is equipped with chip enable (E), write enable (W), and output enable (G) pins, allowing for significant system design flexibility without bus contention. Because the MR2A16A has separate byte-enable controls (LB and UB), individual bytes can be written and read.

MRAM is a nonvolatile memory technology that protects data in the event of power loss and does not require periodic refreshing. The MR2A16A is the ideal memory solution for applications that must permanently store and retrieve critical data quickly.

MR2A16A features:

- Single 3.3 V power supply
- Commercial temperature range (0 °C to 70 °C)
- Flexible data bus control — 8-bit or 16-bit access
- Equal address and chip-enable access times
- Automatic data protection with low-voltage inhibit circuitry to prevent writes on power loss
- All inputs and outputs are transistor-transistor logic (TTL) compatible
- Full nonvolatile operation with 10 years minimum data retention

3.6 MC9S08JM60 Microcontroller

The MC9S08JM60 series MCUs are members of the low-cost, high-performance HCS08 family of 8-bit microcontroller units (MCUs). The JM family features a fully-compliant full-speed USB 2.0 device peripheral, which enables users to connect to a PC or any other USB host.

MC9S08JM60 features:

- 48 MHz CPU frequency
- 2.7 V to 5.5 V operating voltage
- 60 KB of on-chip flash

- 4 KB of on-chip RAM
- USB 2.0 Full Speed (12 Mbps) with dedicated on-chip 3.3 V regulator; supports control, interrupt, isochronous, and bulk transfers; supports endpoint 0 and up to six additional endpoints; endpoints 5 and 6 can be combined to provide double buffering capability

3.7 MC13202 ZigBee Transceiver

The MC13202 is a short-range, low-power, 2.4 GHz industrial, scientific, and medical (ISM) band transceiver. The MC13202 contains a complete packet data modem which is compliant with the IEEE 802.15.4 standard PHY (physical) layer. This allows the development of proprietary point-to-point and star networks based on the 802.15.4 packet structure and modulation format.

Combined with an appropriate microcontroller (MCU), the MC13202 provides a cost-effective solution for short-range data links and networks. Interface with the MCU is accomplished using a four-wire serial peripheral interface (SPI) connection and an interrupt request output which allows for the use of a variety of processors.

MC13202 features:

- 2.0 V to 3.4 V power supply range
- Operating temperature range of $-40\text{ }^{\circ}\text{C}$ to $85\text{ }^{\circ}\text{C}$
- Buffered transmit and receive data packets for simplified use with MCUs
- Three power-down modes for power conservation
- Two internal 16-bit timer comparators
- Programmable frequency clock output for use by MCU
- Seven general-purpose input/output (GPIO) signals

3.8 MPXV5050 Pressure Sensor

The MPX5050/MPXV5050G series piezoresistive transducer combines advanced micromachining techniques, thin-film metallization, and bipolar processing to provide an accurate high-level analog output signal that is proportional to the applied pressure.

MPXV5050 features:

- 2.5% maximum error over $0\text{ }^{\circ}\text{C}$ to $85\text{ }^{\circ}\text{C}$
- Ideally suited for microprocessor-based or microcontroller-based systems
- Temperature compensated over $-40\text{ }^{\circ}\text{C}$ to $+125\text{ }^{\circ}\text{C}$
- Patented silicon shear stress strain gauge

3.9 OSRAM Pictiva OLED Display OS128064PK27MY0B00

OLED displays are a self-emissive technology that normally requires less power than LCD backlights. These displays only consume power if a pixel is turned on. This feature makes OLED displays ideal for battery-powered applications. The specific OLED being used in this application is a 128 x 64 pixel display

driven through a serial port. The OLED has a 4-bit grayscale display that enables each OLED pixel to turn on at 16 different levels of luminance.

3.10 PCB Layout

The top and bottom layers of the PCB are show here. Gerber files are available for download at www.freescale.com.

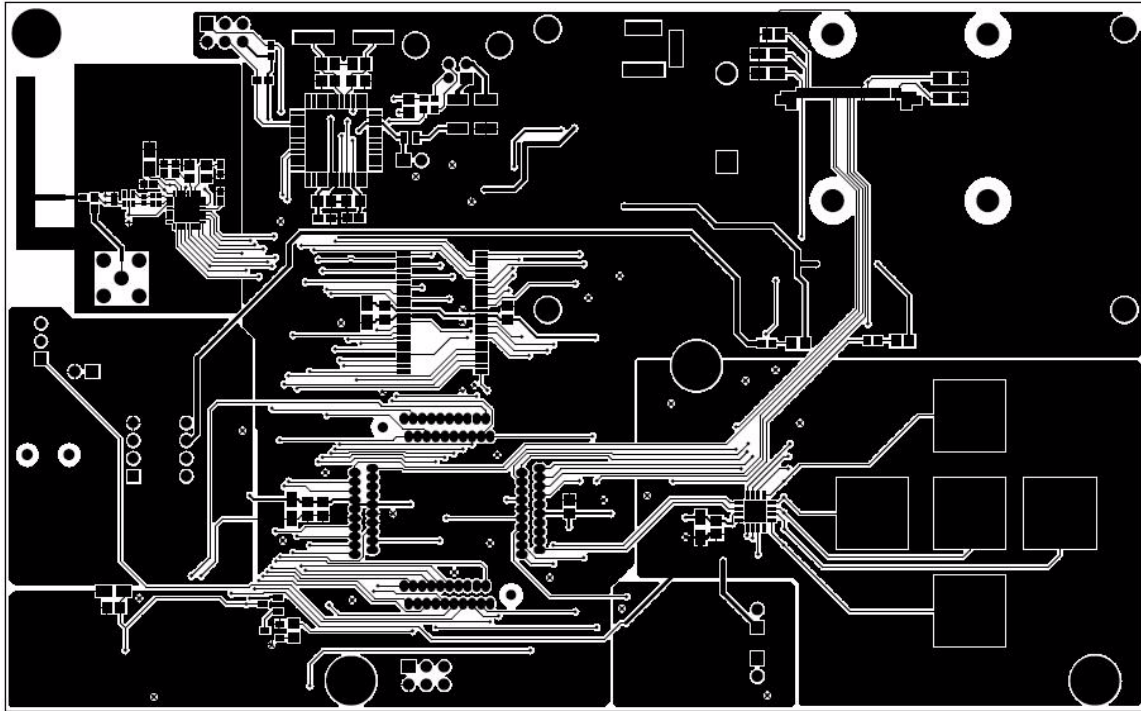

Figure 3-1. Top Layer

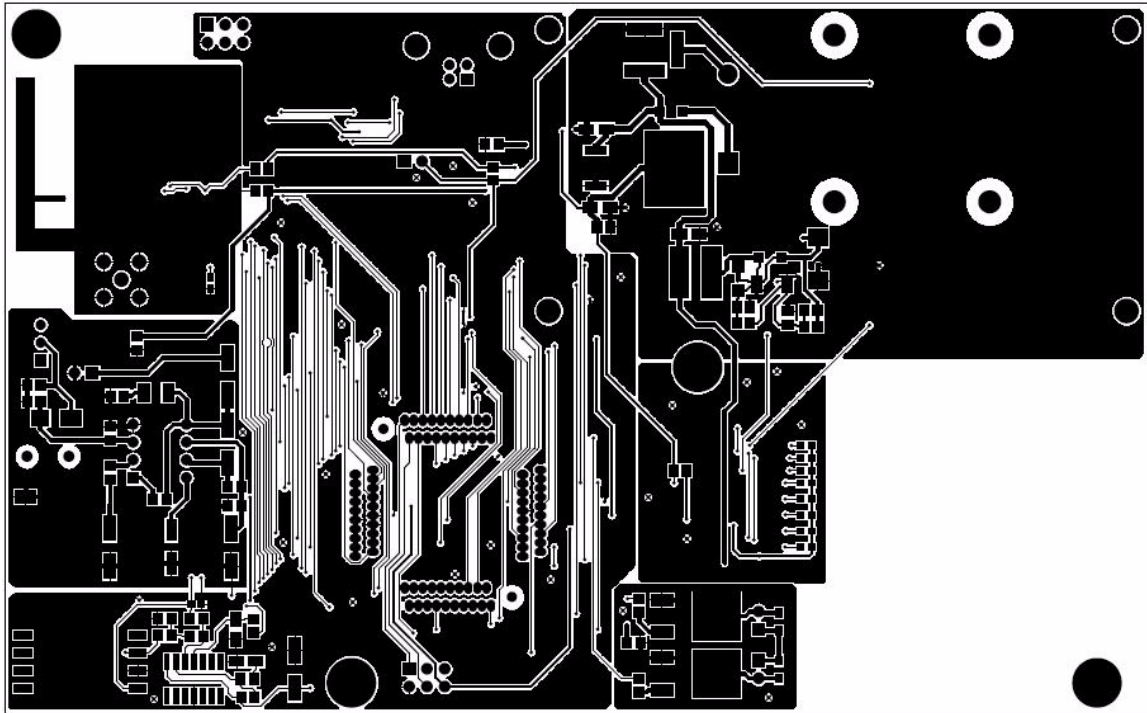

Figure 3-2. Bottom Layer

3.10.1 Mechanical Characteristics

3.10.1.1 Conductor Width and Clearances

The PCB is a rectangle with a size of 6.45 inches by 4 inches with a thickness of 0.064 inch.

The trace widths and clearances for power lines and signal lines are in this table:

Class	Width	Clearance
Regular signals	10	10
Power	20	10

Lines that carry more current, such as the collector lines for the Darlington transistors, have a width of 15 mm. When line widths were determined, current values and copper thickness were taken into account. Standard drill sizes were used for guaranteed manufacturability and ease of production.

3.10.1.2 Trace Angles

One source of RFI is an abrupt change of direction in a PCB track, which effectively looks like impedance discontinuities and will radiate accordingly. For HCMOS designs it is important to ensure that 90-degree track-direction changes do not occur. Also, from the mechanical point of view, a 90-degree angle is more likely to be detached from the board.

3.10.1.3 Placement

When components in the board were situated, the interfaces with the outer casing and the connections to the outputs of the system were taken into consideration. The pressure sensor was placed near the entry point coming from the cuff. Special care was taken to isolate the RF section of the board to avoid noise coupling into the transmitter. The board has different mounting holes for assembly to the casing and the OLED of the system.

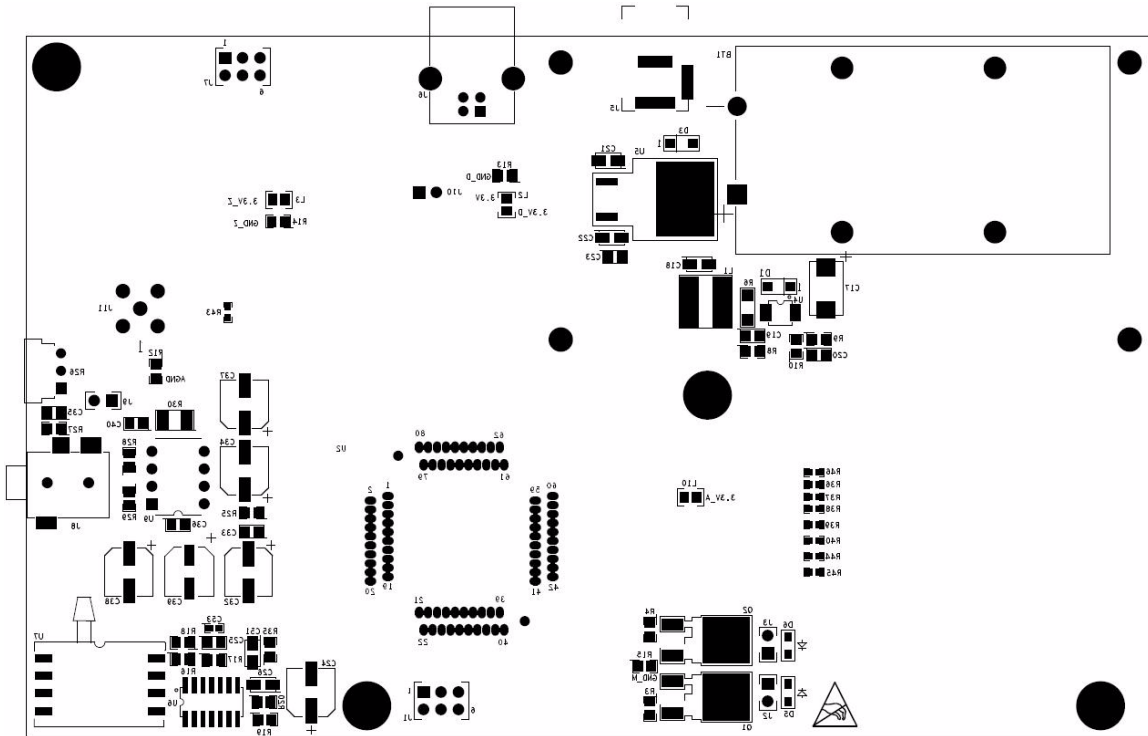

Figure 3-3. Top Placement and Labeling

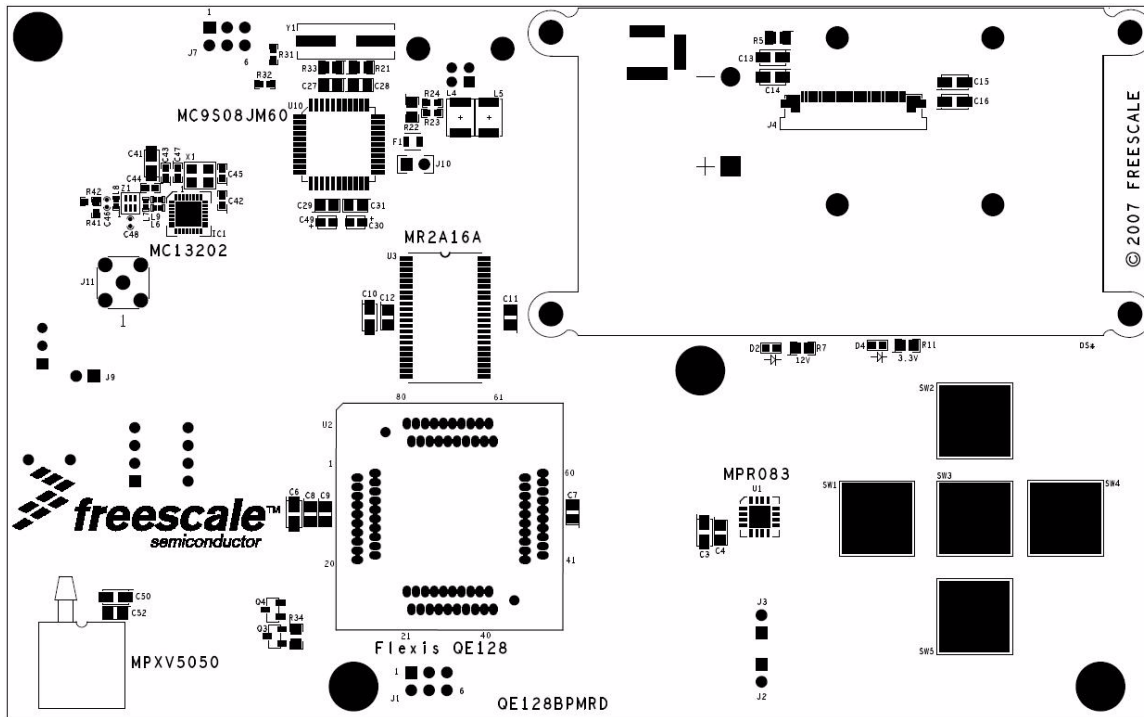

Figure 3-4. Bottom Placement and Labeling

3.10.1.4 Labeling

All parts are outlined in the board, as well as the different supply and GND signals. Two LEDs indicate the power status of the 3.3 V supply (digital, analog, and RF sections) and the 12 V supply (for the OLED and the audio amplifier).

The figures in this chapter and [Table 3-1](#) show the labeling of the supplies and the signals to which they correspond:

Table 3-1. Signals

Name	Signal
3.3 V	General 3.3 V supply for the digital, RF, and analog blocks
3.3 V_D	Supply for the digital block (Flexis and JM60 MCUs)
3.3 V_Z	Supply for the RF block
3.3 V_A	3.3 V supply for the analog blocks (instrumentation amplifier and MPR083 device)
GND_D	Digital ground
GND_Z	RF ground
GND_A	Analog ground
GND_M	Motor block ground

Chapter 4

Embedded Software Description

Here is a description of all the software modules in the blood pressure monitor demo.

4.1 Introduction

The purpose of the blood pressure monitor is to indicate the pulse pressure (the systolic pressure minus the diastolic pressure) of a patient. This is implemented through the use of a cuff wrapped around the patient's arm, and measuring the pressure and pressure differential of that cuff while air is put into or out of the system. Moreover, the blood pressure monitor must be able to perform many other functions, such as:

- Display information
- Provide audio feedback
- Keep statistical records
- Using USB or ZigBee communications, send statistical feedback to a PC for further analysis

4.2 Software Design Goals

The software design pursues these goals:

- Modularity — The software must be completely modular and with as little cohesion as possible. This modularity should be reflected in ease of making changes, if adding new functionalities and modules, or if modifying existing ones.
- Interoperability — Modules must not have any blocking functions. This makes it possible to allow other modules to be kept up-to-date.

4.3 Software Architecture

The software architecture on the blood pressure monitor was designed in this way: application software can be found on the main.c file; from here, the main() routine can call different services and hardware features. Services will have direct contact with hardware on the MCU. The hardware has a hardware abstraction layer that eases migration to another MCU. The real time clock (RTC) can be seen as a complex driver which can service other functions, and is used as the system clock. All modules that depend on time-triggered functions take their time base from the RTC.

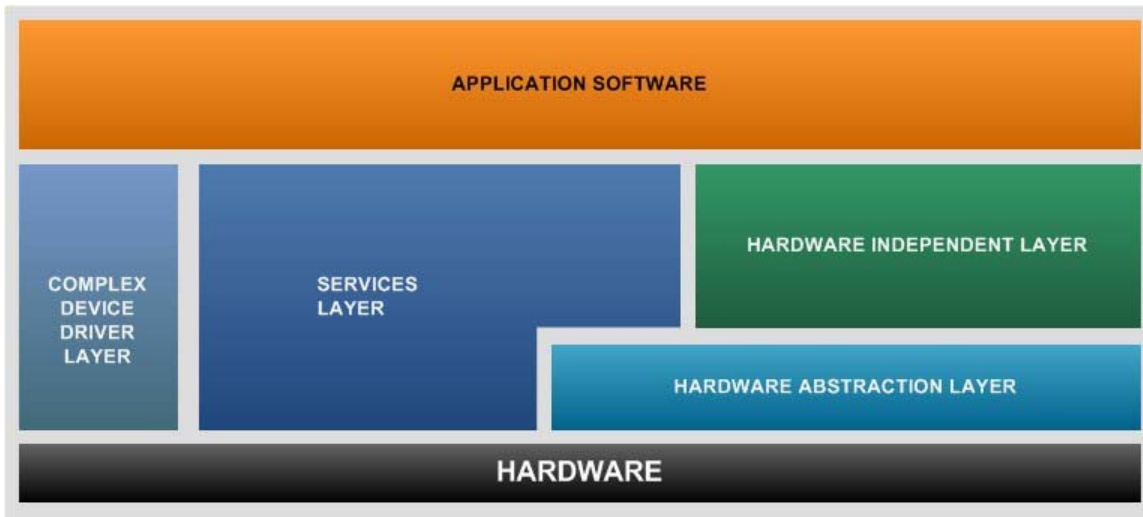

The fact that each module has its own .c file simplifies the process of adding and eliminating modules in the code.

4.4 Software

4.4.1 Blood Pressure Measurement

The blood pressure measurement is part of the hardware independent layer of the application. This module is set up to work as a state machine that is called from the main loop. When a measurement is not being taken, the system is in an IDLE state — when a measurement starts, the state machine is changed. It then enables the pressure sensor, RTC, and TPM modules. Next, the system begins to inflate the cuff according to the necessary measurement. Whenever a measurement is being taken, the RTC takes an ADC measurement of the cuff pressure and of the high pass filter every 1 ms. This measurement is what is used by the blood pressure state machine to adjust the level of inflation by controlling the motors, using a TPM module in the MCU. After the measurement finishes, the system disables all unused modules and goes back to the IDLE state.

4.4.2 Capacitive Touch

The sensor is controlled using a state machine which runs in the application’s main loop. It is called periodically and is non-blocking. This state machine uses the hardware abstraction layers that manage the IIC and KBI modules of the microcontroller. This figure shows the state machine being used:

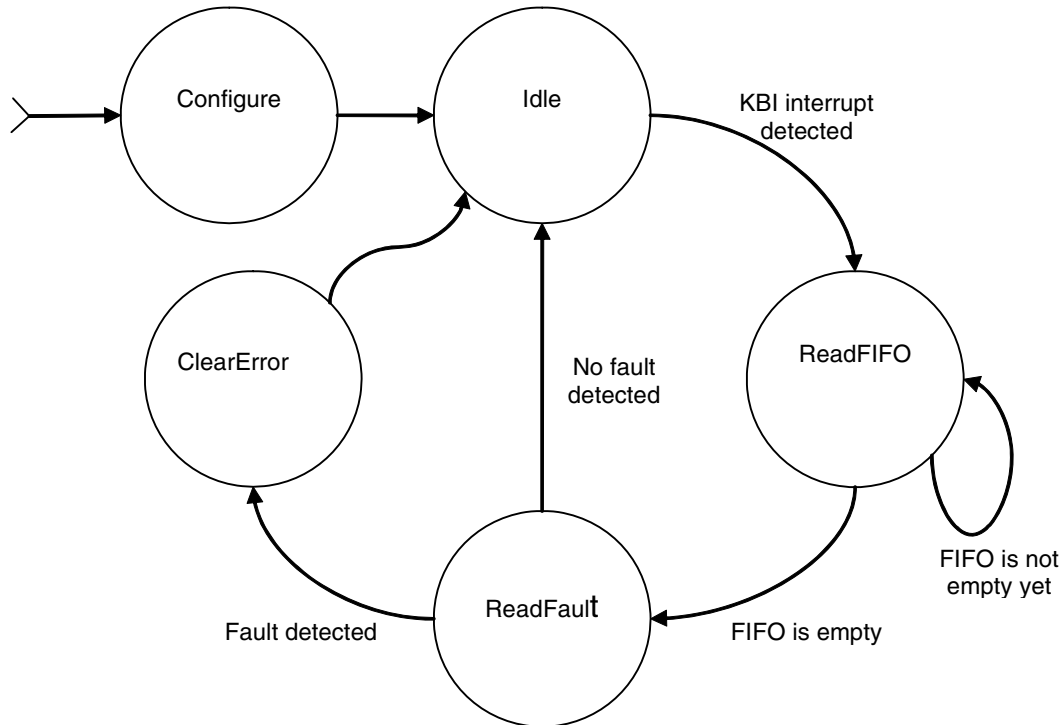

Initially, the MPR083 is configured to work with interrupts, so the IRQ output of the sensor can wake the MCU when needed (using a KBI pin). After the configuration has been written the state machine enters an idle state, during which it checks for a KBI interrupt, generated by a touch event in the sensor.

After a touch is detected, the state machine starts reading the FIFO register in the MPR083. Because the FIFO register can store up to 30 touch-event values, it is read until it empties, and the last value is the one used. The value of the electrode pressed is stored in a global variable and another variable is used to know if the key was pressed or released.

The fault register in the sensor is used to determine if one or more electrodes were shorted to V_{DD} or V_{SS} . After a fault is asserted, the sensor electrodes will no longer be scanned until the fault is cleared.

That is why after reading the FIFO register, the program reads the fault register, checking for errors. If no error is detected, the state machine enters the idle state again. Otherwise, if a fault is detected, the state machine goes to an error-clearing state. This is the procedure used to clear the fault:

1. Stop the electrode scanning by writing the configuration register (stop mode).
2. Clear the fault condition by writing the fault register.
3. Start the electrode scanning again by writing the configuration register (run mode).

After these steps are done, the state machine enters the idle state again, checking for any other electrode touch event.

4.4.3 MRAM Storage

The system uses MRAM to store data. To do this, the MCU dedicates eight complete ports for MRAM use. The MRAM is part of the hardware independent layer and is used by the voice generator module to read raw audio to reproduce. The MRAM is also used by the blood pressure monitor to store the last five readings.

4.4.4 OLED Display

The OLED display driver was taken directly from application note AN3415. In this application note, all the necessary steps are taken to enable, initialize, and use the OLED display.

The system uses an SPI port to send commands and data to the OLED display. The system also controls the 12 V power source that powers up the display and can therefore save power by powering down the OLED display. The main modification implemented to this driver was a 200 ms delay between each display refresh. This delay was added using a counter incremented by the RTC interrupt. The main state machine for the demo dictates which screen to display and which language to use.

4.4.5 USB Communication

USB communication is done using a HC9S08JM60 that acts as a bridge between the PC and the Flexis microcontroller. The communication to the HC9S08JM60 is done through an SCI port. All data requests are initiated by the PC and relayed by the HC9S08JM60. Whenever the Flexis device receives a new request through an SCI interrupt, it checks to see if USB communication is enabled, and if so, it will return the requested data back through the SCI.

The program implemented on the HCS08JM60 is a simple application: the MCU waits to receive data through the USB or SCI ports, then places that data into the other bus.

4.4.6 Voice Generation

All voice commands are initiated by the OLED state machine, and are further updated through interrupts when the sampling timer overflows. Voice generation is done using two TPM modules: one channel is used to set the sample rate of the audio, and the other channel is used to create a PWM frequency. This PWM frequency is then passed through the audio filter, where it becomes a fixed amplitude which is sent to the speaker. The frequency is repeated over and over until a new sample is taken from an audio file, then this new sample value is placed in the fast frequency. The timing for these signals appears like this:

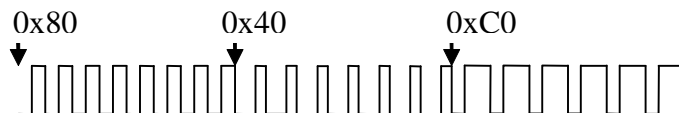

The arrows indicate each time there is a sampling interrupt. At that moment, the system reads the audio file to set the PWM frequency for the audio generation. This PWM frequency will remain in effect until the next sampling interrupt. This process continues until the end of the audio file has been reached. At that point, the system stops the PWM generation.

To generate the audio, the system uses files stored in the MRAM. These are raw audio files using an 8-bit sample size with an 8 kHz sampling rate. This sampling rate provides audio with about the same quality as a telephone. It is important to note that this process can be done at a much higher sampling rate that will generate full audio. The only change required is for the system to have enough memory to be able to store the larger audio files.

4.4.7 ZigBee Communication

ZigBee communication on the blood pressure monitor is done through an SPI interface to the MC13202 and six separate I/O ports, including the IRQ pin. The IRQ pin signals when the transceiver has information that it needs to send to the MCU. The transmission of measured data through ZigBee is done within the OLED state machine whenever the system is displaying measured data. The state machine will check to see if ZigBee communication is enabled — if so, it will then place the systolic pressure in the ZigBee transmission buffer, send that buffer through the SPI to the transceiver, then ask the transceiver to transmit the buffer. This procedure is then repeated for the diastolic pressure and pulse rate that were taken at the same time. Due to the fact that all ZigBee communications are initiated by the blood pressure monitor, whenever the system is not sending messages the transceiver is disabled, as well as all peripherals related to the transceiver for the MCU.

Chapter 5

Customizing the Blood Pressure Monitor

You can use any part(s) of the blood pressure monitor to suit your application needs. For example, if you wish to communicate an application with an MRAM, only add the MRAM.h file into the code, and declare the address and data ports as well as the control bits.

Likewise, the OLED display can also be taken and added into any application. The OLED.c file contains all the necessary functions to use the OLED display. If you wish to use the OLED display in another application, add the OLED.h file into the code, change the pin declarations of the SPI, the OLED reset pin, the 12 V enable pin, and the data/command pin.

Appendix A Schematics

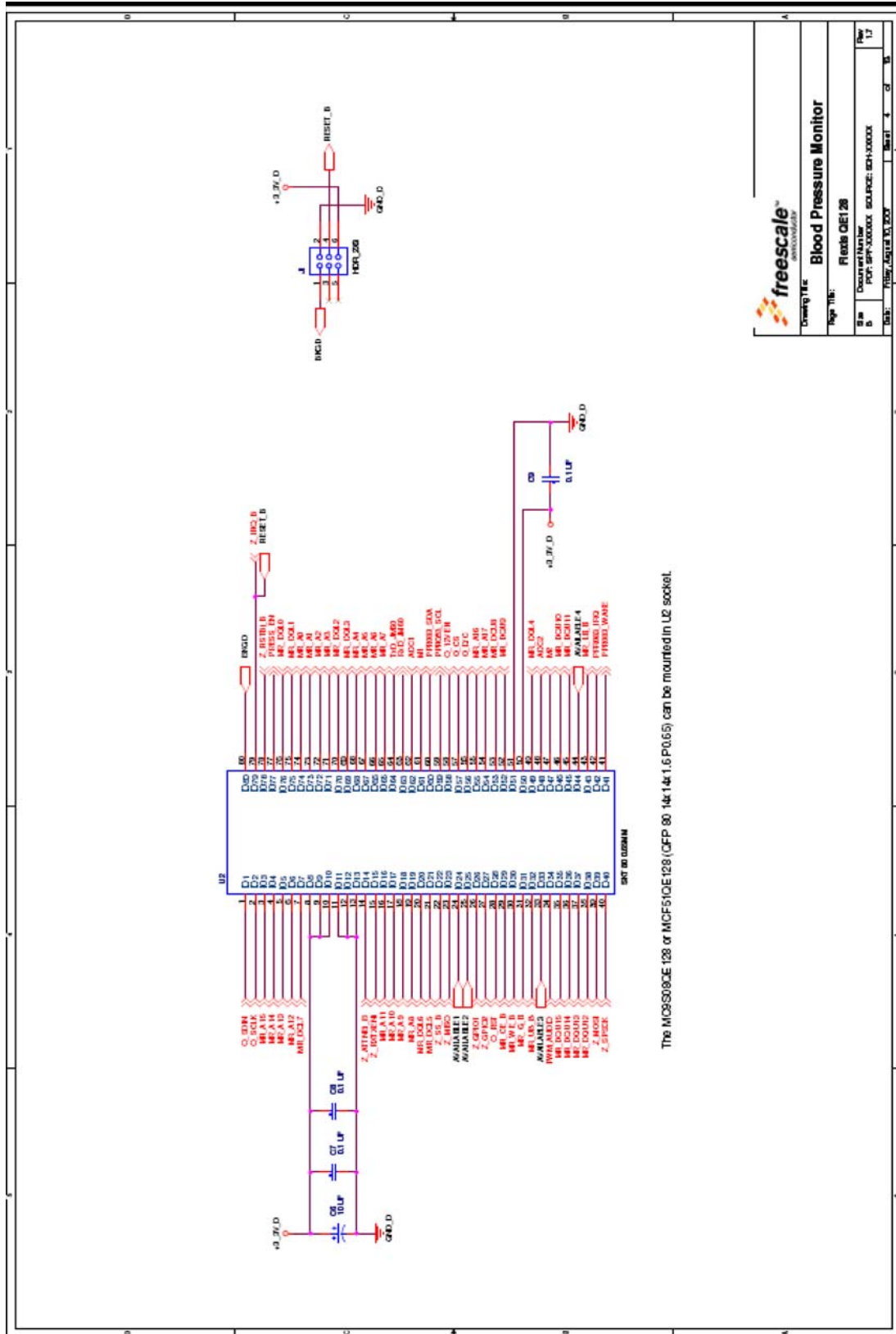

The MCP9802E 128 or MCP5102E 128 (GFP 80 14r14r1.6 P0.65) can be mounted in LC socket.

freescale
SEMICONDUCTOR

Doc ID: 44117

Page Title: Blood Pressure Monitor

Page No: 17

Doc Number: MCP9802E 128

Doc Source: SCH-XXXXX

Doc Date: 10/12/07

Doc Rev: 1

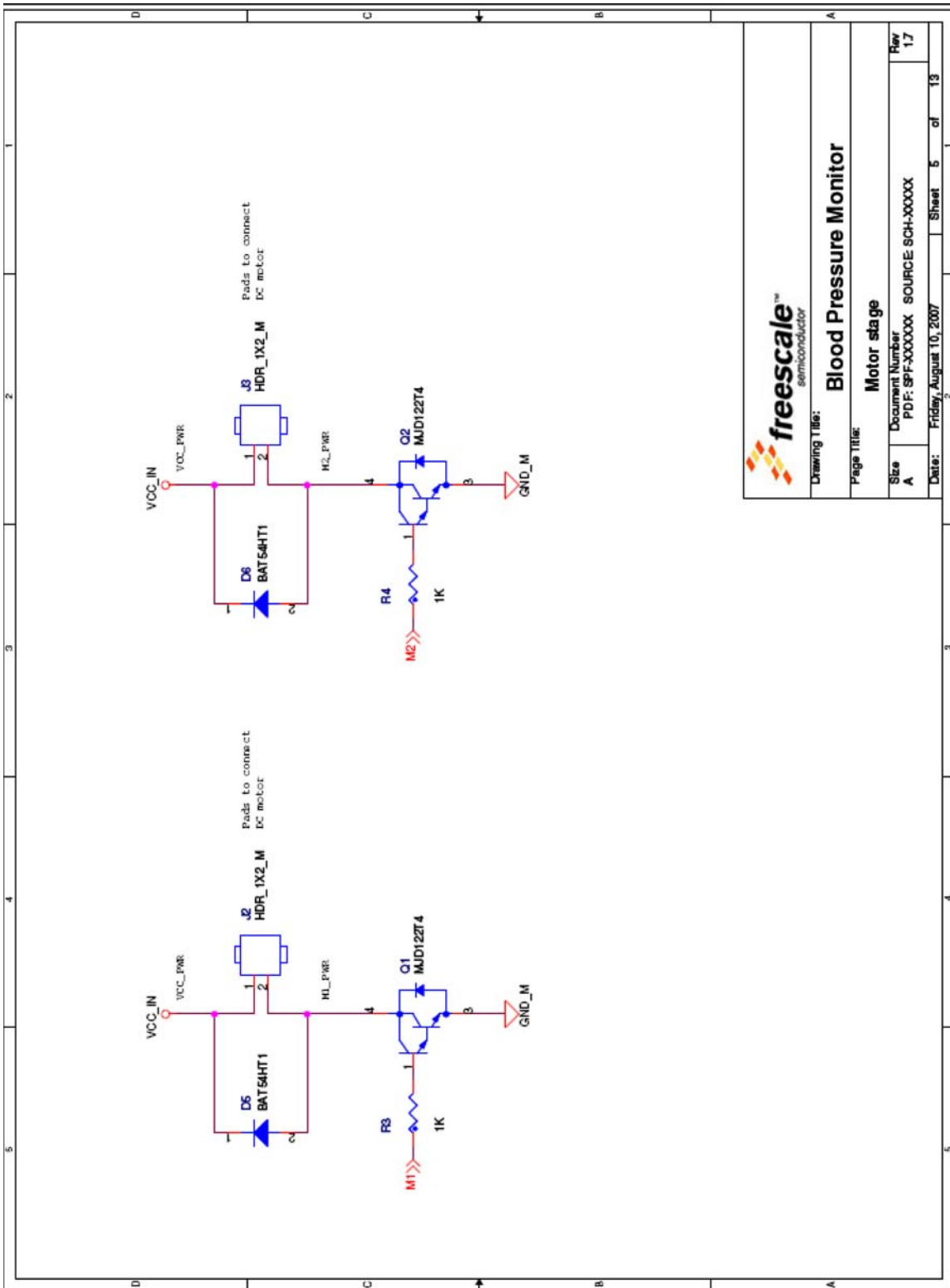

Drawing Title:
Blood Pressure Monitor

Page Title:
Motor stage

Size: A
Document Number: PDF: SPF-XXXXXX SOURCE: SCH-XXXXX
Rev: 1.7

Date: Friday, August 10, 2007
Sheet: 5 of 13

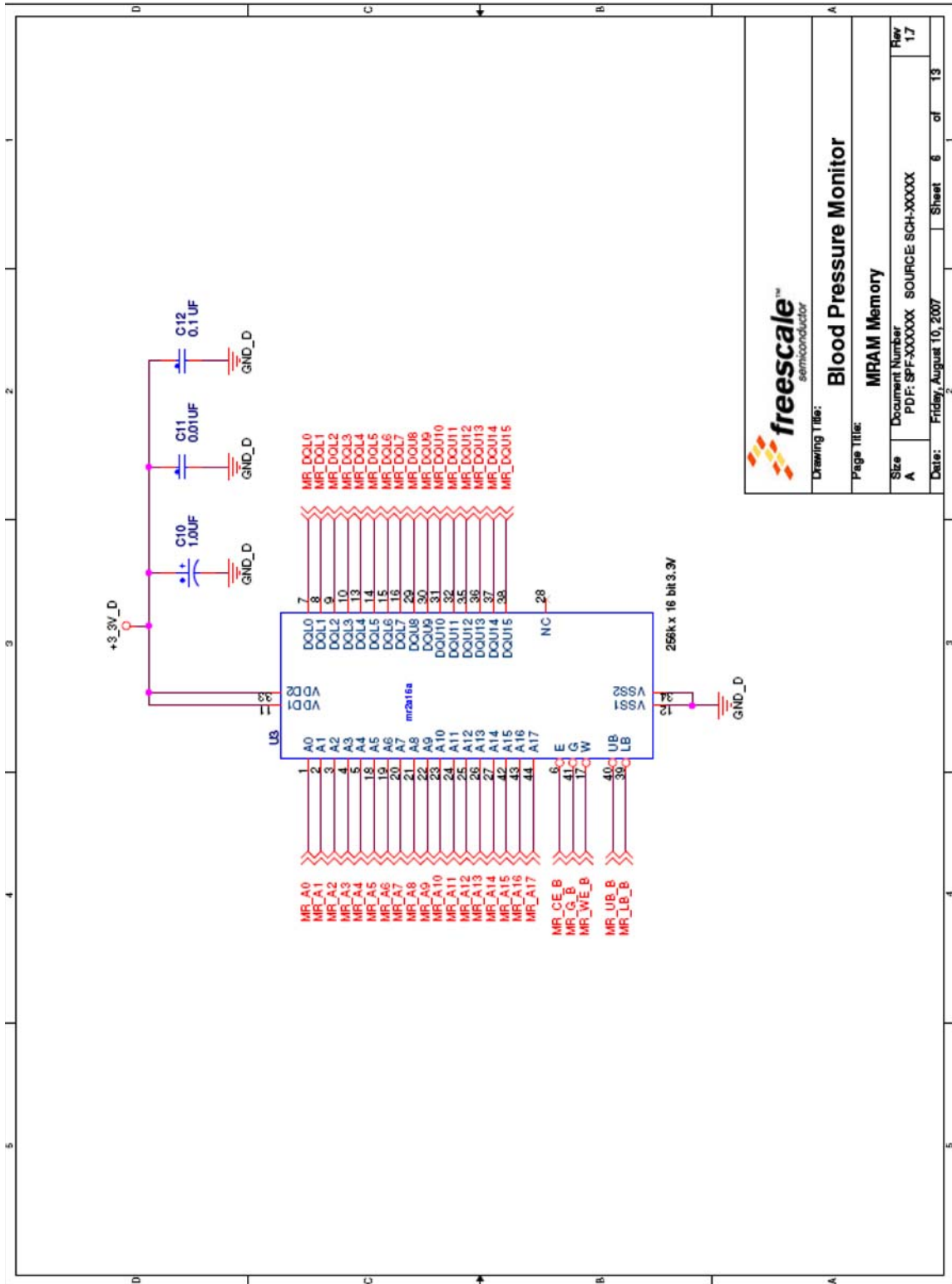

freescale
semiconductor

Drawing Title: **Blood Pressure Monitor**

Page Title: **MRAM Memory**

Size: A

Document Number: PDF: SPF-XXXXXX SOURCE SCH-XXXXX

Rev: 1.7

Date: Friday, August 10, 2007

Sheet 6 of 13

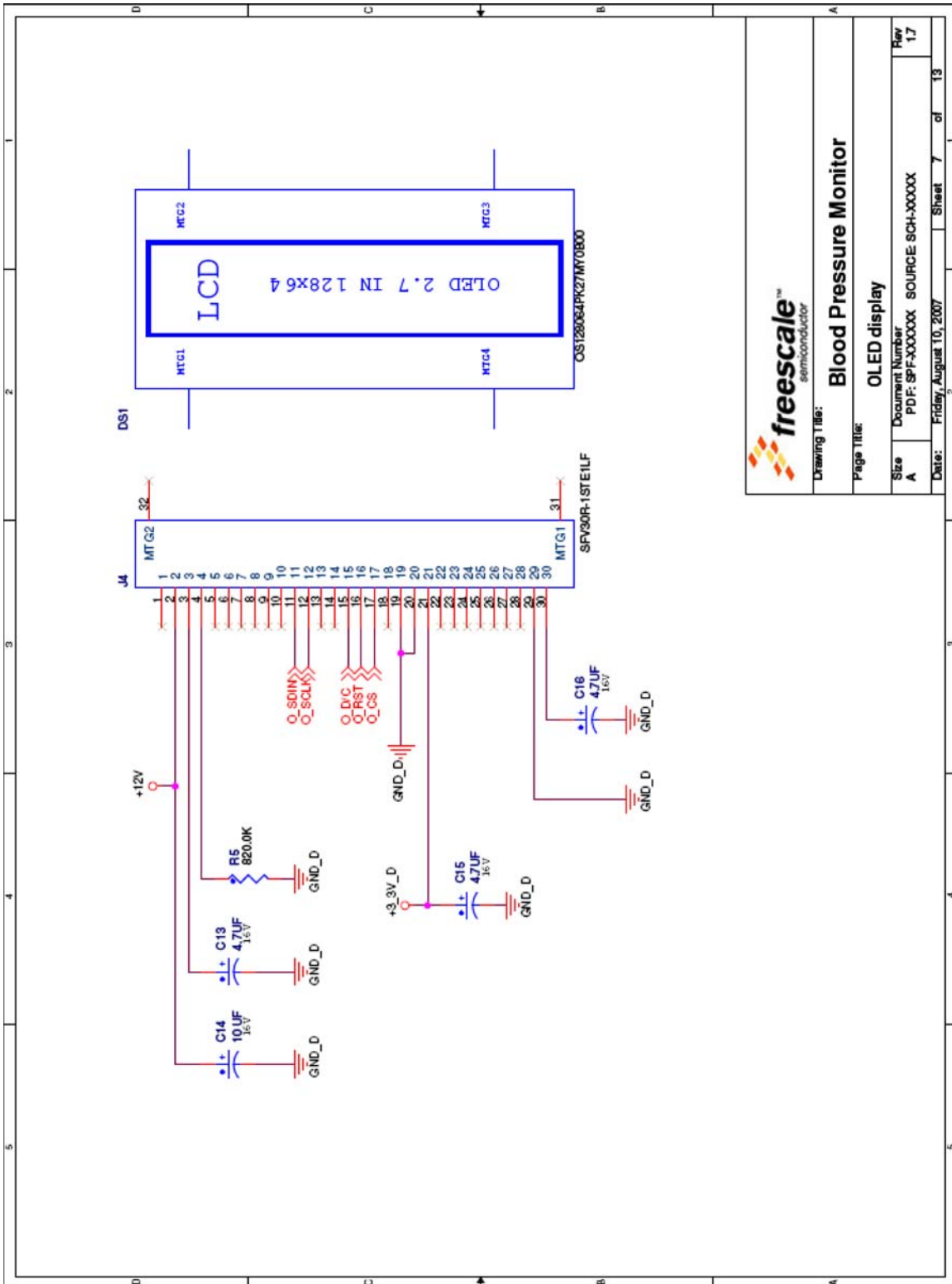

Drawing Title: **Blood Pressure Monitor**

Page Title: **OLED display**

Size A	Document Number: PDF: SPF-XXXXXX SOURCE SCH-XXXXX	Page 17
Date: Friday, August 10, 2007	Sheet 7 of 13	

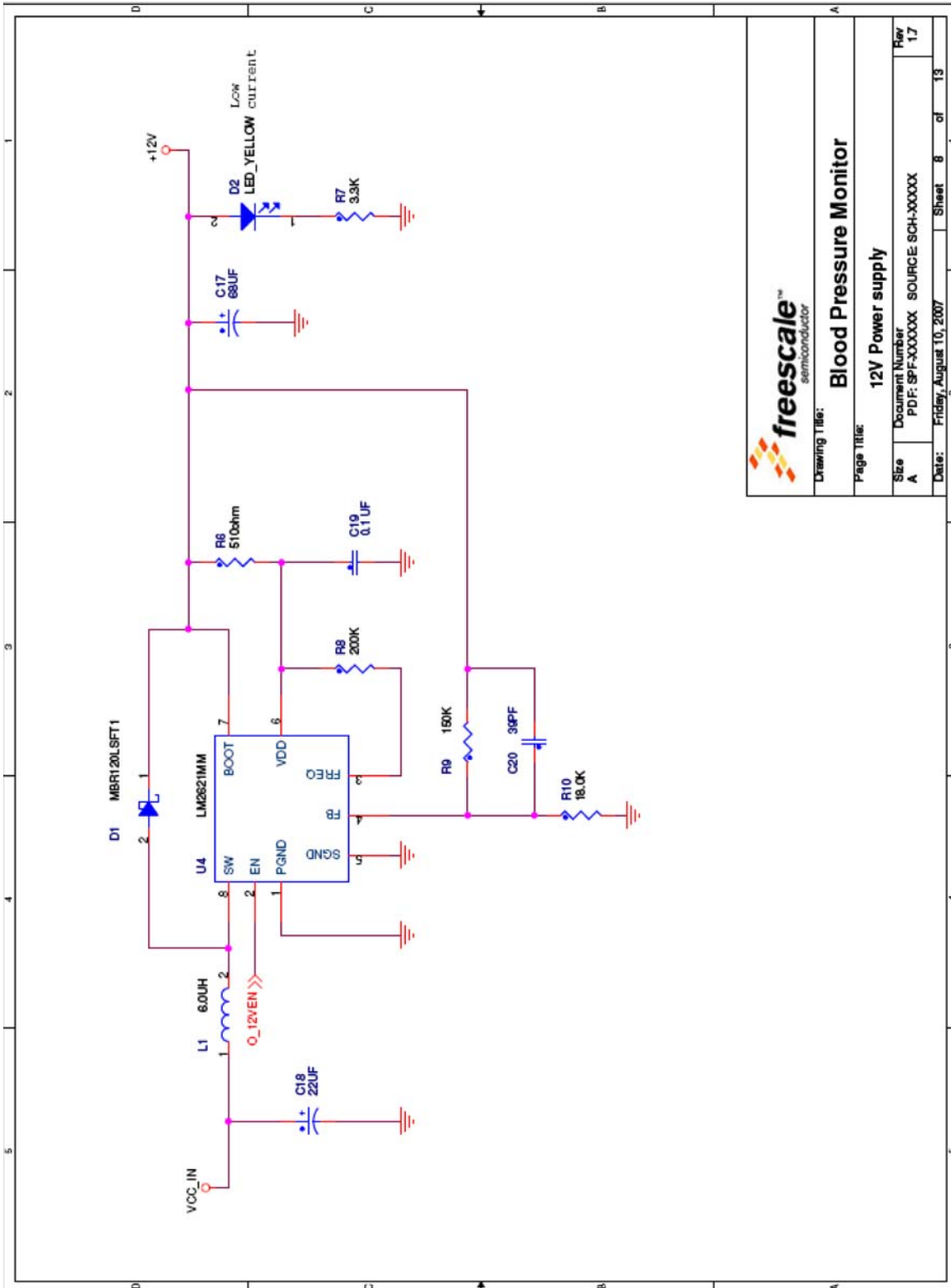

Drawing Title: **Blood Pressure Monitor**

Page Title: **12V Power supply**

Size A Document Number PDF: SPF-XXXXXX SOURCE: SCH-XXXXX Rev 1.7

Date: Friday, August 10, 2007 Sheet 8 of 13

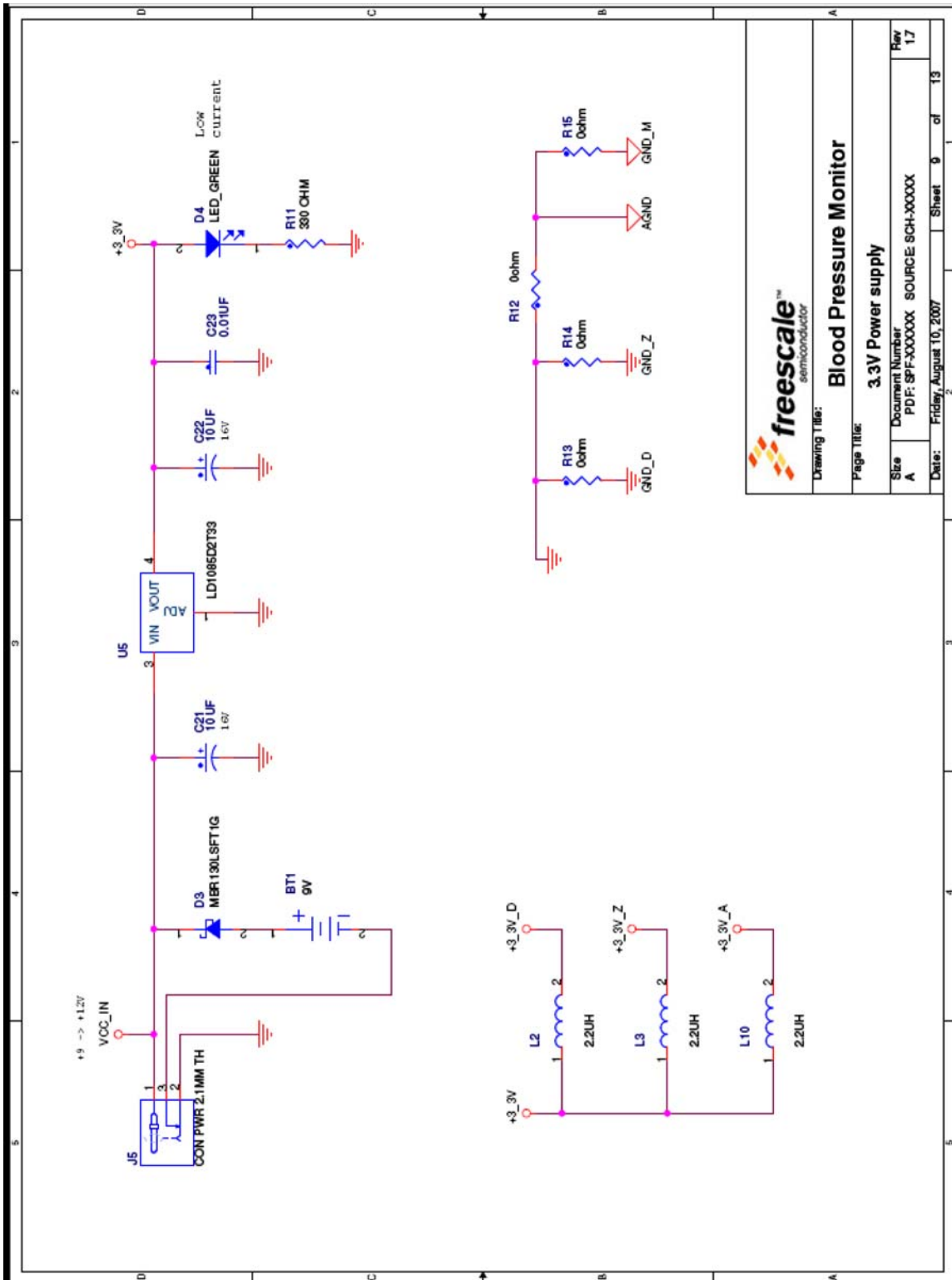

Drawing Title: **Blood Pressure Monitor**

Page Title: **3.3V Power supply**

Size	Document Number	Rev
A	PDF: 8PFXXXXXX SOURCE SCH:XXXXX	1.7

Date: Friday, August 10, 2007 Sheet 9 of 13

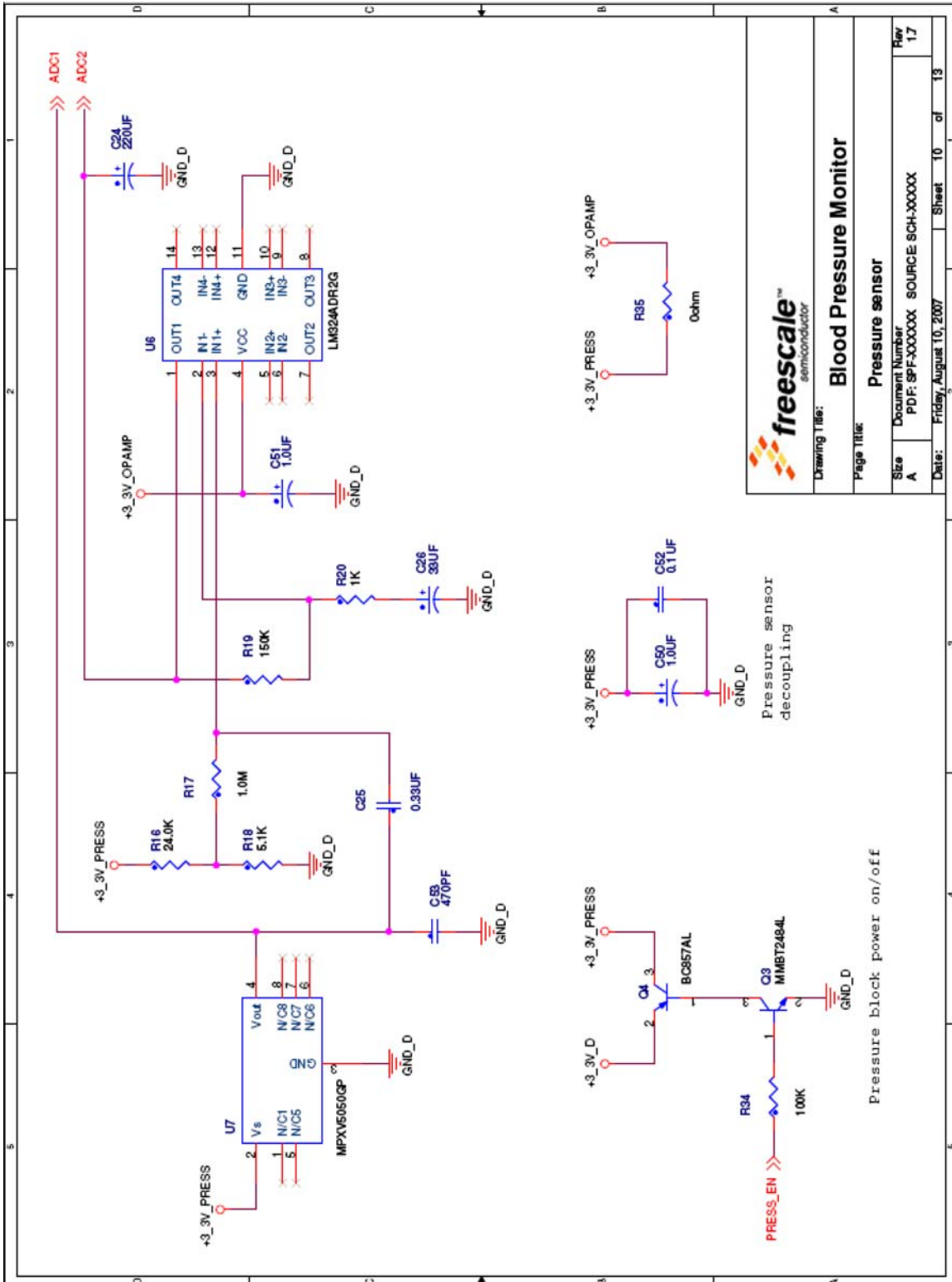

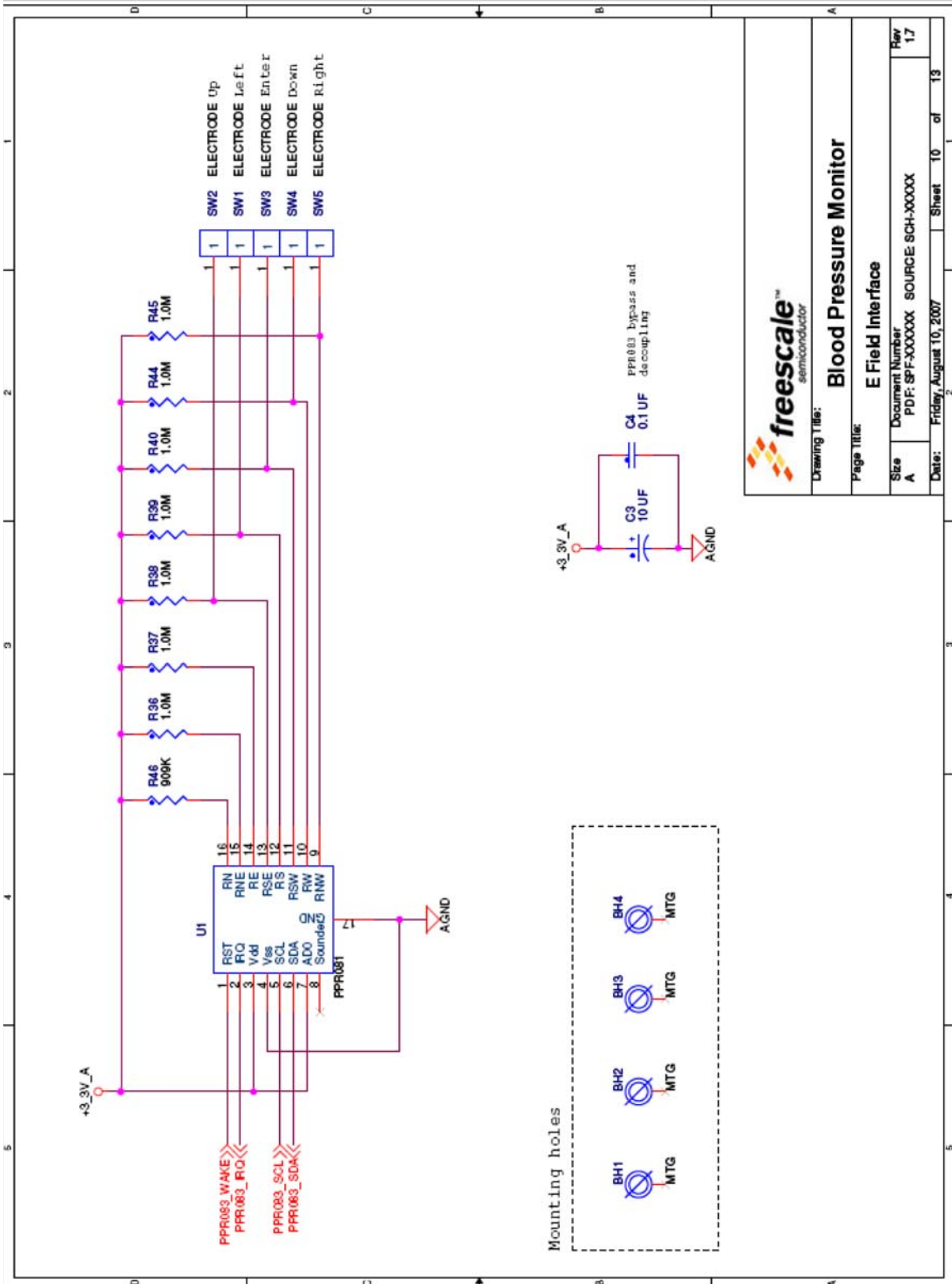

freescale™
semiconductor

Blood Pressure Monitor

E Field Interface

Document Number: PDF: SPF-XXXXX SOURCE: SCH-XXXXX Rev: 1.7

Date: Friday, August 10, 2007 Sheet 10 of 13

Blood Pressure Monitor Design Reference Manual, Rev. 0

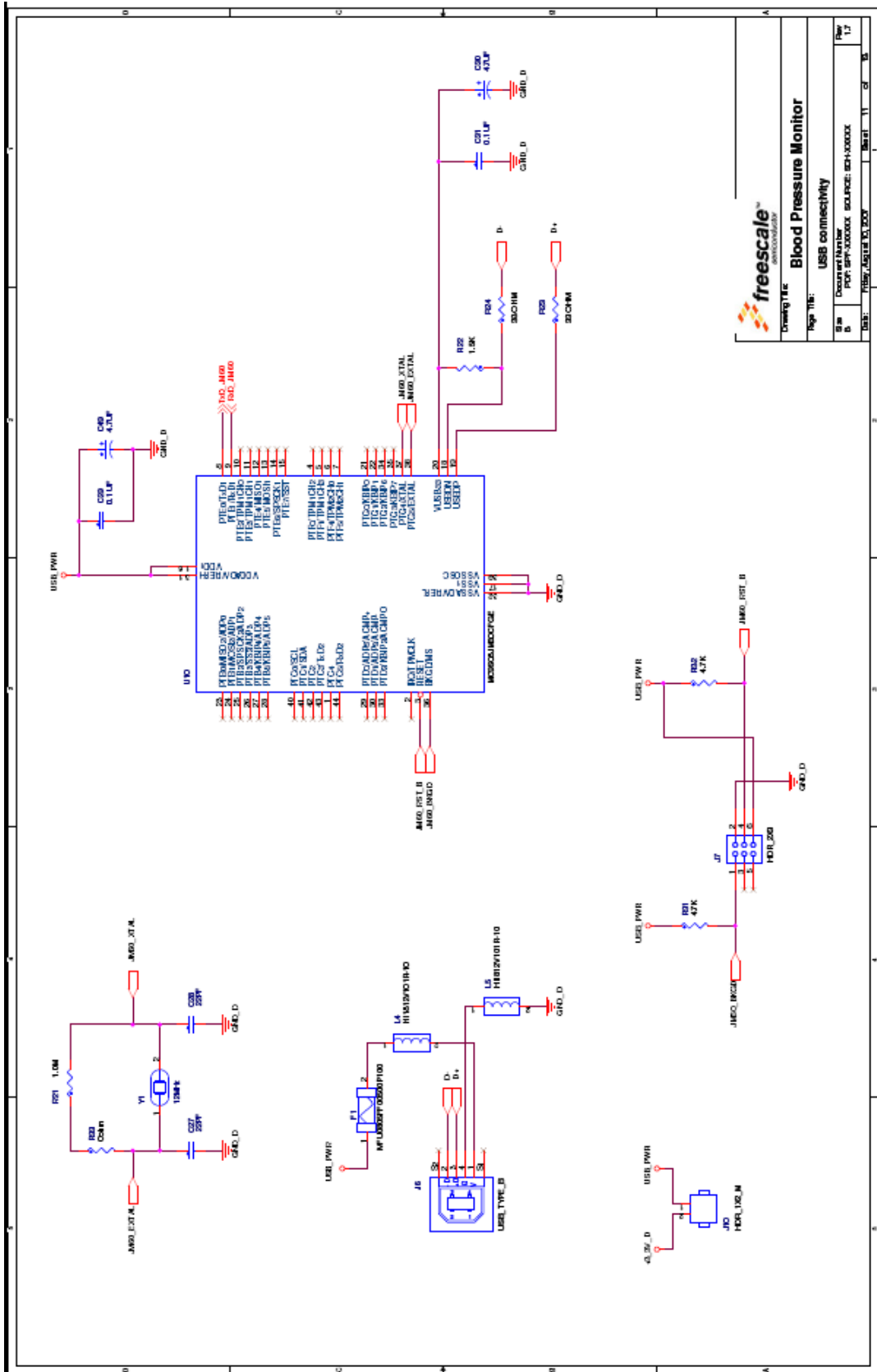

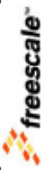
 **freyscale**
SEMICONDUCTOR

Creating The
Blood Pressure Monitor

Page Title: USB connectivity
Doc Number: 17-00000
Part Number: 93M01000X
Source: 93M01000X
Rev: 1.0

Blood Pressure Monitor Design Reference Manual, Rev. 0

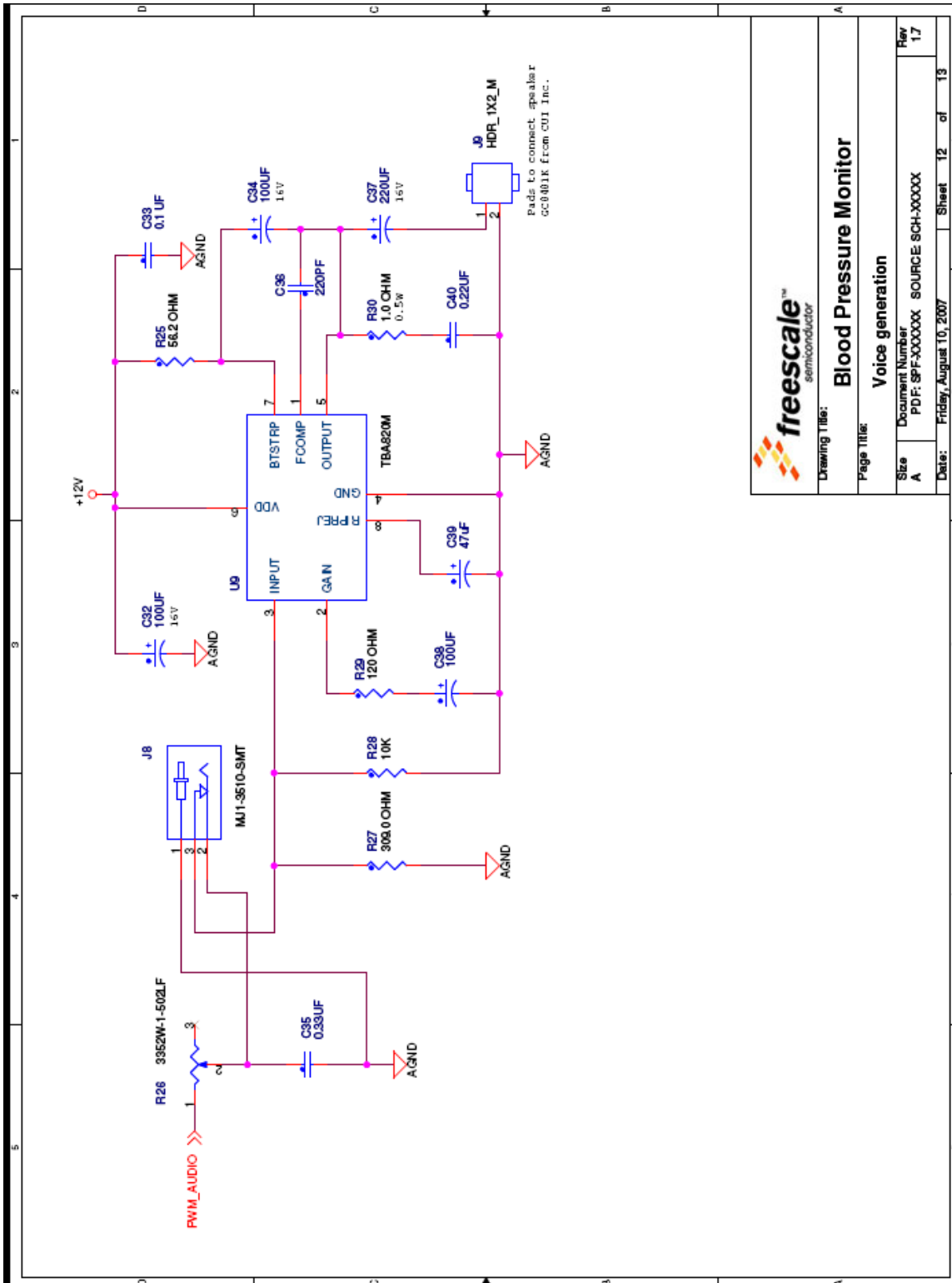

Drawing Title:		Blood Pressure Monitor	
Page Title:		Voice generation	
Size	Document Number	Rev	
A	PDF: SPF-XXXXXX SOURCE: SCH-XXXXX	17	
Date:	Friday, August 10, 2007	Sheet	12 of 13

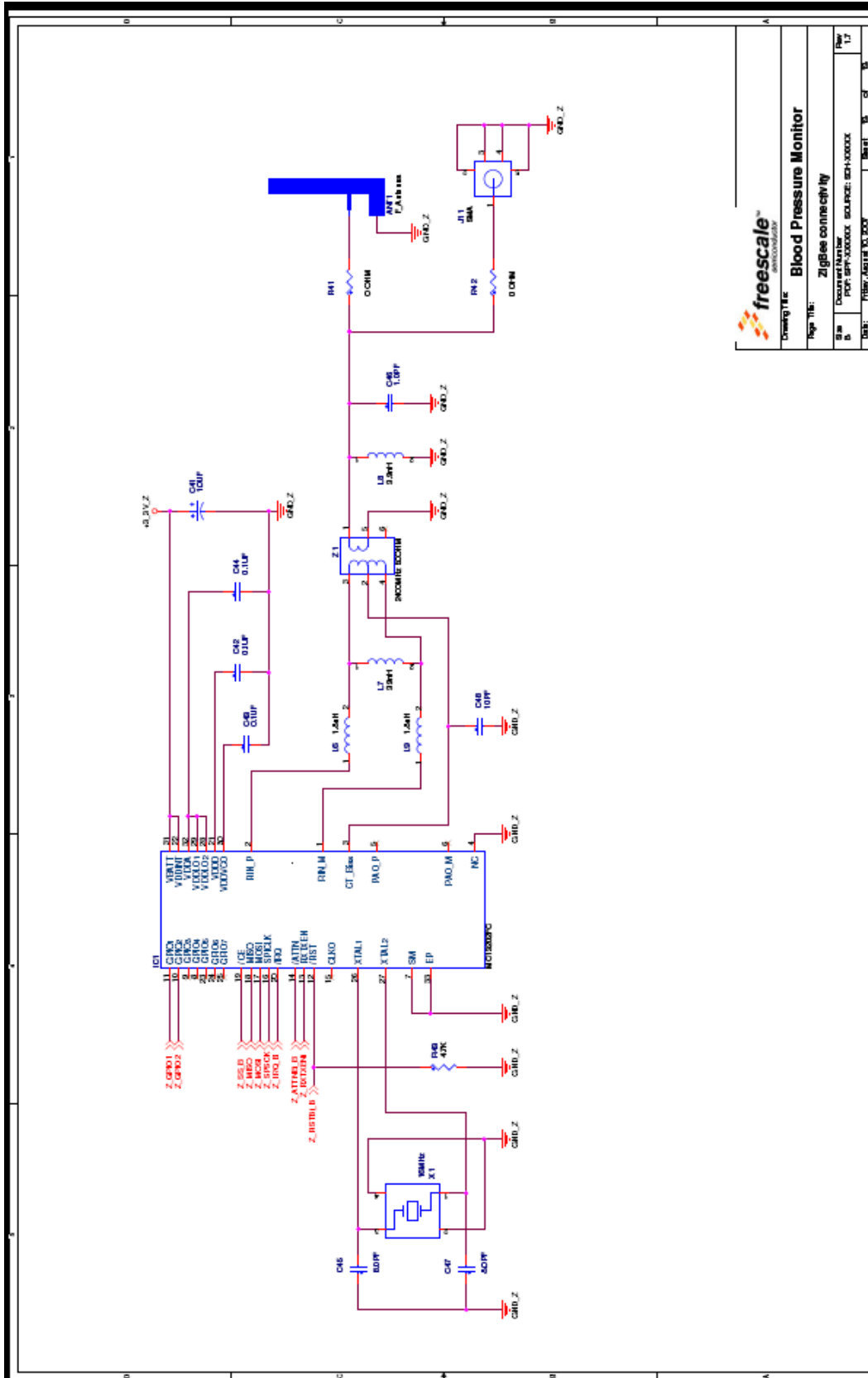

freescale
SEMICONDUCTOR

Doc ID: 4411 **Blood Pressure Monitor**

App. No.: ZigBee connectivity

Doc. No.: MCF8020C_BPM_ZIGBEE

Rev. 1.1

Date: 10/27/2009

Appendix B

Bill of Materials

QTY	Reference Designator	Value	Package	Description	Type
1	ANT1	F_Antenna	f_antenna	PCB F Antenna for ZigBee	PCB
4	BH1, BH2, BH3, BH4	MTG	C280-130T	Mounting Hole 0.130 Inch	Oth
1	BT1	9 V	skt_bat_54x29mm_th	Holder Batt 9 V Univ Plastic PC	Oth
5	C3, C6, C14, C21, C22	10 μ F	CC3216	Cap Tant 10 μ F 16 V 20% SMD	Cap
10	C4, C7, C8, C9, C12, C19, C29, C31, C33, C52	0.1 μ F	CC0805	Cap 0.1 μ F 16 V Ceramic X7R 0805	Cap
4	C10, C41, C50, C51	1.0 μ F	3216-18	Capacitor Tant 1.0 μ F 16 V 20% SMD	Cap
2	C11, C23	0.01 μ F	CC0805	Cap 10000 pF 50 V Ceramic Chip 0805	Cap
3	C13, C15, C16	4.7 μ F	CC3216	Cap Tant 4.7 μ F 16 V 20% SMD	Cap
1	C17	68 μ F	CC7343-43	Cap Tant 68 μ F 16 V 10% Loesr SMD	Cap
1	C18	22 μ F	CC3216	Cap Tant 22 μ F 16 V 20% SMD	Cap
1	C20	39 pF	CC0805	Cap 39 pF 50 V Ceramic Chip 0805 SMD	Cap
2	C24, C37	220 μ F	cce63x55	Cap 220 μ F 16 V Elect MVE SMD	Cap
2	C25, C35	0.33 μ F	CC0805	Cap 0.33 μ F 16 V Ceramic X7R 0805	Cap
1	C26	33 μ F	CC3216	Cap Tant 33 μ F 6.3 V 20% SMD	Cap
2	C27, C28	22 pF	CC0805	Cap 22 pF 50 V Ceramic Chip 0805 SMD	Cap
2	C30, C49	4.7 μ F	CC2012-12	Cap Tant 4.7 μ F 10 V 20% SMD	Cap
3	C32, C34, C38	100 μ F	cce63x55	Cap 100 μ F 16 V Elect MVA SMD	Cap

Bill of Materials

QTY	Reference Designator	Value	Package	Description	Type
1	C36	220 pF	CC0805	Cap Ceramic 220 pF 50 V NPO 0805	Cap
1	C39	47 μ F	CCE63X57	Cap 47 μ F 16 V Elect MVE SMD	Cap
1	C40	0.22 μ F	CC0805	Cap Ceramic .22 μ F 50 V X7R 0805	Cap
3	C42, C43, C44	0.1 μ F	CC0603	Cap 0.1 μ F 50 V Ceramic Y5V 0603	Cap
2	C45, C47	8.0 pF	CC0603	Cap 8.0 pF 50 V Ceramic 0603 SMD	Cap
1	C46	1.0 pF	CC0402_25	Cap 1.0 pF 50 V Ceramic 0402 SMD	Cap
1	C48	10 pF	CC0402_25	Cap 10 pF 50 V Ceramic 0402 SMD	Cap
1	C53	470 pF	CC0603	Cap Ceramic 470 pF 50 V X7R 10% 0603	Cap
1	DS1	OS128064PK27MY0B00	os12806_4_th	Display OLED 128 X 64 2.7 Inch Yellow	Oth
1	D1	MBR120LSFT1	SOD-123	Diode Schottky 40 V 1 A SOD123	SC
1	D2	Yellow	LED_0603_C1	LED Amber SS Type Low Cur SMD	SC
1	D3	MBR130LSFT1G	SOD-123	Diode Schottky 30 V 1 A SOD123	SC
1	D4	Green	LED_0603_C1	LED Green SS Type Low Cur SMD	SC
2	D5, D6	BAT54HT1	SOD323	Diode Switch SW 75 V 500 mA SOT323	SC
1	F1	MFU0805FF00500P100	fuse_2x1p4	Fuse 0.50 A 0805 VFast SMD	Oth
1	IC1	MC13202FC	qfn32_5x5	IC TXRX RF 2.4 GHz 32-QFN	IC
2	J1, J7	HDR_2X3	HDR203	Conn Header 6 Pos 0.100 Inch Str Gold	Con
4	J2, J3, J9, J10	HDR_1X2_M	HDR102	Conn Header 2 Pos 0.100 Inch Str Tin	Con
1	J4	SFV30R-1STE1LF	con_30_sm_ra	Conn FPC/FFC 30 Pos .5 mm R/A SMD	Con
1	J5	CON PWR 2.1MM TH	PJ-202B	Conn Pwr Jack 2.1 X 5.5 mm High Cur	Con
1	J6	USB_TYPE_B	CON_USB_RA	Conn USB Rt Ang Recept Type B	Con

QTY	Reference Designator	Value	Package	Description	Type
1	J8	MJ1-3510-SMT	con3_jack_5x15_sm	Conn Jack Mono 3 Pos 3.5 mm SMD	Con
1	J11	SMA	CON_SMA_8363	Conn Sma Jack Straight PCB	Con
1	L1	6.0 μ H	IND_CDRH6D28	Power Inductor 6.0 μ H 2.25 A SMD	Ind
3	L2, L3, L10	2.2 μ H	ind_2016	Inductor 2.2 μ H 20% 0806 SMD	Ind
2	L4, L5	HI1812V101R-10	IND_ISC_1812	Ferrite 8 A 125 Ω 1812 SMD	Ind
2	L6, L9	1.8 nH	ind_0402	Inductor Hi Freq 1.8 \pm 0.3 nH 0402	Ind
2	L7, L8	3.9 nH	IND_0402	Inductor Hi Freq 3.9 \pm 0.3 nH	Ind
2	Q1, Q2	MJD122T4	DPAK	Trans Darl NPN 100 V 5 A DPAK	SC
1	Q3	MMBT2484L	SOT23	Trans GP SS NPN 30 V LN SOT23	SC
1	Q4	BC857AL	SOT23	Trans GP SS PNP LN 50 V SOT23	SC
3	R3, R4, R20	1 k	RC0805	Res 1.00 k Ω 1/8 W 1% 0805 SMD	Res
1	R5	820.0 k	RC0805	Res 820 k Ω 1/8 W 1% 0805 SMD	Res
1	R6	510 Ω	RC1206	Res 510 Ω 1/4 W 1% 1206 SMD	Res
1	R7	3.3 k	RC0805	Res 3.30 K Ω 1/8 W 1% 0805 SMD	Res
1	R8	200 k	RC0805	Res 200 k Ω 1/8 W 1% 0805 SMD	Res
2	R9, R19	150 k	RC0805	Res 150 k Ω 1/8 W 1% 0805 SMD	Res
1	R10	18.0 k	RC0805	Res 18.0 k Ω 1/8 W 1% 0805 SMD	Res
1	R11	330 Ω	RC0805	Res 330 Ω 1/8 W 1% 0805 SMD	Res
6	R12, R13, R14, R15, R33, R35	0 Ω	RC0805	Res 0.0 Ω 1/8 W 5% 0805 SMD	Res
1	R16	24.0 k	RC0805	Res 24.0 k Ω 1/8 W 1% 0805 SMD	Res
2	R17, R21	1.0 M	RC0805	Res 1.00 M Ω 1/8 W 1% 0805 SMD	Res

Bill of Materials

QTY	Reference Designator	Value	Package	Description	Type
1	R18	5.1 k	RC0805	Res 5.10 k Ω 1/8 W 1% 0805 SMD	Res
1	R22	1.5 k	RC0805	Res 1.50 k Ω 1/8 W 1% 0805 SMD	Res
2	R23, R24	33 Ω	RC0603	Res 33.0 Ω 1/10 W 1% 0603 SMD	Res
1	R25	56.2 Ω	RC0805	Res 56.2 Ω 1/8 W 1% 0805 SMD	Res
1	R26	5.0 k	pot3_3296y	Pot 5.0 k Ω Thumbwheel Ceramic ST	Res
1	R27	309.0 Ω	RC0805	Res 309 Ω 1/8 W 1% 0805 SMD	Res
1	R28	10 k	RC0805	Res 10.0 k Ω 1/8 W 1% 0805 SMD	Res
1	R29	120 Ω	RC0805	Res 120 Ω 1/8 W 1% 0805 SMD	Res
1	R30	1.0 Ω	RC1210	Res Anti-Surge 1.0 Ω 5% 1210	Res
3	R31, R32, R43	4.7 k	RC0805	Res 4.70 k Ω 1/8 W 1% 0805 SMD	Res
1	R34	100 k	RC0805	Res 100 k Ω 1/8 W 1% 0805 SMD	Res
7	R36, R37, R38, R39, R40, R44, R45	1.0 M	RC0603	Res 1.00 M Ω 1/10 W 1% 0603 SMD	Res
1	R41, R42	0 Ω	RC0603	Res 0.0 Ω 1/10 W 5% 0603 SMD	Res
1	R46	909 k	RC0603	Res 909 k Ω 1/10 W 1% 0603 SMD	Res
5	SW1, SW2, SW3, SW4, SW5	Electrode	e_button	Electrode Square 1 cm	Bttn
1	U1	PPR081	qfn16_8mm		IC
1	U2	QFP SOCKET80_0.65MM	QFP80_PSOC_65MM_EN P	Con 80 Skt Th 0.65 mm Sp Au	Con
1	U2	MC9S08QE128CLK	qfp80_sq	IC MCU 8-Bit 3.3–5 V LQFP80	IC
1	U2	MCF51QE128CLK	qfp80_sq	IC MCU 32-Bit 3.3–5 V LQFP80	IC
1	U3	25 6k x 16-bit 3.3 V	tsop44_t2	IC Mem MRAM 256 K X 16 35 nS Async 3.3 V TSSOP44	IC

QTY	Reference Designator	Value	Package	Description	Type
1	U4	LM2621MM	so8_umax	IC Low Input Step-Up DC-DC8-MSOP	IC
1	U5	LD1085D2T33	d2pak	IC LDO Positive Reg 3.3 V D2PAK	IC
1	U6	LM324ADR2G	soic14	IC Opamp Quad Low Power 14SOIC	IC
1	U7	MPXV5050GP	8PINS_2p54_SM	IC Press Sensor 0–50 kPa 5 V Case 1369-01	IC
1	U9	TBA820M	pdip8_300	IC Audio Amp 1.2 W 8-Dip	IC
1	U10	MC9S08JM60CFGE	tqfp44	IC MCU 8-Bit 60K Flash 2.7–5.5V LQFP44	IC
1	X1	16 MHz	xtal3_2x2_5mm_4p	Crystal 16.000000 MHz SMD 8 pF	Xtal
1	Y1	12 MHz	XTL2_HCM49	Crystal 12.000 MHz 18 pF Fund SMD	Xtal
1	Z1	2400 MHz 50 Ω	XFMR_HHM1525_2x1_25mm_6P	Cer Microwave Filter 2.4 MHz 50 Ω BalunmFmF	Xtal

