

FEATURES

Latch-up proof

8 kV human body model (HBM) ESD rating

Low on resistance (<10 Ω)

± 9 V to ± 22 V dual-supply operation

9 V to 40 V single-supply operation

48 V supply maximum ratings

Fully specified at ± 15 V, ± 20 V, +12 V, and +36 V

V_{SS} to V_{DD} analog signal range

APPLICATIONS

Relay replacement

Automatic test equipment

Data acquisition

Instrumentation

Avionics

Audio and video switching

Communication systems

GENERAL DESCRIPTION

The ADG5412/ADG5413 contain four independent single-pole/single-throw (SPST) switches. The ADG5412 switches turn on with Logic 1. The ADG5413 has two switches with digital control logic similar to that of the ADG5412; however, the logic is inverted on the other two switches. Each switch conducts equally well in both directions when on, and each switch has an input signal range that extends to the supplies. In the off condition, signal levels up to the supplies are blocked.

The ADG5412 and ADG5413 do not have a V_L pin. The digital inputs are compatible with 3 V logic inputs over the full operating supply range.

The on-resistance profile is very flat over the full analog input range, which ensures good linearity and low distortion when switching audio signals. High switching speed also makes the devices suitable for video signal switching. The ADG5413

FUNCTIONAL BLOCK DIAGRAMS

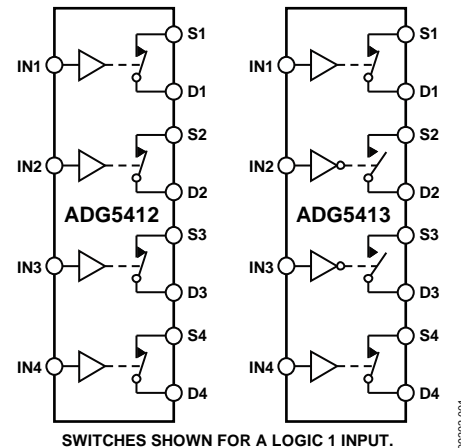

Figure 1.

exhibits break-before-make switching action for use in multiplexer applications.

PRODUCT HIGHLIGHTS

1. Trench isolation guards against latch-up. A dielectric trench separates the P and N channel transistors thereby preventing latch-up even under severe overvoltage conditions.
2. Low R_{ON} .
3. Dual-supply operation. For applications where the analog signal is bipolar, the ADG5412/ADG5413 can be operated from dual supplies up to ± 22 V.
4. Single-supply operation. For applications where the analog signal is unipolar, the ADG5412/ADG5413 can be operated from a single rail power supply up to 40 V.
5. 3 V logic compatible digital inputs: $V_{INH} = 2.0$ V, $V_{INL} = 0.8$ V.
6. No V_L logic power supply required.

Rev. 0

Information furnished by Analog Devices is believed to be accurate and reliable. However, no responsibility is assumed by Analog Devices for its use, nor for any infringements of patents or other rights of third parties that may result from its use. Specifications subject to change without notice. No license is granted by implication or otherwise under any patent or patent rights of Analog Devices. Trademarks and registered trademarks are the property of their respective owners.

TABLE OF CONTENTS

Features	1	Continuous Current per Channel, Sx or Dx.....	7
Applications.....	1	Absolute Maximum Ratings	8
Functional Block Diagrams.....	1	ESD Caution.....	8
General Description	1	Pin Configurations and Function Descriptions	9
Product Highlights	1	Typical Performance Characteristics	10
Revision History	2	Test Circuits.....	14
Specifications.....	3	Terminology	16
±15 V Dual Supply	3	Trench Isolation	17
±20 V Dual Supply	4	Applications Information	18
12 V Single Supply.....	5	Outline Dimensions	19
36 V Single Supply.....	6	Ordering Guide	19

REVISION HISTORY

7/10—Revision 0: Initial Version

SPECIFICATIONS

±15 V DUAL SUPPLY

$V_{DD} = +15\text{ V} \pm 10\%$, $V_{SS} = -15\text{ V} \pm 10\%$, $GND = 0\text{ V}$, unless otherwise noted.

Table 1.

Parameter	25°C	-40°C to +85°C	-40°C to +125°C	Unit	Test Conditions/Comments
ANALOG SWITCH					
Analog Signal Range			V_{DD} to V_{SS}	V	
On Resistance, R_{ON}	9.8			Ω typ	$V_S = \pm 10\text{ V}$, $I_S = -10\text{ mA}$; see Figure 24
On-Resistance Match Between Channels, ΔR_{ON}	11	14	16	Ω max	$V_{DD} = +13.5\text{ V}$, $V_{SS} = -13.5\text{ V}$
	0.35			Ω typ	$V_S = \pm 10\text{ V}$, $I_S = -10\text{ mA}$
On-Resistance Flatness, $R_{FLAT(ON)}$	0.7	0.9	1.1	Ω max	
	1.2			Ω typ	$V_S = \pm 10\text{ V}$, $I_S = -10\text{ mA}$
	1.6	2	2.2	Ω max	
LEAKAGE CURRENTS					
Source Off Leakage, I_S (Off)	± 0.05			nA typ	$V_{DD} = +16.5\text{ V}$, $V_{SS} = -16.5\text{ V}$ $V_S = \pm 10\text{ V}$, $V_D = \mp 10\text{ V}$; see Figure 27
Drain Off Leakage, I_D (Off)	± 0.25	± 0.75	± 3.5	nA max	
	± 0.05			nA typ	$V_S = \pm 10\text{ V}$, $V_D = \mp 10\text{ V}$; see Figure 27
Channel On Leakage, I_D (On), I_S (On)	± 0.25	± 0.75	± 3.5	nA max	
	± 0.1			nA typ	$V_S = V_D = \pm 10\text{ V}$; see Figure 23
	± 0.4	± 2	± 12	nA max	
DIGITAL INPUTS					
Input High Voltage, V_{INH}			2.0	V min	
Input Low Voltage, V_{INL}			0.8	V max	
Input Current, I_{INL} or I_{INH}	0.002			μA typ	$V_{IN} = V_{GND}$ or V_{DD}
			± 0.1	μA max	
Digital Input Capacitance, C_{IN}	2.5			pF typ	
DYNAMIC CHARACTERISTICS¹					
t_{ON}	170			ns typ	$R_L = 300\ \Omega$, $C_L = 35\text{ pF}$
	202	236	262	ns max	$V_S = 10\text{ V}$; see Figure 31
t_{OFF}	120			ns typ	$R_L = 300\ \Omega$, $C_L = 35\text{ pF}$
	145	170	182	ns max	$V_S = 10\text{ V}$; see Figure 31
Break-Before-Make Time Delay, t_D (ADG5413 Only)	15			ns typ	$R_L = 300\ \Omega$, $C_L = 35\text{ pF}$
			6	ns min	$V_{S1} = V_{S2} = 10\text{ V}$; see Figure 30
Charge Injection, Q_{INJ}	240			pC typ	$V_S = 0\text{ V}$, $R_S = 0\ \Omega$, $C_L = 1\text{ nF}$; see Figure 32
Off Isolation	-78			dB typ	$R_L = 50\ \Omega$, $C_L = 5\text{ pF}$, $f = 1\text{ MHz}$; see Figure 26
Channel-to-Channel Crosstalk	-70			dB typ	$R_L = 50\ \Omega$, $C_L = 5\text{ pF}$, $f = 1\text{ MHz}$; see Figure 25
Total Harmonic Distortion + Noise	0.009			% typ	$R_L = 1\text{ k}\Omega$, 15 V p-p , $f = 20\text{ Hz}$ to 20 kHz ; see Figure 28
-3 dB Bandwidth	167			MHz typ	$R_L = 50\ \Omega$, $C_L = 5\text{ pF}$; see Figure 29
Insertion Loss	-0.7			dB typ	$R_L = 50\ \Omega$, $C_L = 5\text{ pF}$, $f = 1\text{ MHz}$; see Figure 29
C_S (Off)	18			pF typ	$V_S = 0\text{ V}$, $f = 1\text{ MHz}$
C_D (Off)	18			pF typ	$V_S = 0\text{ V}$, $f = 1\text{ MHz}$
C_D (On), C_S (On)	60			pF typ	$V_S = 0\text{ V}$, $f = 1\text{ MHz}$

ADG5412/ADG5413

Parameter	25°C	-40°C to +85°C	-40°C to +125°C	Unit	Test Conditions/Comments
POWER REQUIREMENTS					
I_{DD}	45			$\mu\text{A typ}$	$V_{DD} = +16.5\text{ V}$, $V_{SS} = -16.5\text{ V}$ Digital inputs = 0 V or V_{DD}
I_{SS}	55		70	$\mu\text{A max}$	
	0.001			$\mu\text{A typ}$	Digital inputs = 0 V or V_{DD}
			1	$\mu\text{A max}$	
V_{DD}/V_{SS}			$\pm 9/\pm 22$	V min/V max	GND = 0 V

¹ Guaranteed by design; not subject to production test.

$\pm 20\text{ V DUAL SUPPLY}$

$V_{DD} = +20\text{ V} \pm 10\%$, $V_{SS} = -20\text{ V} \pm 10\%$, GND = 0 V, unless otherwise noted.

Table 2.

Parameter	25°C	-40°C to +85°C	-40°C to +125°C	Unit	Test Conditions/Comments
ANALOG SWITCH					
Analog Signal Range			V_{DD} to V_{SS}	V	
On Resistance, R_{ON}	9			Ω typ	$V_S = \pm 15\text{ V}$, $I_S = -10\text{ mA}$; see Figure 24
	10	13	15	Ω max	$V_{DD} = +18\text{ V}$, $V_{SS} = -18\text{ V}$
On-Resistance Match Between Channels, ΔR_{ON}	0.35			Ω typ	$V_S = \pm 15\text{ V}$, $I_S = -10\text{ mA}$
	0.7	0.9	1.1	Ω max	
On-Resistance Flatness, $R_{FLAT(ON)}$	1.5			Ω typ	$V_S = \pm 15\text{ V}$, $I_S = -10\text{ mA}$
	1.8	2.2	2.5	Ω max	
LEAKAGE CURRENTS					
Source Off Leakage, I_S (Off)	± 0.05			nA typ	$V_{DD} = +22\text{ V}$, $V_{SS} = -22\text{ V}$ $V_S = \pm 15\text{ V}$, $V_D = \mp 15\text{ V}$; see Figure 27
	± 0.25	± 0.75	± 3.5	nA max	
Drain Off Leakage, I_D (Off)	± 0.05			nA typ	$V_S = \pm 15\text{ V}$, $V_D = \mp 15\text{ V}$; see Figure 27
	± 0.25	± 0.75	± 3.5	nA max	
Channel On Leakage, I_D (On), I_S (On)	± 0.1			nA typ	$V_S = V_D = \pm 15\text{ V}$; see Figure 23
	± 0.4	± 2	± 12	nA max	
DIGITAL INPUTS					
Input High Voltage, V_{INH}			2.0	V min	
Input Low Voltage, V_{INL}			0.8	V max	
Input Current, I_{INL} or I_{INH}	0.002			$\mu\text{A typ}$	$V_{IN} = V_{GND}$ or V_{DD}
			± 0.1	$\mu\text{A max}$	
Digital Input Capacitance, C_{IN}	2.5			pF typ	
DYNAMIC CHARACTERISTICS¹					
t_{ON}	158			ns typ	$R_L = 300\ \Omega$, $C_L = 35\text{ pF}$
	187	217	240	ns max	$V_S = 10\text{ V}$; see Figure 31
t_{OFF}	110			ns typ	$R_L = 300\ \Omega$, $C_L = 35\text{ pF}$
	138	154	170	ns max	$V_S = 10\text{ V}$; see Figure 31
Break-Before-Make Time Delay, t_D (ADG5413 Only)	12			ns typ	$R_L = 300\ \Omega$, $C_L = 35\text{ pF}$
			5	ns min	$V_{S1} = V_{S2} = 10\text{ V}$; see Figure 30
Charge Injection, Q_{INJ}	310			pC typ	$V_S = 0\text{ V}$, $R_S = 0\ \Omega$, $C_L = 1\text{ nF}$; see Figure 32
Off Isolation	-78			dB typ	$R_L = 50\ \Omega$, $C_L = 5\text{ pF}$, $f = 1\text{ MHz}$; see Figure 26
Channel-to-Channel Crosstalk	-70			dB typ	$R_L = 50\ \Omega$, $C_L = 5\text{ pF}$, $f = 1\text{ MHz}$; see Figure 25

Parameter	25°C	-40°C to +85°C	-40°C to +125°C	Unit	Test Conditions/Comments
Total Harmonic Distortion + Noise	0.007			% typ	$R_L = 1\text{ k}\Omega$, 20 V p-p, $f = 20\text{ Hz}$ to 20 kHz; see Figure 28
-3 dB Bandwidth	160			MHz typ	$R_L = 50\ \Omega$, $C_L = 5\text{ pF}$; see Figure 29
Insertion Loss	-0.6			dB typ	$R_L = 50\ \Omega$, $C_L = 5\text{ pF}$, $f = 1\text{ MHz}$; see Figure 29
C_S (Off)	17			pF typ	$V_S = 0\text{ V}$, $f = 1\text{ MHz}$
C_D (Off)	17			pF typ	$V_S = 0\text{ V}$, $f = 1\text{ MHz}$
C_D (On), C_S (On)	60			pF typ	$V_S = 0\text{ V}$, $f = 1\text{ MHz}$
POWER REQUIREMENTS					
I_{DD}	50			μA typ	$V_{DD} = +22\text{ V}$, $V_{SS} = -22\text{ V}$
	70		110	μA max	Digital inputs = 0 V or V_{DD}
I_{SS}	0.001			μA typ	Digital inputs = 0 V or V_{DD}
V_{DD}/V_{SS}			$\pm 9/\pm 22$	V min/V max	GND = 0 V

¹ Guaranteed by design; not subject to production test.

12 V SINGLE SUPPLY

$V_{DD} = 12\text{ V} \pm 10\%$, $V_{SS} = 0\text{ V}$, GND = 0 V, unless otherwise noted.

Table 3.

Parameter	25°C	-40°C to +85°C	-40°C to +125°C	Unit	Test Conditions/Comments
ANALOG SWITCH					
Analog Signal Range			0 V to V_{DD}	V	
On Resistance, R_{ON}	19			Ω typ	$V_S = 0\text{ V}$ to 10 V, $I_S = -10\text{ mA}$; see Figure 24
	22	27	31	Ω max	$V_{DD} = 10.8\text{ V}$, $V_{SS} = 0\text{ V}$
On-Resistance Match Between Channels, ΔR_{ON}	0.4			Ω typ	$V_S = 0\text{ V}$ to 10 V, $I_S = -10\text{ mA}$
	0.8	1	1.2	Ω max	
On-Resistance Flatness, $R_{FLAT(ON)}$	4.4			Ω typ	$V_S = 0\text{ V}$ to 10 V, $I_S = -10\text{ mA}$
	5.5	6.5	7.5	Ω max	
LEAKAGE CURRENTS					
Source Off Leakage, I_S (Off)	± 0.05			nA typ	$V_{DD} = 13.2\text{ V}$, $V_{SS} = 0\text{ V}$ $V_S = 1\text{ V}/10\text{ V}$, $V_D = 10\text{ V}/1\text{ V}$; see Figure 27
	± 0.25	± 0.75	± 3.5	nA max	
Drain Off Leakage, I_D (Off)	± 0.05			nA typ	$V_S = 1\text{ V}/10\text{ V}$, $V_D = 10\text{ V}/1\text{ V}$; see Figure 27
	± 0.25	± 0.75	± 3.5	nA max	
Channel On Leakage, I_D (On), I_S (On)	± 0.1			nA typ	$V_S = V_D = 1\text{ V}/10\text{ V}$; see Figure 23
	± 0.4	± 2	± 12	nA max	
DIGITAL INPUTS					
Input High Voltage, V_{INH}			2.0	V min	
Input Low Voltage, V_{INL}			0.8	V max	
Input Current, I_{INL} or I_{INH}	0.002			μA typ	$V_{IN} = V_{GND}$ or V_{DD}
			± 0.1	μA max	
Digital Input Capacitance, C_{IN}	2.5			pF typ	
DYNAMIC CHARACTERISTICS¹					
t_{ON}	225			ns typ	$R_L = 300\ \Omega$, $C_L = 35\text{ pF}$
	296	358	403	ns max	$V_S = 8\text{ V}$; see Figure 31
t_{OFF}	150			ns typ	$R_L = 300\ \Omega$, $C_L = 35\text{ pF}$
	187	222	247	ns max	$V_S = 8\text{ V}$; see Figure 31

ADG5412/ADG5413

Parameter	25°C	-40°C to +85°C	-40°C to +125°C	Unit	Test Conditions/Comments
Break-Before-Make Time Delay, t_D (ADG5413 Only)	70			ns typ	$R_L = 300 \Omega$, $C_L = 35 \text{ pF}$
Charge Injection, Q_{INJ}	95		38	ns min pC typ	$V_{S1} = V_{S2} = 8 \text{ V}$; see Figure 30 $V_S = 6 \text{ V}$, $R_S = 0 \Omega$, $C_L = 1 \text{ nF}$; see Figure 32
Off Isolation	-78			dB typ	$R_L = 50 \Omega$, $C_L = 5 \text{ pF}$, $f = 1 \text{ MHz}$; see Figure 26
Channel-to-Channel Crosstalk	-70			dB typ	$R_L = 50 \Omega$, $C_L = 5 \text{ pF}$, $f = 1 \text{ MHz}$; see Figure 25
Total Harmonic Distortion + Noise	0.07			% typ	$R_L = 1 \text{ k}\Omega$, 6 V p-p , $f = 20 \text{ Hz}$ to 20 kHz ; see Figure 28
-3 dB Bandwidth	180			MHz typ	$R_L = 50 \Omega$, $C_L = 5 \text{ pF}$; see Figure 29
Insertion Loss	-1.3			dB typ	$R_L = 50 \Omega$, $C_L = 5 \text{ pF}$, $f = 1 \text{ MHz}$; see Figure 29
C_S (Off)	22			pF typ	$V_S = 6 \text{ V}$, $f = 1 \text{ MHz}$
C_D (Off)	22			pF typ	$V_S = 6 \text{ V}$, $f = 1 \text{ MHz}$
C_D (On), C_S (On)	58			pF typ	$V_S = 6 \text{ V}$, $f = 1 \text{ MHz}$
POWER REQUIREMENTS					
I_{DD}	40		65	$\mu\text{A typ}$ $\mu\text{A max}$	$V_{DD} = 13.2 \text{ V}$ Digital inputs = 0 V or V_{DD}
V_{DD}			9/40	V min/V max	$\text{GND} = 0 \text{ V}$, $V_{SS} = 0 \text{ V}$

¹ Guaranteed by design; not subject to production test.

36 V SINGLE SUPPLY

$V_{DD} = 36 \text{ V} \pm 10\%$, $V_{SS} = 0 \text{ V}$, $\text{GND} = 0 \text{ V}$, unless otherwise noted.

Table 4.

Parameter	25°C	-40°C to +85°C	-40°C to +125°C	Unit	Test Conditions/Comments
ANALOG SWITCH					
Analog Signal Range			$0 \text{ V to } V_{DD}$	V	
On Resistance, R_{ON}	10.6			$\Omega \text{ typ}$	$V_S = 0 \text{ V to } 30 \text{ V}$, $I_S = -10 \text{ mA}$; see Figure 24
On-Resistance Match Between Channels, ΔR_{ON}	0.35	15	17	$\Omega \text{ max}$ $\Omega \text{ typ}$	$V_{DD} = 32.4 \text{ V}$, $V_{SS} = 0 \text{ V}$ $V_S = 0 \text{ V to } 30 \text{ V}$, $I_S = -10 \text{ mA}$
On-Resistance Flatness, $R_{FLAT(ON)}$	0.7	0.9	1.1	$\Omega \text{ max}$ $\Omega \text{ typ}$ $\Omega \text{ max}$	$V_S = 0 \text{ V to } 30 \text{ V}$, $I_S = -10 \text{ mA}$
	3.2	3.8	4.5		
LEAKAGE CURRENTS					
Source Off Leakage, I_S (Off)	± 0.05			nA typ	$V_{DD} = 39.6 \text{ V}$, $V_{SS} = 0 \text{ V}$ $V_S = 1 \text{ V}/30 \text{ V}$, $V_D = 30 \text{ V}/1 \text{ V}$; see Figure 27
Drain Off Leakage, I_D (Off)	± 0.25 ± 0.05	± 0.75	± 3.5	nA max nA typ	$V_S = 1 \text{ V}/30 \text{ V}$, $V_D = 30 \text{ V}/1 \text{ V}$; see Figure 27
Channel On Leakage, I_D (On), I_S (On)	± 0.25 ± 0.1	± 0.75	± 3.5	nA max nA typ	$V_S = V_D = 1 \text{ V}/30 \text{ V}$; see Figure 23
	± 0.4	± 2	± 12	nA max	

Parameter	25°C	-40°C to +85°C	-40°C to +125°C	Unit	Test Conditions/Comments
DIGITAL INPUTS					
Input High Voltage, V_{INH}			2.0	V min	$V_{IN} = V_{GND}$ or V_{DD}
Input Low Voltage, V_{INL}			0.8	V max	
Input Current, I_{INL} or I_{INH}	0.002		±0.1	μA typ μA max	
Digital Input Capacitance, C_{IN}	2.5			pF typ	
DYNAMIC CHARACTERISTICS¹					
t_{ON}	180			ns typ	$R_L = 300 \Omega$, $C_L = 35$ pF
	220	230	248	ns max	$V_S = 18$ V; see Figure 31
t_{OFF}	130			ns typ	$R_L = 300 \Omega$, $C_L = 35$ pF
	169	167	174	ns max	$V_S = 18$ V; see Figure 31
Break-Before-Make Time Delay, t_D (ADG5413 Only)	25			ns typ	$R_L = 300 \Omega$, $C_L = 35$ pF
Charge Injection, Q_{INJ}			8	ns min	$V_{S1} = V_{S2} = 18$ V; see Figure 30
	280			pC typ	$V_S = 18$ V, $R_S = 0 \Omega$, $C_L = 1$ nF; see Figure 32
Off Isolation	-78			dB typ	$R_L = 50 \Omega$, $C_L = 5$ pF, $f = 1$ MHz; see Figure 26
Channel-to-Channel Crosstalk	-70			dB typ	$R_L = 50 \Omega$, $C_L = 5$ pF, $f = 1$ MHz; Figure 25
Total Harmonic Distortion + Noise	0.03			% typ	$R_L = 1$ kΩ, 18 V p-p, $f = 20$ Hz to 20 kHz; see Figure 28
-3 dB Bandwidth	174			MHz typ	$R_L = 50 \Omega$, $C_L = 5$ pF; see Figure 29
Insertion Loss	-0.8			dB typ	$R_L = 50 \Omega$, $C_L = 5$ pF, $f = 1$ MHz; see Figure 29
C_S (Off)	18			pF typ	$V_S = 18$ V, $f = 1$ MHz
C_D (Off)	18			pF typ	$V_S = 18$ V, $f = 1$ MHz
C_D (On), C_S (On)	58			pF typ	$V_S = 18$ V, $f = 1$ MHz
POWER REQUIREMENTS					
I_{DD}	80			μA typ	$V_{DD} = 39.6$ V
	100		130	μA max	Digital inputs = 0 V or V_{DD}
V_{DD}			9/40	V min/V max	$GND = 0$ V, $V_{SS} = 0$ V

¹ Guaranteed by design; not subject to production test.

CONTINUOUS CURRENT PER CHANNEL, S_x OR D_x

Table 5.

Parameter	25°C	85°C	125°C	Unit
CONTINUOUS CURRENT, S_x OR D_x				
$V_{DD} = +15$ V, $V_{SS} = -15$ V				
TSSOP ($\theta_{JA} = 112.6^\circ\text{C/W}$)	89	59	37	mA maximum
LFCSP ($\theta_{JA} = 30.4^\circ\text{C/W}$)	160	94	49	mA maximum
$V_{DD} = +20$ V, $V_{SS} = -20$ V				
TSSOP ($\theta_{JA} = 112.6^\circ\text{C/W}$)	95	63	39	mA maximum
LFCSP ($\theta_{JA} = 30.4^\circ\text{C/W}$)	170	98	50	mA maximum
$V_{DD} = 12$ V, $V_{SS} = 0$ V				
TSSOP ($\theta_{JA} = 112.6^\circ\text{C/W}$)	61	43	29	mA maximum
LFCSP ($\theta_{JA} = 30.4^\circ\text{C/W}$)	110	70	42	mA maximum
$V_{DD} = 36$ V, $V_{SS} = 0$ V				
TSSOP ($\theta_{JA} = 112.6^\circ\text{C/W}$)	80	54	35	mA maximum
LFCSP ($\theta_{JA} = 30.4^\circ\text{C/W}$)	144	87	47	mA maximum

ABSOLUTE MAXIMUM RATINGS

T_A = 25°C, unless otherwise noted.

Table 6.

Parameter	Rating
V _{DD} to V _{SS}	48 V
V _{DD} to GND	−0.3 V to +48 V
V _{SS} to GND	+0.3 V to −48 V
Analog Inputs ¹	V _{SS} − 0.3 V to V _{DD} + 0.3 V or 30 mA, whichever occurs first
Digital Inputs ¹	V _{SS} − 0.3 V to V _{DD} + 0.3 V or 30 mA, whichever occurs first
Peak Current, Sx or Dx Pins	278 mA (pulsed at 1 ms, 10% duty cycle maximum)
Continuous Current, Sx or Dx ²	Data + 15%
Temperature Range	
Operating	−40°C to +125°C
Storage	−65°C to +150°C
Junction Temperature	150°C
Thermal Impedance, θ _{JA}	
16-Lead TSSOP (4-Layer Board)	112.6°C/W
16-Lead LFCSP (4-Layer Board)	30.4°C/W
Reflow Soldering Peak Temperature, Pb Free	260(+0/−5)°C

¹ Overvoltages at the INx, Sx, and Dx pins are clamped by internal diodes. Limit current to the maximum ratings given.

² See Table 5.

Stresses above those listed under Absolute Maximum Ratings may cause permanent damage to the device. This is a stress rating only; functional operation of the device at these or any other conditions above those indicated in the operational section of this specification is not implied. Exposure to absolute maximum rating conditions for extended periods may affect device reliability.

Only one absolute maximum rating can be applied at any one time.

ESD CAUTION



ESD (electrostatic discharge) sensitive device. Charged devices and circuit boards can discharge without detection. Although this product features patented or proprietary protection circuitry, damage may occur on devices subjected to high energy ESD. Therefore, proper ESD precautions should be taken to avoid performance degradation or loss of functionality.

PIN CONFIGURATIONS AND FUNCTION DESCRIPTIONS

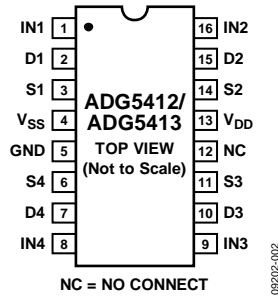
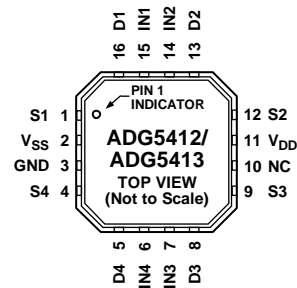

Figure 2. TSSOP Pin Configuration



NOTES
 1. EXPOSED PAD TIED TO SUBSTRATE, V_{SS} .
 2. NC = NO CONNECT.

Figure 3. LFCSP Pin Configuration

Table 7. Pin Function Descriptions

Pin No.		Mnemonic	Description
TSSOP	LFCSP		
1	15	IN1	Logic Control Input 1.
2	16	D1	Drain Terminal 1. This pin can be an input or output.
3	1	S1	Source Terminal 1. This pin can be an input or output.
4	2	V_{SS}	Most Negative Power Supply Potential.
5	3	GND	Ground (0 V) Reference.
6	4	S4	Source Terminal 4. This pin can be an input or output.
7	5	D4	Drain Terminal 4. This pin can be an input or output.
8	6	IN4	Logic Control Input 4.
9	7	IN3	Logic Control Input 3.
10	8	D3	Drain Terminal 3. This pin can be an input or output.
11	9	S3	Source Terminal 3. This pin can be an input or output.
12	10	NC	No Connection.
13	11	V_{DD}	Most Positive Power Supply Potential.
14	12	S2	Source Terminal 2. This pin can be an input or output.
15	13	D2	Drain Terminal 2. This pin can be an input or output.
16	14	IN2	Logic Control Input 2.
	EP	Exposed Pad	The exposed pad is connected internally. For increased reliability of the solder joints and maximum thermal capability, it is recommended that the pad be soldered to the substrate, V_{SS} .

Table 8. ADG5412 Truth Table

INx	Switch Condition
1	On
0	Off

Table 9. ADG5413 Truth Table

INx	S1, S4	S2, S3
0	Off	On
1	On	Off

TYPICAL PERFORMANCE CHARACTERISTICS

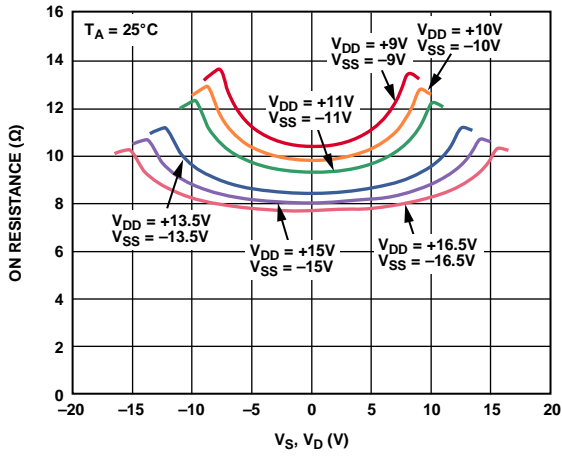

Figure 4. R_{ON} as a Function of V_S , V_D (Dual Supply)

09202-034

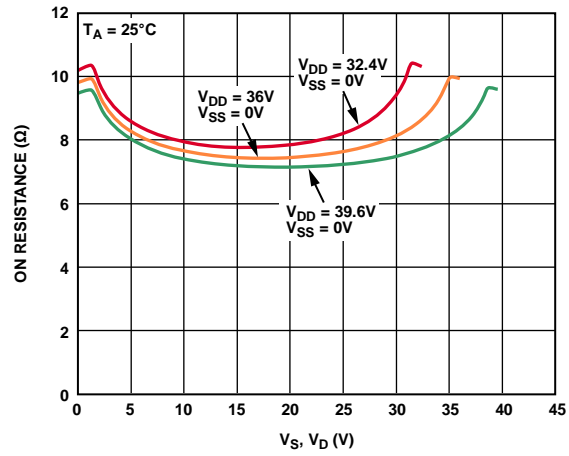

Figure 7. R_{ON} as a Function of V_S , V_D (Single Supply)

09202-033

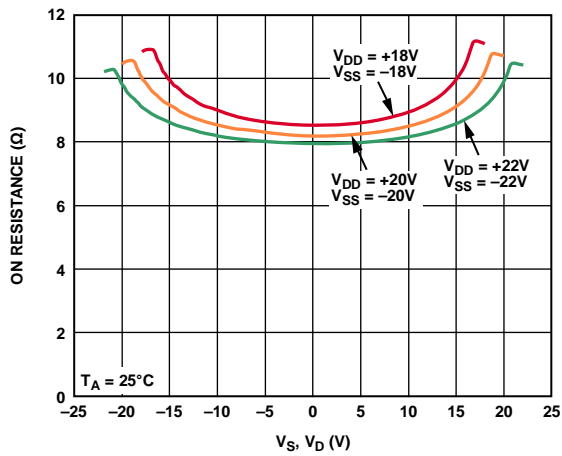

Figure 5. R_{ON} as a Function of V_S , V_D (Dual Supply)

09202-035

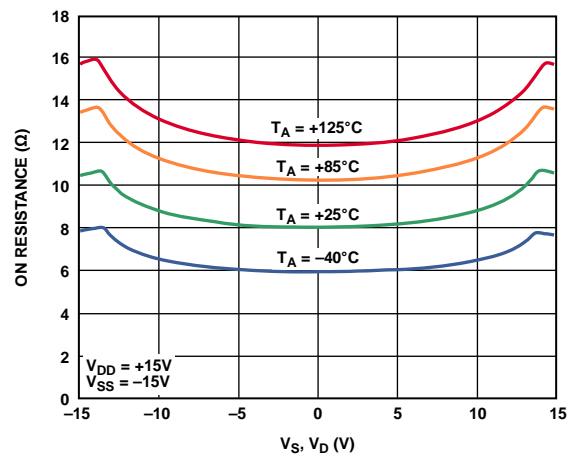

Figure 8. R_{ON} as a Function of V_S (V_D) for Different Temperatures, ± 15 V Dual Supply

09202-040

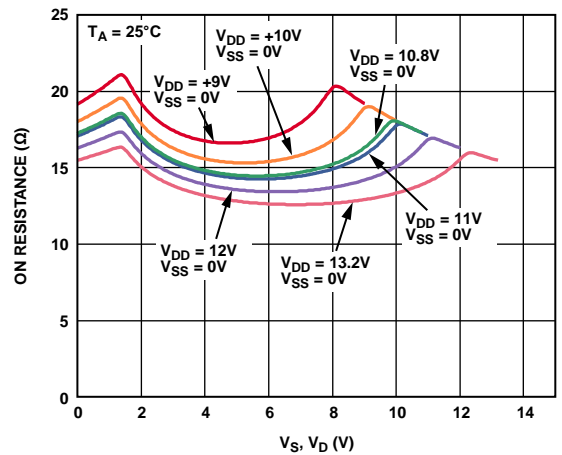

Figure 6. R_{ON} as a Function of V_S , V_D (Single Supply)

09202-032

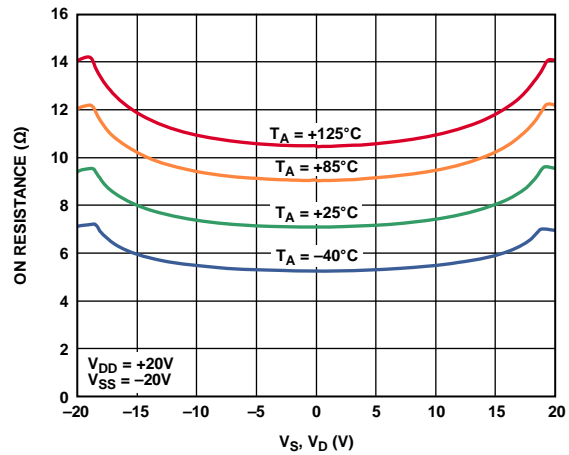

Figure 9. R_{ON} as a Function of V_S (V_D) for Different Temperatures, ± 20 V Dual Supply

09202-041

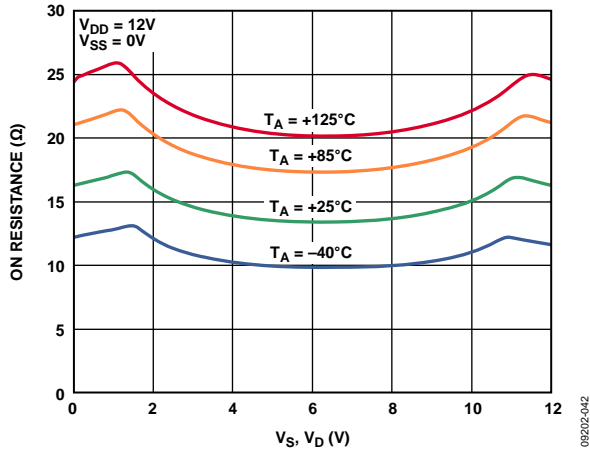

Figure 10. R_{ON} as a Function of V_S (V_D) for Different Temperatures, 12 V Single Supply

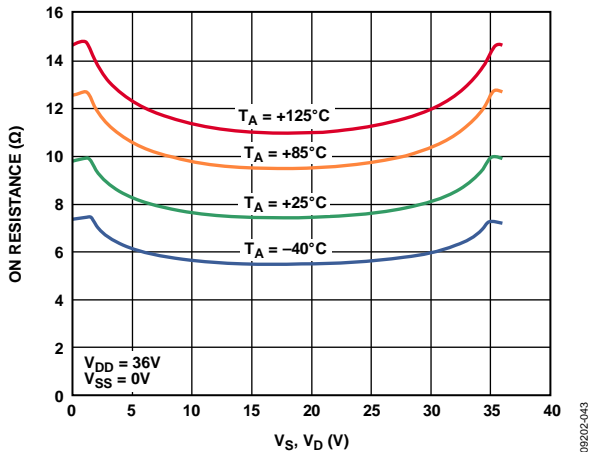

Figure 11. R_{ON} as a Function of V_S (V_D) for Different Temperatures, 36 V Single Supply

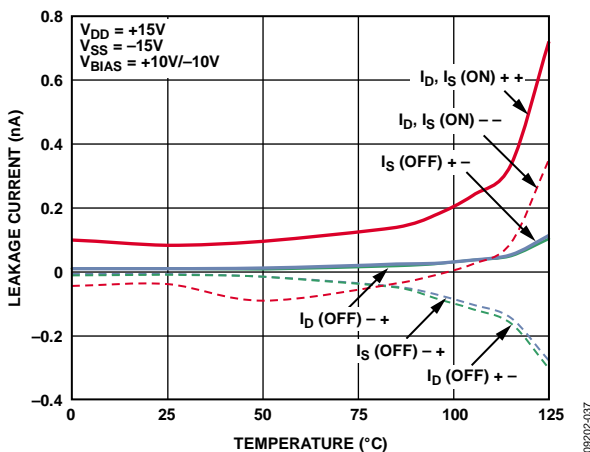

Figure 12. Leakage Currents vs. Temperature, $\pm 15\text{V}$ Dual Supply

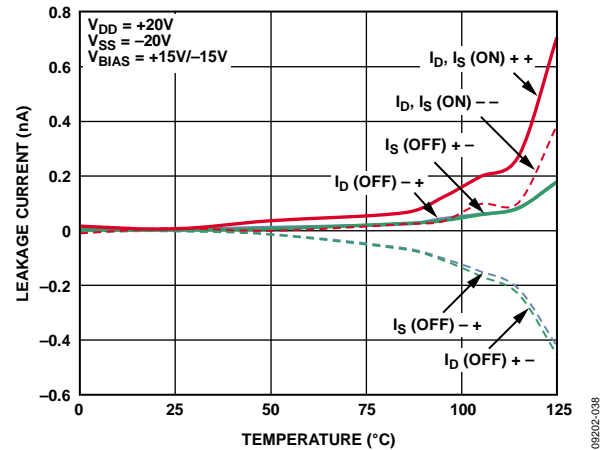

Figure 13. Leakage Currents vs. Temperature, $\pm 20\text{V}$ Dual Supply

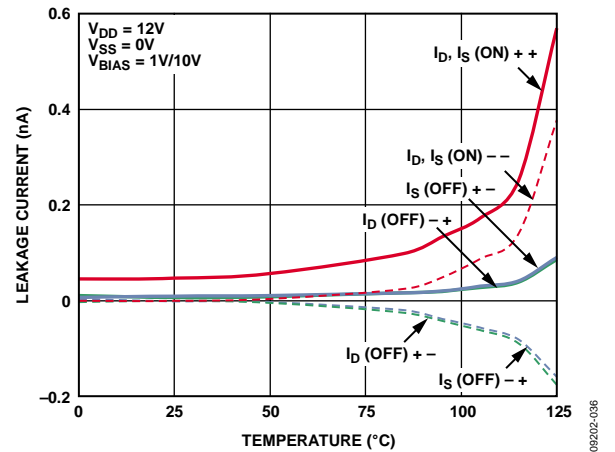

Figure 14. Leakage Currents vs. Temperature, 12 V Single Supply

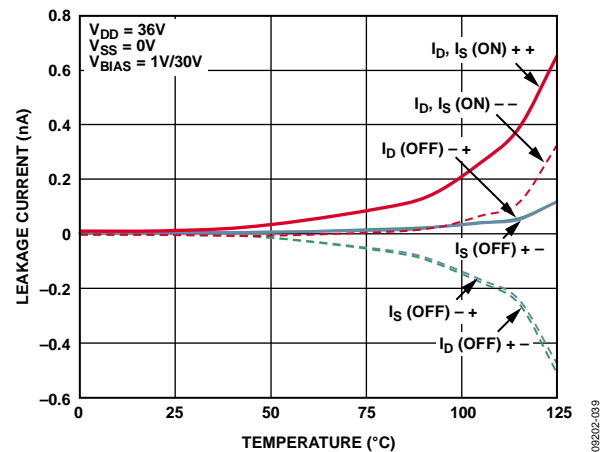

Figure 15. Leakage Currents vs. Temperature, 36 V Single Supply

ADG5412/ADG5413

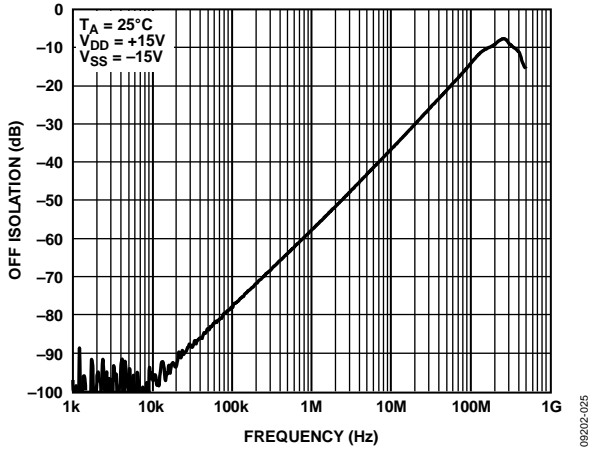

Figure 16. Off Isolation vs. Frequency, ±15 V Dual Supply

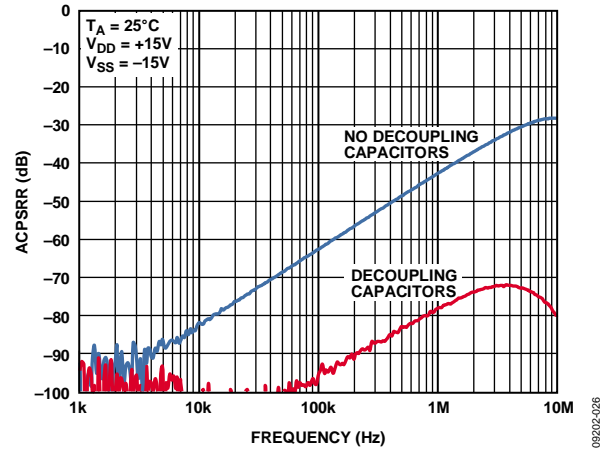

Figure 19. ACPSRR vs. Frequency, ±15 V Dual Supply

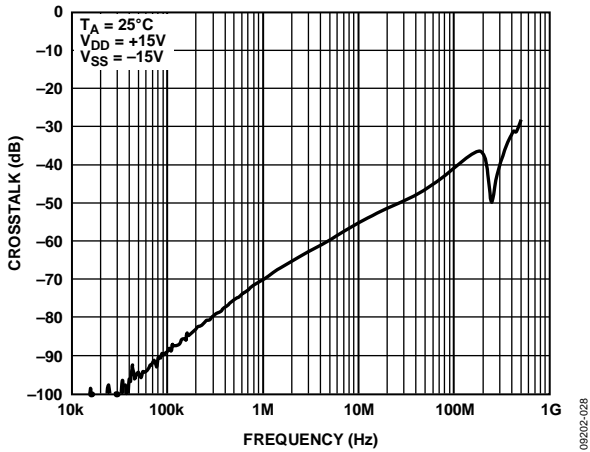

Figure 17. Crosstalk vs. Frequency, ±15 V Dual Supply

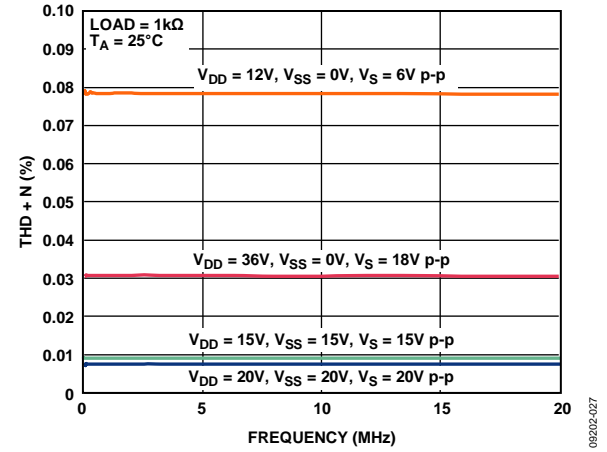

Figure 20. THD + N vs. Frequency, ±15 V Dual Supply

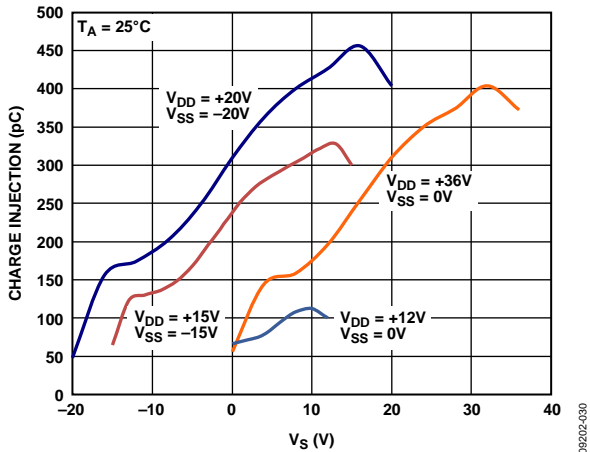

Figure 18. Charge Injection vs. Source Voltage

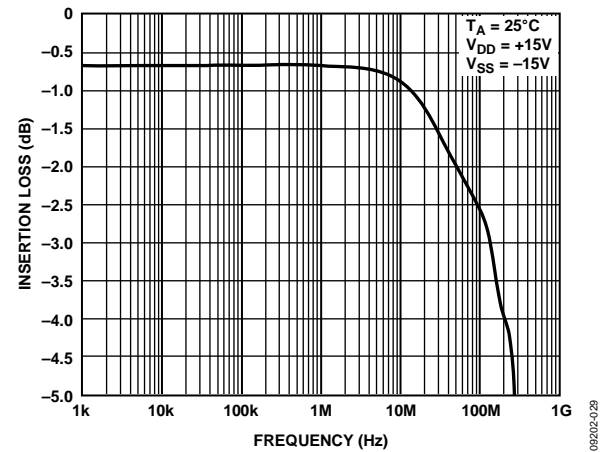

Figure 21. Bandwidth

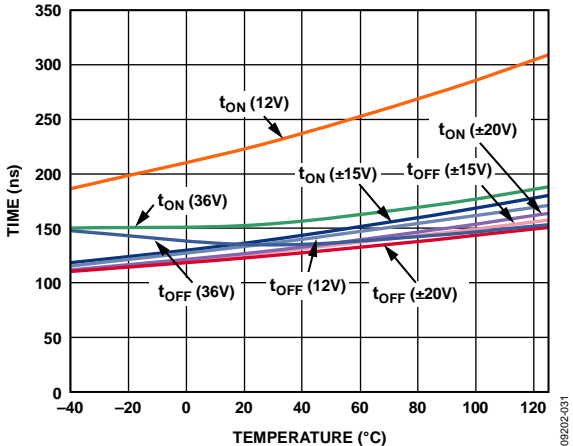

Figure 22. t_{ON}, t_{OFF} Times vs. Temperature

TEST CIRCUITS

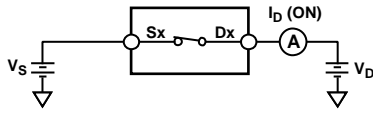

Figure 23. On Leakage

09202-016

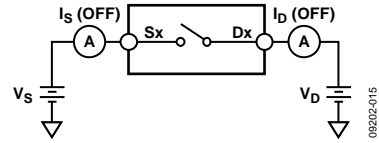

Figure 27. Off Leakage

09202-015

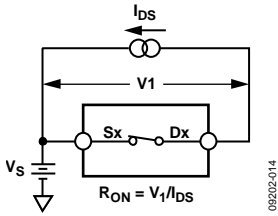

Figure 24. On Resistance

09202-014

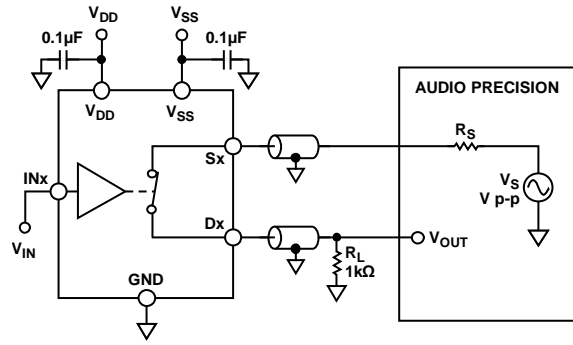
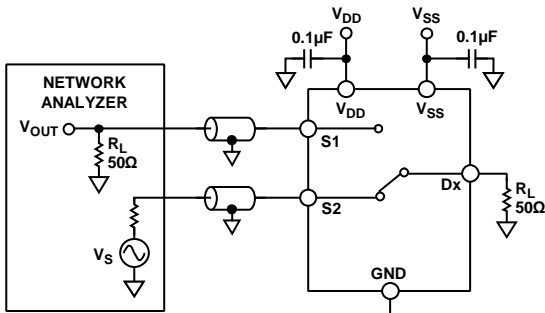

Figure 28. THD + Noise

09202-024



$$\text{CHANNEL-TO-CHANNEL CROSSTALK} = 20 \log \frac{V_{OUT}}{V_s}$$

Figure 25. Channel-to-Channel Crosstalk

09202-021

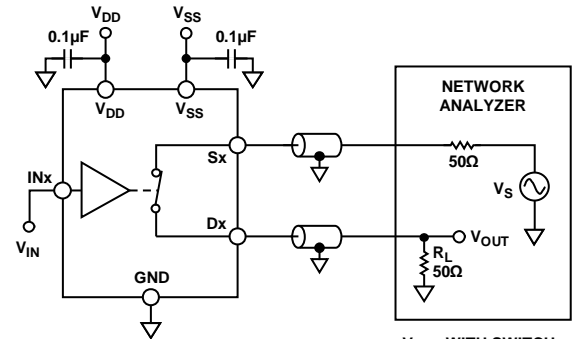

$$\text{INSERTION LOSS} = 20 \log \frac{V_{OUT \text{ WITH SWITCH}}}{V_{OUT \text{ WITHOUT SWITCH}}}$$

Figure 29. Bandwidth

09202-023

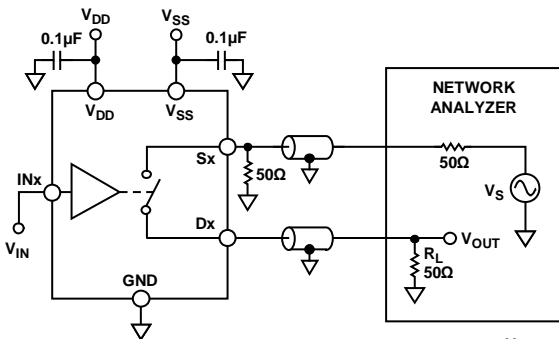

$$\text{OFF ISOLATION} = 20 \log \frac{V_{OUT}}{V_s}$$

Figure 26. Off Isolation

09202-020

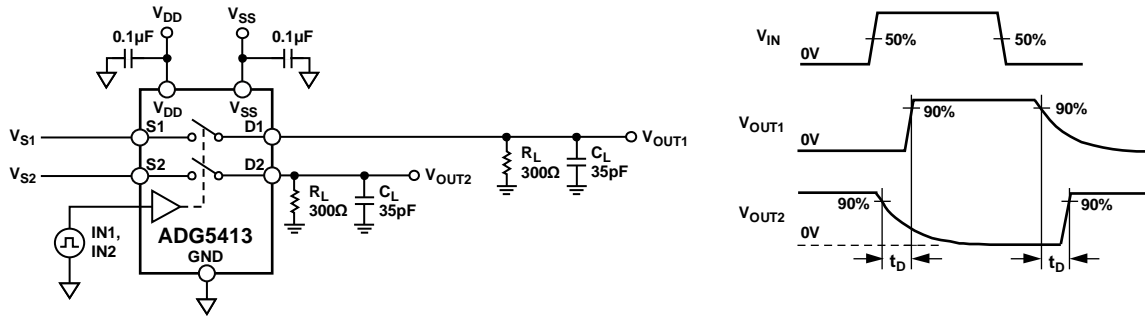

Figure 30. Break-Before-Make Time Delay, t_D

06202-017

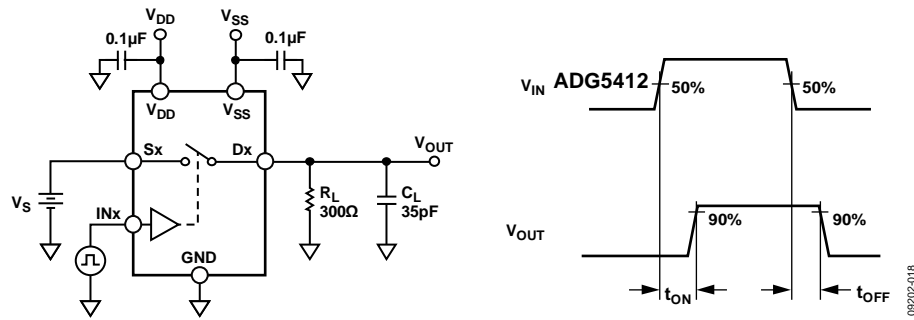

Figure 31. Switching Times

06202-018

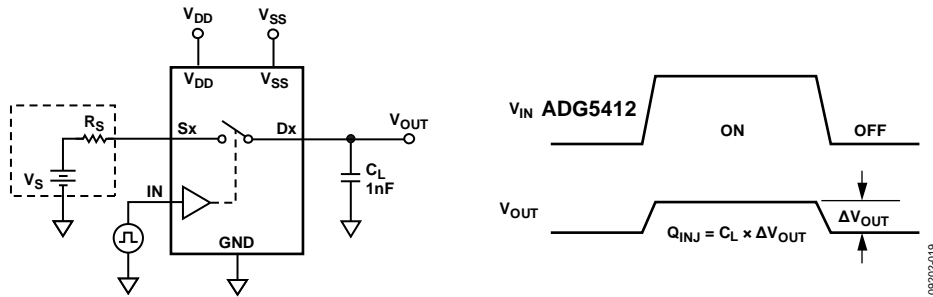

Figure 32. Charge Injection

06202-019

TERMINOLOGY

I_{DD}

I_{DD} represents the positive supply current.

I_{SS}

I_{SS} represents the negative supply current.

V_D, V_S

V_D and V_S represent the analog voltage on Terminal D and Terminal S, respectively.

R_{ON}

R_{ON} represents the ohmic resistance between Terminal D and Terminal S.

ΔR_{ON}

ΔR_{ON} represents the difference between the R_{ON} of any two channels.

$R_{FLAT(ON)}$

Flatness that is defined as the difference between the maximum and minimum value of on resistance measured over the specified analog signal range is represented by $R_{FLAT(ON)}$.

I_S (Off)

I_S (Off) is the source leakage current with the switch off.

I_D (Off)

I_D (Off) is the drain leakage current with the switch off.

I_D (On), I_S (On)

I_D (On) and I_S (On) represent the channel leakage currents with the switch on.

V_{INL}

V_{INL} is the maximum input voltage for Logic 0.

V_{INH}

V_{INH} is the minimum input voltage for Logic 1.

I_{INL}, I_{INH}

I_{INL} and I_{INH} represent the low and high input currents of the digital inputs.

C_D (Off)

C_D (Off) represents the off switch drain capacitance, which is measured with reference to ground.

C_S (Off)

C_S (Off) represents the off switch source capacitance, which is measured with reference to ground.

C_D (On), C_S (On)

C_D (On) and C_S (On) represent on switch capacitances, which are measured with reference to ground.

C_{IN}

C_{IN} is the digital input capacitance.

t_{ON}

t_{ON} represents the delay between applying the digital control input and the output switching on.

t_{OFF}

t_{OFF} represents the delay between applying the digital control input and the output switching off.

t_D

t_D represents the off time measured between the 80% point of both switches when switching from one address state to another.

Off Isolation

Off isolation is a measure of unwanted signal coupling through an off switch.

Charge Injection

Charge injection is a measure of the glitch impulse transferred from the digital input to the analog output during switching.

Crosstalk

Crosstalk is a measure of unwanted signal that is coupled through from one channel to another as a result of parasitic capacitance.

Bandwidth

Bandwidth is the frequency at which the output is attenuated by 3 dB.

On Response

On response is the frequency response of the on switch.

Insertion Loss

Insertion loss is the loss due to the on resistance of the switch.

Total Harmonic Distortion + Noise (THD + N)

The ratio of the harmonic amplitude plus noise of the signal to the fundamental is represented by THD + N.

AC Power Supply Rejection Ratio (ACPSRR)

ACPSRR is the ratio of the amplitude of signal on the output to the amplitude of the modulation. This is a measure of the ability of the part to avoid coupling noise and spurious signals that appear on the supply voltage pin to the output of the switch. The dc voltage on the device is modulated by a sine wave of 0.62 V p-p.

TRENCH ISOLATION

In the ADG5412 and ADG5413, an insulating oxide layer (trench) is placed between the NMOS and the PMOS transistors of each CMOS switch. Parasitic junctions, which occur between the transistors in junction isolated switches, are eliminated, and the result is a completely latch-up proof switch.

In junction isolation, the N and P wells of the PMOS and NMOS transistors form a diode that is reverse-biased under normal operation. However, during overvoltage conditions, this diode can become forward-biased. A silicon controlled rectifier (SCR) type circuit is formed by the two transistors causing a significant amplification of the current that, in turn, leads to latch-up. With trench isolation, this diode is removed, and the result is a latch-up proof switch.

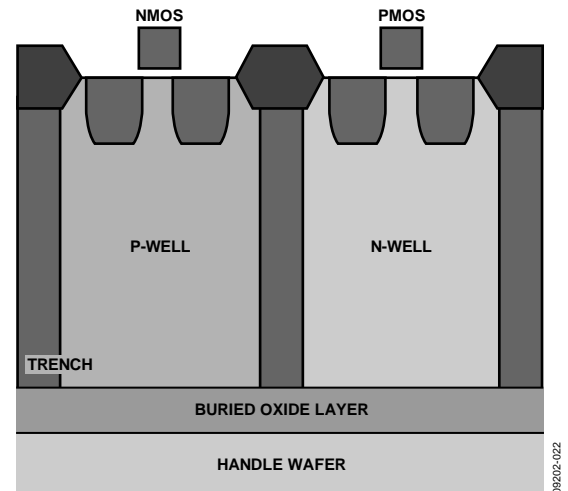

Figure 33. Trench Isolation

APPLICATIONS INFORMATION

The ADG54xx family of switches and multiplexers provide a robust solution for instrumentation, industrial, automotive, aerospace, and other harsh environments that are prone to latch-up, which is an undesirable high current state that can lead to device failure and persists until the power supply is turned off. The ADG5412/ADG5413 high voltage switches

allow single-supply operation from 9 V to 40 V and dual-supply operation from ± 9 V to ± 22 V. The ADG5412/ADG5413 (as well as other select devices within the same family) achieve an 8 kV human body model ESD rating, which provides a robust solution eliminating the need for separate protect circuitry designs in some applications.

OUTLINE DIMENSIONS

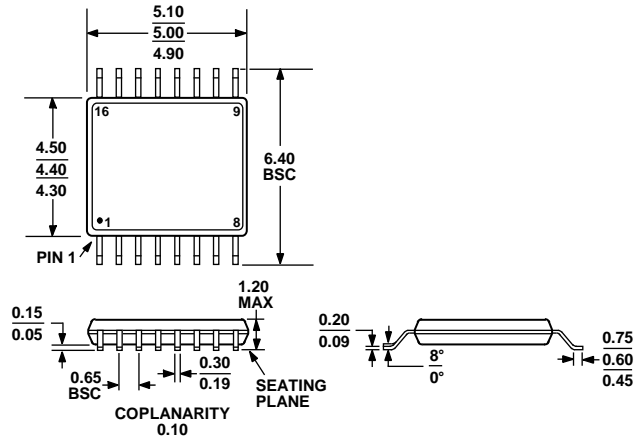

COMPLIANT TO JEDEC STANDARDS MO-153-AB

Figure 34. 16-Lead Thin Shrink Small Outline Package [TSSOP] (RU-16)

Dimensions shown in millimeters

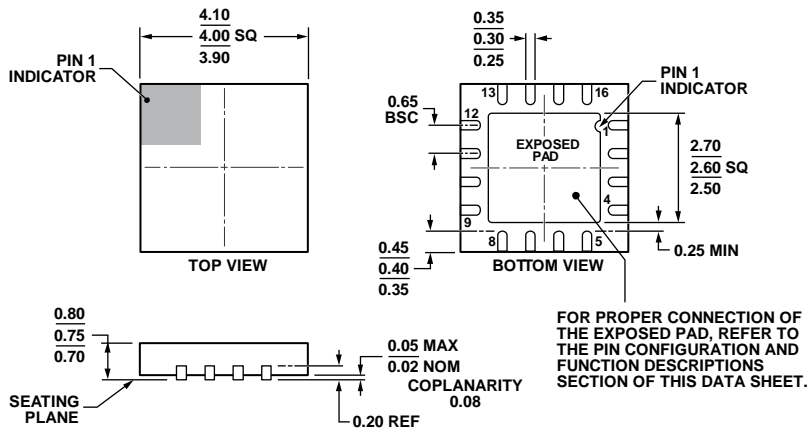

COMPLIANT TO JEDEC STANDARDS MO-220-WGGC.

Figure 35. 16-Lead Lead Frame Chip Scale Package [LFCSP_VQ] 4 mm x 4 mm Body, Very Very Thin Quad (CP-16-17)

Dimensions shown in millimeters

ORDERING GUIDE

Model ¹	Temperature Range	Package Description	Package Option
ADG5412BRUZ	-40°C to +125°C	16-Lead Thin Shrink Small Outline Package [TSSOP]	RU-16
ADG5412BRUZ-REEL7	-40°C to +125°C	16-Lead Thin Shrink Small Outline Package [TSSOP]	RU-16
ADG5412BCPZ-REEL7	-40°C to +125°C	16-Lead Lead Frame Chip Scale Package [LFCSP_VQ]	CP-16-17
ADG5413BRUZ	-40°C to +125°C	16-Lead Thin Shrink Small Outline Package [TSSOP]	RU-16
ADG5413BRUZ-REEL7	-40°C to +125°C	16-Lead Thin Shrink Small Outline Package [TSSOP]	RU-16
ADG5413BCPZ-REEL7	-40°C to +125°C	16-Lead Lead Frame Chip Scale Package [LFCSP_VQ]	CP-16-17

¹ Z = RoHS Compliant Part.

NOTES