



# ATJ 2085

## PRODUCT DATA SHEET

(Version 1.5 08/2004)

# Actions Semiconductor Co., Ltd

## Declaration

All contents of this document are protected by copyright law and reproduction in whole or in part is prohibited without the prior written consent of Actions Semiconductor Co., Ltd. Other product names used in this publication are for identification purposes only and may be trademarks or registered trademarks of their respective companies.

The information presented in this document does not form part of any quotation or contract, is believed to be accurate and reliable. Actions Semiconductor Co., Ltd. reserves the right to make changes to specifications and product descriptions at any time without notice, and to discontinue or make changes to its products at any time without notice. Actions Semiconductor Co., Ltd. specifically disclaims any and all liability for any consequence of the application or use of any product or circuit. Publication thereof does not convey nor imply any license under patent or other industrial or intellectual property rights.

Actions Semiconductor Co., Ltd. is one of Licensee of Thomson Licensing S.A. and is approved to distribute these semiconductor devices using MPEG Layer-3 (“mp3”) coding technology (“mp3 decoder chips”) by Thomson Licensing S.A. Supply of this product does not convey a license nor imply any right to distribute content created with this product in revenue-generating broadcast systems (terrestrial, satellite, cable and/or other distribution channels), streaming applications (via Internet, intranets and/or other networks), other content distribution systems (pay-audio or audio-on-demand applications and the like) or on physical media (compact discs, digital versatile discs, semiconductor chips, hard drives, memory cards and the like). An independent license for such use is required. For details, please visit <http://mp3licensing.com>.

Actions Semiconductor Co., Ltd. is one of Licensee of Microsoft Licensing, GP. Actions Semiconductor Co., Ltd. is approved to distribute these semiconductor devices using Windows Media Audio (“wma”) coding technology (“wma codec chips”) by Microsoft Licensing, GP. This product includes technology owned by Microsoft Corporation and cannot be used or distributed without a license from Microsoft Licensing, GP.

## ADDITIONAL SUPPORT

Additional product and company information can be obtained by going to the Actions website at: [www.actions.com.cn](http://www.actions.com.cn).

## CONTENTS

Declaration .....	1
CONTENTS.....	2
1. Description .....	4
2. Features .....	4
3. Pin Description .....	6
3.1 Pin Sort by Number .....	6
4. Function Description .....	10
4.1 Functional Block Diagram.....	10
4.2 MCU Core .....	11
4.3 DSP Core.....	11
4.4 DMA Controller .....	11
4.5 General Purpose IO Ports .....	11
4.6 RTC/CTC/Watch Dog Timer.....	13
4.7 Oscillator/PLL.....	13
4.8 Power Management Unit (PMU).....	14
4.9 ADC.....	15
4.10 DAC.....	16
4.11 Headphone Driver.....	17
4.13 External Memory Interface .....	17
4.14 I2C Interface .....	18
4.15 USB 2.0(FS) SIE.....	19
4.15.1 Hard Core .....	20
4.15.2 Interrupts.....	20
4.16 FM Interface.....	20
5. Electrical Characteristics.....	20
5.1 Absolute Maximum Ratings .....	20
5.2 Capacitance .....	21
5.3 DC Characteristics.....	21
5.4 AC Characteristics .....	22
5.4.1 AC test input waveform .....	22

5.4.2 AC test output measuring points .....	22
5.4.3 Reset Parameter .....	22
5.4.4 Initialization Parameter .....	22
5.4.5 GPIO Interface Parameter .....	23
5.4.6 Ordinary ROM Parameter .....	23
5.4.7 External System Bus Parameter .....	24
5.4.8 Bus Operation .....	25
5.4.9 A/D Converter Characteristics .....	27
5.4.10 Headphone Driver Characteristics Table .....	27
5.4.11 LCM Driver Parameter .....	29
6. MCU/DSP Dissipation (IVDD VS. Frequency) .....	30
6.1 MCU Dissipation .....	30
6.2 DSP Dissipation .....	30
7. Recommended Soldering Conditions .....	31
7.1 Soldering Conditions .....	31
7.2 Precaution against ESD for Semiconductors .....	31
7.3 Handling of Unused Input Pins for CMOS .....	31
7.4 Status before Initialization of MOS Devices .....	32
8. Package Drawings .....	33

## 1. Description

ATJ2085 is a single-chip for flash-based digital music player. It includes an audio decoder with a high performance DSP, ADPCM record capabilities and USB interface for downloading music and uploading voice recordings. ATJ2085 also provides an interface to flash memory, LED, button and switch inputs, headphone, and microphone, and FM radio input and control. ATJ2085's programmable architecture supports the MP3, WMA and other digital audio standards. For devices like USB-Disk, ATJ2085 can act as a USB mass storage slave device to personal computer system. Its low power consumption allows a long battery life, and an efficient flexible on-chip DC-DC converter allows many different battery configurations, including 1xAA, 1xAAA, 2xAA, 2xAAA and Li-Ion. Built-in Sigma-Delta DAC & a headphone driver to directly drive low impedance headphones. The ADC includes inputs for both Microphone and Analog Audio in to support voice recording and FM radio integration features. Thus, the ATJ2085 provides a true 'ALL-IN-ONE' solution that is ideally suited for highly optimized digital audio players with mass storage function.

## 2. Features

- MPEG1/2/2.5 Audio Layer 1, 2, 3 decoder
- Support WMA Decoder
- Digital Voice Recording with Actions Speech Algorithm
- 24 bits DSP Core with memory and on-chip Debug Support Unit (DSU)
- Integrated 8-bit MCU with DSU
- External up to 2(cs) x 64M/128M/256M/512M/1G/2G bytes Nand type Flash accessed by MCU or DMA
- Built-in DMA, CTC (Counter/Timer Controller) and interrupt controller for MCU
- Energy saving dynamic power management (PMU)
- Support USB 2.0 ( FS ) , Write speed(Max): 955k byte/s; Read speed(Max): 1033k byte/s
- Build in Stereo 18-bit Sigma-Delta DAC
- Build in Key Scan Circuit (3\*3) and GPIO
- I<sup>2</sup>C interface supports Master/Slave mode, with changeable slave address
- Support external 8080 Interface LCM driver
- Support FM Radio input and 32 levels volume control
- Support Stereo 16-bit Sigma-Delta ADC for Microphone/FM Input, sample rate at

8/12/16/22/24/32/48KHz

- MCU run at 24.576MHz(TYP), up to 60MHz
- SNR: 90dB (DAC TYP)
- Headphone driver output 2x11mW @16 Ohm(TYP)
- Operating Voltage: IO: 3.0V(TYP), Core: 2.0V(TYP)
- Standby Leakage Current: VCC: 35uA@3.0V(TYP) , VDD: 110uA@2.0V(TYP)
- Low Power Consumption, designed for greater than 15 (TYP) hours of operation on a single battery life. (<65mW at typical MP3 decoder solution; <90mW at typical WMA decoder solution)
- 64-pin (10x10mm) LQFP package



### 3. Pin Description

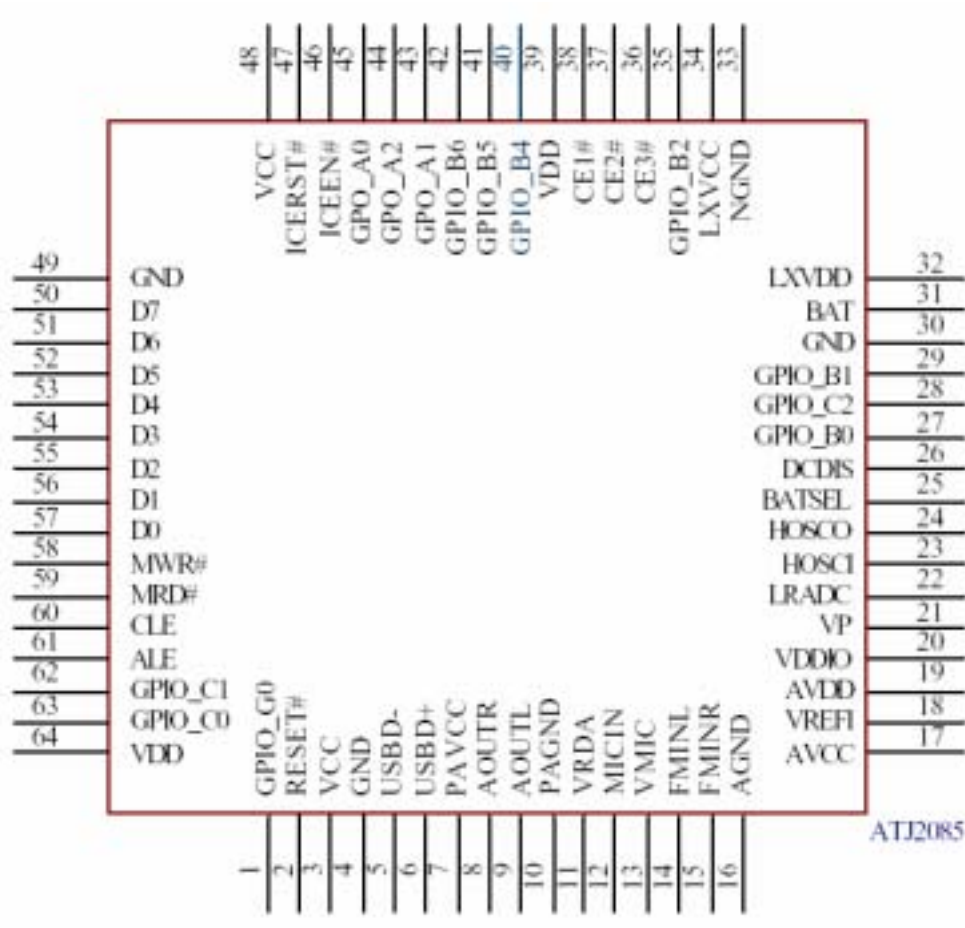

#### 3.1 Pin Sort by Number

Pin No.	Pin Name	I/O Type	Driver	Reset Default	Short Description
1	GPIO_G0	BI	1.9mA Driver	Z	Bit0 of General purpose I/O port G
2	RESET-	I	SCU	H	System reset input (active low)
3	VCC	PWR	/	/	Digital power
4	GND	PWR	/	/	Digital ground
5	USB-	A	/	H	USB data minus
6	USB+	A	/	H	USB data plus
7	PAVCC	PWR	/	/	Power supply for power amplifier(two bypass

					capacitors are 47uF and 0.1uF)
8	AOUTR	AO	/	/	Int. DAC right channel analog output
9	AOUTL	AO	/	/	Int. DAC left channel analog output
10	PAGND	PWR	/	/	Power amplifier ground
11	VRDA	AO	/	/	Bypass capacitor (typ 0.47uF)
12	MICIN	AI	/	/	Microphone pre-amplifier input (0.8V-2.2V)
13	VMIC	AO	/	/	Power supply for microphone, 2.2V output
14	FMINL	AI	/	/	Left channel of FM line input
15	FMINR	AI	/	/	Right channel of FM line input
16	AGND	PWR	/	/	Analog ground
17	AVCC	PWR	/	/	Analog power
18	VREFI	AI	/	/	Voltage reference input (1.5V)
19	AVDD	PWR	/	/	Analog power
20	VDDIO	PWR	/	/	Power output (connect to VDD through a 4.7 Ohm (typ) resistance)
21	VP	PWR	/	/	Power pin (When 2 Batteries mode, connect to BAT. Others mode Connect to VCC)
22	LRADC	AI	/	/	Low resolution ADC input, 0.8--2.2V, 8Bit ADC
23	HOSCI	AI	/	/	High frequency crystal OSC input
24	HOSCO	AO	/	/	High frequency crystal OSC output
25	BATSEL	I	/	/	Battery select. L : One Battery H : Two Batteries
26	DCDIS	I	/	L	Int. DC-DC control pin. H: Disable DC-DC. L: Enable DC-DC.
27	GPIO_B0	BI	1.9mA	Z	Bit0 of General purpose I/O port B
	KEYI0	I	Driver	/	Bit0 of key scan circuit input
28	GPIO_C2	BI	1.9mA Driver	L	Bit2 of General purpose I/O port C
29	GPIO_B1	BI	1.9mA	Z	Bit1 of General purpose I/O port B
	KEYI1	I	Driver	/	Bit1 of key scan circuit input
30	GND	PWR	/	/	Ground
31	BAT	AI	/	/	Battery monitor pin
32	LXVDD	AO	/	/	VDD DC-DC pin



33	NGND	PWR	/	/	NMOS ground
34	LXVCC	AO	/	/	VCC DC-DC pin
35	GPIO_B2	BI	1.9mA	Z	Bit2 of General purpose I/O port B
	KEYI2	I	Driver	/	Bit2 of key scan circuit input
36	CE3-	O	/	H	8080 interface LCM chip enable
37	CE2-	O	/	H	Nand Flash chip enable (optional)
38	CE1-	O	/	H	Boot up Nand Flash chip enable (must be connected to Nand Flash)
39	VDD	PWR	/	/	Digital power
40	GPIO_B4	BI	1.9mA	Z	Bit4 of General purpose I/O port B
	KEYO0	O	Driver	/	Bit0 of key scan circuit output
41	GPIO_B5	BI	1.9mA	Z	Bit5 of General purpose I/O port B
	KEYO1	O	Driver	/	Bit1 of key scan circuit output
42	GPIO_B6	BI	1.9mA	Z	Bit6 of General purpose I/O port B
	KEYO2	O	Driver	/	Bit2 of key scan circuit output
43	GPO_A1	O	3.5mA	L	Bit1 of General purpose output port A
	ICECK	I	Driver	/	Clock input to DSU for debug
44	GPO_A2	O	3.5mA	Z	Bit2 of General purpose output port A
	ICEDO	O	Driver	/	Data output from DSU for debug
45	GPO_A0	O	3.5mA	H	Bit0 of General purpose output port A
	ICEDI	I	Driver	/	Data input to DSU for debug
46	ICEEN-	I	SCU	H	DSU enable (active low)
47	ICERST-	I	SCU	H	DSU reset (active low)
48	VCC	PWR	/	/	Digital power
49	GND	PWR	/	/	Ground
50	D7	BI	/	L	Bit7 of ext. memory data bus
51	D6	BI	/	L	Bit6 of ext. memory data bus
52	D5	BI	/	L	Bit5 of ext. memory data bus
53	D4	BI	/	L	Bit4 of ext. memory data bus
54	D3	BI	/	L	Bit3 of ext. memory data bus
55	D2	BI	/	L	Bit2 of ext. memory data bus
56	D1	BI	/	L	Bit1 of ext. memory data bus
57	D0	BI	/	L	Bit0 of ext. memory data bus

58	MWR-	O	/	H	Ext. memory write strobe
59	MRD-	O	/	H	Ext. memory read strobe
60	CLE	O	/	L	Command latch enable for NAND type flash
61	ALE	O	/	L	Address latch enable for NAND type flash
62	GPIO_C1	BI	1.9mA Driver	H	Bit1 of General purpose I/O port C
	I <sup>2</sup> C_SDA	BI		/	I <sup>2</sup> C Serial data (Open drain)
	SIRQ-	I		/	Ext. interrupt request input
63	GPIO_C0	BI	1.9mA Driver	H	Bit0 of General purpose I/O port C
	I <sup>2</sup> C_SCL	BI		/	I <sup>2</sup> C serial clock (Open drain)
64	VDD	PWR	/	/	Digital power

## Notes:

- 1: PWR----Power Supply      2: AI----Analog Input      3: AO----Analog Output  
4: O----Output                5: I----Input                6: BI----Bi-direction  
7: SCU----SCHIMITCU

## 4. Function Description

### 4.1 Functional Block Diagram

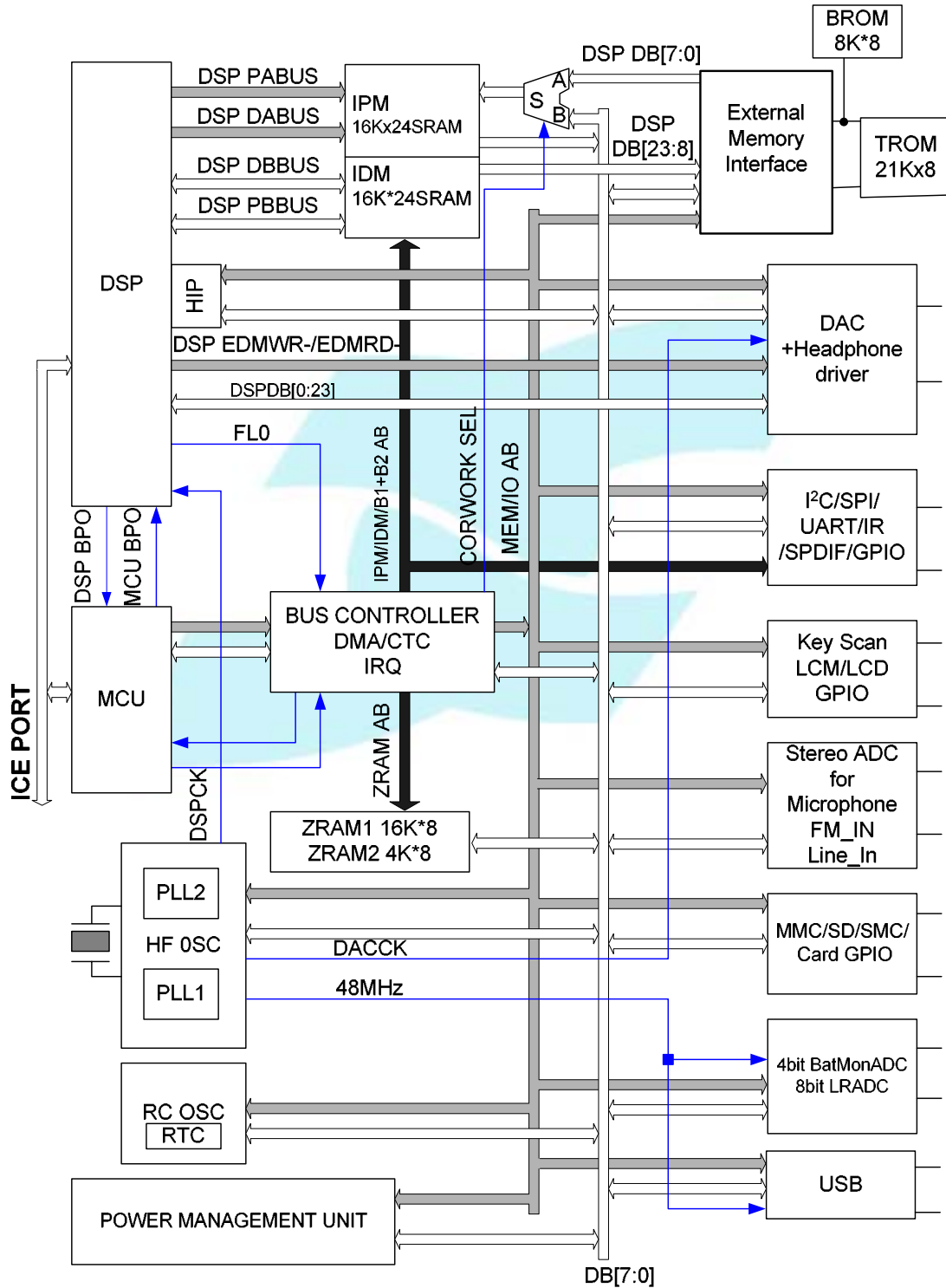

### 4.2 MCU Core

ATJ2085 integrates 8-bit MCU with on-chip ICE support. Instruction set is compatible with Z80. Process capability is controlled by software Up to 60 MHz.

ATJ2085 includes 116 Kbytes of on-chip SRAM and 29Kbytes on-chip ROM. See the following flag for on chip memory mapping.

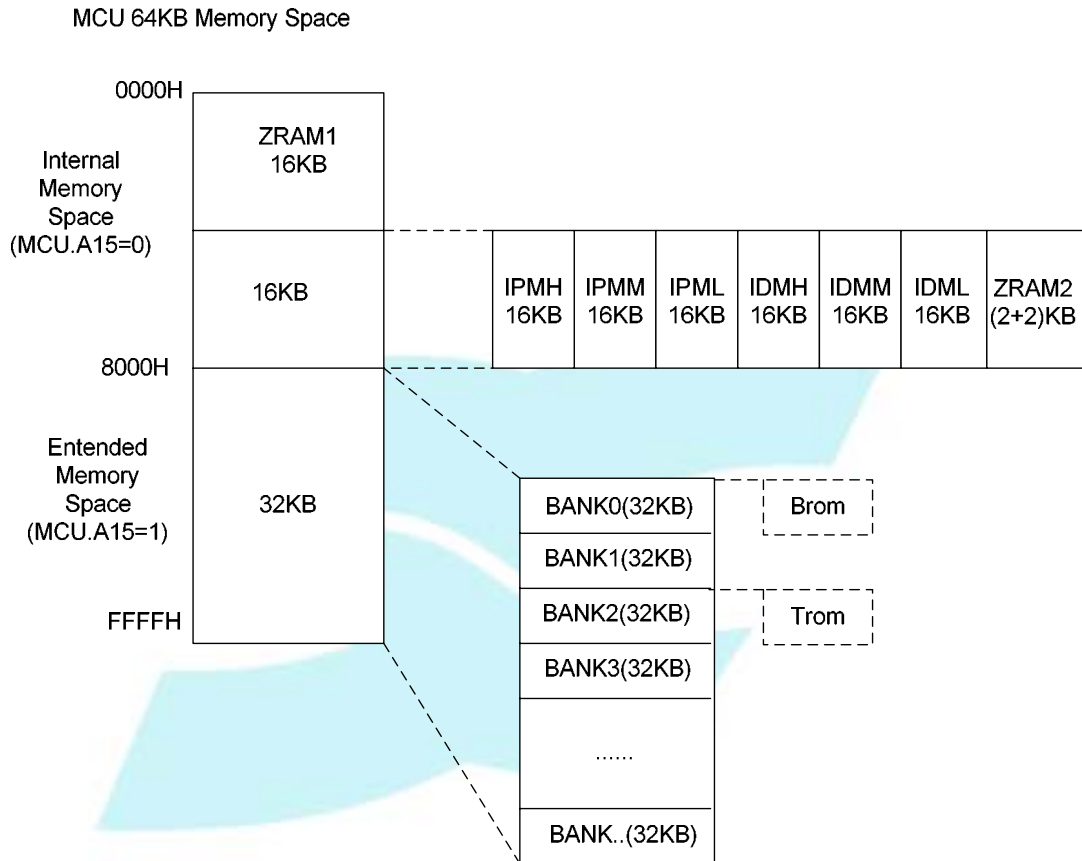

### 4.3 DSP Core

24-bit Harvard architecture DSP with on-chip ICE support is built in. It works with a memory word length of 24 bits. ATJ2085 has 16KB\*24bit Program Memory (PM) and (16KB-256)\*24bit Data Memory (DM). Memory-Mapped Register includes DAC interface. Process capability is controlled by software Up to 72 MIPS.

### 4.4 DMA Controller

ATJ2085 supports 3 kinds of DMA channels. DMA1/2 support Data exchange in Memory or IO. The last DMA is USB DMA.

### 4.5 General Purpose IO Ports

ATJ2085 has GPOA, GPIOB, GPIOC, and GPIOG. They have different functions in different modes.

Function		F1 (Default)	F2 (Function 2)
GPIO			
GPOA	0	When ICE is used, GPO_A[2~0] Pins are ICEDO, ICECK and ICEDI; Otherwise GPO_A[2~0] is used for output function.	
	1		
	2		
GPIOB	0	When choosing Keyboard function, GPIOB[2~0] Pins are KEYI[2~0], and GPIOB[6~4] are KEYO[2~0]; when not choosing Keyboard function, as GPIOB[6-4:2-0] ; When keyboard function enables, while some Key in [2~0] is used as GPIOB, the relative Key in should be masked.	
	1		
	2		
	4		
	5		
	6		
GPIOC	0		When I2C function enables, it is used as I2C_SCL. When as IO, it is GPIO_C0, then I2C can not be enabled simultaneously
	1	Only used as GPIOC [3~0]	When I2C function enables, it is used as I2C_SDA. When external interrupt enables, it is SIRQ-; and when as IO, it is GPIO_C, multiple functions can not be enabled simultaneously.
			when as IO, it is GPIO_C2
2			
GPIOG	0	GPIOG[0]	

## 4.6 RTC/CTC/Watch Dog Timer

RTC is a 24-bit counter with the following function:

- Time
- Alarm
- Timer

CTC is a counter whose clock source is different with RTC's.

Watchdog can be set from 176-milisecond to 180-second with different step.

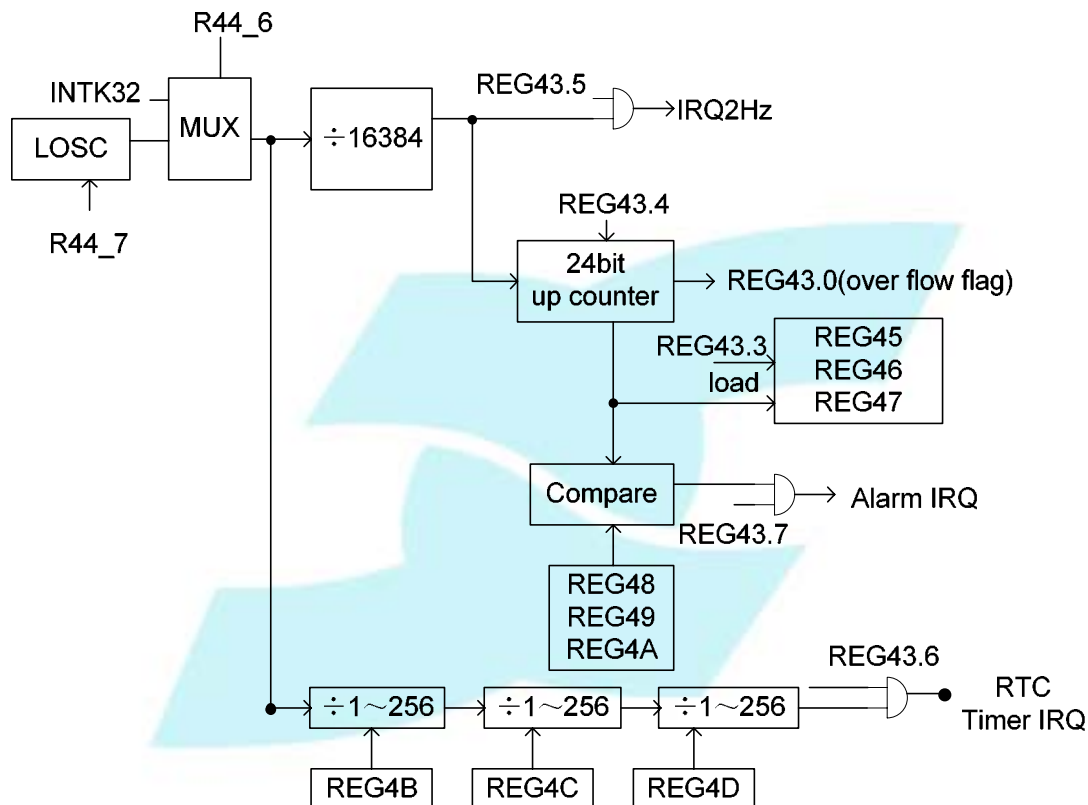

## 4.7 Oscillator/PLL

ATJ2085 supports 24.576MHz crystal, which is the system clock source.

A low jitter PLL referenced to 24.576MHz is used to generate clock for DSP and for serial communication protocols such as USB, UART, etc. The clock used in serial communications is 48MHz so the PLL generates frequency at multiple of 48MHz to support DSP and serial communication simultaneously. Another PLL referenced to 24.576MHz is used to generate 22.5792MHz for sample rate 44.1K/22.05KHz/11.025KHz.

**PLL1 DIAGRAM**

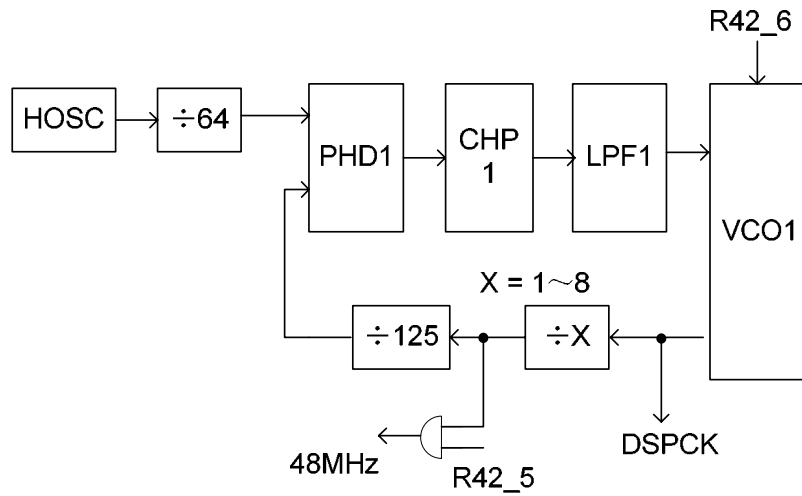

**PLL2 DIAGRAM**

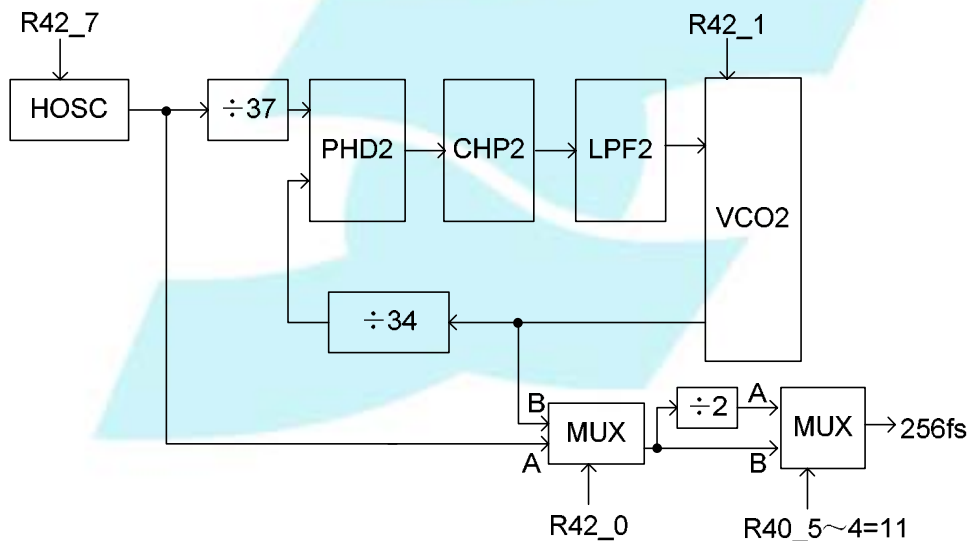

**4.8 Power Management Unit (PMU)**

PMU consists of DC-DC converter, regulator and battery monitor.

In ATJ2085, there are two DC/DC converters and one liner regulator. One DC/DC converter is for VCC power supply and another is for VDD. The liner regulator is for VDD power supply when two battery mode or other conditions where need less external components.

In ATJ2085, the default value of VCC is 3.0V and VDD is 2.0V. The regulator's default output is 2.0V; all three values can be controlled by Registers. The VCC is from 2.8V to 3.3V; VDD is from 1.6V to 2.3V; the regulator is the same as VDD.

ATJ2085 supports one-battery mode, two-battery mode, USB power supply or DC power line-in.

There are two pins for mode configurations. One is “DCDIS”; the other is “BATSEL”, the truth table as follow:

DCDIS	BATSEL	DC/DC1(VDD)	DC/DC2(VCC)	Regulator	Mode descriptions
0	0	Yes	Yes	No	One battery with more external components, but more efficiency
0	1	No	Yes	Yes	Two battery
1	0	No	Yes	Yes	One battery with less external components, but less efficiency
1	1	No	No	Yes	USB power or DC power line-in

The pin of “DCDIS” has an on-chip pull down resistor. There is a built-in super low speed and low resolution ADC for battery monitor in ATJ2085. The level of minimum battery voltage warning can be configured by registers; the range is from 0.98V to 1.22V. The voltage level of resetting system can be controlled by register; the range is from 0.9V to 1.14V.

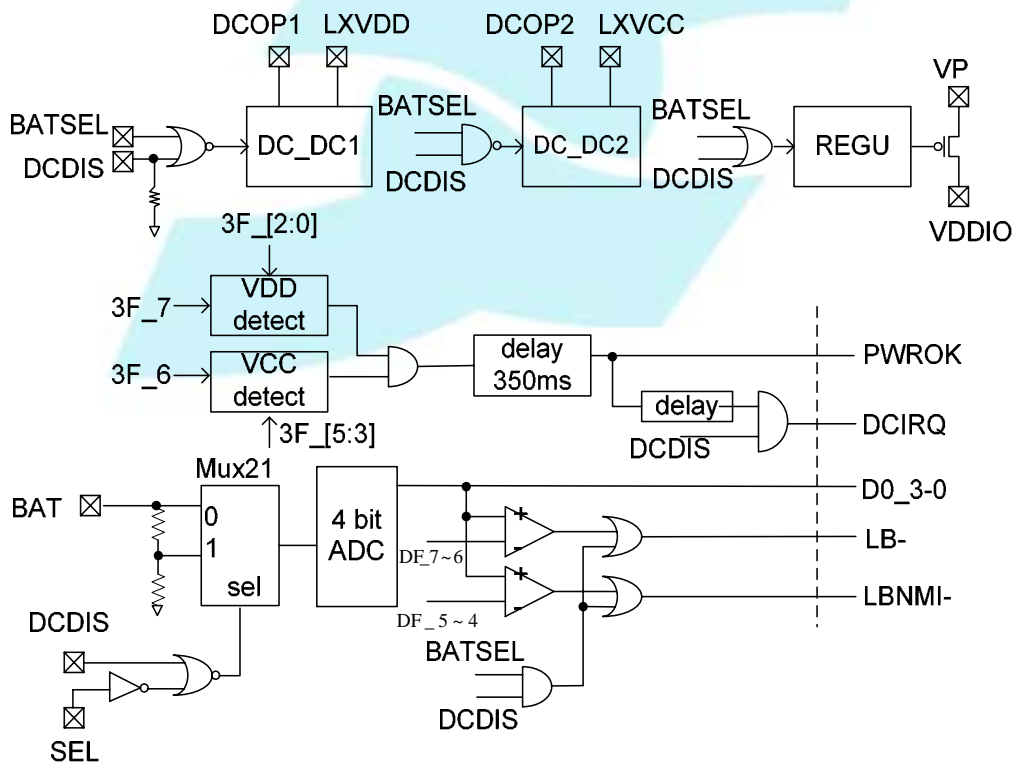

### 4.9 ADC

There are 3 Analog-to-Digital Converters integrated in ATJ2085: 16-bit  $\Sigma$ - $\Delta$  ADC is for MIC/FM Input/Line Input, 8-bit SAR ADC for Line Controller, and 4-bit ADC for Battery Monitor



The internal microphone amplifier has gain for recording. The VMIC pin is the power supply (2.2V) for microphone.

The audio ADC is an 18 bits sigma delta Analog-to-Digital Converter. Its input source can be selected from MIC amplifier or external FM or line-in, and it has two FIFO.

ATJ2085 has an 8-bit switched-capacitor SAR Analog-to-Digital Converter (SARADC). Its input source is LRADC pin ( for remote control ) , input range is 0.8-2.2V, and its FS can be 8K, 4K, 2K, 1K. In remote control , only the most significant 8 bits are used.

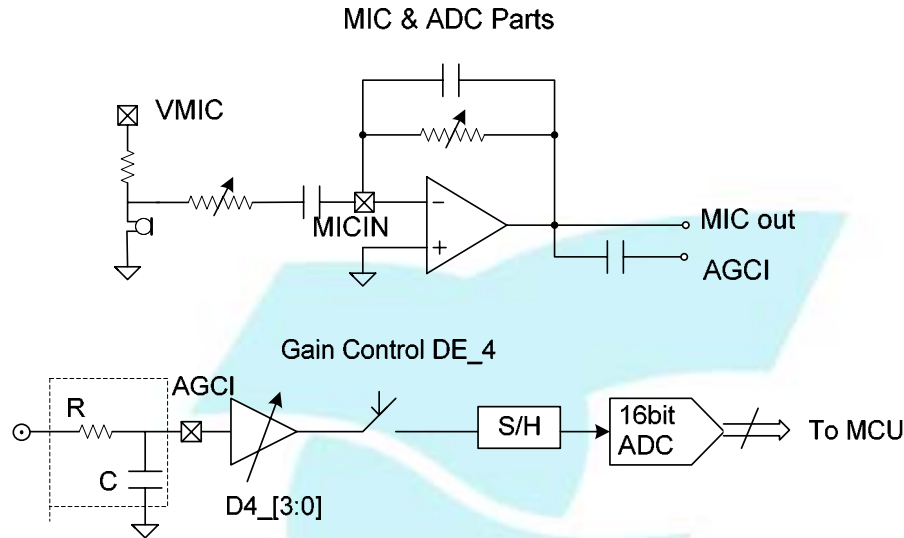

**4.10 DAC**

ATJ2085's DAC3 is an on-chip Sigma-Delta Modulator, composed by a high performance DAC. And the DAC analog block refers to the following diagram. The DAC interface supports 4-level play back FIFO (8 x 20-bit PCM data for L/R channel) and variable sample rates, such as 48K/ 44.1K / 32K/ 24K/ 22.05K/ 16K/ 12K/ 11.025K/ 8KHz. An on-chip PLL2 is used to generate 22.5792MHz from 24.576MHz to support 44.1K/2 2.05 K/ 11.025KHz with 256xFS clock for over-sampling, while 24.576MHz supports 48K/ 32K/ 24K/ 16K/ 12K/ 8KHz with 256XFS for over-sampling.

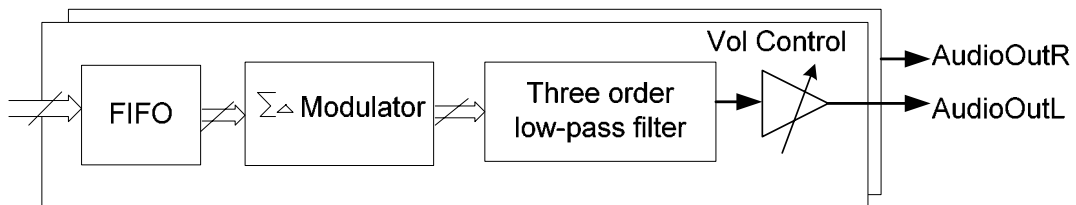

### 4.11 Headphone Driver

The output power of ATJ2085's amplifier is 13mW(each channel).

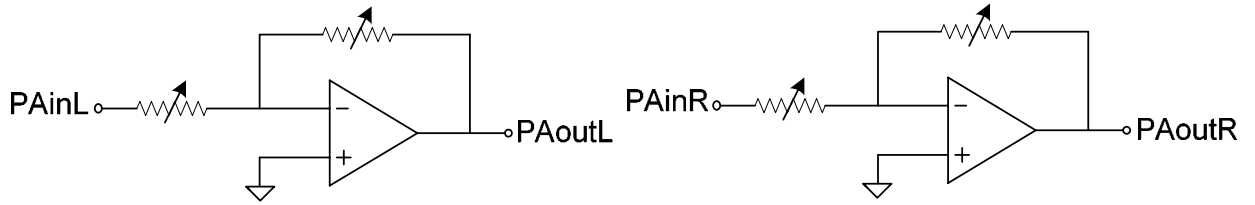

### 4.12 Key Scan Interface

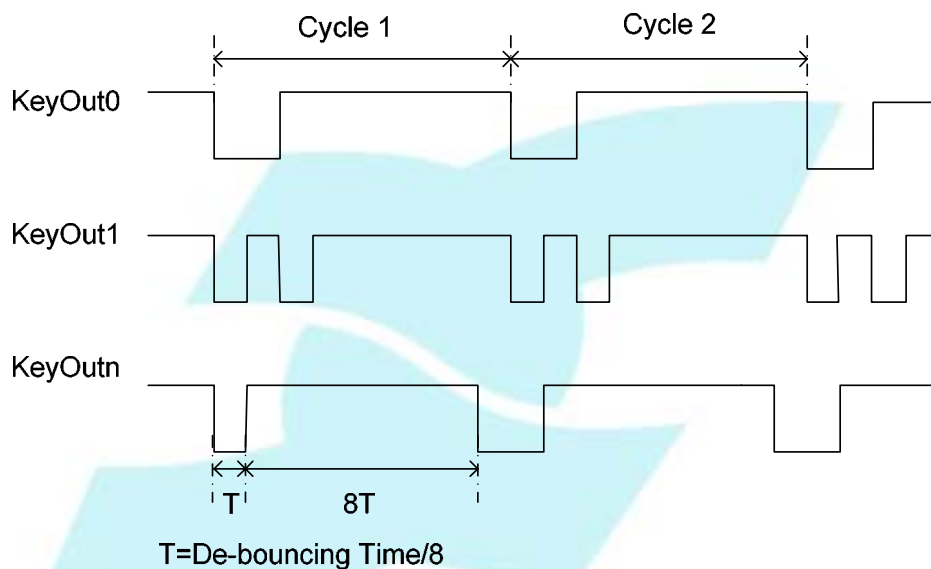

**Key Scan Timing**

When key scan circuit is enabled, ATJ2085 will scan the keyboard periodically. It drives pin Key out N scan pulse in turn. When any key is pressed, the corresponding Key out N will send out the scan pulse. When a key is pressed, pin Key in N connecting the key will be found low level.

There are 12 internal 8-bit registers for key value latch per scan. But only another one register (Key Scan Data Register) for MCU may access key value. Those 12 internal registers are mapped into this register, and an internal pointer is used to point to the current register to return scan data when read. Any IO write to this register will clear the internal register, and the pointer will increase by 1 and point to the next register after read is performed.

### 4.13 External Memory Interface

ATJ2085 can support NAND type flash from 32M to 1G bytes.

See the following for NAND flash Read/Write timing.

**Read:**

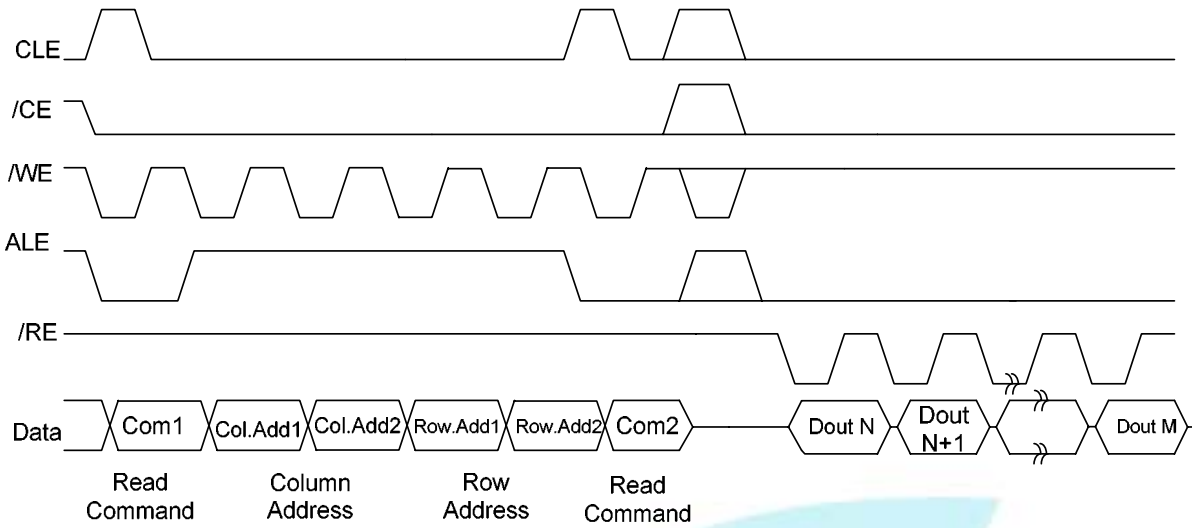

Nand Flash Read timing

**Write:**

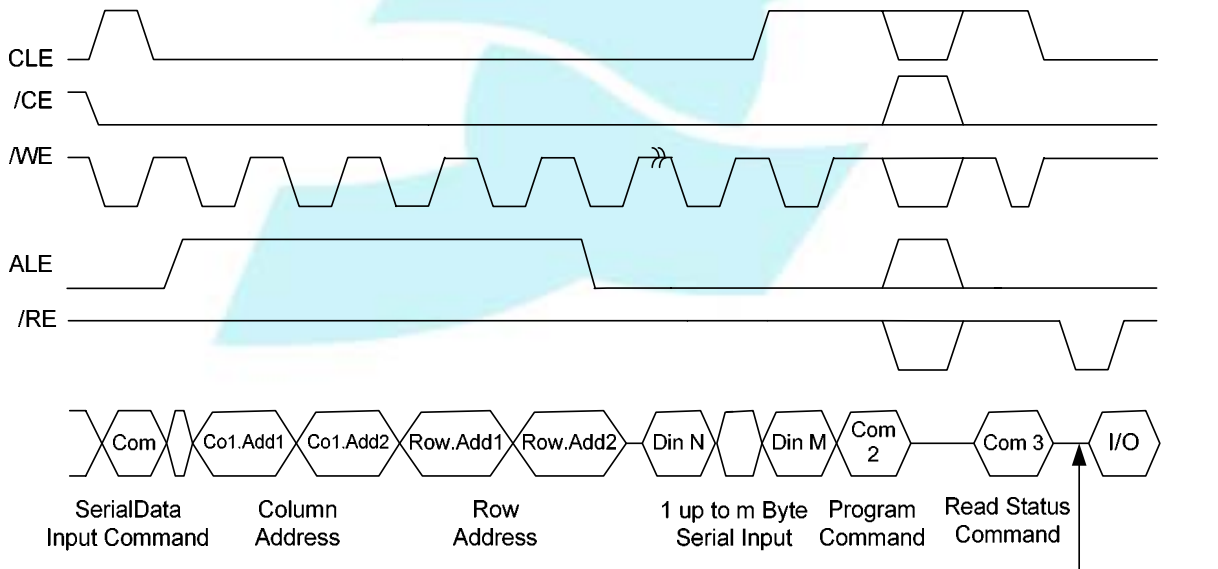

Nand Flash Program timing

I/O.=0 Successful Program  
I/O.=1 Error in Program

**4.14 I2C Interface**

ATJ2085's I2C can be configured as either a master or slave device. In master mode it generates the clock (I2C\_SCL) and initiates transactions on the data line (I2C\_SDA). Data on the I2C bus is byte oriented. Multi-Master mode, 10-bit address and Hi-speed mode are not supported. See the I2C\_Bus\_Specification\_1995 for detailed information.

### I<sup>2</sup>C Interface Timing

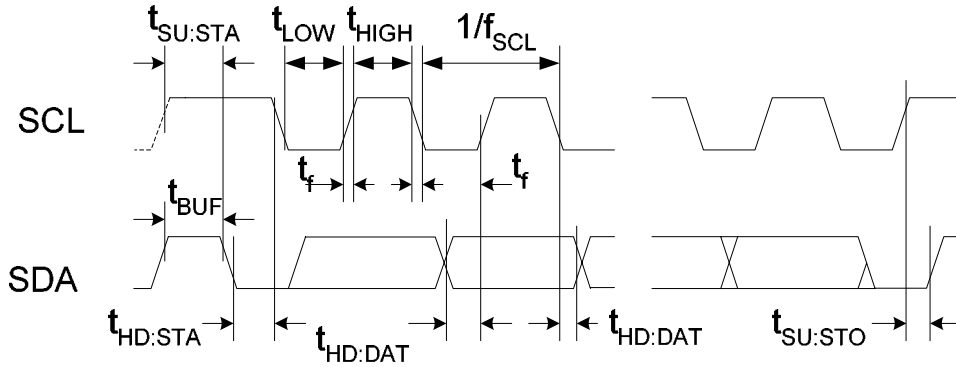

Parameter	Symbol	Typical	Unit
SCL period	$f_{SCL}$	100	KHZ
Clock low time	$t_{LOW}$	5	us
Clock high time	$t_{HIGH}$	4.5	us
Clock rise time	$t_r$	500	ns
Clock fall time	$t_f$	20	ns
data setup time	$t_{SU:DAT}$	4.5	us
data hold time	$t_{HD:DAT}$	50	ns

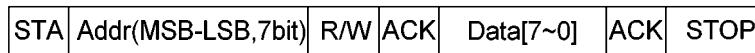
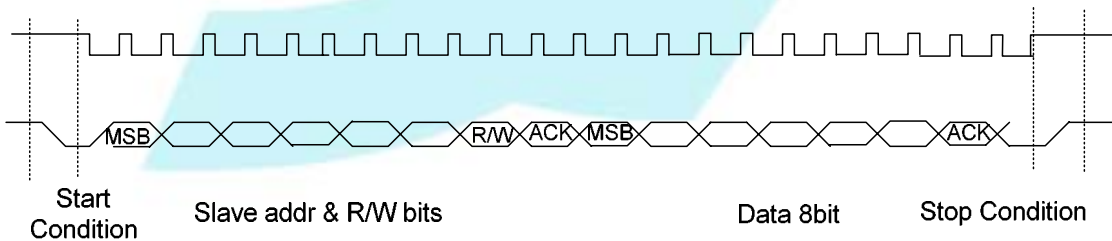

### I<sup>2</sup>C Timing and Format

#### 4.15 USB 2.0(FS) SIE

Communications with the host can be made via speed-programmable USB interface (compliant with USB SPEC 2.0 (FS)). Such communications, including file downloading or uploading, audio/video data transferring, etc., depend on different implementations to meet different requirements. 4 endpoints are provided. Endpoint 1 and endpoint 2 are capable of isochronous transfer mode, and in this case, the maximum packet size can be 1023, according to USB SPEC.

These two endpoints employ two independent FIFO for bulk or isochronous transfers. Endpoint 0 and endpoint 3 have 8 bytes maximum packet size. There are 4 interrupt requests for each endpoint respectively. Generally, this setting should be satisfying for most practical needs.

#### 4.15.1 Hard Core

The USB block includes a USB function with one upstream port. The USB port interfaces to the micro-controller through a programmable-speed serial interface engine (SIE). The SIE allows the micro-controller to communicate with the USB host.

#### 4.15.2 Interrupts

Two groups of interrupt requests are used to notify the micro-controller that there is some USB event pending to be handled. One is Global Interrupt group, and the other is Endpoint Interrupt group. Whenever an interrupt is generated, the SIE will send a low pulse to the micro-controller. The IRQ will not be invalidated until all the pending interrupts are cleared.

#### 4.16 FM Interface

ATJ2085 can be used as a controller with Philips FM5767 module. 2-wire or 3-wire also can be used to control the module.

### 5. Electrical Characteristics

#### 5.1 Absolute Maximum Ratings

Parameter	Symbol	Typical	Rating	Unit
Supply voltage	VDD	2.0V	-0.5 to +2.7	V
	VCC	3.0V	-0.5 to +3.6	V
Input voltage	Vi	VCC >= 3.3	-0.5 to +3.9	V
		VCC < 3.3	-0.5 to VCC+0.6	V
Storage temperature	T <sub>stg</sub>		-65 to +150	

Note:

1. TO = 25 (Operating Temperature)
2. Do not short-circuit two or more output pins simultaneously.
3. If even one of the above parameters exceeds the absolute maximum ratings even momentarily, the quality of the product may be degraded. The absolute maximum ratings, therefore, specify

the value exceeding which the product may be physically damaged. Use the product well within these ratings.

4. The specifications and conditions shown in DC Characteristics and AC characteristics are the ranges for normal operation and quality assurance of the product.

## 5.2 Capacitance

Parameter	Symbol	Condition	MIN.	MAX.	Unit
Input capacitance	$C_I$	$f_C = 1 \text{ MHz}$		15	pF
I/O capacitance	$C_{IO}$	Unmeasured pins returned to 0 V		15	pF

Note:  $T_O = 25$  ,  $V_{CC} = 0 \text{ V}$ .

## 5.3 DC Characteristics

Parameter	Symbol	Condition	MIN.	TYP.	MAX	Unit
High-level output voltage	$V_{OH}$	$I_{OH} = -2 \text{ mA}$	2.4	/	/	V
Low-level output voltage	$V_{OL}$	$I_{OL} = 2 \text{ mA}$	/	/	0.4	V
High-level input voltage	$V_{IH}$	/	$0.7 \cdot V_{CC}$	/	$V_{CC} + 0.6$	V
Low-level input voltage	$V_{IL}$	/	-0.3	/	$0.4V_{CC}$	V
Input leakage current	$I_{LI}$	$V_{CC} = 3.6 \text{ V}, V_I = V_{CC}, 0 \text{ V}$	/	/	$\pm 10$	$\mu\text{A}$
Output leakage current	$I_{LO}$	$V_{CC} = 3.6 \text{ V}, V_I = V_{CC}, 0 \text{ V}$	/	/	$\pm 5$	$\mu\text{A}$
GPIO Drive	$I_{drive1}$	GPOA0,GPOA1,GPOA2	/	2.60	/	mA
	$I_{drive2}$	Other GPIO	/	1.25	/	mA
Supply Current (Two battery mode)	$I_{VDD}$	In Full speed mode (MCU run 24.576MHz in internal SRAM, DSP run 36MIPS)	/	40	60	mA
		In Standby mode	50	110	350	$\mu\text{A}$
	$I_{VCC}$	In Full speed mode (MCU run 24.576MHz in internal SRAM, DSP run 36MIPS)	9	16	40	mA
		In Standby mode	25	35	70	$\mu\text{A}$

Notes :

1.  $T_A = -10$  to  $+70$  ,  $V_{DD} = 2.0$  V,  $V_{CC} = 3.0$  V
2.  $I_{VDD}$  is the total power supply current for 2.0 V power supply.  $I_{VDD}$  is applied to the LOGIC, PLL and OSC blocks.
3.  $I_{VCC}$  is the total power supply current for 3.0 V power supply.  $I_{VCC}$  is applied to the USB, IO, TP and AD blocks.

**5.4 AC Characteristics ( $T_A = -10$  to  $+70$  ,  $V_{DD} = 1.8$  to  $2.7$  V,  $V_{CC} = 2.7$  to  $3.6$  V)**

**5.4.1 AC test input waveform**

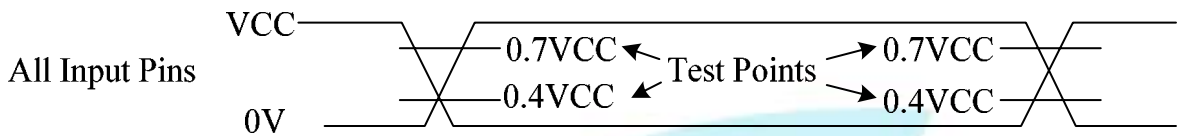

**5.4.2 AC test output measuring points**

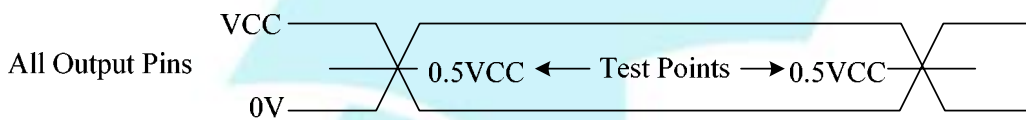

**5.4.3 Reset Parameter**

Parameter	Symbol	Condition	MIN.	MAX.	Unit
Reset input low-level width	$t_{WRSL}$	RESET# pin	160		us

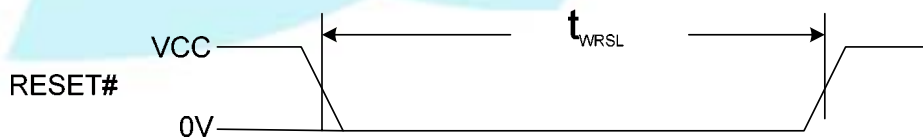

**5.4.4 Initialization Parameter**

Parameter	Symbol	Condition	MIN.	MAX.	Unit
Data sampling time (from RESET#)	$t_{SS}$			61.04	us
Output delay time (from RESET# )	$t_{OD}$		61.04		us

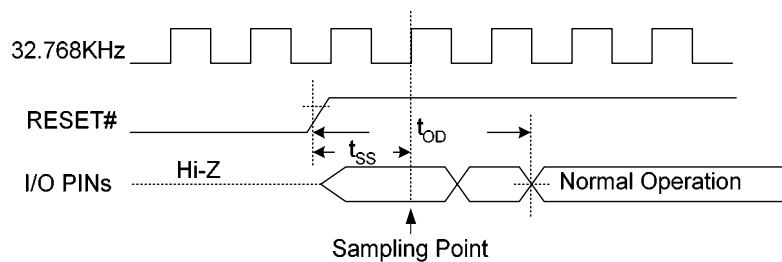

5.4.5 GPIO Interface Parameter

Parameter	Symbol	Condition	MIN.	MAX.	Unit
Input level width	$t_{GPIIN}$	Normal operation	$11/f_{MCUCLK}$		s
GPIO input rise time	$t_{GPRISE}$			200	ns
GPIO input fall time	$t_{GPFALL}$			200	ns
Output level width	$t_{GPOUT}$		$11/f_{MCUCLK}$		s

Notes:  $f_{MCUclk}$  is the frequency that MCU is running upon.

Input level width



Input rise/fall time



Output level width



5.4.6 Ordinary ROM Parameter

Parameter	Symbol	Condition	MIN.	MAX.	Unit
Data access time (from address) <sup>Note</sup>	$t_{ACC}$	HOSC=24.576MHz	102		ns
Data access time (from CE#) <sup>Note</sup>	$t_{CE}$	HOSC=24.576MHz	82		ns
Data input setup time	$t_{DS}$	HOSC=24.576MHz	0		ns
Data input hold time	$t_{DH}$	HOSC=24.576MHz	0		ns



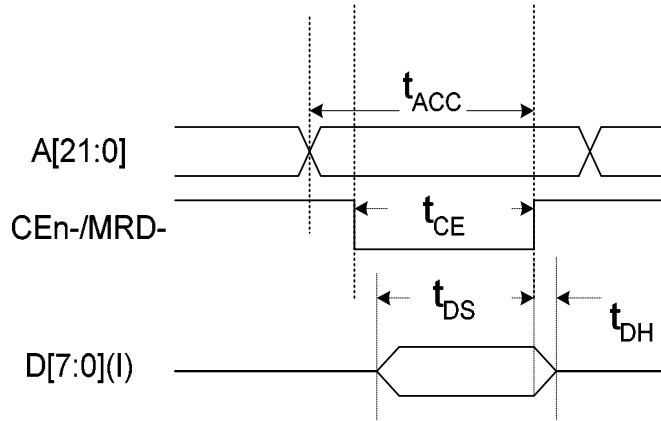

5.4.7 External System Bus Parameter

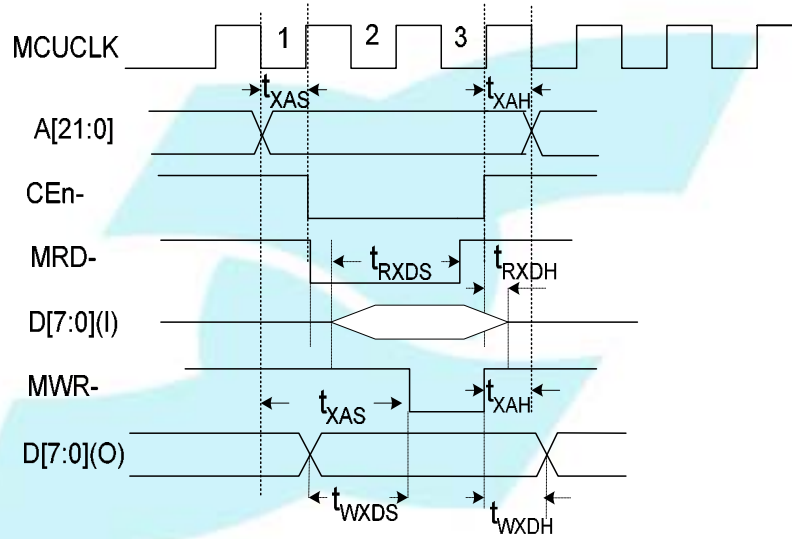

Parameter	Symbol	Condition	MIN.	MAX.	Unit
Address setup time (to command signal) <sup>Note 1, 2</sup>	t <sub>XAS</sub>	Memory Read	0.5T		ns
	t <sub>XAS</sub>	Memory Write	1.5T		ns
Address hold time (from command signal) <sup>Note 1, 2</sup>	t <sub>XAH</sub>		0.5T		ns
Data output setup time (to command signal) <sup>Note 1</sup>	t <sub>WXDS</sub>		0	T	ns
Data output hold time (from command signal) <sup>Note 1</sup>	t <sub>WXDH</sub>		3	0.5T	ns
Data input setup time (to command signal) <sup>Note 1</sup>	t <sub>RXDS</sub>		0	2T	ns
Data input hold time (from command signal) <sup>Note 1</sup>	t <sub>RXDH</sub>		0		ns

Notes: 1. MRD#, MWR# are called the command signals for the External System Bus Interface.

2. T (ns) = 1 / f<sub>MCUCLK</sub>

5.4.8 Bus Operation

Instruction Fetch Timing

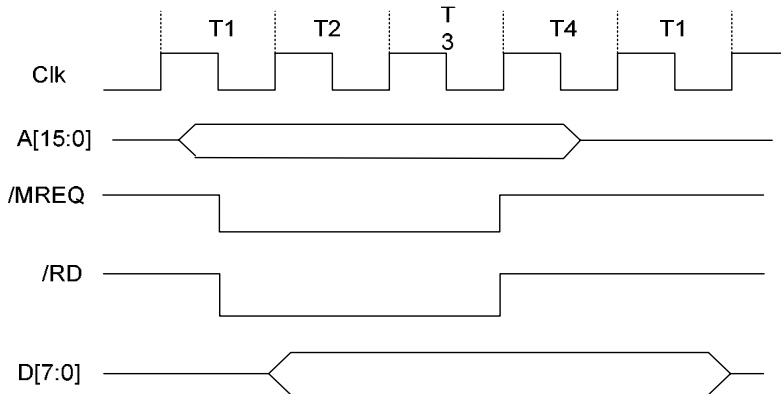

Instruction Fetch Timing

Memory Read Timing

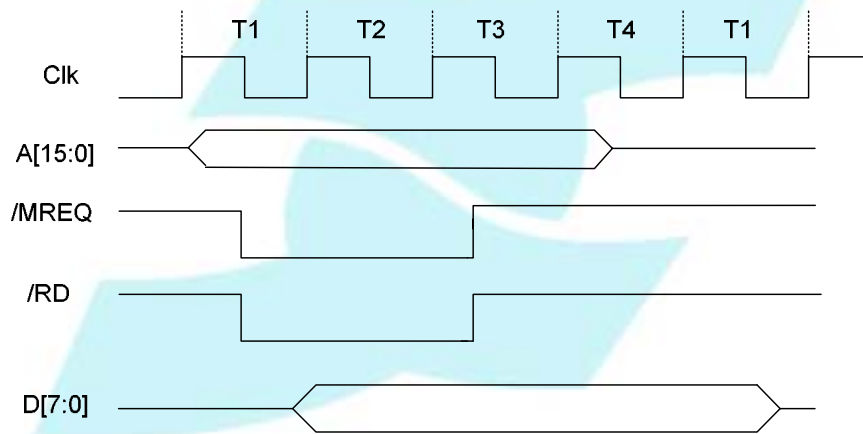

Memory Read Timing

Memory Write Timing

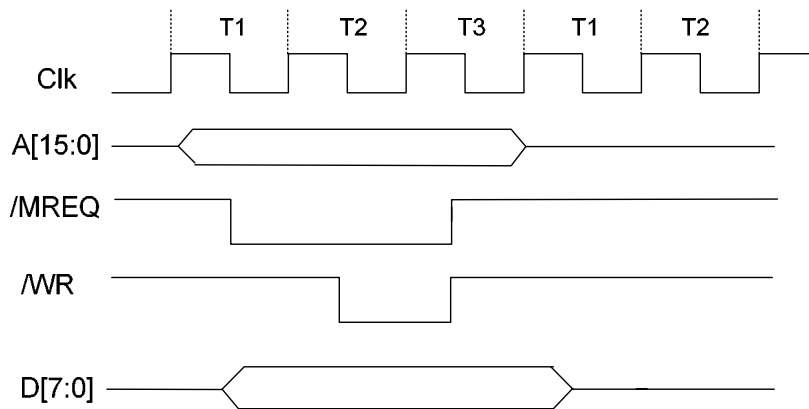

Memory Write Timing

IO Read Timing

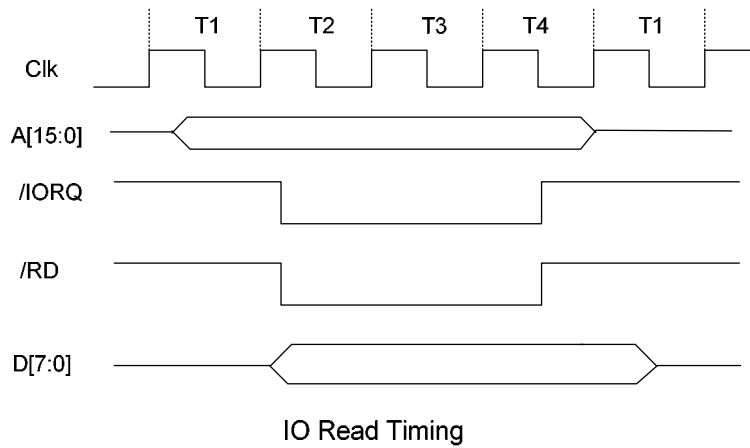

IO Read Timing

IO Write Timing

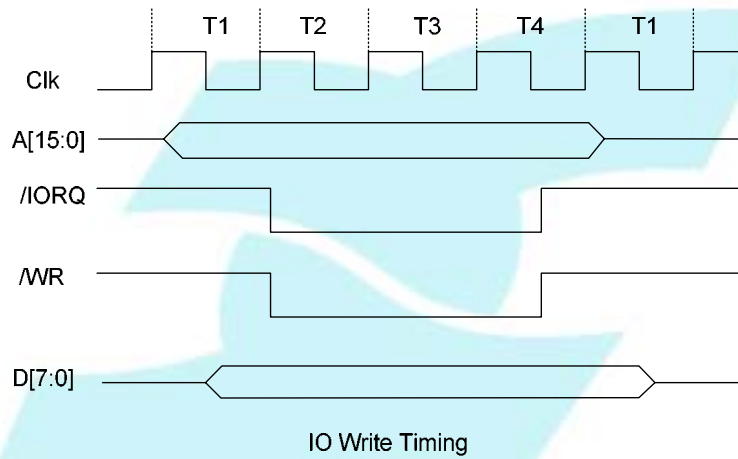

IO Write Timing

DMA1/2 Timing

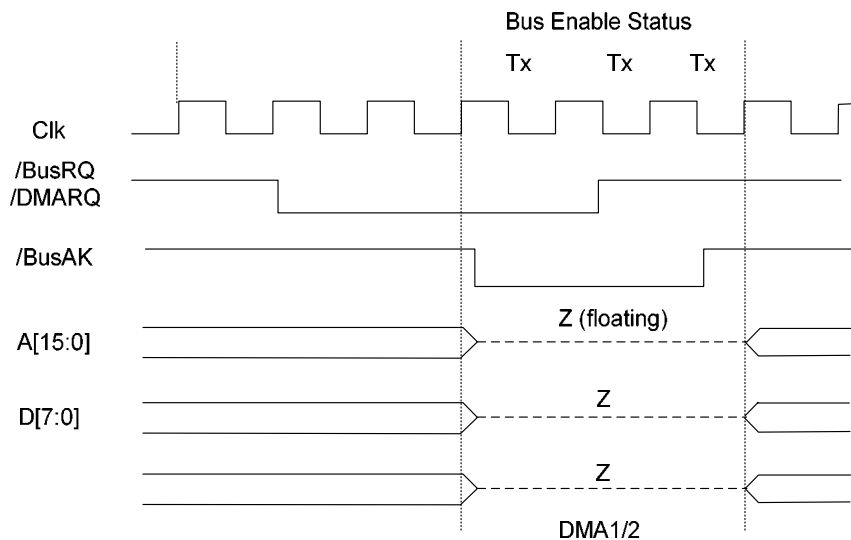

DMA1/2 Timing

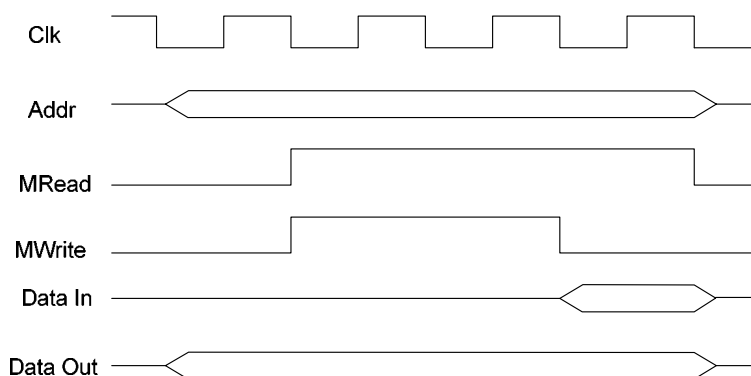
**DSP Read/Write Timing**

DSP Read/Write Timing

**5.4.9 A/D Converter Characteristics**

( $T_A = -10 \sim +70$  ,  $V_{DD} = 2.0$  V,  $V_{CC} = 3.0$ V, Sample Rate=32KHz)

Characteristics	Min	Typ.	Max	Unit
Dynamic range		60		dB
Total Harmonic Distortion + Noise	50	53	55	dB
Frequency Response (20-13KHz)			$\pm 1$	dB
Full Scale Input Voltage(Gain=0dB)		800		mVpp

Note: 1.  $T_A = -10$  to  $+70$  ,  $V_{DD} = 2.0$  V,  $V_{CC} = 3.0$ V.

2. Sample Rate=32 KHz

**5.4.10 Headphone Driver Characteristics Table**

Characteristics	Min	Typ	Max	Unit
Dynamic Range -60 dBFS Input		87		dB
Total Harmonic Distortion + Noise	70	73	75	dB
Frequency Response 20-20KHz			$\pm 0.6$	dB
Output Common Mode Voltage		1.5		V
Full Scale Output Voltage		1.6	2.4	Vpp
Inter channel Isolation (1KHz)		91		dB
Inter channel Gain Mismatch(1KHz)		0.025		dB

Note:1.  $T_A = -10 \sim +70$  ,  $V_{DD} = 2.0$  V,  $V_{CC} = 3.0$  V.

2. Sample Rate=32 KHz.

- 3. Bias Current=26uA.
- 4. Volume Level=0x1F.

**Frequency Response Diagram of Headphone Driver**

Actions Semiconductor

PA Frequency Response (linein->PA)@1Vpp

02/09/04 14:24:58

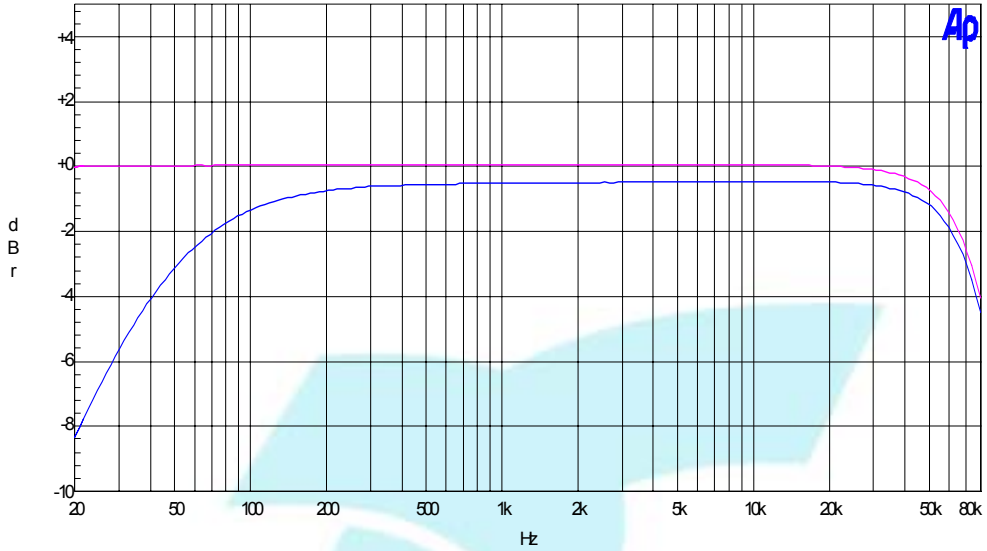

Sweep	Trace	Color	LineStyle	Thick	Data	Axis	Comment
1	1	Magenta	Solid	1	Anlr/Ampl	Left	Load=100uF*100Kohm
2	1	Blue	Solid	1	Anlr/Ampl	Left	Load=100uF*32ohm

Untitled1

**THD + N Amplitude Diagram of Headphone Driver**

Actions Semiconductor

PA THD+N vs Amplitude (linein->PA)@1K-hz Load=32ohm

02/09/04 10:19:46

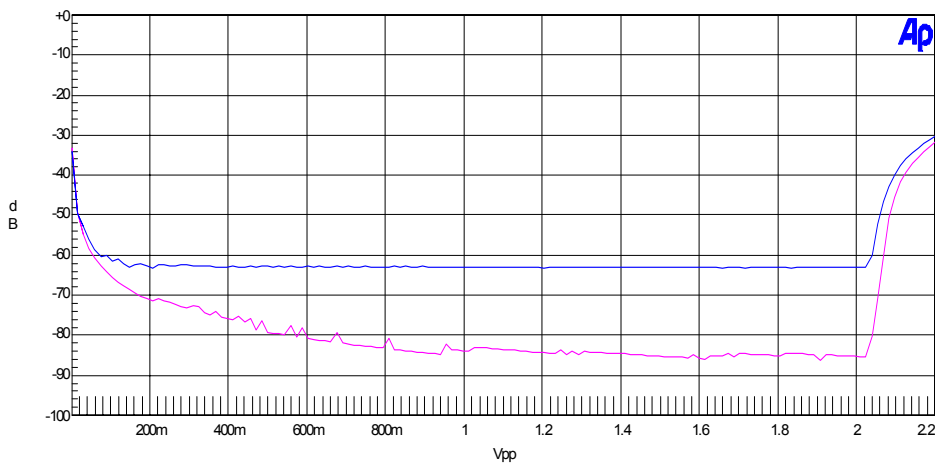

Sweep	Trace	Color	LineStyle	Thick	Data	Axis	Comment
1	1	Magenta	Solid	1	Anlr:THD+N Ratio	Left	Right Channel
2	1	Blue	Solid	1	Anlr:THD+N Ratio	Left	Left Channel

Untitled1

5.4.11 LCM Driver Parameter

LCM Interface Timing

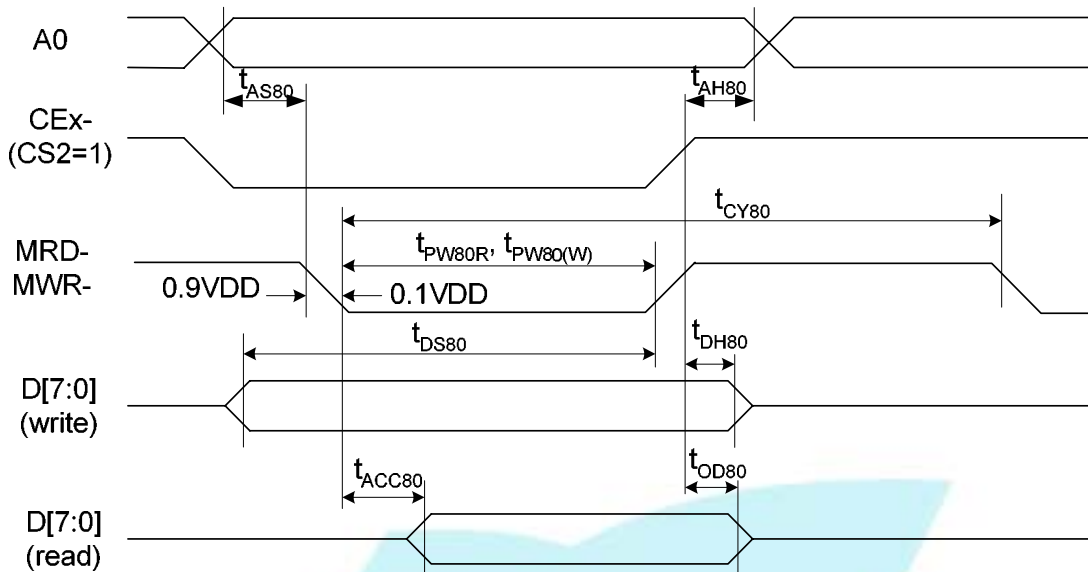

Parameter	Symbol	Condition	Typ	Unit
Data access time(write)	$t_{PW80(W)}$	HOSC=24.576mHZ	29	ns
Data access time (Read)	$t_{PW80(R)}$	HOSC=24.576mHZ	67	ns
Write cycle time	$t_{CY80(W)}$	HOSC=24.576mHZ	407	ns
Read cycle time	$t_{CY80(R)}$	HOSC=24.576mHZ	284	ns
Data setup time	$t_{DS80}$	HOSC=24.576mHZ	79	ns
Data hold time	$t_{DH80}$	HOSC=24.576mHZ	8	ns
Address setup time	$t_{AS80}$	HOSC=24.576mHZ	11	ns
Address hold time	$t_{AH80}$	HOSC=24.576mHZ	11	ns
Read access time	$t_{ACC80}$	HOSC=24.576mHZ	13	ns
Data input hold time	$t_{OD80}$	HOSC=24.576mHZ	8	ns

## 6. MCU/DSP Dissipation (IVDD VS. Frequency)

### 6.1 MCU Dissipation

(VBAT=1.5V, DSP under reset, VDD=2.0V, MCU runs in internal SRAM)

Clock Source	Divisor factor	IVDD(Max)
32.768KHZ	/(1—1024)	350uA
24.576MHz	/1	5.9mA
	/2	3.3mA
	/4	1.9mA
	/8	1.2mA
	/16	1.9mA
	/32	0.7mA
	/64	0.6mA
	/128	0.58mA
	/256	0.56mA
	/512	0.55mA
	/1024	0.54mA

### 6.2 DSP Dissipation (VBAT=1.5V, MCU run LOSC, VDD=2.0V, Vcc =3.0V)

DSP Speed (MIPS)	IVDD (Max)
6	3.49mA @ VDD=2.0V
12	6.52mA @ VDD=2.0V
24	11.24mA @ VDD=2.0V
36	16.24mA @ VDD=2.0V
48	21.08mA @ VDD=2.0V
60	28.5mA @ VDD=2.3V
72	33.6mA @ VDD=2.3V
84	38.7mA @ VDD=2.3V

## 7. Recommended Soldering Conditions

### 7.1 Soldering Conditions

Soldering Conditions for Surface-Mount Devices

Soldering Process	Soldering Conditions
Infrared ray reflow	Peak package's surface temperature: 235
	Reflow time: 30 seconds or less (210 or more)
	Maximum allowable number of reflow processes: 2
	Exposure limit: 3 days (10 hours of pre-baking is required at 125 afterward).
Partial heating method	Terminal temperature: 300 or less
	Heat time: 3 seconds or less (for one side of a device)

Note: Maximum number of days during which the product can be stored at the temperature of 25 and relative humidity of 65% or less after dry-pack package is opened.

Caution: Do not apply two or more different soldering methods to one chip (except for partial heating method for terminal sections).

### 7.2 Precaution against ESD for Semiconductors

Strong electric field, when exposed to a MOS device, can cause destruction of the gate oxide and ultimately degrade the device operation. Steps must be taken to stop generation of static electricity as much as possible, and quickly dissipate it once, when it has occurred. Environmental control must be adequate. When it is dry, humidifier should be used. It is recommended to avoid using insulators that easily build static electricity. Semiconductor devices must be stored and transported in an anti-static container, static shielding bag or conductive material. All test and measurement tools including work bench and floor should be grounded. The operator should be grounded using wrist strap. Semiconductor devices must not be touched with bare hands. Similar precautions need to be taken for PW boards with semiconductor devices on it.

### 7.3 Handling of Unused Input Pins for CMOS

No connection for CMOS device inputs can be cause of malfunction. If no connection is provided to



the input pins, it is possible that an internal input level may be generated due to noise, etc., hence causing malfunction. CMOS devices behave differently than Bipolar or NMOS devices. Input levels of CMOS devices must be fixed high or low by using a pull-up or pull-down circuitry. Each unused pin should be connected to VDD or GND with a resistor, if it is considered to have a possibility of being an output pin. All handling related to the unused pins must be judged device by device and related specifications governing the devices.

#### 7.4 Status before Initialization of MOS Devices

Power-on does not necessarily define initial status of MOS device. Production process of MOS does not define the initial operation status of the device. Immediately after the power source is turned ON, the devices with reset function have not yet been initialized. Hence, power-on does not guarantee out-pin levels, I/O settings or contents of registers. Device is not initialized until the reset signal is received. Reset operation must be executed immediately after power-on for devices having reset function.

### 8. Package Drawings

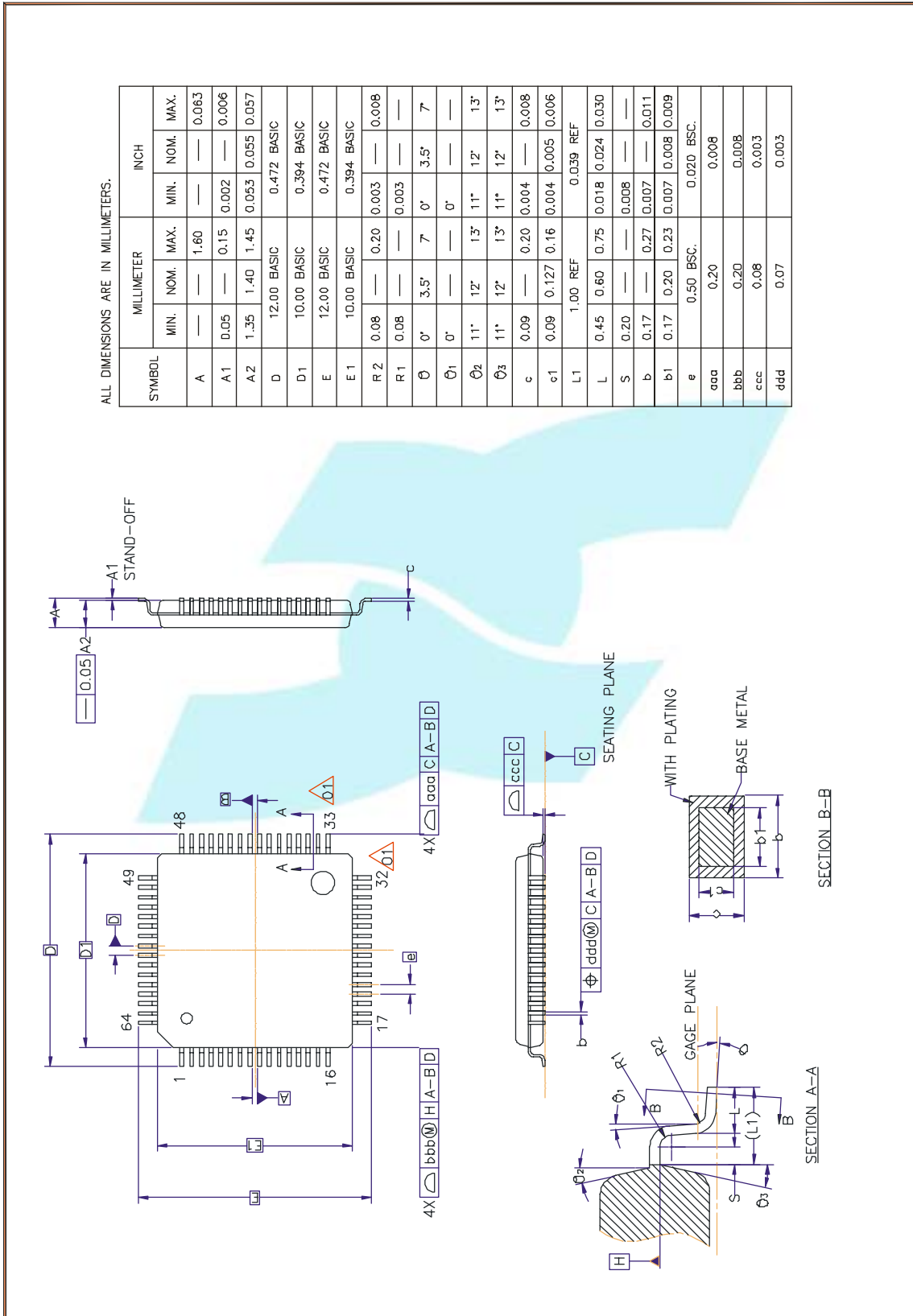

**Actions Semiconductor Co., Ltd.**

**Address: 15-1, NO.1, HIT Road, Tangjia, Zhuhai, Guangdong, China**

**Tel: +86-756-3392353**

**Fax: +86-756-3392251, 3392252, 3392253**

**Post code: 519085**

**[http:// www.actions.com.cn](http://www.actions.com.cn)**

**Business Email: [mp-sales@actions.com.cn](mailto:mp-sales@actions.com.cn)**

**Technical Service Email: [mp-cs@actions.com.cn](mailto:mp-cs@actions.com.cn)**