

PLEASE CHECK WWW.MOLEX.COM FOR LATEST PART INFORMATION

Part Number: **0501258100**
Status: **Active**
Overview: picoblade
Description: 1.25mm (.049") Pitch PicoBlade™ Crimp Terminal 50125, 26-28 AWG, Bag

Documents:

[Drawing \(PDF\)](#) [RoHS Certificate of Compliance \(PDF\)](#)
[Product Specification PS-51021-009 \(PDF\)](#)

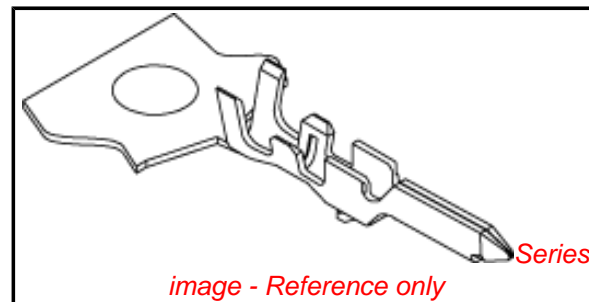

General

Product Family	Crimp Terminals
Series	<u>50125</u>
Crimp Quality Equipment	Yes
Overview	<u>picoblade</u>
Product Name	PicoBlade™

Physical

Gender	Male
Material - Metal	Phosphor Bronze
Material - Plating Mating	Tin
Material - Plating Termination	Tin
Packaging Type	Bag
Plating min: Mating (µin)	36
Plating min: Mating (µm)	0.90
Plating min: Termination (µin)	36
Plating min: Termination (µm)	0.90
Termination Interface: Style	Crimp or Compression
Wire Insulation Diameter	0.50-1.00mm (.020-.039")
Wire Size AWG	26, 28
Wire Size mm²	N/A

Electrical

Current - Maximum per Contact	1A
Voltage - Maximum	125V

Material Info

Reference - Drawing Numbers

Packaging Specification	SPK-50125-001
Product Specification	PS-51021-009, RPS-50125-001, RPS-51021-033
Sales Drawing	SD-50125-8*00

EU RoHS

**ELV and RoHS
Compliant**
**REACH SVHC
Contains SVHC: No**
**Halogen-Free
Status**
Halogen-Free

China RoHS



**Need more information on product
environmental compliance?**

Email productcompliance@molex.com
For a multiple part number RoHS Certificate of Compliance, [click here](#)

Please visit the [Contact Us](#) section for any non-product compliance questions.

Search Parts in this Series

50125Series

Mates With

50058 Crimp Terminal, 50079 Crimp Terminal

Use With

51047 Crimp Housing

Application Tooling | FAQ

Tooling specifications and manuals are found by selecting the products below. Crimp Height Specifications are then contained in the Application Tooling Specification document.

Global

Description	Product #
Hand Crimp Tool for 1.25mm (.049") Pitch PicoBlade™ Crimp Terminals, 26-32 AWG	<u>0638190400</u>

Extraction Tool	<u>0011030043</u>
-----------------	-------------------

Japan

Description	Product #
-------------	-----------

Extraction Tool	<u>0570726000</u>
Hand Crimper	<u>0571405000</u>

This document was generated on 05/19/2010

PLEASE CHECK WWW.MOLEX.COM FOR LATEST PART INFORMATION

DWG. NO. SD-50125-8*00

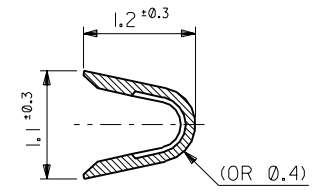
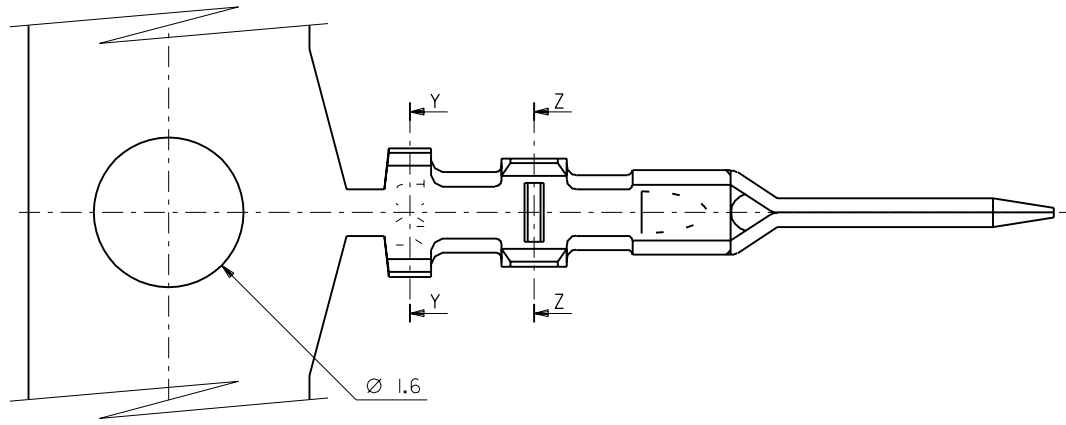

SECT. Z-Z

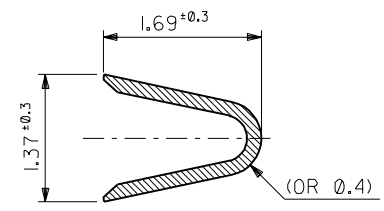

SECT. Y-Y

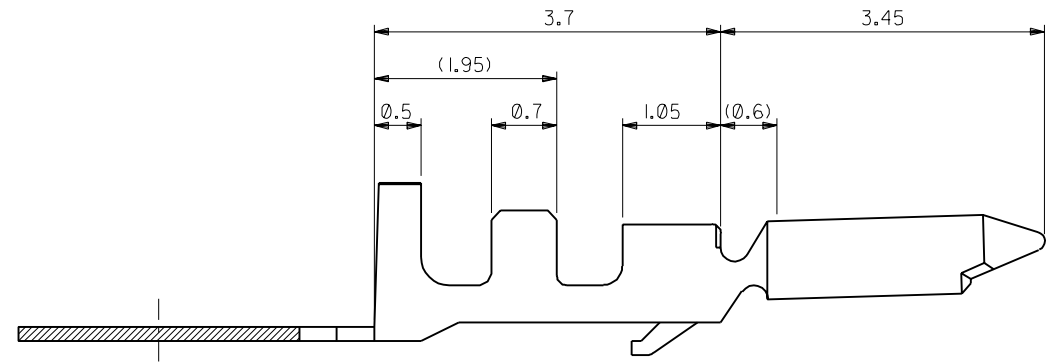
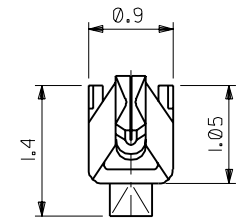

50125-8100	バラ状 LOOSE
50125-8000	連鎖状 CHAIN
ENG. NO.	端子形状 FORM

注記
NOTES

- 適合ハウジング: 51047シリーズ
APPLICABLE HOUSING: 51047 SERIES
- メッキ仕様 PLATING
錫 0.9μm MIN. リフロー処理 (前メッキ)
TIN 0.9μm MIN. REFLOW TREATMENT (PRE-PLATED)

角度 ANGLE	±3°				
30以上 OVER	+0.3				
10以上 30未満 UNDER	+0.25	D	変更 REVISED	(J30883)	H.H. M.F.
10未満 UNDER	+0.2	C	変更&再作図 REVISED & REDRAWN	(J20810)	H.H. M.F.
一般公差 GENERAL TOLERANCES		記号 LTR	変更内容 REVISION RECORD	DR. CHK.	日付 DATE

材料 MATERIAL	リン青銅 PHOSPHOR BRONZE
仕上げ FINISH	—H—
適用電線範囲 WIRE RANGE	AWG #26-28
被覆外径 INS. RANGE	φ 0.5-1.0
DRAWN BY	'92/10/27 H.HIRAMOTO
CHK'D BY	'93/9/6 M.FUKUSHIMA
APP'D BY	'93/9/6 M.FUKUSHIMA
尺度	20 - 1

MOLEX-JAPAN CO.,LTD. 日本モレックス株式会社	
REVISE ONLY ON CAD SYSTEM	
TITLE 名称	
I.25 WIRE TO WIRE CONN. CRIMP PLUG TERMINAL	
DWG. NO.	REV
SD-50125-8*00	D