

# Clock Generator for Intel<sup>®</sup> Calistoga Chipset

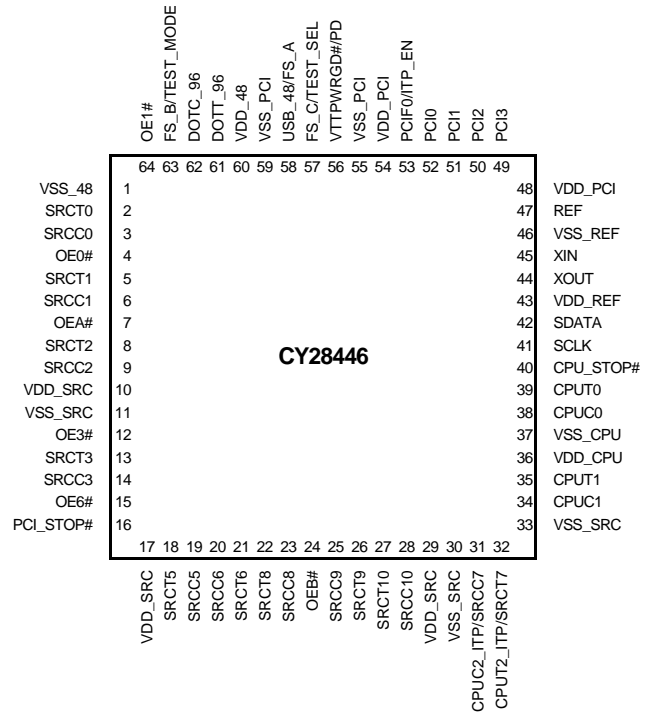
## Features

- Compliant to Intel<sup>®</sup> CK410M
- Selectable CPU frequencies
- Low power differential CPU clock pairs
- 100-MHz low power differential SRC clocks
- 96-MHz low power differential DOT clock
- 48-MHz USB clock
- SRC clocks stoppable through OE#
- 33-MHz PCI clocks
- Buffered 14.318-MHz reference clock
- Low-voltage frequency select input
- I<sup>2</sup>C support with readback capabilities
- Ideal Lexmark Spread Spectrum profile for maximum electromagnetic interference (EMI) reduction
- 3.3V power supply
- 64-pin QFN package

Table 1. Output Configuration table

CPU	SRC	PCI	REF	DOT96	48M
x2 / x3	x9/10	x5	x1	x 1	x 1

## Pin Configuration



**Table 2. Frequency Table**

FS_C	FS_B	FS_A	CPU	SRC/SATA	PCIF/PCI	REF	LCD	DOT96	USB
MID	0	1	100	100	33	14.318	100	96	48
0	0	1	133	100	33	14.318	100	96	48
0	1	1	166	100	33	14.318	100	96	48
0	1	0	200	100	33	14.318	100	96	48
0	0	0							
MID	0	0							
MID	1	0							
MID	1	1	Reserved	100	33	14.318	100	96	"
1	0	x	Hi-Z	Hi-Z	Hi-Z	Hi-Z	Hi-Z	Hi-Z	Hi-Z
1	1	0	REF/2	REF/8	REF/24	REF	REF/8	REF	REF
1	1	1	REF/2	REF/8	REF/24	REF	REF/8	REF	REF

**Pin Description**

Pin No.	Name	Type	Description
1	VSS_48	GND	<b>Ground for outputs.</b>
2, 3, 5, 6, 8, 9, 13, 14, 18, 19, 20, 21, 22, 23, 25, 26, 27, 28	SRC(0:3, 5:6, 8:10) [T/C]	O, DIF	<b>100-MHz Differential serial reference clocks</b>
4, 7, 12, 15, 24, 64	OE[0, 1, 3, 6, A, B]#	I, PU	<b>3.3V LVTTTL input for enabling assigned SRC clock (active LOW)</b>
10, 17, 29,	VDD_SRC	PWR	<b>3.3V power supply for outputs.</b>
11, 30, 33	VSS_SRC	GND	<b>Ground for outputs.</b>
16	PCI_STP#	I, PU	<b>3.3V LVTTTL input for PCI_STP#</b> Stops SRC and PCI clocks not set to free running in the SMBUS registers.
31, 32	CPU2_ITPT/SRCT7, CPU2_ITPC/ SRCC7	O, DIF	<b>Selectable differential CPU clock/100-MHz Differential serial reference clock.</b> Selectable via Pin 53 PCIF0/ITP_EN
34, 35, 38, 39	CPUT/C[0:1]	O, DIF	<b>Differential CPU clock outputs.</b>
36	VDD_CPU	PWR	<b>3.3V power supply for outputs.</b>
37	VSS_CPU	GND	<b>Ground for outputs.</b>
40	CPU_STP#	I, PU	<b>3.3V LVTTTL input for CPU_STP# active LOW.</b>
41	SCLK	I	<b>SMBus-compatible SCLOCK.</b>
42	SDATA	I/O, OD	<b>SMBus-compatible SDATA.</b>
43	VDD_REF	PWR	<b>3.3V power supply for outputs.</b>
44	XOUT	O, SE	<b>14.318-MHz crystal output.</b>
45	XIN	I	<b>14.318-MHz crystal input.</b>
46	VSS_REF	GND	<b>Ground for outputs.</b>
47	REF	O,SE	<b>Fixed 14.318-MHz clock output.</b>
48, 54	VDD_PCI	PWR	<b>3.3V power supply for outputs.</b>
49, 50, 51, 52	PCI[0:3]	O, SE	<b>33-MHz clock output</b>
53	PCIF0/ITP_EN	I/O, PD	<b>33-MHz clock output (not stoppable by PCI_STOP#) / 3.3V LVTTTL input for selecting pins 31/32 (CPU2_ITP[T/C]/SRC7[T/C])</b> (sampled on the VTT_PWRGD# assertion). 0 (default): SRC7[T/C] 1: CPU2_ITP[T/C]
55, 59	VSS_PCI	GND	<b>Ground for outputs.</b>
56	VTT_PWRGD#/PD	I, PD	<b>3.3V LVTTTL input.</b> This pin is a level sensitive strobe used to latch the FS_A, FS_B, FS_C, and all I/O configuration pins,. After VTT_PWRGD# (active LOW) assertion, this pin becomes a real-time input for asserting power-down (active HIGH).
57	FS_C/TEST_SEL	I, PD	<b>3.3V-tolerant input for CPU frequency selection/Selects test mode if pulled to V<sub>IMFS_C</sub> when VTT_PWRGD# is asserted LOW.</b> <i>Refer to DC Electrical Specifications table for V<sub>ILFS_C</sub>, V<sub>IMFS_C</sub>, V<sub>IHFS_C</sub> specifications.</i>
58	USB_48/FS_A	I/O, PU	<b>Fixed 48-MHz clock output / 3.3V-tolerant input for CPU frequency selection.</b> <i>Refer to DC Electrical Specifications table for V<sub>il_FS</sub> and V<sub>Ih_FS</sub> specifications.</i>
60	VDD_48	PWR	<b>3.3V power supply for outputs.</b>
61,62	DOT_96[T/C]	O, DIF	<b>Fixed 96-MHz clock output.</b>
63	FS_B/TEST_MODE	I, PU	<b>3.3V-tolerant input for CPU frequency selection Selects Ref/N or Tri-state when in test mode</b> 0 = Tri-state, 1 = Ref/N <i>Refer to DC Electrical Specifications table for V<sub>il_FS</sub> and V<sub>Ih_FS</sub> specifications.</i>

### Frequency Select Pins (FS\_A, FS\_B, and FS\_C)

Host clock frequency selection is achieved by applying the appropriate logic levels to FS\_A, FS\_B, FS\_C inputs prior to VTT\_PWRGD# assertion (as seen by the clock synthesizer). Upon VTT\_PWRGD# being sampled LOW by the clock chip (indicating processor VTT voltage is stable), the clock chip samples the FS\_A, FS\_B, and FS\_C input values. For all logic levels of FS\_A, FS\_B, and FS\_C, VTT\_PWRGD# employs a one-shot functionality in that once a valid LOW on VTT\_PWRGD# has been sampled, all further VTT\_PWRGD#, FS\_A, FS\_B, and FS\_C transitions will be ignored, except in test mode.

### Serial Data Interface

To enhance the flexibility and function of the clock synthesizer, a two-signal serial interface is provided. Through the Serial Data Interface, various device functions, such as individual clock output buffers, can be individually enabled or disabled. The registers associated with the Serial Data Interface

initialize to their default setting upon power-up, and therefore use of this interface is optional. Clock device register changes are normally made upon system initialization, if any are required. The interface cannot be used during system operation for power management functions.

### Data Protocol

The clock driver serial protocol accepts byte write, byte read, block write, and block read operations from the controller. For block write/read operation, the bytes must be accessed in sequential order from lowest to highest byte (most significant bit first) with the ability to stop after any complete byte has been transferred. For byte write and byte read operations, the system controller can access individually indexed bytes. The offset of the indexed byte is encoded in the command code, as described in *Table 3*.

The block write and block read protocol is outlined in *Table 4* while *Table 5* outlines the corresponding byte write and byte read protocol. The slave receiver address is 11010010 (D2h).

**Table 3. Command Code Definition**

Bit	Description
7	0 = Block read or block write operation, 1 = Byte read or byte write operation
(6:0)	Byte offset for byte read or byte write operation. For block read or block write operations, these bits should be '0000000'

**Table 4. Block Read and Block Write Protocol**

Block Write Protocol		Block Read Protocol	
Bit	Description	Bit	Description
1	Start	1	Start
8:2	Slave address – 7 bits	8:2	Slave address – 7 bits
9	Write	9	Write
10	Acknowledge from slave	10	Acknowledge from slave
18:11	Command Code – 8 bits	18:11	Command Code – 8 bits
19	Acknowledge from slave	19	Acknowledge from slave
27:20	Byte Count – 8 bits (Skip this step if I <sup>2</sup> C_EN bit set)	20	Repeat start
28	Acknowledge from slave	27:21	Slave address – 7 bits
36:29	Data byte 1 – 8 bits	28	Read = 1
37	Acknowledge from slave	29	Acknowledge from slave
45:38	Data byte 2 – 8 bits	37:30	Byte Count from slave – 8 bits
46	Acknowledge from slave	38	Acknowledge
....	Data Byte /Slave Acknowledges	46:39	Data byte 1 from slave – 8 bits
....	Data Byte N – 8 bits	47	Acknowledge
....	Acknowledge from slave	55:48	Data byte 2 from slave – 8 bits
....	Stop	56	Acknowledge
		....	Data bytes from slave / Acknowledge
		....	Data Byte N from slave – 8 bits
		....	NOT Acknowledge
		....	Stop

**Table 5. Byte Read and Byte Write Protocol**

Byte Write Protocol		Byte Read Protocol	
Bit	Description	Bit	Description
1	Start	1	Start
8:2	Slave address – 7 bits	8:2	Slave address – 7 bits
9	Write	9	Write
10	Acknowledge from slave	10	Acknowledge from slave
18:11	Command Code – 8 bits	18:11	Command Code – 8 bits
19	Acknowledge from slave	19	Acknowledge from slave
27:20	Data byte – 8 bits	20	Repeated start
28	Acknowledge from slave	27:21	Slave address – 7 bits
29	Stop	28	Read
		29	Acknowledge from slave
		37:30	Data from slave – 8 bits
		38	NOT Acknowledge
		39	Stop

## Control Registers

### Byte 0: Control Register 0

Bit	@Pup	Name	Description
7	1	CPU2_ITP[T/C]/SRC7[T/C]	CPU2_ITP[T/C]/SRC[T/C]7 Output Enable 0 = Disable (Tri-state), 1 = Enable
6	1	SRC[T/C]6	SRC[T/C]6 Output Enable 0 = Disable (Tri-state), 1 = Enable
5	1	SRC[T/C]5	SRC[T/C]5 Output Enable 0 = Disable (Tri-state), 1 = Enable
4	1	Reserved	Reserved
3	1	SRC[T/C]3	SRC[T/C]3 Output Enable 0 = Disable (Tri-state), 1 = Enable
2	1	SRC[T/C]2	SRC[T/C]2 Output Enable 0 = Disable (Tri-state), 1 = Enable
1	1	SRC[T/C]1	SRC[T/C]1 Output Enable 0 = Disable (Tri-state), 1 = Enable
0	1	SRC[T/C]0	SRC[T/C]0 Output Enable 0 = Disable (Tri-state), 1 = Enable

### Byte 1: Control Register 1

Bit	@Pup	Name	Description
7	1	PCIF0	PCIF0 Output Enable 0 = Disable, 1 = Enable
6	1	DOT_96[T/C]	DOT_96 MHz Output Enable 0 = Disable (Tri-state), 1 = Enable
5	1	USB_48	USB_48 Output Enable 0 = Disable, 1 = Enable
4	1	REF	REF Output Enable 0 = Disable, 1 = Enable
3	1	Reserved	Reserved
2	1	CPU[T/C]1	CPU[T/C]1 Output Enable 0 = Disable (Tri-state), 1 = Enable
1	1	CPU[T/C]0	CPU[T/C]0 Output Enable 0 = Disable (Tri-state), 1 = Enable
0	0	CPU PLL Spread Enable	PLL1 (CPU PLL) Spread Spectrum Enable 0 = Spread off 1 = Spread on (-0.5% spread spectrum on CPU/SRC/PCI clocks)

### Byte 2: Control Register 2

Bit	@Pup	Name	Description
7	1	Reserved	Reserved set to 1
6	1	Reserved	Reserved set to 1
5	1	PCI3	PCI3 Output Enable 0 = Disable, 1 = Enable
4	1	PCI2	PCI2 Output Enable 0 = Disable, 1 = Enable
3	1	PCI1	PCI1 Output Enable 0 = Disable, 1 = Enable
2	1	PCI0	PCI0 Output Enable 0 = Disable, 1 = Enable
1	1	Reserved	Reserved set to 1
0	1	Reserved	Reserved set to 1

**Byte 3: Control Register 3**

Bit	@Pup	Name	Description
7	0	SRC7	Allow control of SRC[T/C]7 with assertion of OEB# 0 = Free running, 1 = Stopped with OEB#
6	0	Reserved	Reserved set to 0
5	0	SRC5	Allow control of SRC[T/C]5 with assertion of OEB# 0 = Free running, 1 = Stopped with OEB#
4	0	Reserved	Reserved set to 0
3	0	Reserved	Reserved set to 0
2	0	SRC2	Allow control of SRC[T/C]2 with assertion of OEB# 0 = Free running, 1 = Stopped with OEB#
1	0	Reserved	Reserved set to 0
0	0	Reserved	Reserved set to 0

**Byte 4: Control Register 4**

Bit	@Pup	Name	Description
7	1	Reserved	Reserved set to 1
6	0	DOT96[T/C]	DOT PWRDWN Drive Mode 0 = Driven in PWRDWN, 1 = Tri-state
5	0	Reserved	Reserved set to 0
4	1	Reserved	Reserved set to 1
3	0	PCIF0	Allow control of PCIF0 with assertion of SW and HW PCI_STP# 0 = Free running, 1 = Stopped with PCI_STP#
2	1	CPU[T/C]2	Allow control of CPU[T/C]2 with assertion of CPU_STP# 0 = Free running, 1 = Stopped with CPU_STP#
1	1	CPU[T/C]1	Allow control of CPU[T/C]1 with assertion of CPU_STP# 0 = Free running, 1 = Stopped with CPU_STP#
0	1	CPU[T/C]0	Allow control of CPU[T/C]0 with assertion of CPU_STP# 0 = Free running, 1 = Stopped with CPU_STP#

**Byte 5: Control Register 5**

Bit	@Pup	Name	Description
7	0	Reserved	Reserved set to 0
6	0	CPU[T/C]2	CPU[T/C]2 Stop Drive Mode 0 = Driven when CPU_STP# asserted, 1 = Tri-state when CPU_STP# asserted
5	0	CPU[T/C]1	CPU[T/C]1 Stop Drive Mode 0 = Driven when CPU_STP# asserted, 1 = Tri-state when CPU_STP# asserted
4	0	CPU[T/C]0	CPU[T/C]0 Stop Drive Mode 0 = Driven when CPU_STP# asserted, 1 = Tri-state when CPU_STP# asserted
3	0	SRC[T/C]	SRC[T/C] PWRDWN Drive Mode 0 = Driven when PD asserted, 1 = Tri-state when PD asserted
2	0	CPU[T/C]2	CPU[T/C]2 PWRDWN Drive Mode 0 = Driven when PD asserted, 1 = Tri-state when PD asserted
1	0	CPU[T/C]1	CPU[T/C]1 PWRDWN Drive Mode 0 = Driven when PD asserted, 1 = Tri-state when PD asserted
0	0	CPU[T/C]0	CPU[T/C]0 PWRDWN Drive Mode 0 = Driven when PD asserted, 1 = Tri-state when PD asserted

**Byte 6: Control Register 6**

Bit	@Pup	Name	Description
7	0	REF/N or Tri-state Select	REF/N or Tri-state Select 1 = REF/N, 0 = Tri-state
6	0	Test Mode	Test Mode Control 1 = Ref/N or Tristate, 0 = Normal Operation
5	1	Reserved	Reserved set to 1
4	0	REF	REF Output Drive Strength 0 = Low, 1 = High
3	1	PCI and PCIF clock outputs except those set to free running	SW PCI_STP Function 0 = SW PCI_STP assert, 1 = SW PCI_STP deassert When this bit is set to 0, all STOPPABLE PCI and PCIF outputs will be stopped in a synchronous manner with no short pulses. When this bit is set to 1, all STOPPED PCI and PCIF outputs will resume in a synchronous manner with no short pulses.
2	HW	FS_C	FSC Reflects the value of the FS_C pin sampled on power-up 0 = FSC was low during VTT_PWRGD# assertion
1	HW	FS_B	FSB Reflects the value of the FS_B pin sampled on power-up 0 = FSB was low during VTT_PWRGD# assertion
0	HW	FS_A	FSA Reflects the value of the FS_A pin sampled on power-up 0 = FSA was low during VTT_PWRGD# assertion

**Byte 7: Vendor ID**

Bit	@Pup	Name	Description
7	0	Revision Code Bit 3	Revision Code Bit 3
6	0	Revision Code Bit 2	Revision Code Bit 2
5	1	Revision Code Bit 1	Revision Code Bit 1
4	1	Revision Code Bit 0	Revision Code Bit 0
3	1	Vendor ID Bit 3	Vendor ID Bit 3
2	0	Vendor ID Bit 2	Vendor ID Bit 2
1	0	Vendor ID Bit 1	Vendor ID Bit 1
0	0	Vendor ID Bit 0	Vendor ID Bit 0

**Byte 8: Control Register 7**

Bit	@Pup	Name	Description
7	0	Reserved	Reserved set to 0
6	1	SRC[T/C]10	SRC[T/C]10 Output Enable 0 = Disable (Tri-state), 1 = Enable
5	1	SRC[T/C]9	SRC[T/C]9 Output Enable 0 = Disable (Tri-state), 1 = Enable
4	1	SRC[T/C]8	SRC[T/C]8 Output Enable 0 = Disable (Tri-state), 1 = Enable
3	0	Reserved	Reserved set to 0
2	0	SRC10	Allow control of SRC[T/C]10 with assertion of OEA# 0 = Free running, 1 = Stopped with OEA#
1	0	SRC9	Allow control of SRC[T/C]9 with assertion of OEB# 0 = Free running, 1 = Stopped with OEB#
0	0	SRC8	Allow control of SRC[T/C]8 with assertion of OEA# 0 = Free running, 1 = Stopped with OEA#



Byte 9: Control Register 8

Bit	@Pup	Name	Description
7	0	PCI3	33-MHz Output drive strength 0 = Low, 1 = High
6	0	PCI2	33-MHz Output drive strength 0 = Low, 1 = High
5	0	PCI1	33-MHz Output drive strength 0 = Low, 1 = High
4	0	PCI0	33-MHz Output drive strength 0 = Low, 1 = High
3	0	PCIF0	33-MHz Output drive strength 0 = Low, 1 = High
2	1	Reserved	Reserved set to 1
1	1	Reserved	Reserved set to 1
0	1	Reserved	Reserved set to 1

Crystal Recommendations

Frequency (Fund)	Cut	Loading	Load Cap	Drive (max.)	Shunt Cap (max.)	Motional (max.)	Tolerance (max.)	Stability (max.)	Aging (max.)
14.31818 MHz	AT	Parallel	20 pF	0.1 mW	5 pF	0.016 pF	35 ppm	30 ppm	5 ppm

The CY28446 requires a Parallel Resonance Crystal. Substituting a series resonance crystal will cause the CY28446 to operate at the wrong frequency and violate the ppm specification. For most applications there is a 300-ppm frequency shift between series and parallel crystals due to incorrect loading

correctly calculate crystal loading. As mentioned previously, the capacitance on each side of the crystal is in series with the crystal. This means the total capacitance on each side of the crystal must be twice the specified crystal load capacitance (CL). While the capacitance on each side of the crystal is in series with the crystal, trim capacitors (Ce1,Ce2) should be calculated to provide equal capacitive loading on both sides.

Crystal Loading

Crystal loading plays a critical role in achieving low ppm performance. To realize low ppm performance, the total capacitance the crystal will see must be considered to calculate the appropriate capacitive loading (CL).

Figure 1 shows a typical crystal configuration using the two trim capacitors. An important clarification for the following discussion is that the trim capacitors are in series with the crystal not parallel. It's a common misconception that load capacitors are in parallel with the crystal and should be approximately equal to the load capacitance of the crystal. This is not true.

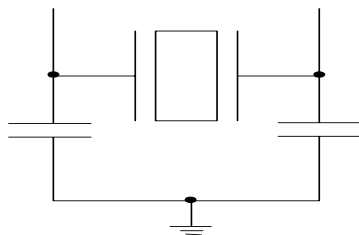


Figure 1. Crystal Capacitive Clarification

Calculating Load Capacitors

In addition to the standard external trim capacitors, trace capacitance and pin capacitance must also be considered to

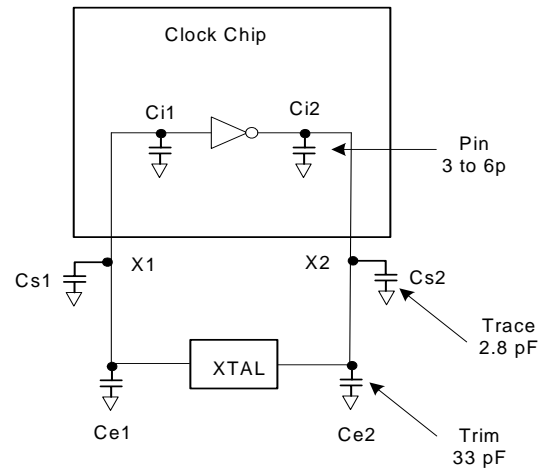


Figure 2. Crystal Loading Example

As mentioned previously, the capacitance on each side of the crystal is in series with the crystal. This means the total capacitance on each side of the crystal must be twice the specified load capacitance (CL). While the capacitance on each side of the crystal is in series with the crystal, trim capacitors (Ce1,Ce2) should be calculated to provide equal capacitance loading on both sides.

Use the following formulas to calculate the trim capacitor values for Ce1 and Ce2.

**Load Capacitance (each side)**

$$C_e = 2 * C_L - (C_s + C_i)$$

**Total Capacitance (as seen by the crystal)**

$$C_{Le} = \frac{1}{\left( \frac{1}{C_{e1} + C_{s1} + C_{i1}} + \frac{1}{C_{e2} + C_{s2} + C_{i2}} \right)}$$

- CL ..... Crystal load capacitance
- CLe ..... Actual loading seen by crystal using standard value trim capacitors
- Ce ..... External trim capacitors
- Cs ..... Stray capacitance (terraced)
- Ci ..... Internal capacitance (lead frame, bond wires etc.)

**OE# Description**

The OE# signals are active LOW inputs used for clean enabling and disabling selected SRC outputs. The outputs controlled by OE[A,B]# are determined by the settings in register byte 3 and byte 8. OE[0,1,3,6]# controls SRC[0,1,3,6], respectively. The OE# signal is a debounced signal in that its state must remain unchanged during two consecutive rising edges of SRCC to be recognized as a valid assertion or deassertion. (The assertion and deassertion of this signal is absolutely asynchronous.)

**OE# Assertion (OE# -> LOW)**

All differential outputs that were stopped are to resume normal operation in a glitch-free manner. The maximum latency from the assertion to active outputs is between 2 and 6 SRC clock periods (2 clocks are shown) with all SRC outputs resuming simultaneously. All stopped SRC outputs must be driven HIGH within 10 ns of OE# deassertion to a voltage greater than 200 mV.

**OE# Deassertion (OE# -> HIGH)**

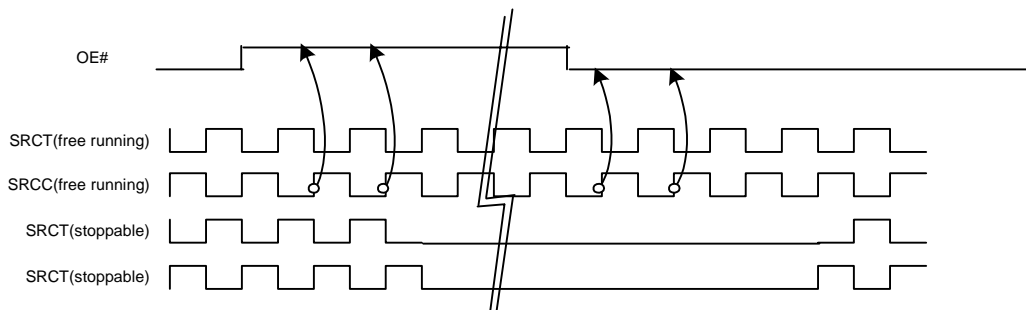
The impact of deasserting the OE# pins is that all SRC outputs that are set in the control registers to stoppable via deassertion of OE# are to be stopped after their next transition. The final state of all stopped SRC clocks is Low/Low.

**PD (Power-down) Clarification**

The VTT\_PWRGD# /PD pin is a dual-function pin. During initial power-up, the pin functions as VTT\_PWRGD#. Once VTT\_PWRGD# has been sampled LOW by the clock chip, the pin assumes PD functionality. The PD pin is an asynchronous active HIGH input used to shut off all clocks cleanly prior to shutting off power to the device. This signal is synchronized internal to the device prior to powering down the clock synthesizer. PD is also an asynchronous input for powering up the system. When PD is asserted HIGH, all clocks need to be driven to a low value and held prior to turning off the VCOs and the crystal oscillator.

**PD (Power-down) Assertion**

When PD is sampled HIGH by two consecutive rising edges of CPUC, all single-ended outputs will be held LOW on their next HIGH-to-LOW transition and differential clocks must held HIGH or tri-stated (depending on the state of the control register drive mode bit) on the next diff clock# HIGH-to-LOW transition within 4 clock periods. When the SMBus PD drive mode bit corresponding to the differential (CPU, SRC, and DOT) clock output of interest is programmed to '0', the clock output are held with "Diff clock" pin driven HIGH and "Diff clock#" driven LOW. If the control register PD drive mode bit corresponding to the output of interest is programmed to "1", then both the "Diff clock" and the "Diff clock#" are LOW. Note *Figure 4* shows CPUC = 133 MHz and PD drive mode = '1' for all differential outputs. This diagram and description is applicable to valid CPU frequencies 100, 133, 166, and 200 MHz. In the event that PD mode is desired as the initial power-on state, PD must be asserted HIGH in less than 10 μs after asserting Vtt\_PwrGd#. It should be noted that 96\_100\_SSC will follow the DOT waveform is selected for 96 MHz and the SRC waveform when in 100-MHz mode.



**Figure 3. OE# Deassertion/Assertion Waveform**

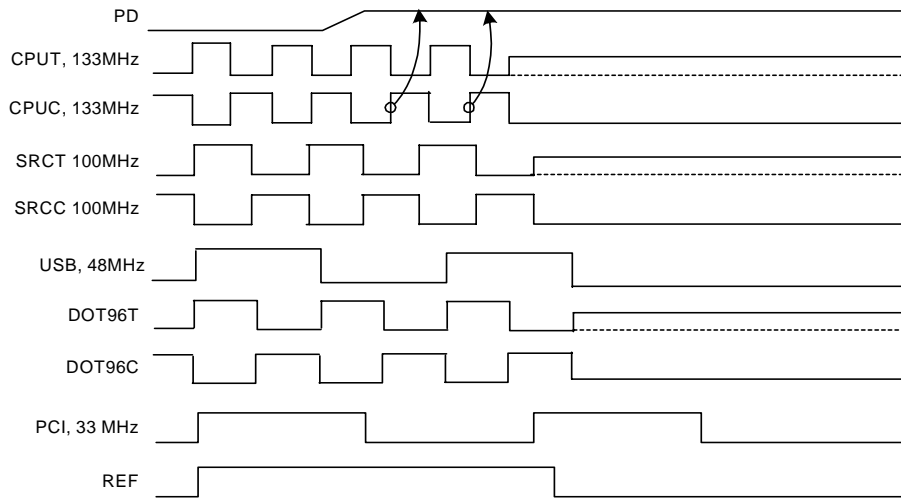


Figure 4. Power-down Assertion Timing Waveform

**PD Deassertion**

The power-up latency is less than 1.8 ms. This is the time from the deassertion of the PD pin or the ramping of the power supply until the time that stable clocks are output from the clock chip. All differential outputs stopped in a three-state condition resulting from power-down will be driven HIGH in less than 300  $\mu$ s of PD deassertion to a voltage greater than

200 mV. After the clock chip's internal PLL is powered up and locked, all outputs will be enabled within a few clock cycles of each other. *Figure 5* is an example showing the relationship of clocks coming up. It should be noted that 96\_100\_SSC will follow the DOT waveform when in 100-MHz mode.

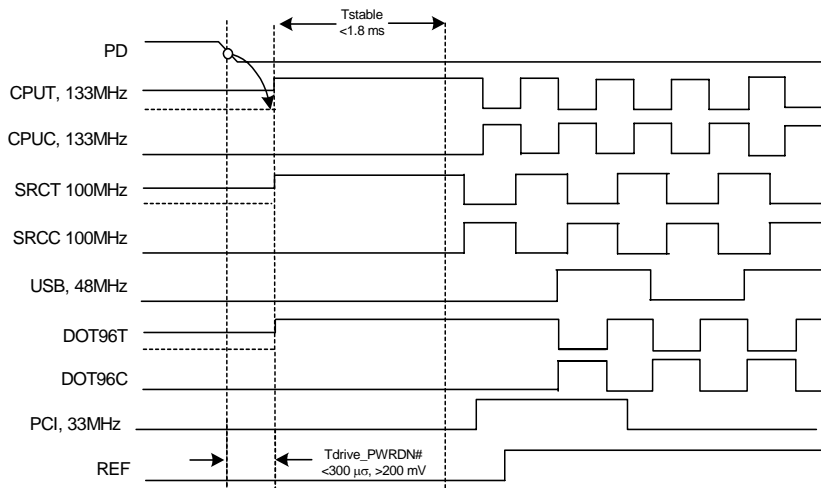


Figure 5. Power-down Deassertion Timing Waveform

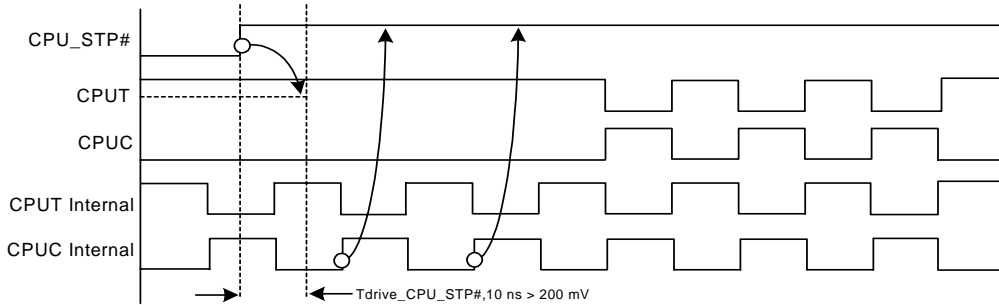
**CPU\_STP# Assertion**

The CPU\_STP# signal is an active LOW input used for synchronous stopping and starting the CPU output clocks while the rest of the clock generator continues to function. When the CPU\_STP# pin is asserted, all CPU outputs that are set with the SMBus configuration to be stoppable via assertion of CPU\_STP# will be stopped within two to six CPU clock periods after being sampled by two rising edges of the internal

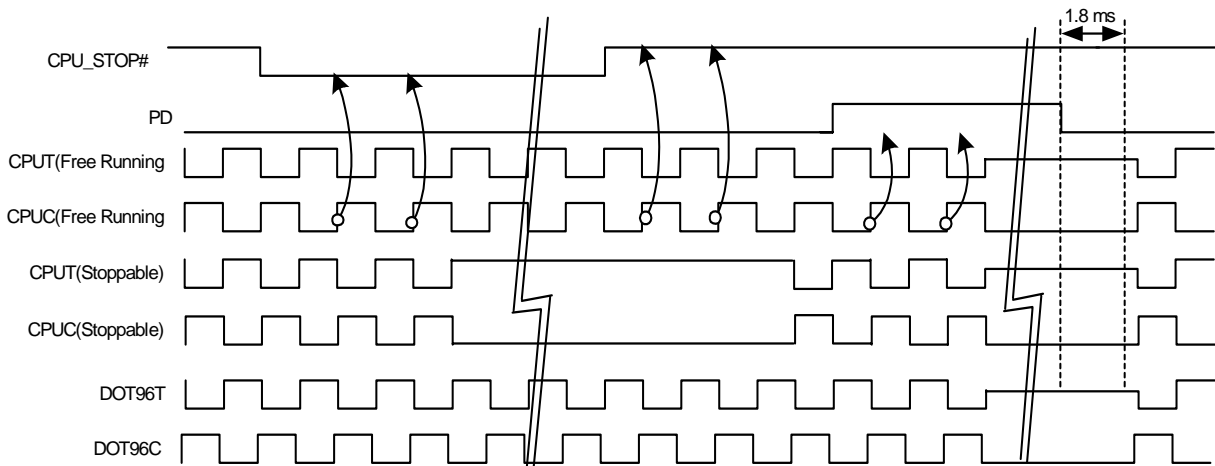
CPUC clock. The final state of all stopped CPU clocks is High/Low when driven, Low/Low when tri-stated

**CPU\_STP# Deassertion**

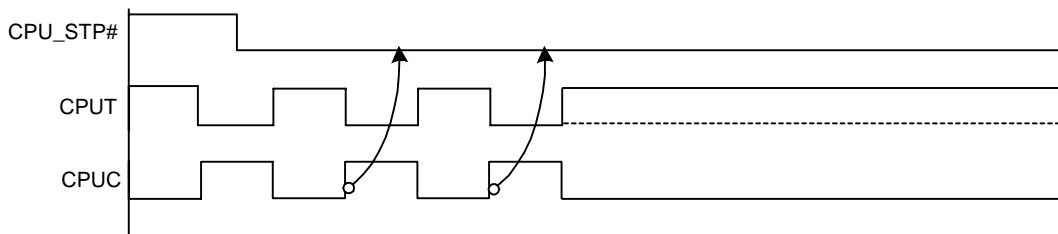
The deassertion of the CPU\_STP# signal will cause all CPU outputs that were stopped to resume normal operation in a synchronous manner, synchronous manner meaning that no short or stretched clock pulses will be produced when the clock resumes. The maximum latency from the deassertion to active outputs is no more than two CPU clock cycles.



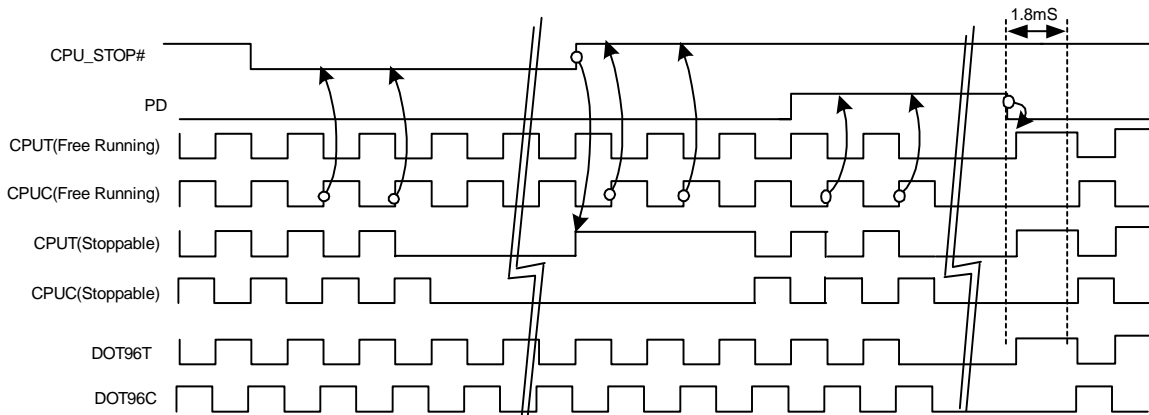
**Figure 6. CPU\_STP# Deassertion Waveform**



**Figure 7. CPU\_STP# = Driven, CPU\_PD = Driven, DOT\_PD = Driven**



**Figure 8. CPU\_STP# Assertion Waveform**



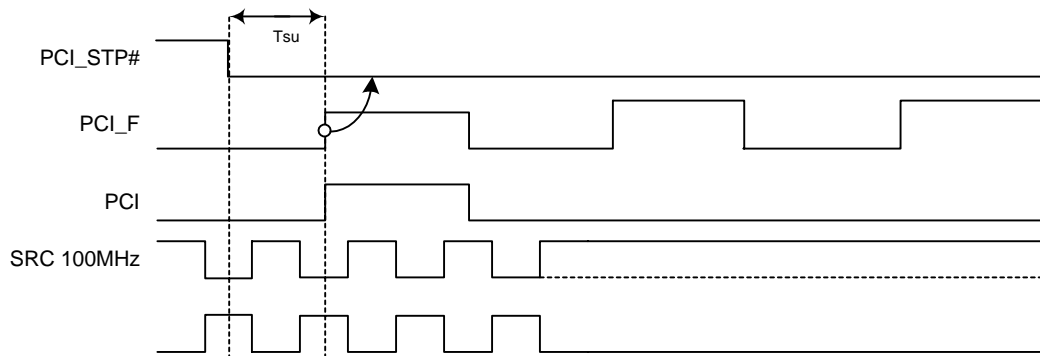
**Figure 9. CPU\_STOP# = Tri-state, CPU\_PD = Tri-state, DOT\_PD = Tri-state**

**PCI\_STOP# Assertion**

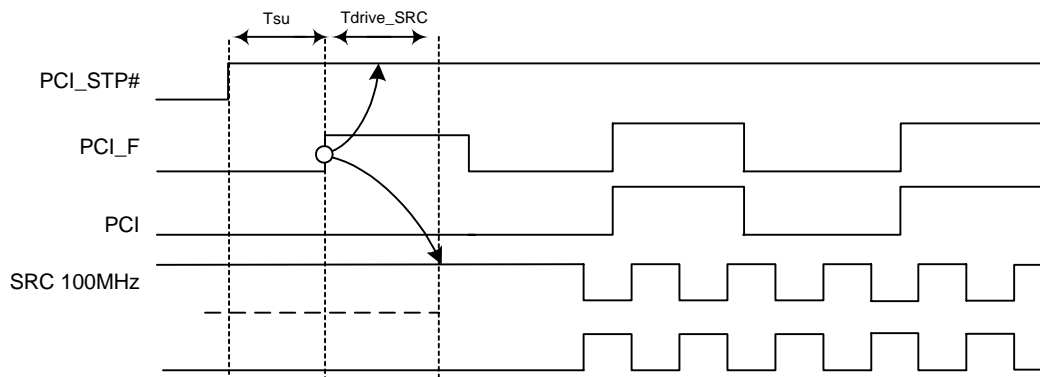
The PCI\_STOP# signal is an active LOW input used for synchronous stopping and starting the PCI outputs while the rest of the clock generator continues to function. The set-up time for capturing PCI\_STOP# going LOW is 10 ns ( $t_{SU}$ ). (See *Figure 10*.) The PCIF clocks will not be affected by this pin if their corresponding control bit in the SMBus register is set to allow them to be free running.

**PCI\_STOP# Deassertion**

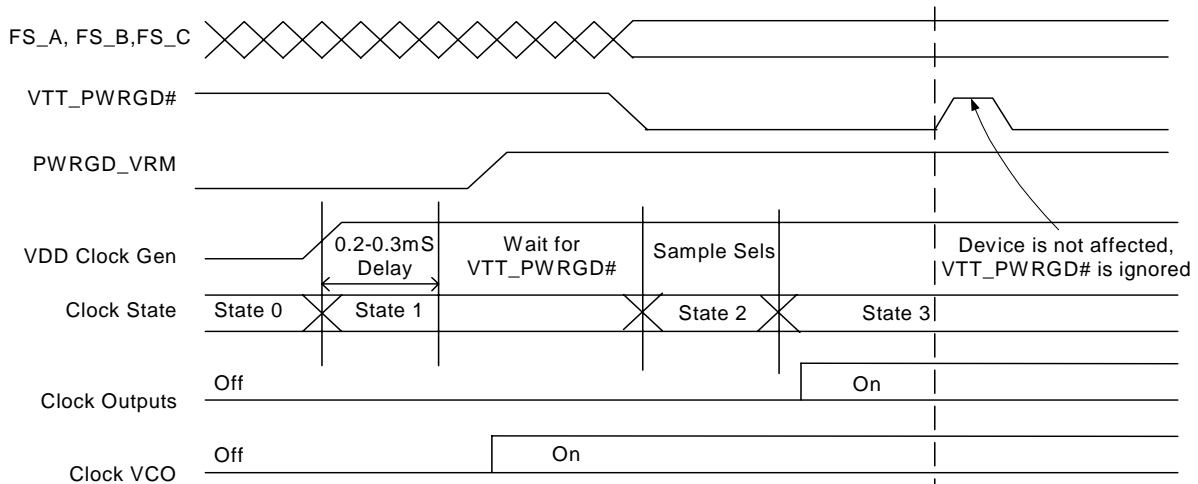
The deassertion of the PCI\_STOP# signal will cause all PCI and stoppable PCIF clocks to resume running in a synchronous manner within two PCI clock periods after PCI\_STOP# transitions to a high level.



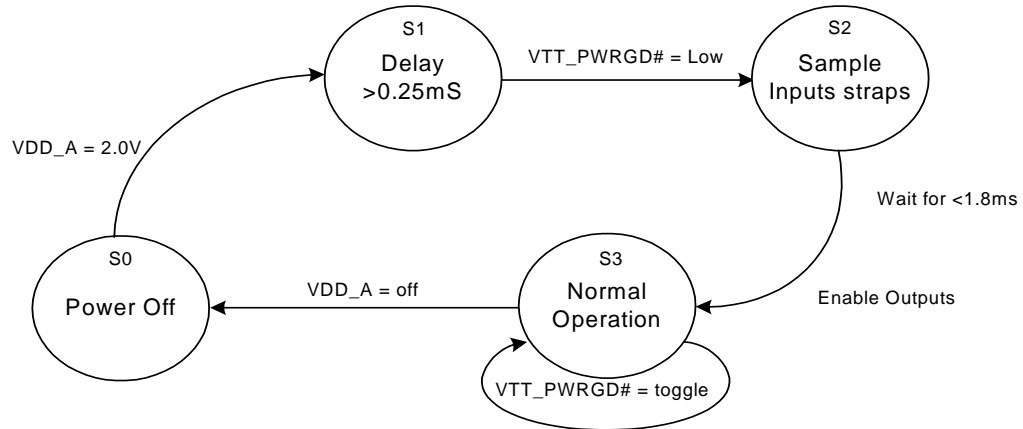
**Figure 10. PCI\_STOP# Assertion Waveform**



**Figure 11. PCI\_STOP# Deassertion Waveform**



**Figure 12. VTT\_PWRGD# Timing Diagram**



**Figure 13. Clock Generator Power-up/Run State Diagram**

**Absolute Maximum Conditions**

Parameter	Description	Condition	Min.	Max.	Unit
V <sub>DD</sub>	Core Supply Voltage		-0.5	4.6	V
V <sub>DD_A</sub>	Analog Supply Voltage		-0.5	4.6	V
V <sub>IN</sub>	Input Voltage	Relative to V <sub>SS</sub>	-0.5	V <sub>DD</sub> + 0.5	VDC
T <sub>S</sub>	Temperature, Storage	Non-functional	-65	150	°C
T <sub>A</sub>	Temperature, Operating Ambient	Functional	0	85	°C
T <sub>J</sub>	Temperature, Junction	Functional	-	150	°C
∅ <sub>JC</sub>	Dissipation, Junction to Case	Mil-STD-883E Method 1012.1	-	20	°C/W
∅ <sub>JA</sub>	Dissipation, Junction to Ambient	JEDEC (JESD 51)	-	60	°C/W
ESD <sub>HBM</sub>	ESD Protection (Human Body Model)	MIL-STD-883, Method 3015	2000	-	V
UL-94	Flammability Rating	At 1/8 in.	V-0		
MSL	Moisture Sensitivity Level		1		

**Multiple Supplies:** The Voltage on any input or I/O pin cannot exceed the power pin during power-up. Power supply sequencing is NOT required.

**DC Electrical Specifications**

Parameter	Description	Condition	Min.	Max.	Unit
All V <sub>DD</sub> S	3.3V Operating Voltage	3.3 ± 5%	3.135	3.465	V
V <sub>IL2C</sub>	Input Low Voltage	SDATA, SCLK	-	1.0	V
V <sub>IH2C</sub>	Input High Voltage	SDATA, SCLK	2.2	-	V
V <sub>IL_FS</sub>	FS_[A,B] Input Low Voltage		V <sub>SS</sub> - 0.3	0.35	V
V <sub>IH_FS</sub>	FS_[A,B] Input High Voltage		0.7	V <sub>DD</sub> + 0.5	V
V <sub>ILFS_C</sub>	FS_C Input Low Voltage		V <sub>SS</sub> - 0.3	0.35	V
V <sub>IMFS_C</sub>	FS_C Input Middle Voltage	Typical	0.7	1.7	V
V <sub>IHFS_C</sub>	FS_C Input High Voltage	Typical	2.0	V <sub>DD</sub> + 0.5	V
V <sub>IL</sub>	3.3V Input Low Voltage		V <sub>SS</sub> - 0.3	0.8	V
V <sub>IH</sub>	3.3V Input High Voltage		2.0	V <sub>DD</sub> + 0.3	V
I <sub>IL</sub>	Input Low Leakage Current	Except internal pull-up resistors, 0 < V <sub>IN</sub> < V <sub>DD</sub>	-5	5	μA
I <sub>IH</sub>	Input High Leakage Current	Except internal pull-down resistors, 0 < V <sub>IN</sub> < V <sub>DD</sub>	-	5	μA
V <sub>OL</sub>	3.3V Output Low Voltage	I <sub>OL</sub> = 1 mA	-	0.4	V
V <sub>OH</sub>	3.3V Output High Voltage	I <sub>OH</sub> = -1 mA	2.4	-	V
I <sub>OZ</sub>	High-impedance Output Current		-10	10	μA
C <sub>IN</sub>	Input Pin Capacitance		3	5	pF
C <sub>OUT</sub>	Output Pin Capacitance		3	6	pF
L <sub>IN</sub>	Pin Inductance		-	7	nH
V <sub>XIH</sub>	Xin High Voltage		0.7V <sub>DD</sub>	V <sub>DD</sub>	V
V <sub>XIL</sub>	Xin Low Voltage		0	0.3V <sub>DD</sub>	V
I <sub>DD3.3V</sub>	Dynamic Supply Current	At max. load and freq. per Figure 15	-	250	mA
I <sub>PD3.3V</sub>	Power-down Supply Current	PD asserted, Outputs Driven	-	70	mA
I <sub>PD3.3V</sub>	Power-down Supply Current	PD asserted, Outputs Tri-state	-	5	mA

**AC Electrical Specifications**

Parameter	Description	Condition	Min.	Max.	Unit
<b>Crystal</b>					
T <sub>DC</sub>	XIN Duty Cycle	The device will operate reliably with input duty cycles up to 30/70 but the REF clock duty cycle will not be within specification	47.5	52.5	%
T <sub>PERIOD</sub>	XIN Period	When XIN is driven from an external clock source	69.841	71.0	ns
T <sub>R</sub> / T <sub>F</sub>	XIN Rise and Fall Times	Measured between 0.3V <sub>DD</sub> and 0.7V <sub>DD</sub>	–	10.0	ns
T <sub>CCJ</sub>	XIN Cycle to Cycle Jitter	As an average over 1- $\mu$ s duration	–	500	ps
L <sub>ACC</sub>	Long-term Accuracy	Measured at crossing point V <sub>OX</sub>	–	300	ppm
<b>CPU at 0.8V</b>					
T <sub>DC</sub>	CPUT and CPUC Duty Cycle	Measured at crossing point V <sub>OX</sub>	45	55	%
T <sub>PERIOD</sub>	100-MHz CPUT and CPUC Period	Measured at crossing point V <sub>OX</sub>	9.997001	10.00300	ns
T <sub>PERIOD</sub>	133-MHz CPUT and CPUC Period	Measured at crossing point V <sub>OX</sub>	7.497751	7.502251	ns
T <sub>PERIOD</sub>	166-MHz CPUT and CPUC Period	Measured at crossing point V <sub>OX</sub>	5.998201	6.001801	ns
T <sub>PERIOD</sub>	200-MHz CPUT and CPUC Period	Measured at crossing point V <sub>OX</sub>	4.998500	5.001500	ns
T <sub>PERIODSS</sub>	100-MHz CPUT and CPUC Period, SSC	Measured at crossing point V <sub>OX</sub>	9.997001	10.05327	ns
T <sub>PERIODSS</sub>	133-MHz CPUT and CPUC Period, SSC	Measured at crossing point V <sub>OX</sub>	7.497751	7.539950	ns
T <sub>PERIODSS</sub>	166-MHz CPUT and CPUC Period, SSC	Measured at crossing point V <sub>OX</sub>	5.998201	6.031960	ns
T <sub>PERIODSS</sub>	200-MHz CPUT and CPUC Period, SSC	Measured at crossing point V <sub>OX</sub>	4.998500	5.026634	ns
T <sub>PERIODAbs</sub>	100-MHz CPUT and CPUC Absolute period	Measured at crossing point V <sub>OX</sub>	9.912001	10.08800	ns
T <sub>PERIODAbs</sub>	133-MHz CPUT and CPUC Absolute period	Measured at crossing point V <sub>OX</sub>	7.412751	7.587251	ns
T <sub>PERIODAbs</sub>	166-MHz CPUT and CPUC Absolute period	Measured at crossing point V <sub>OX</sub>	5.913201	6.086801	ns
T <sub>PERIODAbs</sub>	200-MHz CPUT and CPUC Absolute period	Measured at crossing point V <sub>OX</sub>	4.913500	5.086500	ns
T <sub>PERIODSSAbs</sub>	100-MHz CPUT and CPUC Absolute period, SSC	Measured at crossing point V <sub>OX</sub>	9.912001	10.13827	ns
T <sub>PERIODSSAbs</sub>	133-MHz CPUT and CPUC Absolute period, SSC	Measured at crossing point V <sub>OX</sub>	7.412751	7.624950	ns
T <sub>PERIODSSAbs</sub>	166-MHz CPUT and CPUC Absolute period, SSC	Measured at crossing point V <sub>OX</sub>	5.913201	6.116960	ns
T <sub>PERIODSSAbs</sub>	200-MHz CPUT and CPUC Absolute period, SSC	Measured at crossing point V <sub>OX</sub>	4.913500	5.111634	ns
T <sub>CCJ</sub>	CPUT/C Cycle to Cycle Jitter	Measured at crossing point V <sub>OX</sub>	–	85 <sup>[1]</sup>	ps
T <sub>CCJ2</sub>	CPU2_ITP Cycle to Cycle Jitter	Measured at crossing point V <sub>OX</sub>	–	125	ps
L <sub>ACC</sub>	Long-term Accuracy	Measured at crossing point V <sub>OX</sub>	–	300	ppm
T <sub>SKEW2</sub>	CPU2_ITP to CPU0 Clock Skew	Measured at crossing point V <sub>OX</sub>	–	150	ps
T <sub>R</sub> / T <sub>F</sub>	CPUT and CPUC Rise and Fall Time	Measured from V <sub>OL</sub> = 0.175 to V <sub>OH</sub> = 0.525V	175 <sup>[1]</sup>	700	ps
T <sub>RFM</sub>	Rise/Fall Matching	Determined as a fraction of 2*(T <sub>R</sub> – T <sub>F</sub> )/(T <sub>R</sub> + T <sub>F</sub> )	–	20	%
$\Delta$ T <sub>R</sub>	Rise Time Variation		–	125	ps
$\Delta$ T <sub>F</sub>	Fall Time Variation		–	125	ps
V <sub>HIGH</sub>	Voltage High	Math averages <i>Figure 15</i>	660	850	mV

**Note:**

 1. Measured at typical condition. V<sub>DD</sub> = 3.3V, Temp=25°C.



**AC Electrical Specifications** (continued)

Parameter	Description	Condition	Min.	Max.	Unit
V <sub>LOW</sub>	Voltage Low	Math averages <i>Figure 15</i>	-150	-	mV
V <sub>OX</sub>	Crossing Point Voltage at 0.7V Swing		250 <sup>[1]</sup>	550	mV
V <sub>OVS</sub>	Maximum Overshoot Voltage		-	V <sub>HIGH</sub> + 0.3	V
V <sub>UDS</sub>	Minimum Undershoot Voltage		-0.3	-	V
V <sub>RB</sub>	Ring Back Voltage	See <i>Figure 15</i> . Measure SE	-	0.2	V
<b>SRC at 0.8V</b>					
T <sub>DC</sub>	SRCT and SRCC Duty Cycle	Measured at crossing point V <sub>OX</sub>	45	55	%
T <sub>PERIOD</sub>	100-MHz SRCT and SRCC Period	Measured at crossing point V <sub>OX</sub>	9.997001	10.00300	ns
T <sub>PERIODSS</sub>	100-MHz SRCT and SRCC Period, SSC	Measured at crossing point V <sub>OX</sub>	9.997001	10.05327	ns
T <sub>PERIODAbs</sub>	100-MHz SRCT and SRCC Absolute Period	Measured at crossing point V <sub>OX</sub>	9.872001	10.12800	ns
T <sub>PERIODSSAbs</sub>	100-MHz SRCT and SRCC Absolute Period, SSC	Measured at crossing point V <sub>OX</sub>	9.872001	10.17827	ns
T <sub>SKEW</sub>	Any SRCT/C to SRCT/C Clock Skew	Measured at crossing point V <sub>OX</sub>	-	100	ps
T <sub>CCJ</sub>	SRCT/C Cycle to Cycle Jitter	Measured at crossing point V <sub>OX</sub>	-	125	ps
L <sub>ACC</sub>	SRCT/C Long Term Accuracy	Measured at crossing point V <sub>OX</sub>	-	300	ppm
T <sub>R</sub> / T <sub>F</sub>	SRCT and SRCC Rise and Fall Time	Measured from V <sub>OL</sub> = 0.175 to V <sub>OH</sub> = 0.525V	175 <sup>[1]</sup>	700 <sup>[1]</sup>	ps
T <sub>RFM</sub>	Rise/Fall Matching	Determined as a fraction of 2*(T <sub>R</sub> - T <sub>F</sub> )/(T <sub>R</sub> + T <sub>F</sub> )	-	20	%
ΔT <sub>R</sub>	Rise Time Variation		-	125	ps
ΔT <sub>F</sub>	Fall Time Variation		-	125	ps
V <sub>HIGH</sub>	Voltage High	Math averages <i>Figure 15</i>	660	850	mV
V <sub>LOW</sub>	Voltage Low	Math averages <i>Figure 15</i>	-150	-	mV
V <sub>OX</sub>	Crossing Point Voltage at 0.7V Swing		250	550	mV
V <sub>OVS</sub>	Maximum Overshoot Voltage		-	V <sub>HIGH</sub> + 0.3	V
V <sub>UDS</sub>	Minimum Undershoot Voltage		-0.3	-	V
V <sub>RB</sub>	Ring Back Voltage	See <i>Figure 15</i> . Measure SE	-	0.2	V
<b>DOT96 at 0.7V</b>					
T <sub>DC</sub>	DOT96T and DOT96C Duty Cycle	Measured at crossing point V <sub>OX</sub>	45	55	%
T <sub>PERIOD</sub>	DOT96T and DOT96C Period	Measured at crossing point V <sub>OX</sub>	10.41354	10.41979	ns
T <sub>PERIODAbs</sub>	DOT96T and DOT96C Absolute Period	Measured at crossing point V <sub>OX</sub>	10.16354	10.66979	ns
T <sub>CCJ</sub>	DOT96T/C Cycle to Cycle Jitter	Measured at crossing point V <sub>OX</sub>	-	250	ps
L <sub>ACC</sub>	DOT96T/C Long Term Accuracy	Measured at crossing point V <sub>OX</sub>	-	300	ppm
T <sub>R</sub> / T <sub>F</sub>	DOT96T and DOT96C Rise and Fall Time	Measured from V <sub>OL</sub> = 0.175 to V <sub>OH</sub> = 0.525V	175 <sup>[1]</sup>	700	ps
T <sub>RFM</sub>	Rise/Fall Matching	Determined as a fraction of 2*(T <sub>R</sub> - T <sub>F</sub> )/(T <sub>R</sub> + T <sub>F</sub> )	-	20	%
ΔT <sub>R</sub>	Rise Time Variation		-	125	ps
ΔT <sub>F</sub>	Fall Time Variation		-	125	ps
V <sub>HIGH</sub>	Voltage High	Math averages <i>Figure 15</i>	660	850	mV
V <sub>LOW</sub>	Voltage Low	Math averages <i>Figure 15</i>	-150	-	mV
V <sub>OX</sub>	Crossing Point Voltage at 0.7V Swing		250	550	mV

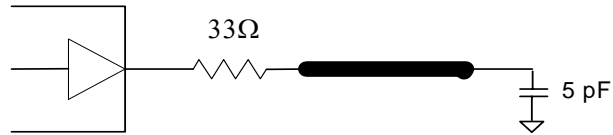
**AC Electrical Specifications** (continued)

Parameter	Description	Condition	Min.	Max.	Unit
V <sub>OVS</sub>	Maximum Overshoot Voltage		–	V <sub>HIGH</sub> + 0.3	V
V <sub>UDS</sub>	Minimum Undershoot Voltage		–0.3	–	V
V <sub>RB</sub>	Ring Back Voltage	See Figure 15. Measure SE	–	0.2	V
<b>PCI/PCIF at 3.3V</b>					
T <sub>DC</sub>	PCI Duty Cycle	Measurement at 1.5V	45	55	%
T <sub>PERIOD</sub>	Spread Disabled PCIF/PCI Period	Measurement at 1.5V	29.99100	30.00900	ns
T <sub>PERIODSS</sub>	Spread Enabled PCIF/PCI Period, SSC	Measurement at 1.5V	29.9910	30.15980	ns
T <sub>PERIODAbs</sub>	Spread Disabled PCIF/PCI Period	Measurement at 1.5V	29.49100	30.50900	ns
T <sub>PERIODSSAbs</sub>	Spread Enabled PCIF/PCI Period, SSC	Measurement at 1.5V	29.49100	30.65980	ns
T <sub>HIGH</sub>	PCIF and PCI high time	Measurement at 2.4V	12.0	–	ns
T <sub>LOW</sub>	PCIF and PCI low time	Measurement at 0.4V	12.0	–	ns
T <sub>R</sub> / T <sub>F</sub>	PCIF/PCI rising and falling Edge Rate	Measured between 0.8V and 2.0V	1.0	4.0	V/ns
T <sub>SKEW</sub>	Any PCI clock to Any PCI clock Skew	Measurement at 1.5V	–	500	ps
T <sub>CCJ</sub>	PCIF and PCI Cycle to Cycle Jitter	Measurement at 1.5V	–	500	ps
L <sub>ACC</sub>	PCIF/PCI Long Term Accuracy	Measured at crossing point V <sub>Ox</sub>	–	300	ppm
<b>48_M at 3.3V</b>					
T <sub>DC</sub>	Duty Cycle	Measurement at 1.5V	45	55	%
T <sub>PERIOD</sub>	Period	Measurement at 1.5V	20.83125	20.83542	ns
T <sub>PERIODAbs</sub>	Absolute Period	Measurement at 1.5V	20.48125	21.18542	ns
T <sub>HIGH</sub>	48_M High time	Measurement at 2.4V	8.09	11.3	ns
T <sub>LOW</sub>	48_M Low time	Measurement at 0.4V	7.694	11.3	ns
T <sub>R</sub> / T <sub>F</sub>	Rising and Falling Edge Rate	Measured between 0.8V and 2.0V	1.0	4.0	V/ns
T <sub>CCJ</sub>	Cycle to Cycle Jitter	Measurement at 1.5V	–	350	ps
L <sub>ACC</sub>	48M Long Term Accuracy	Measured at crossing point V <sub>Ox</sub>	–	300	ppm
<b>REF at 3.3V</b>					
T <sub>DC</sub>	REF Duty Cycle	Measurement at 1.5V	45	55	%
T <sub>PERIOD</sub>	REF Period	Measurement at 1.5V	69.8203	69.8622	ns
T <sub>PERIODAbs</sub>	REF Absolute Period	Measurement at 1.5V	68.82033	70.86224	ns
T <sub>R</sub> / T <sub>F</sub>	REF Rising and Falling Edge Rate	Measured between 0.8V and 2.0V	1.0	4.0	V/ns
T <sub>SKEW</sub>	REF Clock to REF Clock	Measurement at 1.5V	–	500	ps
T <sub>CCJ</sub>	REF Cycle to Cycle Jitter	Measurement at 1.5V	–	1000	ps
L <sub>ACC</sub>	Long Term Accuracy	Measurement at 1.5V	–	300	ppm
<b>ENABLE/DISABLE and SET-UP</b>					
T <sub>STABLE</sub>	Clock Stabilization from Power-up		–	1.8	ms
T <sub>SS</sub>	Stopclock Set-up Time		10.0	–	ns
T <sub>SH</sub>	Stopclock Hold Time		0	–	ns

## Test and Measurement Set-up

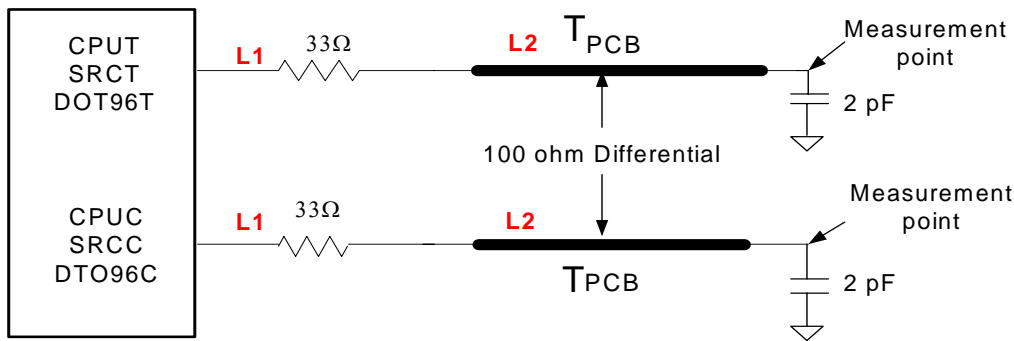
### For PCI Single-ended Signals and Reference

The following diagram shows the test load configuration of single-ended PCI, USB output signals.

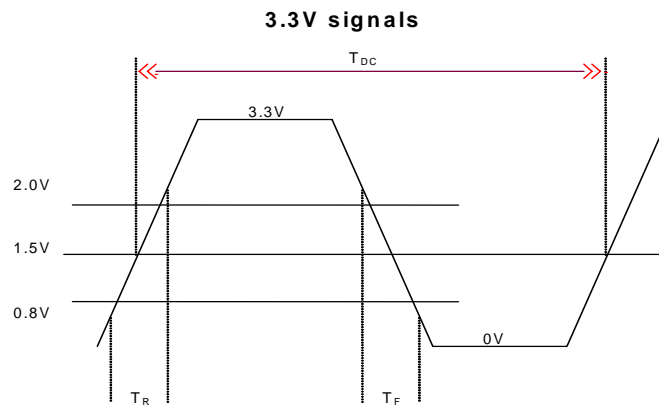


**Figure 14. Single-ended PCI, USB Load Configuration**

The following diagram shows the test load configuration for the differential CPU and SRC outputs.



**Figure 15. 0.7V Differential Load Configuration**



**Figure 16. Single-ended Output Signals (for AC Parameters Measurement)**

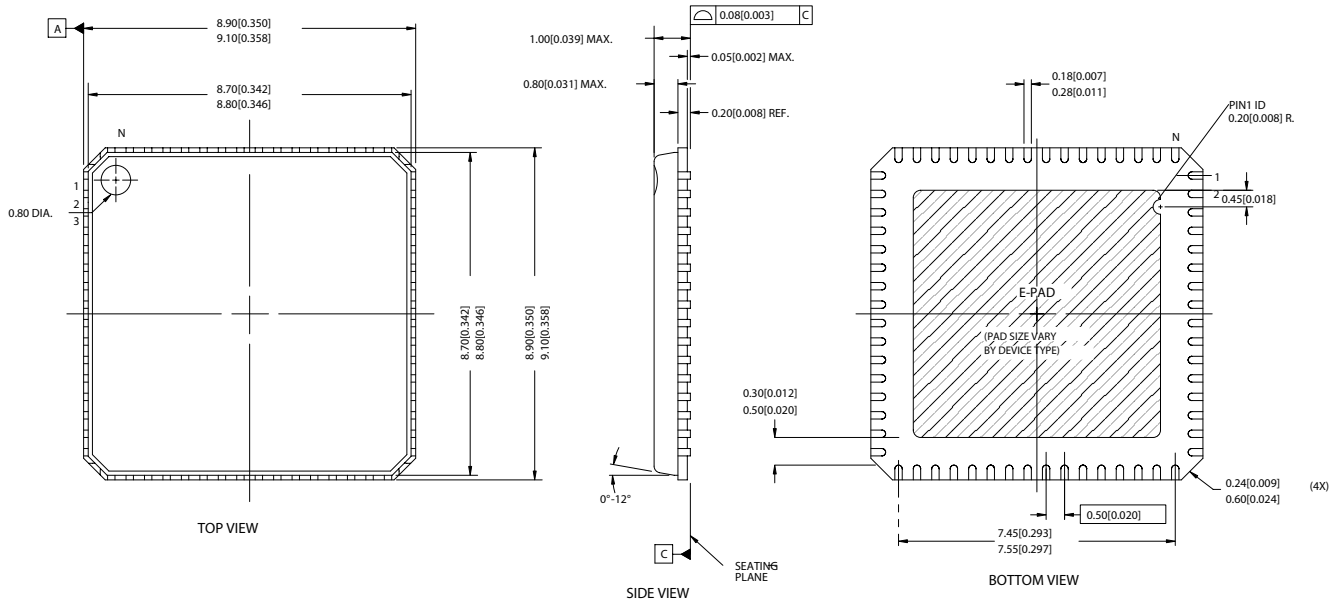
## Ordering Information

Part Number	Package Type	Product Flow
<b>Lead-free</b>		
CY28446LFXC	64-pin QFN	Commercial, 0° to 70°C
CY28446LFXCT	64-pin QFN—Tape and Reel	Commercial, 0° to 70°C

Package Diagram

64-Lead QFN 9 x 9 mm (Punch Version) LF64A

DIMENSIONS IN MM[INCHES] MIN. MAX.  
 REFERENCE JEDEC MO-220  
 WEIGHT: 0.2 GRAMS



51-85215-\*\*

Purchase of I2C components from Cypress or one of its sublicensed Associated Companies conveys a license under the Philips I2C Patent Rights to use these components in an I2C system, provided that the system conforms to the I2C Standard Specification as defined by Philips.

Intel is a registered trademark of Intel Corporation. All products and company names mentioned in this document may be the trademarks of their respective holders.

**Document History Page**

Document Title: CY28446 Clock Generator for Intel® Calistoga Chipset				
Document Number: 001-00168				
REV.	ECN NO.	Issue Date	Orig. of Change	Description of Change
**	366781	See ECN	RGL	New data sheet
*A	385257	See ECN	RGL	Modify Control register byte 4 and 6 Delete 96_100MHz LCD clock AC timing spec from AC Electrical specifications table Modify figure 15 for lower differential buffer Change pin 33 from IREF to VSS_SRC Update I <sub>DD</sub> , I <sub>PD</sub> number in DC Electrical Specifications table Updated single-ended PCI, USB loading config. diagram
*B	391184	See ECN	RGL	Minor Change: corrected the letter suffix for QFN package
*C	402318	See ECN	XLZ	Modify Control register byte 6, 7, 9 Update DC and AC Electrical Specifications table
*D	436731	See ECN	RGL	Updated Control register bytes 0,1 and 7 Updated AC Electrical Specifications table Removed preliminary status