

DATA SHEET

EP13

EP cores and accessories

Supersedes data of February 2002

2004 Sep 01

CORE SETS

Effective core parameters

SYMBOL	PARAMETER	VALUE	UNIT
$\Sigma(l/A)$	core factor (C1)	1.24	mm ⁻¹
V_e	effective volume	472	mm ³
l_e	effective length	24.2	mm
A_e	effective area	19.5	mm ²
A_{min}	minimum area	14.9	mm ²
m	mass of core set	≈ 4.7	g

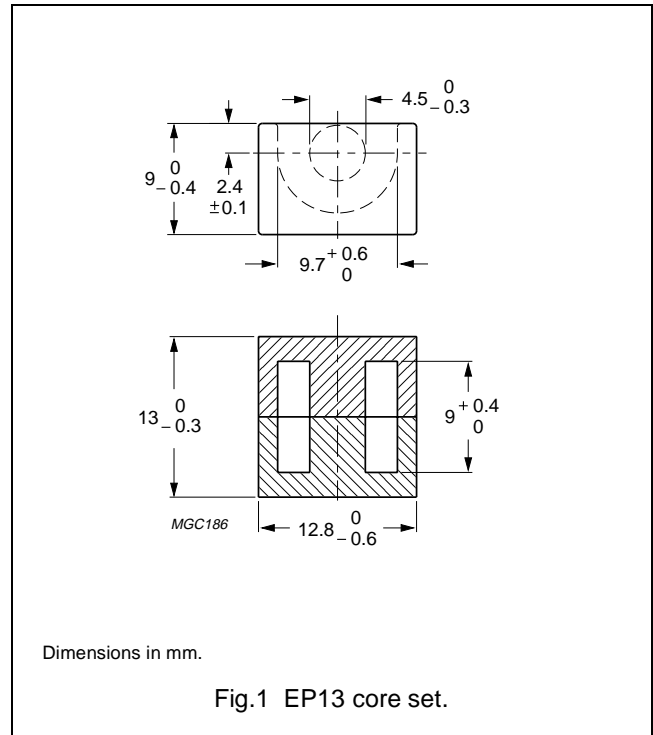

Core sets for filter applications

Clamping force for A_L measurements, 30 ±10 N.

GRADE	A_L (nH)	μ_e	AIR GAP (μ m)	TYPE NUMBER
3D3	63 ±3%	≈ 62	≈ 500	EP13-3D3-A63
	100 ±3%	≈ 100	≈ 270	EP13-3D3-A100
	160 ±3%	≈ 160	≈ 140	EP13-3D3-A160
	670 ±25%	≈ 660	≈ 0	EP13-3D3
3H3	63 ±3%	≈ 62	≈ 540	EP13-3H3-A63
	100 ±3%	≈ 99	≈ 300	EP13-3H3-A100
	160 ±3%	≈ 158	≈ 170	EP13-3H3-A160
	1500 ±25%	≈ 1460	≈ 0	EP13-3H3
3B46 des	2150 ±25%	≈ 2090	≈ 0	EP13-3B46

Core sets for general purpose transformers and power applicationsClamping force for A_L measurements, 30 ± 10 N.

GRADE	A_L (nH)	μ_e	AIR GAP (μm)	TYPE NUMBER
3C81	40 $\pm 3\%$	≈ 40	≈ 1000	EP13-3C81-E40
	63 $\pm 3\%$	≈ 62	≈ 540	EP13-3C81-A63
	100 $\pm 3\%$	≈ 99	≈ 300	EP13-3C81-A100
	160 $\pm 3\%$	≈ 158	≈ 170	EP13-3C81-A160
	250 $\pm 5\%$	≈ 247	≈ 100	EP13-3C81-A250
	1700 $\pm 25\%$	≈ 1680	≈ 0	EP13-3C81
3C91 des	1700 $\pm 25\%$	≈ 1680	≈ 0	EP13-3C91
3C94	40 $\pm 3\%$	≈ 40	≈ 1000	EP13-3C94-E40
	63 $\pm 3\%$	≈ 62	≈ 540	EP13-3C94-A63
	100 $\pm 3\%$	≈ 99	≈ 300	EP13-3C94-A100
	160 $\pm 3\%$	≈ 158	≈ 170	EP13-3C94-A160
	250 $\pm 5\%$	≈ 247	≈ 100	EP13-3C94-A250
	1650 $\pm 25\%$	≈ 1630	≈ 0	EP13-3C94
3C96 des	1500 $\pm 25\%$	≈ 1480	≈ 0	EP13-3C96
3F3	40 $\pm 3\%$	≈ 40	≈ 1000	EP13-3F3-E40
	63 $\pm 3\%$	≈ 62	≈ 540	EP13-3F3-A63
	100 $\pm 3\%$	≈ 99	≈ 300	EP13-3F3-A100
	160 $\pm 3\%$	≈ 158	≈ 170	EP13-3F3-A160
	250 $\pm 5\%$	≈ 247	≈ 100	EP13-3F3-A250
	1325 $\pm 25\%$	≈ 1310	≈ 0	EP13-3F3
3F35 prot	1100 $\pm 25\%$	≈ 1090	≈ 0	EP13-3F35

Core sets of high permeability gradesClamping force for A_L measurements, 30 ± 10 N.

GRADE	A_L (nH)	μ_e	AIR GAP (μm)	TYPE NUMBER
3E27	4600 $\pm 25\%$	≈ 4540	≈ 0	EP13-3E27
3E5	7000 +40/-30%	≈ 6900	≈ 0	EP13-3E5
3E55 des	100 $\pm 3\%$	≈ 99	≈ 310	EP13-3E55-A100
	160 $\pm 3\%$	≈ 158	≈ 180	EP13-3E55-A160
	250 $\pm 5\%$	≈ 247	≈ 110	EP13-3E55-A250
	315 $\pm 5\%$	≈ 311	≈ 80	EP13-3E55-A315
	400 $\pm 8\%$	≈ 395	≈ 65	EP13-3E55-A400
	630 $\pm 15\%$	≈ 622	≈ 40	EP13-3E55-A630
	7000 +40/-30%	≈ 6900	≈ 0	EP13-3E55
3E6	8500 +40/-30%	≈ 8400	≈ 0	EP13-3E6

Properties of core sets under power conditions

GRADE	B (mT) at	CORE LOSS (W) at			
	H = 250 A/m; f = 25 kHz; T = 100 °C	f = 25 kHz; \hat{B} = 200 mT; T = 100 °C	f = 100 kHz; \hat{B} = 100 mT; T = 100 °C	f = 100 kHz; \hat{B} = 200 mT; T = 100 °C	f = 400 kHz; \hat{B} = 50 mT; T = 100 °C
3C81	≥315	≤ 0.1	–	–	–
3C91	≥315	–	≤ 0.03 ⁽¹⁾	≤ 0.17 ⁽¹⁾	–
3C94	≥320	–	≤ 0.04	≤ 0.22	–
3C96	≥340	–	≤ 0.03	≤ 0.17	≤ 0.075
3F35	≥300	–	–	–	≤ 0.04
3F3	≥315	–	≤ 0.05	–	≤ 0.1

Properties of core sets under power conditions (continued)

GRADE	B (mT) at	CORE LOSS (W) at			
	H = 250 A/m; f = 25 kHz; T = 100 °C	f = 500 kHz; \hat{B} = 50 mT; T = 100 °C	f = 500 kHz; \hat{B} = 100 mT; T = 100 °C	f = 1 MHz; \hat{B} = 30 mT; T = 100 °C	f = 3 MHz; \hat{B} = 10 mT; T = 100 °C
3C81	≥315	–	–	–	–
3C91	≥315	–	–	–	–
3C94	≥320	–	–	–	–
3C96	≥340	≤ 0.15	–	–	–
3F35	≥300	≤ 0.06	≤ 0.45	–	–
3F3	≥315	–	–	–	–

Note

1. Measured at 60 °C.

COIL FORMERS

General data

PARAMETER	SPECIFICATION
Coil former material	phenolformaldehyde (PF), glass-reinforced, flame retardant in accordance with "UL 94V-0"; UL file number: E41429(M)
Pin material	copper clad steel, tin (Sn) plated
Maximum operating temperature	180 °C, "IEC 60085", class H
Resistance to soldering heat	"IEC 60068-2-20", Part 2, Test Tb, method 1B: 350 °C, 3.5 s
Solderability	"IEC 60068-2-20", Part 2, Test Ta, method 1: 235 °C, 2 s

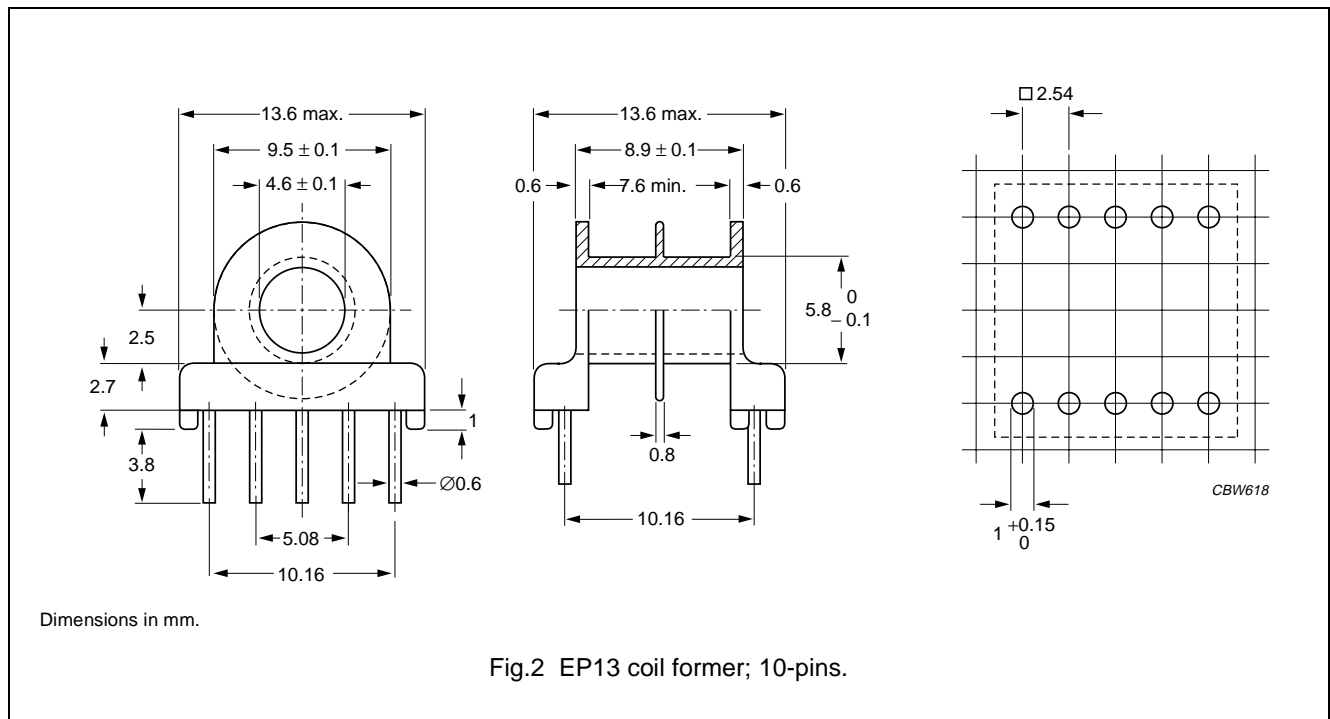

Winding data for 10-pins EP13 coil former

NUMBER OF SECTIONS	WINDING AREA (mm ²)	MINIMUM WINDING WIDTH (mm)	AVERAGE LENGTH OF TURN (mm)	TYPE NUMBER
1	13.6	7.6	23.8	CSH-EP13-1S-10P
2	2 × 6.1	2 × 3.4	23.8	CSH-EP13-2S-10P

General data CSHS-EP13-1S-10P-T

PARAMETER	SPECIFICATION
Coil former material	phenolformaldehyde (PF), glass-reinforced, flame retardant in accordance with "UL 94V-0"; UL file number E41429 (M)
Pin material	copper-clad steel, tin-lead alloy (SnPb) plated, transition to lead-free (Sn) ongoing.
Maximum operating temperature	155 °C, "IEC 60085", class F
Resistance to soldering heat	"IEC 60068-2-20", Part 2, Test Tb, method 1B, 350 °C, 3.5 s
Solderability	"IEC 60068-2-20", Part 2, Test Ta, method 1, 235 °C, 2 s

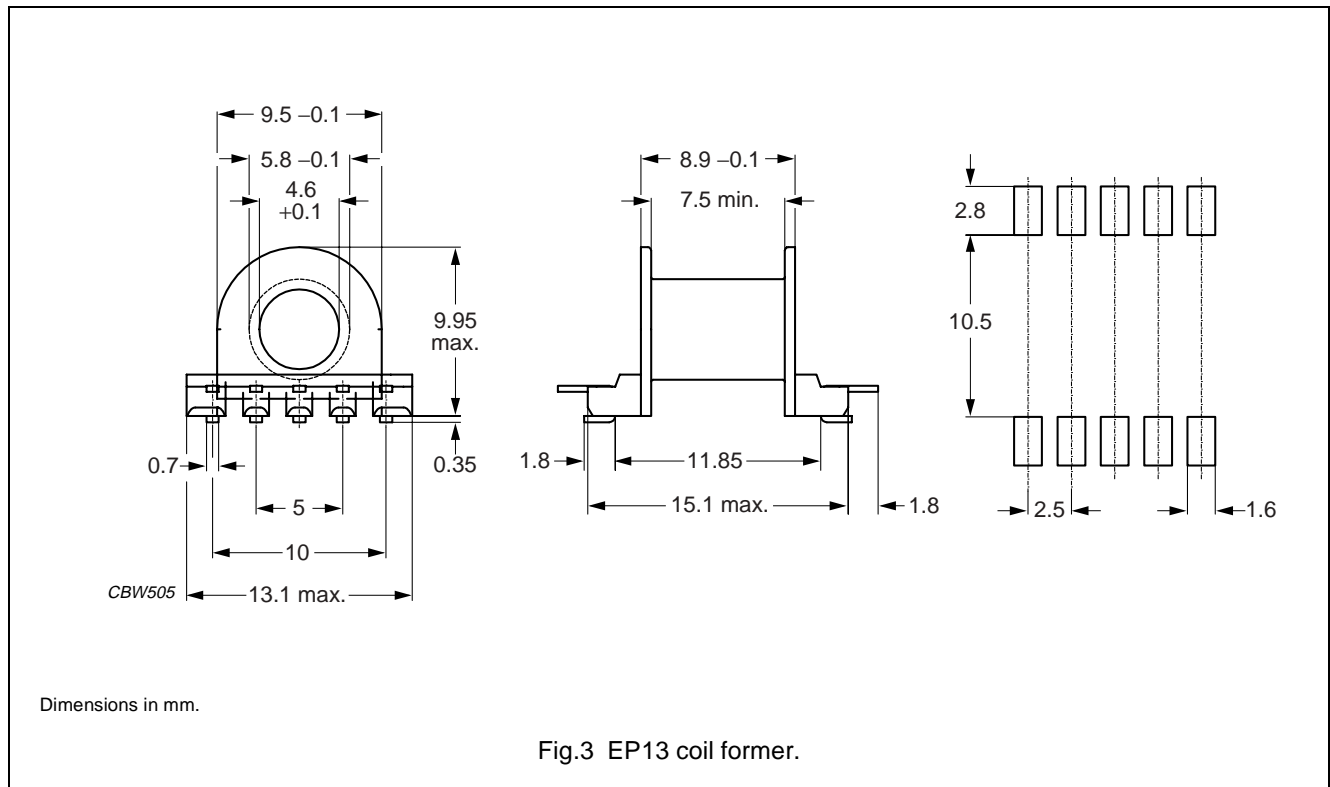

Winding data for EP13 coil former

NUMBER OF SECTIONS	MINIMUM WINDING AREA (mm ²)	NOMINAL WINDING WIDTH (mm)	AVERAGE LENGTH OF TURN (mm)	TYPE NUMBER
1	13.5	7.5	23.8	CSHS-EP13-1S-10P-T

MOUNTING PARTS

General data

ITEM	REMARKS	FIGURE	TYPE NUMBER
Clasp	copper-nickel-zinc alloy (nickel silver)	4	CLA-EP13
Spring	copper-nickel-zinc alloy (nickel silver)	5	SPR-EP13
Clip	stainless steel (CrNi); clamping force ≈ 32 N	6	CLI-EP13

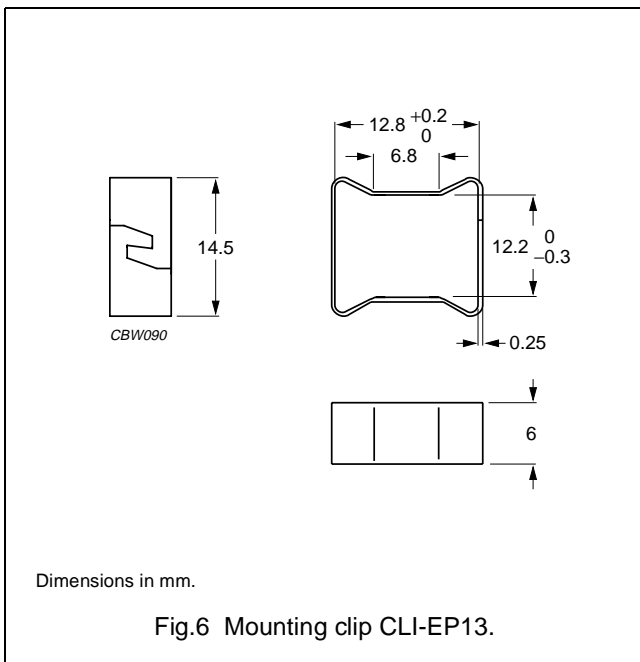
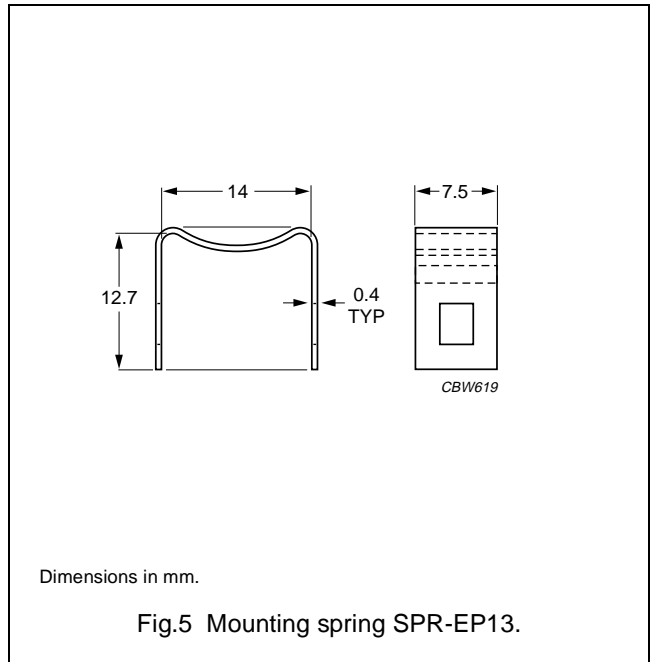
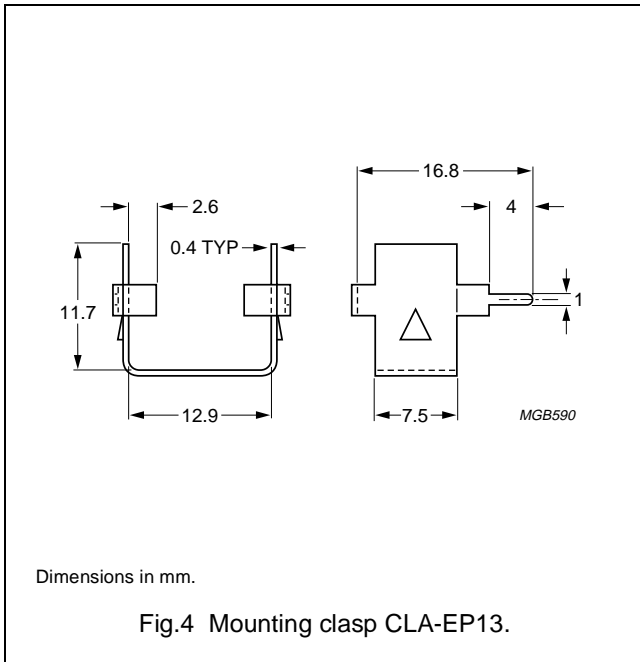



DATA SHEET STATUS DEFINITIONS

DATA SHEET STATUS	PRODUCT STATUS	DEFINITIONS
Preliminary specification	Development	This data sheet contains preliminary data. Ferroxcube reserves the right to make changes at any time without notice in order to improve design and supply the best possible product.
Product specification	Production	This data sheet contains final specifications. Ferroxcube reserves the right to make changes at any time without notice in order to improve design and supply the best possible product.

DISCLAIMER

Life support applications — These products are not designed for use in life support appliances, devices, or systems where malfunction of these products can reasonably be expected to result in personal injury. Ferroxcube customers using or selling these products for use in such applications do so at their own risk and agree to fully indemnify Ferroxcube for any damages resulting from such application.

PRODUCT STATUS DEFINITIONS

STATUS	INDICATION	DEFINITION
Prototype		These are products that have been made as development samples for the purposes of technical evaluation only. The data for these types is provisional and is subject to change.
Design-in		These products are recommended for new designs.
Preferred		These products are recommended for use in current designs and are available via our sales channels.
Support		These products are not recommended for new designs and may not be available through all of our sales channels. Customers are advised to check for availability.