

T1/CEPT/ISDN PRI INTERFACE TRANSFORMER

Reinforced Insulation Per EN 41003/EN 60950

Turns Ratio ($\pm 5\%$)

1CT:1CT & 1CT: 2CT

PARAMETER	MIN.	MAX.	UNITS
OCL (Primary)	1.2 & 1.2		mH
Capacitance ($C_{w/w}$)		15 & 15	pF
Primary DC Resistance		1.0 & 1.0	ohms
Secondary DC Resistance		1.0 & 1.7	ohms

Flammability: Materials used in the production of these units meet requirements of UL94-VO and IEC 695-2-2 needle flame test.

3000 V_{RMS} Isolation (Hi-Pot)

Parts shipped in anti-static tubes.

Primary Pins 1-3 & 6-8

Tape and Reel available.

PHYSICAL DIMENSIONS All dimensions in inches (mm)

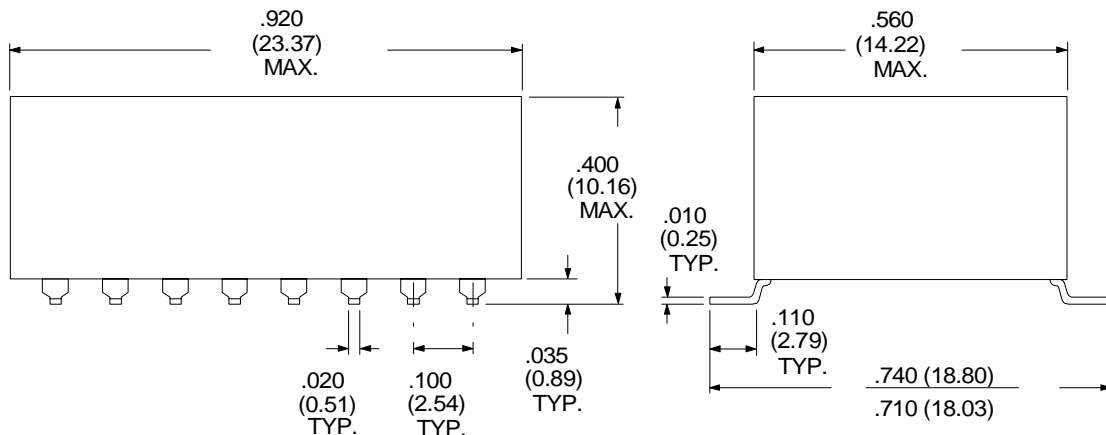

Schematic Diagram

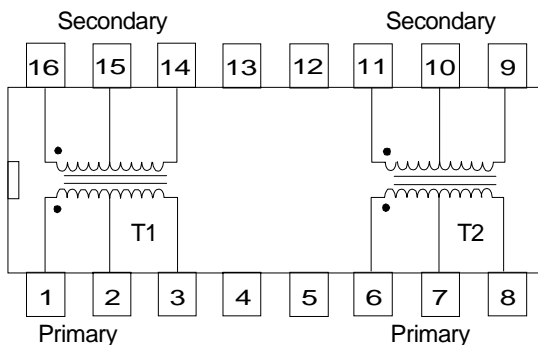

RHOMBUS P/N: **T-15810**

CUST P/N:

NAME:

DATE: **5/28/99**

SHEET: 1 OF 1