

These components are RoHS compliant

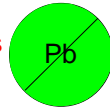

SSA-005 Miniature Opto Array

BLUE LEDS NOW AVAILABLE

SSA-005 is an eight element plastic moulding designed for use with miniature T 3/4 size opto electronic components. The resulting array is of minimum size at 0.1 inch pitch in a compact housing. The housing is equally suitable for visible and infrared products.

- Black housing ideal for LED presentation.
- Choice of Red, Orange, Yellow Green or Blue LEDs in any colour combination.
- Infra red emitters and sensors may be narrow angle lenses or flat wide angle lenses.
- Leads are on a double 0.1 inch matrix
- Arrays will end stack maintaining 0.1" pitch.



MECHANICAL DATA

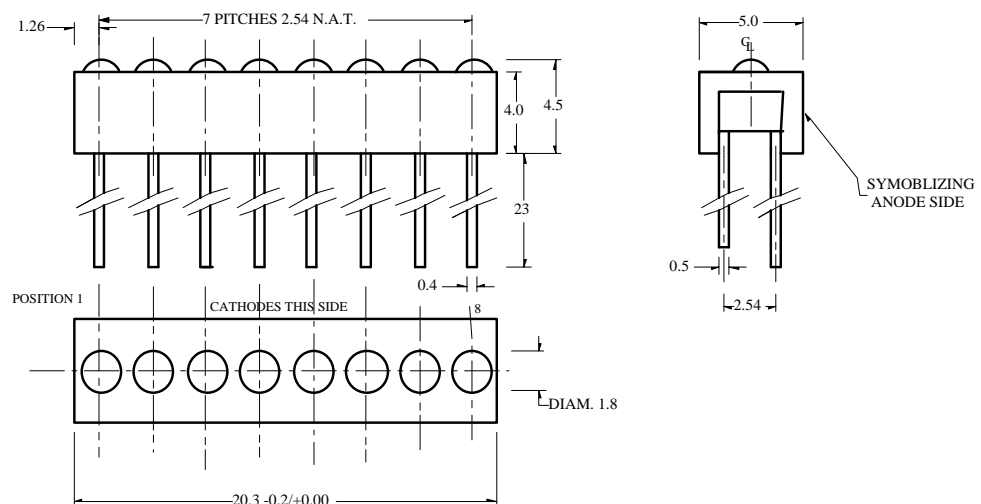

BEDFORD OPTO TECHNOLOGY LTD
1, BIGGAR BUSINESS PARK BIGGAR, ML12 6FX
Tel: +44 (0) 1899 221221 Fax: +44 (0) 1899 221009
Website: bot.co.uk E-mail: bill@bot.co.uk

These
components
are RoHS
compliant

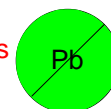

ABSOLUTE MAXIMUM RATINGS (T_A = 25°C)

	Red	Others
REVERSE VOLTAGE	6 Volts	6 Volts
CONTINUOUS FORWARD CURRENT	50mA	30 mA
POWER DISSIPATION T _a < 55 C	100mW	100 mW
JUNCTION TEMP	100°C	
STORAGE TEMP	-55 to +100°C	
THERMAL RESISTANCE	450 K/W	

	Blue
REVERSE VOLTAGE	5 Volts
FORWARD CURRENT	30 mA
POWER DISSIPATION	120mW
OPERATING TEMP °C	-20 to+80
STORAGE TEMP °C	-30 to+100

SOLDERING TEMPERATURE (3secs max 2mm from body) ALL TYPES	260 °C max
--	------------

OPTO ELECTRONIC DATA (T_a = 25°C)

COLOUR		Luminous Intensity If = 10mA mcd	Peak Wavelength nm	Forward Voltage If = 20mA volts
RED	min	1	-	-
	typ	1.5	660	1.6
ORANGE	min	4	-	-
	typ	5	630	2
YELLOW	min	2.5	-	-
	typ	8	585	2.4
GREEN	min	4	-	-
	typ	12	565	2.4
	ma	-	-	3
BLUE	Min	21	-	-
	Typ	38	430	3.8

ORDERING INFORMATION

SSA005 X ----- Y
Pos1 Pos 8

X OR Y = R = Red
O = Orange
Y = Yellow
G = Green
B = Blank
BL=Blue

Custom part numbers will be allocated
to describe mixed LED combination.

BEDFORD OPTO TECHNOLOGY LTD
1,BIGGAR BUSINESS PARK, BIGGAR, ML12 6NR
Tel: +44 (0) 1899 221221 Fax: +44 (0) 1899 221009
Website: bot.co.uk E-mail: bill@bot.co.uk