

▶ PRODUCT OVERVIEW

The MV78200 is a dual-core, high-performance, low-power, highly integrated processor with the Marvell® Sheeva™ ARMv5TE-compliant CPU core. Built on Marvell's innovative Discovery™ system controller platform, the MV78200 is a complete system-on-chip (SoC) solution. Optimized for low power operation, the MV78200 is ideally suited to a wide range of applications ranging from sophisticated routers, switches and wireless base stations to high-volume laser printers applications.

The MV78200 offers unparalleled integration that makes system design simple and cost efficient. The SoC integrates:

- High-performance dual-issue CPU with Vector Floating Point (VFP) support
- 800 MHz and 1 Ghz operating speed
- 32KB-Instruction and 32KB-Data 4-way, set-associative L1 cache per core
- 512KB unified 8-way, set-associative L2 cache per core
- 40/72-bit high bandwidth DDR2 memory interface (up to 800 MHz data rate)
- Four Gigabit Ethernet MACs with interface options
- Two PCI-Express ports (x4 or Quad x1)
- Three USB 2.0 ports with integrated PHYs
- Two SATA 2.0 ports with integrated PHYs
- Security engine
- Pin-compatible with single-core (MV78100) version

The innovative, on-chip crossbar architecture with any-to-any connectivity enables concurrent transactions among multiple units that results in high system throughput allowing system designers to create high-performance scalable systems. Tightly integrated CPU and memory controller significantly improves application performance.

▶ BLOCK DIAGRAM

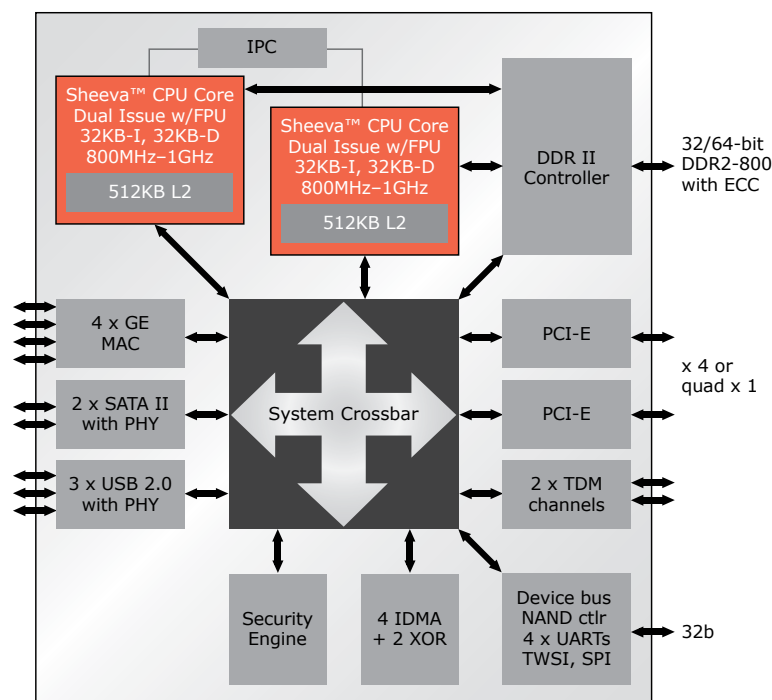

Fig 1. MV78200 SoC Block Diagram

▶ **COMPREHENSIVE DEVELOPMENT TOOLS**

Marvell offers complete development platforms for Discovery Innovation Series SoCs, enabling customers to start system development without waiting for their own hardware. Development platforms are available. Complete reference design platforms, including software drivers and board support packages for VxWorks, BSD and Linux, accelerate customer product development cycles.

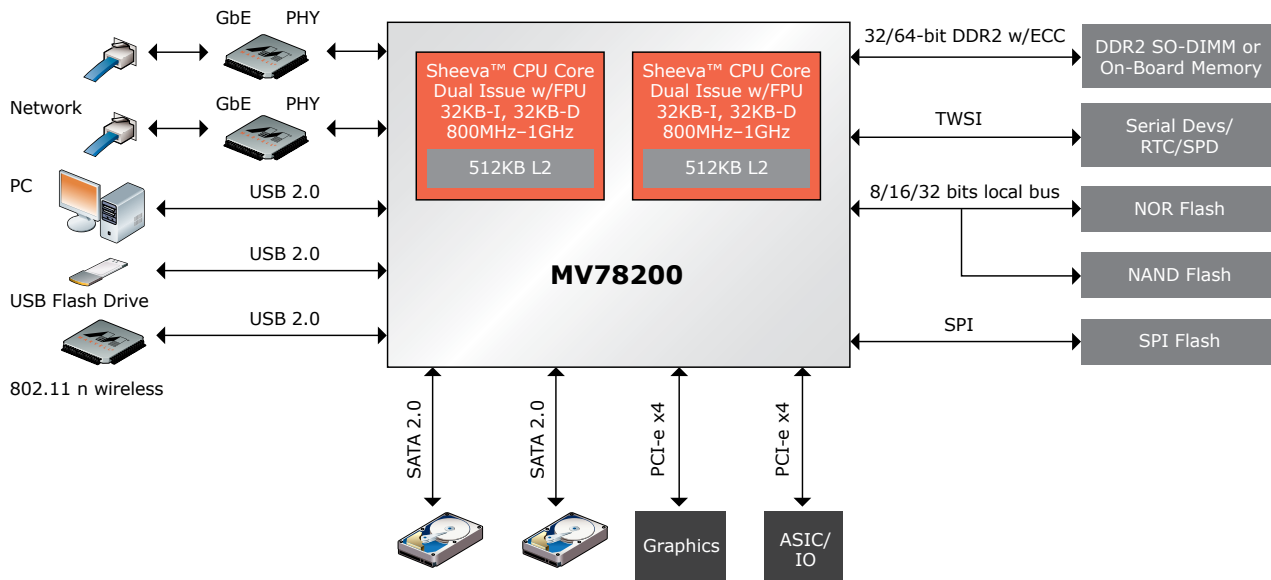

Fig 2. Marvell MV78200 — Typical System Implementation

THE MARVELL ADVANTAGE: Marvell products come with complete reference designs which include board layout designs, software, manufacturing diagnostic tools, documentation, and other items to assist customers with product evaluation and production. Marvell’s worldwide field application engineers collaborate closely with end customers to develop and deliver new leading-edge products for quick time-to-market. Marvell utilizes world-leading semiconductor foundry and packaging services to reliably deliver high-volume and low-cost total solutions.

ABOUT MARVELL: Marvell is a leader in storage, communications, and consumer silicon solutions. Marvell’s diverse product portfolio includes switching, transceiver, communications controller, processors, wireless, power management, and storage solutions that power the entire communications infrastructure, including enterprise, metro, home, and digital entertainment applications. For more information, visit our web site at www.marvell.com.



Marvell Semiconductor, Inc.
5488 Marvell Lane
Santa Clara, CA 95054
Phone 408.222.2500
www.marvell.com

Copyright © 2009. Marvell International Ltd. All rights reserved. Marvell, Moving Forward Faster, the Marvell logo, Alaska, AnyVoltage, DSP Switcher, Fastwriter, Feroceon, Libertas, Link Street, PHYAdvantage, Prestera, TopDog, Virtual Cable Tester, Yukon, and ZJ are registered trademarks of Marvell or its affiliates. CarrierSpan, LinkCrypt, Powered by Marvell Green PFC, Qdeo, QuietVideo, Sheeva, TwinD, UniMac, and VCT are trademarks of Marvell or its affiliates. Other names and brands may be claimed as the property of others.