



## 4-Pin Microprocessor Power Supply Supervisors with Manual Reset



### FEATURES

- Precision monitoring of
  - +5.0 V ( $\pm 5\%$ ,  $\pm 10\%$ ,  $\pm 20\%$ ),
  - +3.3 V ( $\pm 5\%$ ,  $\pm 10\%$ ),
  - +3.0 V ( $\pm 10\%$ ) and
  - +2.5 V ( $\pm 5\%$ ) power supplies
- Manual reset input
- Offered in two output configurations:
  - CAT811: Active LOW reset
  - CAT812: Active HIGH reset
- Direct replacements for the MAX811 and MAX812 in applications operating over the industrial temperature range
- Reset valid down to  $V_{CC} = 1.0V$
- 6 $\mu A$  power supply current
- Power supply transient immunity
- Available in SOT-143 packages with Sn or NiPdAu Green Lead finishes.
- Industrial temperature range:  $-40^{\circ}C$  to  $+85^{\circ}C$

### APPLICATION

- Computers, Servers, Laptops
- Cable modems
- Wireless communications
- Embedded control systems
- White goods
- Power meters
- Intelligent instruments
- PDAs and handheld equipment

### THRESHOLD SUFFIX SELECTOR DESCRIPTION

Nominal Threshold Voltage	Threshold Suffix Designation
4.63V	L
4.38V	M
4.00V	J
3.08V	T
2.93V	S
2.63V	R
2.32V	Z

### DESCRIPTION

The CAT811 and CAT812 are microprocessor supervisory circuits that monitor power supplies. The CAT811 and CAT812 are direct replacements for the MAX811 and MAX812 in applications operating over the industrial temperature range; both have a manual reset input.

These devices generate a reset signal, which is asserted while the power supply voltage is below a preset threshold level and for at least 140ms after the power supply level has risen above that level. The underlying floating gate technology, AE<sup>2</sup>(TM) used by Catalyst Semiconductor, makes it possible to offer any custom reset threshold value. Seven industry standard threshold levels are offered to support +5.0V, +3.3V, +3.0V and +2.5V systems.

The CAT811 features a RESET push-pull output (active LOW) and the CAT812 features a RESET push-pull output (active HIGH).

Fast transients on the power supply are ignored and the output is guaranteed to be in the correct state at  $V_{CC}$  levels as low as 1.0 V.

The CAT811/812 are fully specified over the industrial temperature range ( $-40^{\circ}C$  to  $85^{\circ}C$ ) and are available in a compact 4-pin SOT-143 package.

For Ordering Information details, see page 10.

### PIN CONFIGURATION

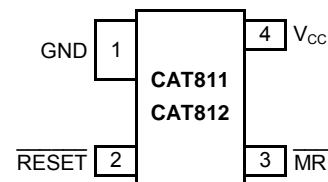

**PIN DESCRIPTION**

Pin Number		Name	Description
CAT811	CAT812		
1	1	GND	Ground
2	—	$\overline{\text{RESET}}$	Active LOW reset. $\overline{\text{RESET}}$ is asserted if $V_{CC}$ falls below the reset threshold and remains low for at least 140ms after $V_{CC}$ rises above the reset threshold.
—	2	RESET	Active HIGH reset. RESET is asserted if $V_{CC}$ falls below the reset threshold and remains high for at least 140ms after $V_{CC}$ rises above the reset threshold.
3	3	$\overline{\text{MR}}$	Manual Reset Input. A logic LOW on $\overline{\text{MR}}$ asserts $\overline{\text{RESET}}$ . RESET remains active as long as $\overline{\text{MR}}$ is LOW and for 140ms after $\overline{\text{MR}}$ returns HIGH. The active low input has an internal 20k $\Omega$ pull-up resistor. The input should be left open if not used.
4	4	$V_{CC}$	Power supply voltage that is monitored.

**BLOCK DIAGRAM**

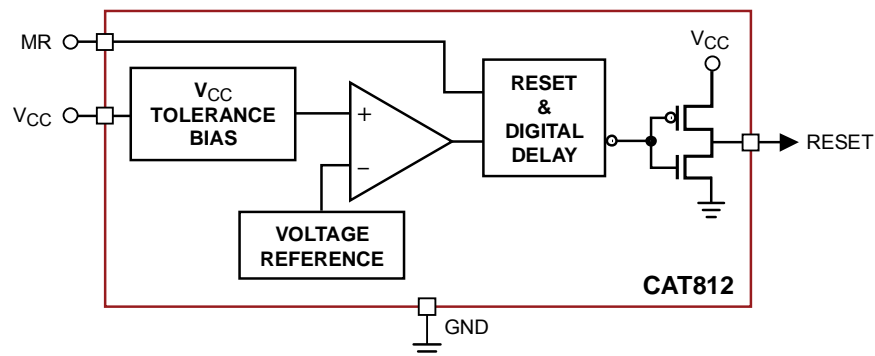
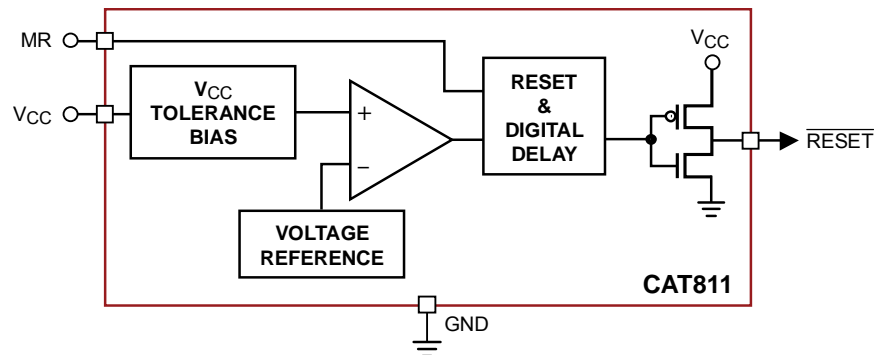

**ABSOLUTE MAXIMUM RATINGS<sup>(1)</sup>**

Parameters	Ratings	Units
Any pin with respect to ground	-0.3 to + 6.0	V
Input Current, $V_{CC}$	20	mA
Output Current RESET, $\overline{RESET}$	20	mA
Rate of Raise, $V_{CC}$	100	V/ $\mu$ s
Continuous Power Dissipations Derate 4mW/ $^{\circ}$ C above +70 $^{\circ}$ C (SOT-143)	320	mW
Storage Temperature	-65 to +105	$^{\circ}$ C
Operating Ambient Temperature	-40 to +85	$^{\circ}$ C
Lead Soldering (10 seconds)	+300	$^{\circ}$ C

**ELECTRICAL OPERATING CHARACTERISTICS**

$V_{CC}$  = Full range,  $T_A$  = -40 $^{\circ}$ C to +85 $^{\circ}$ C unless otherwise noted. Typical values at  $T_A$  = +25 $^{\circ}$ C and  $V_{CC}$  = 5V for the L/M/J versions,  $V_{CC}$  = 3.3V for the T/S versions,  $V_{CC}$  = 3V for the R version and  $V_{CC}$  = 2.5V for the Z version.

Parameter	Symbol	Conditions	Min	Typ	Max	Units	
$V_{CC}$ Range		$T_A$ = 0 $^{\circ}$ C to +70 $^{\circ}$ C	1.0		5.5	V	
		$T_A$ = -40 $^{\circ}$ C to +85 $^{\circ}$ C	1.2		5.5		
Supply Current	$I_{CC}$	$T_A$ = -40 $^{\circ}$ C to +85 $^{\circ}$ C	$V_{CC}$ < 5.5V, J/L/M		8	20	$\mu$ A
			$V_{CC}$ < 3.6V, R/S/T/Z		6	15	
Reset Threshold Voltage	$V_{TH}$	L Threshold	$T_A$ = +25 $^{\circ}$ C	4.56	4.63	4.70	V
			$T_A$ = -40 $^{\circ}$ C to +85 $^{\circ}$ C	4.50		4.75	
		M Threshold	$T_A$ = +25 $^{\circ}$ C	4.31	4.38	4.45	
			$T_A$ = -40 $^{\circ}$ C to +85 $^{\circ}$ C	4.25		4.50	
		J Threshold	$T_A$ = +25 $^{\circ}$ C	3.93	4.00	4.06	
			$T_A$ = -40 $^{\circ}$ C to +85 $^{\circ}$ C	3.89		4.10	
		T Threshold	$T_A$ = +25 $^{\circ}$ C	3.04	3.08	3.11	
			$T_A$ = -40 $^{\circ}$ C to +85 $^{\circ}$ C	3.00		3.15	
		S Threshold	$T_A$ = +25 $^{\circ}$ C	2.89	2.93	2.96	
			$T_A$ = -40 $^{\circ}$ C to +85 $^{\circ}$ C	2.85		3.00	
		R Threshold	$T_A$ = +25 $^{\circ}$ C	2.59	2.63	2.66	
			$T_A$ = -40 $^{\circ}$ C to +85 $^{\circ}$ C	2.55		2.70	
		Z Threshold	$T_A$ = +25 $^{\circ}$ C	2.28	2.32	2.35	
			$T_A$ = -40 $^{\circ}$ C to +85 $^{\circ}$ C	2.25		2.38	

**Notes:**

- (1) Stresses above those listed under "Absolute Maximum Ratings" may cause permanent damage to the device. These are stress ratings only, and functional operation of the device at these or any other conditions outside of those listed in the operational sections of this specification is not implied. Exposure to any absolute maximum rating for extended periods may affect device performance and reliability.

**ELECTRICAL OPERATING CHARACTERISTICS (continued)**

V<sub>CC</sub> = Full range, T<sub>A</sub> = -40°C to +85°C unless otherwise noted. Typical values at T<sub>A</sub> = +25°C and V<sub>CC</sub> = 5V for the L/M/J versions, V<sub>CC</sub> = 3.3V for the T/S versions, V<sub>CC</sub> = 3V for the R version and V<sub>CC</sub> = 2.5V for the Z version.

Parameter	Symbol	Conditions	Min	Typ <sup>(1)</sup>	Max	Units
Reset Threshold Tempco				30		ppm/°C
V <sub>CC</sub> to Reset Delay <sup>(2)</sup>		V <sub>CC</sub> = V <sub>TH</sub> to (V <sub>TH</sub> - 100mV)		20		µs
Reset Active Timeout Period		T <sub>A</sub> = -40°C to +85°C	140	240	400	ms
RESET Output Voltage Low (Push-pull, active LOW, CAT811)	V <sub>OL</sub>	V <sub>CC</sub> = V <sub>TH min</sub> , I <sub>SINK</sub> = 1.2mA CAT811R/S/T/Z			0.3	V
		V <sub>CC</sub> = V <sub>TH min</sub> , I <sub>SINK</sub> = 3.2mA CAT811J/L/M			0.4	
		V <sub>CC</sub> > 1.0V, I <sub>SINK</sub> = 50µA			0.3	
RESET Output Voltage High (Push-pull, active LOW, CAT811)	V <sub>OH</sub>	V <sub>CC</sub> = V <sub>TH max</sub> , I <sub>SOURCE</sub> = 500µA CAT811R/S/T/Z	0.8V <sub>CC</sub>			V
		V <sub>CC</sub> = V <sub>TH max</sub> , I <sub>SOURCE</sub> = 800µA CAT811J/L/M	V <sub>CC</sub> - 1.5			
RESET Output Voltage Low (Push-pull, active HIGH, CAT812)	V <sub>OL</sub>	V <sub>CC</sub> > V <sub>TH max</sub> , I <sub>SINK</sub> = 1.2mA CAT812R/S/T/Z			0.3	V
		V <sub>CC</sub> > V <sub>TH max</sub> , I <sub>SINK</sub> = 3.2mA CAT812J/L/M			0.4	
RESET Output Voltage High (Push-pull active HIGH, CAT812)	V <sub>OH</sub>	1.8 V < V <sub>CC</sub> ≤ V <sub>TH min</sub> , I <sub>SOURCE</sub> = 150µA	0.8V <sub>CC</sub>			V
MR Minimum Pulse Width	t <sub>MR</sub>		10			µs
MR Glitch Immunity		Note 3		100		ns
MR to RESET Propagation Delay	t <sub>MD</sub>	Note 2		0.5		µs
MR Input Threshold	V <sub>IH</sub>	V <sub>CC</sub> > V <sub>TH (MAX)</sub> , CAT811/812L/M/J	2.3V			
	V <sub>IL</sub>				0.8	V
	V <sub>IH</sub>	V <sub>CC</sub> > V <sub>IH (MAX)</sub> , CAT811/812R/S/T/Z	0.7V <sub>CC</sub>			
	V <sub>IL</sub>				0.25V <sub>CC</sub>	
MR Pull-up Resistance			10	20	75	kΩ

**Notes:**

- (1) Production testing done at T<sub>A</sub> = +25°C; limits over temperature guaranteed by design only.
- (2) RESET output for the CAT811; RESET output for the CAT812
- (3) Glitches of 100ns or less typically will not generate a reset pulse

### TYPICAL OPERATING CHARACTERISTICS

$V_{CC}$  = Full range,  $T_A$  =  $-40^{\circ}\text{C}$  to  $+85^{\circ}\text{C}$  unless otherwise noted. Typical values at  $T_A = +25^{\circ}\text{C}$  and  $V_{CC} = 5\text{V}$  for the L/M/J versions,  $V_{CC} = 3.3\text{V}$  for the T/S versions,  $V_{CC} = 3\text{V}$  for the R version and  $V_{CC} = 2.5\text{V}$  for the Z version.

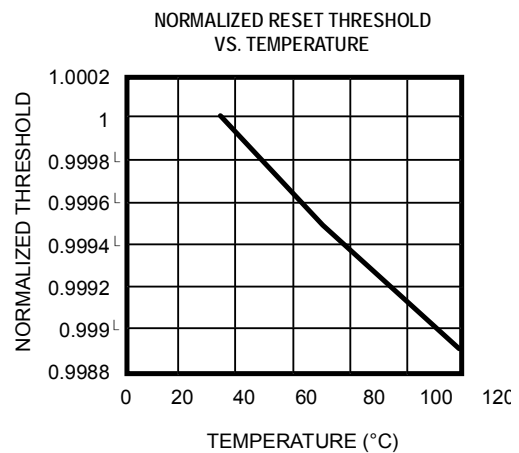
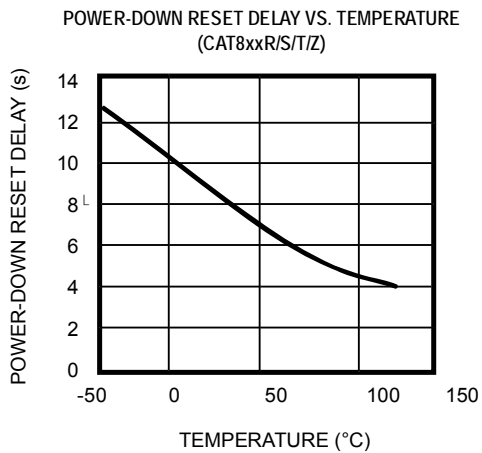
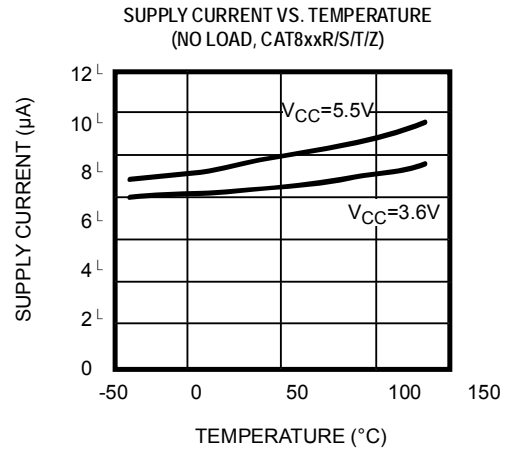
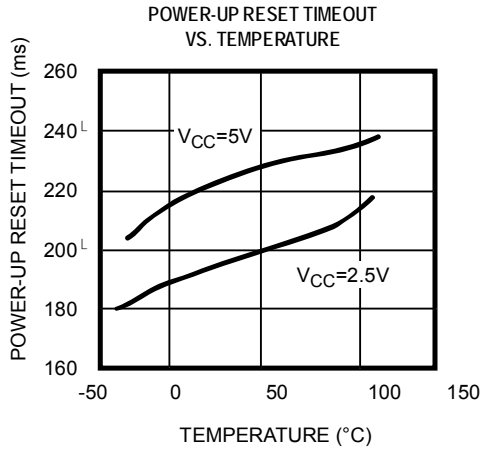

## DETAILED DESCRIPTION

### RESET TIMING

The reset signal is asserted LOW for the CAT811 and HIGH for the CAT812 when the power supply voltage falls below the threshold trip voltage and remains asserted for at least 140ms after the power supply voltage has risen above the threshold.

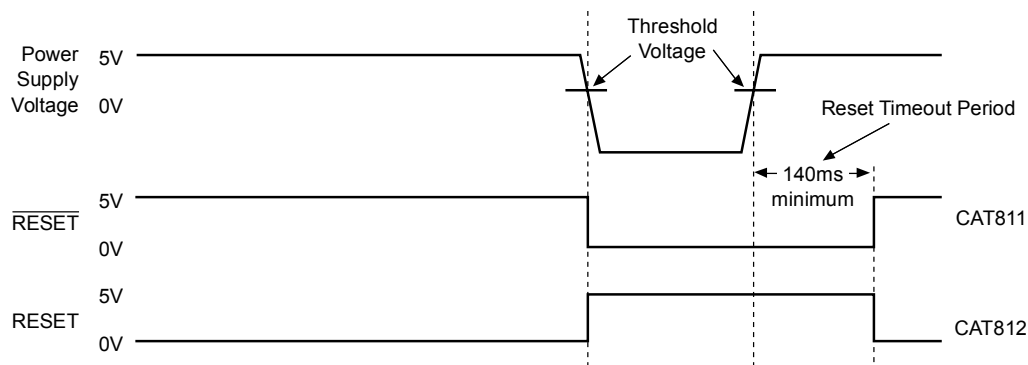

Figure 1. Reset Timing Diagram

### V<sub>CC</sub> TRANSIENT RESPONSE

The CAT811/812 protect  $\mu$ Ps against brownout failure. Short duration transients of 4 $\mu$ s or less and 100mV amplitude typically do not cause a false RESET.

Figure 2 shows the maximum pulse duration of negative-going V<sub>CC</sub> transients that do not cause a reset condition.

As the amplitude of the transient goes further below the threshold (increasing  $V_{TH} - V_{CC}$ ), the maximum pulse duration decreases. In this test, the V<sub>CC</sub> starts from an initial voltage of 0.5V above the threshold and drops below it by the amplitude of the overdrive voltage ( $V_{TH} - V_{CC}$ ).

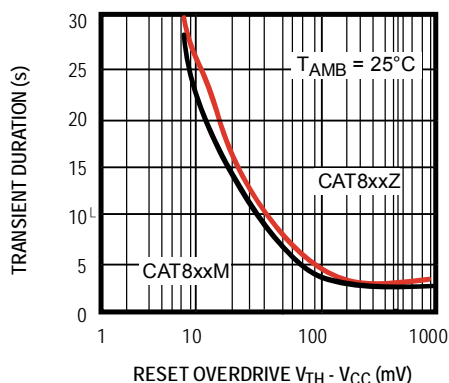
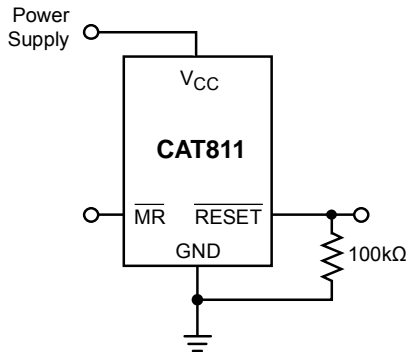

Figure 2. Maximum Transient Duration without Causing a Reset Pulse vs. Reset Comparator Overdrive

**VALID RESET WITH  $V_{CC}$  UNDER 1.0V**

To ensure that the CAT811  $\overline{\text{RESET}}$  pin is in a known state when  $V_{CC}$  is under 1.0V, a 100k $\Omega$  pull-down resistor between  $\overline{\text{RESET}}$  pin and GND is recommended; the value is not critical. For the CAT812, a pull-up resistor from  $\overline{\text{RESET}}$  pin to  $V_{CC}$  is needed.



**Figure 3. RESET Valid with  $V_{CC}$  under 1.0V**

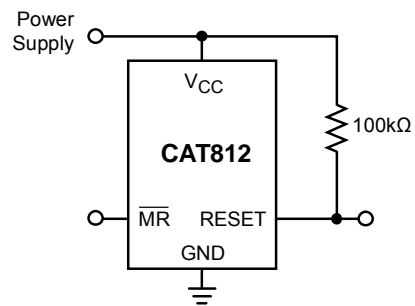

**Figure 4. RESET Valid with  $V_{CC}$  under 1.1V**

**BI-DIRECTIONAL RESET PIN INTERFACING**

The CAT811/812 can interface with  $\mu\text{P}/\mu\text{C}$  bi-directional reset pins by connecting a 4.7k $\Omega$  resistor in series with the CAT811/812 reset output and the  $\mu\text{P}/\mu\text{C}$  bi-directional reset pin.

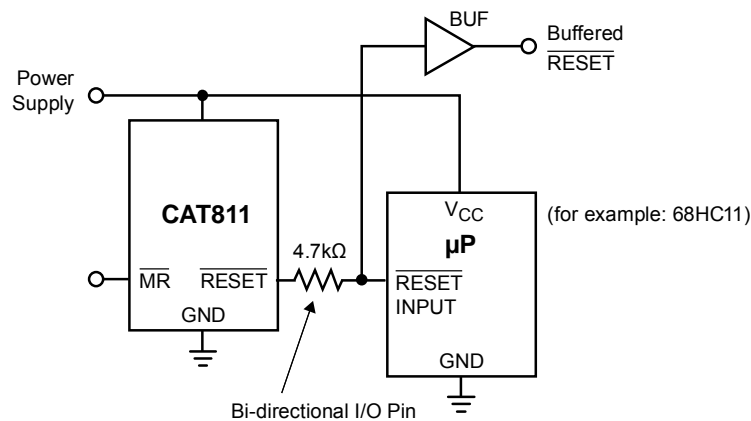

**Figure 5. Bi-directional Reset Pin Interfacing**

**OTHER SUPERVISORY PRODUCTS**

Function	CAT1161/3	CAT1162	CAT809	CAT810	CAT811	CAT812
With 16k Bit Serial EEPROM Memory	✓	✓				
Watchdog Timer	✓					
Manual Reset Input	✓	✓			✓	✓
Active Low Reset			✓		✓	
Active High Reset				✓		✓
Dual Polarity Reset Outputs	✓	✓				
Package	8-pin DIP and SOIC	8-pin DIP and SOIC	3-pin SOT-23 and SC70	3-pin SOT-23 and SC70	4-pin SOT-143	4-pin SOT-143



PACKAGE OUTLINE DRAWING

SOT-143 4-Lead (TB)

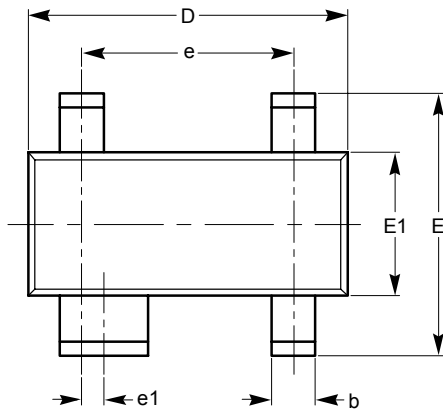

TOP VIEW

SYMBOL	MIN	NOM	MAX
A	0.80		1.22
A1	0.05		0.15
A2	0.75	0.90	1.07
b	0.30		0.50
b2	0.76		0.89
c	0.08		0.20
D	2.80	2.90	3.04
E	2.10		2.64
E1	1.20	1.30	1.40
e	1.92 BSC		
e1	0.20 BSC		
L	0.40	0.50	0.60
L1	0.54 REF		
L2		0.25	
$\theta$	0°		8°

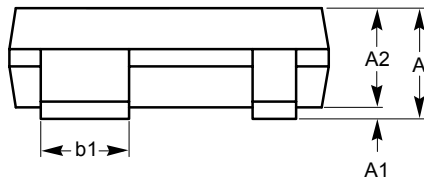

SIDE VIEW

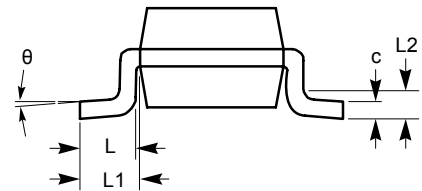

END VIEW

Notes:

- (1) All dimensions are in millimeters. Angles in degrees.
- (2) Complies with JEDEC standard TO-253.

**EXAMPLE OF ORDERING INFORMATION**

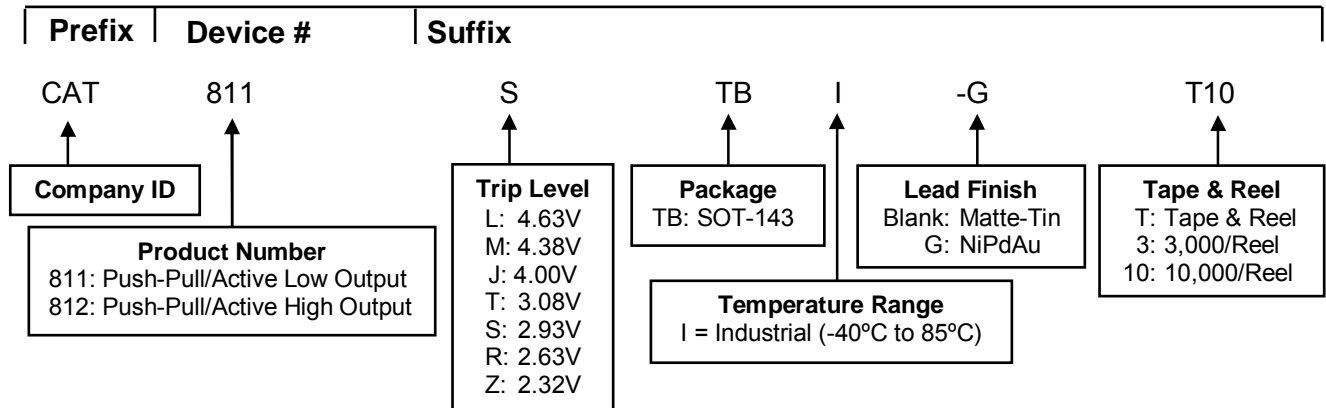

**Notes:**

- (1) All packages are RoHS-compliant (Lead-free, Halogen-free).
- (2) The standard lead finish is NiPdAu. Contact factory for other package availability.
- (3) This device used in the above example is a CAT811STBI-GT10 (SOT-143 4-Lead, Push-Pull/Active Low Output, trip level of 2.85V to 3.00V, NiPdAu, Tape & Reel, 10,000/Reel)
- (4) For additional package and temperature options, please contact your nearest ON Semiconductor Sales office.

## REVISION HISTORY

Date	Rev.	Description
22-Oct-03	L	Updated Ordering Information
22-Dec-03	M	Updated Features Replaced power-up reset timeout vs. temperature graph with updated one Replaced $V_{CC}$ Transient Response graph with updated one
22-Mar-04	N	General data sheet updates
25-Mar-04	O	Updated Electrical Characteristics (Reset Active Timeout Period Max)
25-Mar-04	P	Corrected Pin Configure diagram
28-Sept-04	Q	Minor changes
28-Dec-05	R	Updated Features Updated Ordering Information Updated Top Marking
18-Apr-08	S	Add "MD-" to document number Add Block Diagrams Updated Package Outline Drawing Update Example of Ordering Information
5-Nov-08	T	Change logo and fine print to ON Semiconductor
19-May-10	U	Update Electrical Operating Characteristics

ON Semiconductor and  are registered trademarks of Semiconductor Components Industries, LLC (SCILLC). SCILLC reserves the right to make changes without further notice to any products herein. SCILLC makes no warranty, representation or guarantee regarding the suitability of its products for any particular purpose, nor does SCILLC assume any liability arising out of the application or use of any product or circuit, and specifically disclaims any and all liability, including without limitation special, consequential or incidental damages. "Typical" parameters which may be provided in SCILLC data sheets and/or specifications can and do vary in different applications and actual performance may vary over time. All operating parameters, including "Typicals" must be validated for each customer application by customer's technical experts. SCILLC does not convey any license under its patent rights nor the rights of others. SCILLC products are not designed, intended, or authorized for use as components in systems intended for surgical implant into the body, or other applications intended to support or sustain life, or for any other application in which the failure of the SCILLC product could create a situation where personal injury or death may occur. Should Buyer purchase or use SCILLC products for any such unintended or unauthorized application, Buyer shall indemnify and hold SCILLC and its officers, employees, subsidiaries, affiliates, and distributors harmless against all claims, costs, damages, and expenses, and reasonable attorney fees arising out of, directly or indirectly, any claim of personal injury or death associated with such unintended or unauthorized use, even if such claim alleges that SCILLC was negligent regarding the design or manufacture of the part. SCILLC is an Equal Opportunity/Affirmative Action Employer. This literature is subject to all applicable copyright laws and is not for resale in any manner.

### PUBLICATION ORDERING INFORMATION

#### LITERATURE FULFILLMENT:

Literature Distribution Center for ON Semiconductor  
P. O. Box 5163, Denver, Colorado 80217 USA  
Phone: 303-675-2175 or 800-344-3860 Toll Free USA/Canada  
Fax: 303-675-2176 or 800-344-3867 Toll Free USA/Canada  
Email: [orderlit@onsemi.com](mailto:orderlit@onsemi.com)

N. American Technical Support: 800-282-9855 Toll Free  
USA/Canada  
Europe, Middle East and Africa Technical Support:  
Phone: 421 33 790 2910  
Japan Customer Focus Center:  
Phone: 81-3-5773-3850

ON Semiconductor Website: [www.onsemi.com](http://www.onsemi.com)

Order Literature: <http://www.onsemi.com/orderlit>

For additional information, please contact your local Sales Representative