

Series 140-107 Jumbo Junction Box

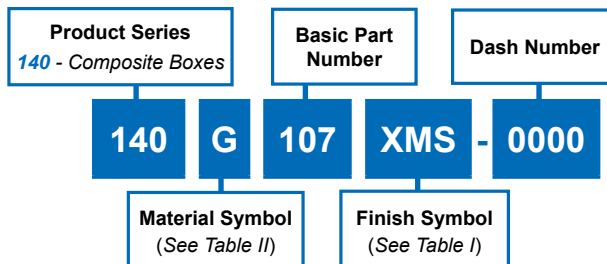
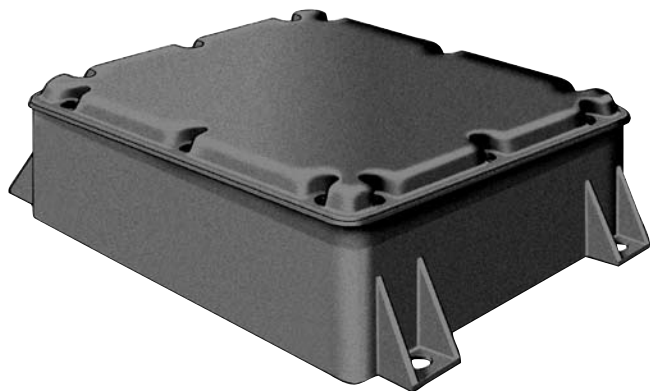

Jumbo Series 140-107 CostSaver Composite Junction Box

TABLE II: MATERIAL COLOR & FINISH OPTIONS

Sym	Material & Color	Finish Options
B	Thermoplastic / Black	XO and XMS
G	Thermoplastic / Grey	XO and XMS
-	Thermoplastic / NA	XM, XW and XZN

TABLE I: FINISHES

Symbol	Finish Description
XO	No Plating (Non-Conductive Finish)
XMS	Internal Surfaces - Electroless Nickel External Surfaces - See Table II
XM	All Surfaces - Electroless Nickel
XW	All Surfaces - Cadmium Olive Drab over Electroless Nickel
XZN	All Surfaces - Zinc Nickel/Black
XMT	2000 Hour Corrosion Resistant Ni-PTFE, Nickel-Fluorocarbon Polymer. 1000 Hour Grey™

TABLE III: KEY DIMENSIONS

Box Series Number	External Dimensions	Internal Dimensions (with Aluminum Mounting Plate Installed, if applicable)
Jumbo 140-107	9.13 (232) x 11.63 (295) x 3.88 (98.5)	8.0 (203) x 10.50 (267) x 3.0 (76)

NOTES

- Use Dash Number 0000 for Basic Box with No Additional Options Beyond Your Specified Finish. 0000 Basic Box Includes #6-32 UNC Fasteners.
- Box Series Numbers are for reference only. Please complete the worksheet on E-14 and call the factory for part number assignment for your specific box configuration.
- Metric dimensions (mm) are in parenthesis and for reference only

Series 140-107
Jumbo Junction Box



Composite
Junction
Boxes

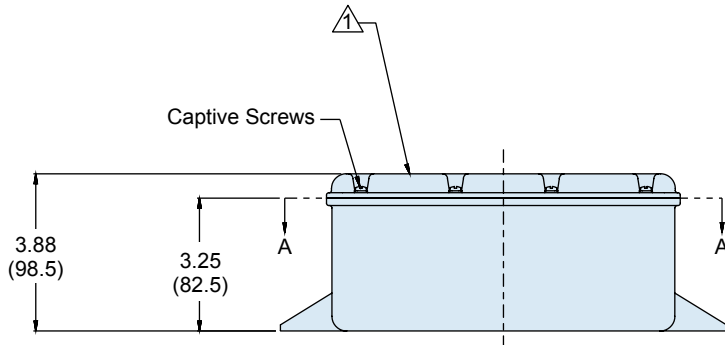
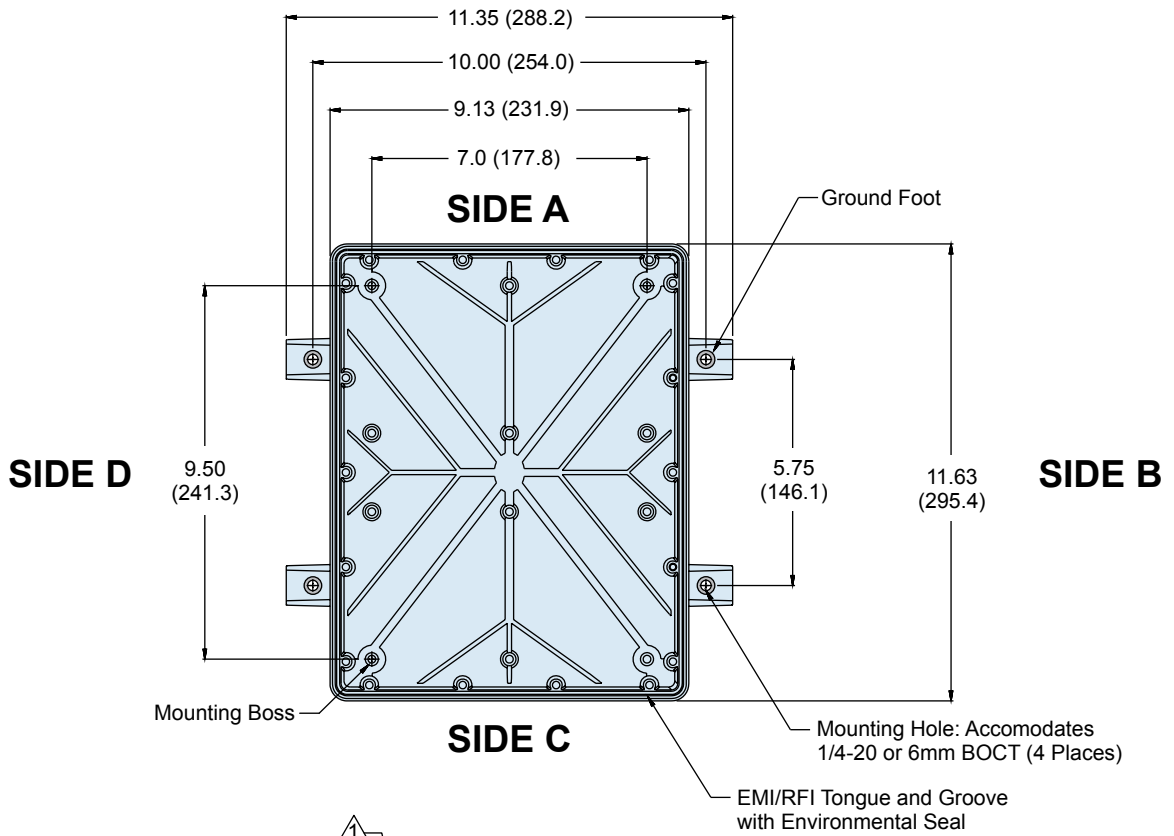

**SIDES
A and C**

**SIDES
B and D**

