

Linear Positive Tempco Thermistor Type LT73

ISO 9001:2000
CERTIFIED
TS-16949
CERTIFIED

1. General

- Anti-leaching nickel barrier terminations
- Twenty-five specifiable temperature characteristics
- SMD thin film resistor with thermo-perceptivity
- Marking: black four-digit on bronze body color

2. Dimensions

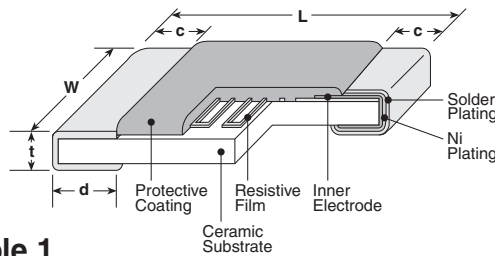

Table 1

Dimensions - inches (mm)					
Part	L	W	c	d	t
2A (0805)	0.079±0.008 (2.00±0.20)	0.049±0.008 (1.25±0.20)	0.016±0.008 (0.40±0.20)	0.012 ^{+0.008} _{-0.004} (0.30 ^{+0.20} _{-0.10})	0.020±0.004 (0.50±0.10)
2B (1206)	0.126±0.008 (3.20±0.20)	0.063±0.008 (1.60±0.20)	0.020±0.012 (0.50±0.30)	0.016 ^{+0.008} _{-0.004} (0.40 ^{+0.20} _{-0.10})	0.024±0.004 (0.60±0.10)

3. Type Designation

The type designation shall be in the following form:

New Type

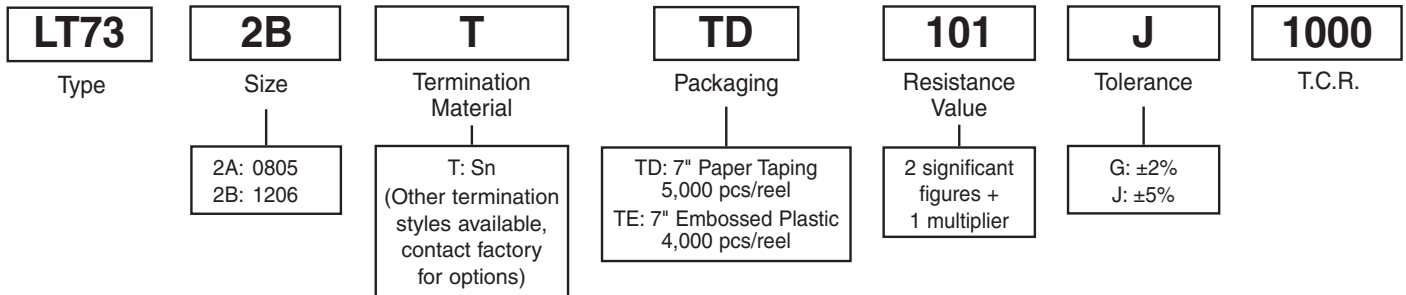

4. Standard Applications

Part Designation	Power Rating @ 70°C	Absolute Maximum Working Voltage	Absolute Maximum Overload Voltage	Operating Temp. Range	Resistance Range E-24*		Resistance Tolerance	T.C.R. (ppm/°C) Maximum**	T.C.R. Tolerance	
					LT732A	LT732B				
LT732A	100mW	50V	100V	-40°C to +125°C	2KΩ - 24KΩ	2KΩ - 51KΩ	G: ±2%	150, 250, 350, 450, 500	±100ppm/°C	
					1KΩ - 20KΩ	1KΩ - 43KΩ		600, 700, 800, 900		±150ppm/°C
					1KΩ - 13KΩ	1KΩ - 27KΩ		1000, 1200, 1400		
					510Ω - 4.7KΩ	1KΩ - 10KΩ		1600, 1800		
					510Ω - 4.7KΩ	510Ω - 9.1KΩ		2000, 2200, 2400		
510Ω - 3.0KΩ	510Ω - 6.2KΩ	J: ±5%	2600, 2800	±10%						
510Ω - 3.0KΩ	510Ω - 6.2KΩ		3000, 3300, 3600							
510Ω - 3.0KΩ	510Ω - 6.2KΩ		3900							
100Ω - 1KΩ	100Ω - 2KΩ		4200							
51Ω - 510Ω	51Ω - 510Ω		4500							

* See Appendix D for available decade values.

** T.C.R. is factory tested from 25°C to 75°C.

5. Environmental Applications

5.1 Derating Curve

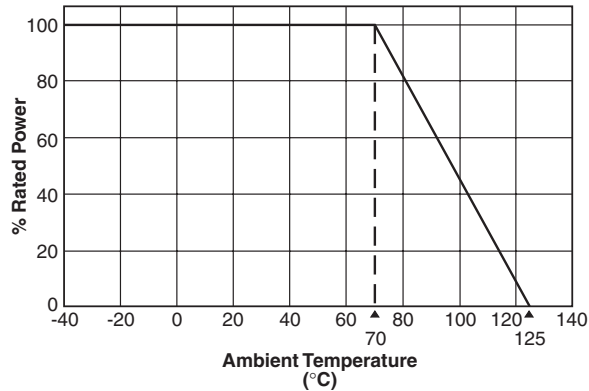

5.2 Temperature Characteristics

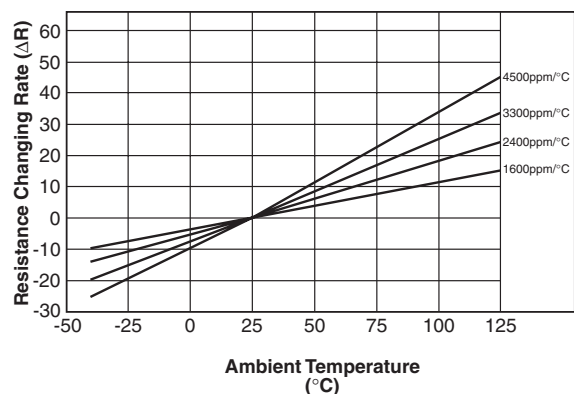
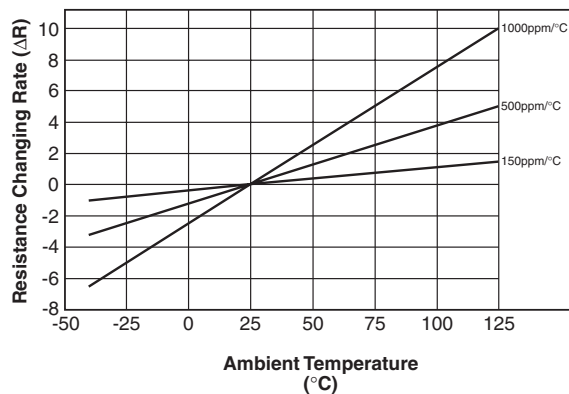

6. Approximate Expression for Resistance-Temperature Characteristics

T.C.R. (x10 ⁻⁶ /K)	C ₀	C ₁	C ₂
3000	0.934	0.00258	2.77 x 10 ⁻⁶
3300	0.927	0.00282	3.17 x 10 ⁻⁶
3600	0.921	0.00306	3.58 x 10 ⁻⁶
3900	0.915	0.00330	4.00 x 10 ⁻⁶
4200	0.909	0.00353	4.44 x 10 ⁻⁶
4500	0.903	0.00377	4.89 x 10 ⁻⁶

7. Performance Characteristics

Parameter	Maximum ΔR	Test Method
Thermal Shock	±1.0%	MIL-STD-202, Method 107, -55°C to +155°C, 5 cycles
Low Temperature Operation	±1.0%	MIL-R-55342 π 4.7.4, 1 Hour @ -55°C followed by 45 minutes of RCWV*
High Temperature Exposure	±1.0%	MIL-R-55342 π 4.7.6, 100 hours @ 125°C
Short Time Overload	±1.0%	MIL-R-55342 π 4.7.5, 2.5 x RCWV for 5 seconds
Resistance to Solder Heat	±1.0%	MIL-R-55342 π 4.7.7, 260°C for 10 seconds
Terminal Strength-Bend	±1.0%	2mm min. deflection in either direction for 10 seconds
Moisture Resistance	±3.0%	MIL-STD-202, Method 103, 40°C, 90 - 95% RH, 1000 hours
Life	±3.0%	MIL-STD-202, Method 108, 70°C, 1000 hours @ RCWV, 1.5 hr ON, 0.5 hr OFF
Temperature Cycling	±1.0%	30 minutes @ -55°C, 15 minutes @ +25°C, 30 minutes @ +125°C, 15 minutes @ +25°C, 5 cycles

* RCWV = Rated Continuous Working Voltage

8. Dimensions

8.1 Carrier Tape

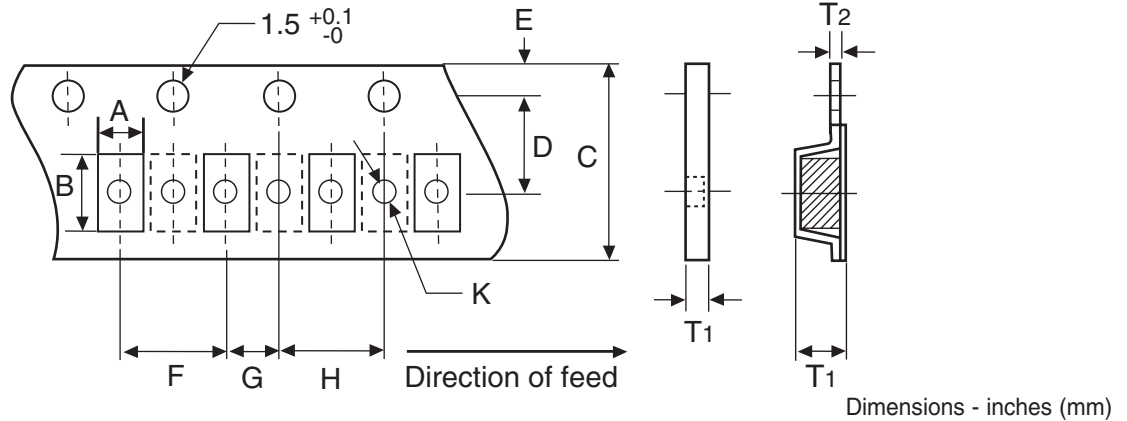

Tape	B	C	D	E	F	G	H
2A	0.094±0.002 (2.4±0.1)	0.315±0.008 (8.0±0.2)	0.138±0.002 (3.5±0.05)	0.069±0.004 (1.75±0.1)	0.157±0.004 (4.0±0.1)	0.079±0.002 (2.0±0.05)	0.157±0.004 (4.0±0.1)
2B	0.138±0.002 (3.5±0.1)	0.315±0.008 (8.0±0.2)	0.138±0.002 (3.5±0.05)	0.069±0.004 (1.75±0.1)	0.157±0.004 (4.0±0.1)	0.079±0.002 (2.0±0.05)	0.157±0.004 (4.0±0.1)

Tape	A	K	T1	T2
2A (TD)	0.065±0.008 (1.65±0.2)	—	0.030 (0.75 ^{+0.2} ₋₀)	—
2A (TE)	0.063±0.006 (1.60±0.15)	0.047 (1.2 Max.)	0.030 (0.75 ^{+0.2} ₋₀)	0.010±0.002 (0.25±0.05)
2B (TD)	0.079±0.008 (2.0±0.2)	—	0.035±0.004 (0.90±0.1)	—
2B (TE)	0.075±0.008 (1.9±0.2)	0.047 (1.2 Max.)	0.039±0.004 (1.0±0.1)	0.010±0.002 (0.25±0.05)

8.2 Reel

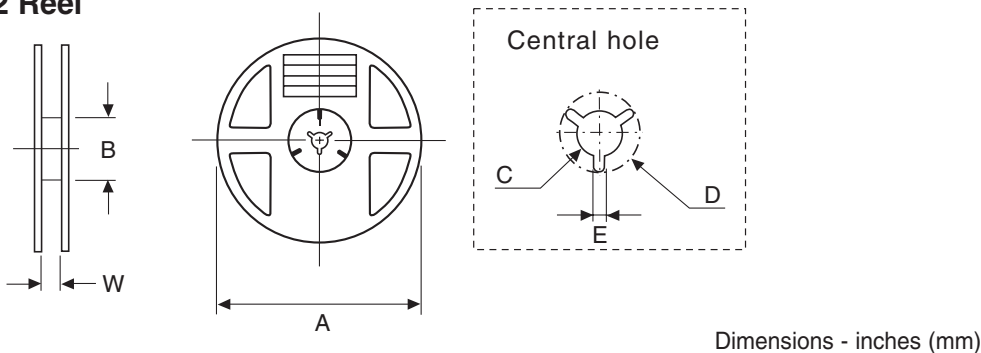

Tape	A	B	W	C	D	E
TD	7.008±0.079 (178±2.0)	2.362±0.079 (60±2.0)	0.394±0.047 (10.0±1.2)	0.512±0.020 (13±0.5)	0.827±0.031 (21±0.8)	0.079±0.020 (2.0±0.5)
TE	7.008±0.079 (178±2.0)	2.362±0.079 (60±2.0)	0.394±0.047 (10.0±1.2)	0.512±0.020 (13±0.5)	0.827±0.031 (21±0.8)	0.079±0.020 (2.0±0.5)