



Preliminary Specification MBRS30H45CT

30.0 AMPS. Surface Mount Schottky Barrier Rectifiers D²PAK

Features

- ✧ Plastic material used carries Underwriters Laboratory Classifications 94V-0
- ✧ Metal silicon junction, majority carrier conduction
- ✧ Low power loss, high efficiency
- ✧ High current capability · low forward voltage drop
- ✧ High Surge capability
- ✧ For use in low voltage, high frequency inverters, free wheeling, and polarity protection applications.
- ✧ Guarding for over voltage protection
- ✧ High temperature soldering guaranteed: 260°C/10 seconds at terminals.

Mechanical Data

- ✧ Cases: JEDEC D²PAK molded plastic
- ✧ Terminals: Leads solderable per MIL-STD-750, Method 2026
- ✧ Polarity: As marked
- ✧ Mounting position: Any
- ✧ Mounting torque: 5 in. - lbs. max
- ✧ Weight: 1.41 grams

Maximum Ratings and Electrical Characteristics

Rating at 25°C ambient temperature unless otherwise specified.

Single phase, half wave, 60 Hz, resistive or inductive load.

For capacitive load, derate current by 20%

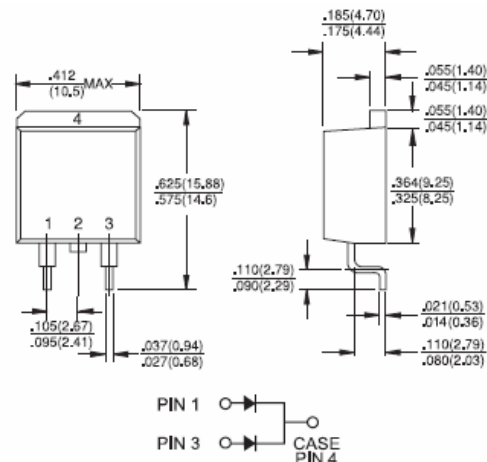

Dimensions in inches and (millimeters)
Marking Diagram



MBRS30H45CT = Specific Device Code
G = Green Compound
Y = Year
WW = Work Week

Type Number	Symbol	MBRS30H45CT	Units
Maximum Recurrent Peak Reverse Voltage	V_{RRM}	45	V
Maximum RMS Voltage	V_{RMS}	31	V
Maximum DC Blocking Voltage	V_{DC}	45	V
Maximum Average Forward Rectified Current @ $T_c = 155^\circ\text{C}$ (Total Device)	$I_{(AV)}$	30.0	A
Peak Forward Surge Current, 8.3 ms Single Half Sine-wave Superimposed on Rated Load (JEDEC method)	I_{FSM}	220.0	A
Peak Repetitive Reverse Surge Current(Note1)	I_{RRM}	1.0	A
Maximum Instantaneous Forward Voltage at (Note2) IF = 15A, Tc=25°C IF = 15A, Tc=125°C IF = 30A, Tc=25°C IF = 30A, Tc=125°C	V_F	0.62 0.57 0.82 0.72	V
Maximum DC Reverse Current @ $T_c=25^\circ\text{C}$ at Rated DC Blocking Voltage @ $T_c=125^\circ\text{C}$	I_R	0.2 15.0	mA
Voltage Rate of Change (Rated V_R)	dv/dt	10,000	V/ μs
Maximum Thermal Resistance Per Leg (Note 3)	$R_{\theta JC}$	1.5	$^\circ\text{C}/\text{W}$
Operating Temperature Range	T_J	-65 to +175	$^\circ\text{C}$
Storage Temperature Range	T_{STG}	-65 to +175	$^\circ\text{C}$

Note : 1. 2.0us Pulse Width, f=1.0 KHz

2. Pulse Test : 300us Pulse Width, 1% Duty cycle

3. Thermal Resistance from Junction to Case Per Leg

RATING AND CHARACTERISTIC CURVES (MBRS30H45CT)

FIG. 1- MAXIMUM FORWARD CURRENT DERATING CURVE

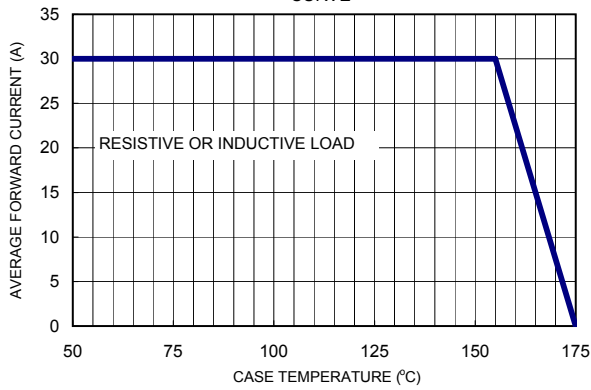

FIG. 2- MAXIMUM NON-REPETITIVE FORWARD SURGE CURRENT PER LEG

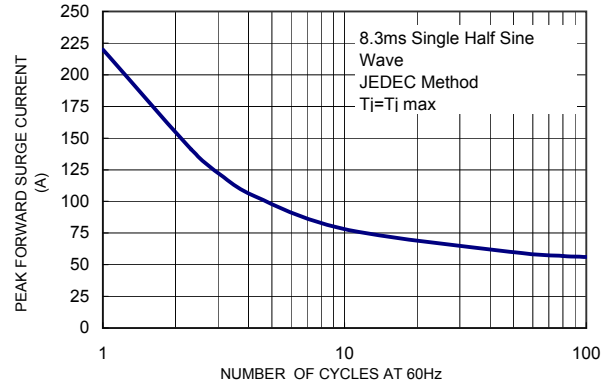

FIG. 3- TYPICAL INSTANTANEOUS FORWARD CHARACTERISTICS PER LEG

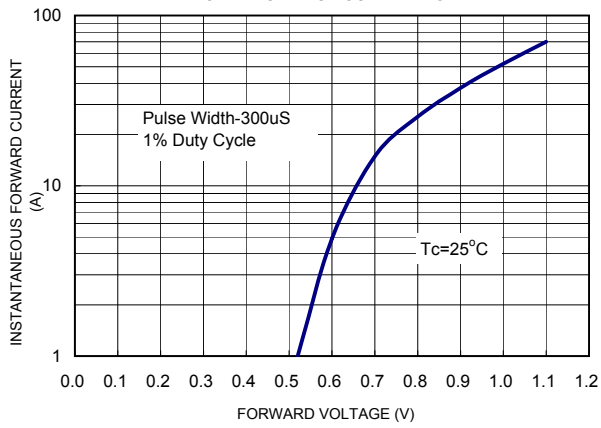

FIG 4 Typical Reverse Characteristics Per Leg

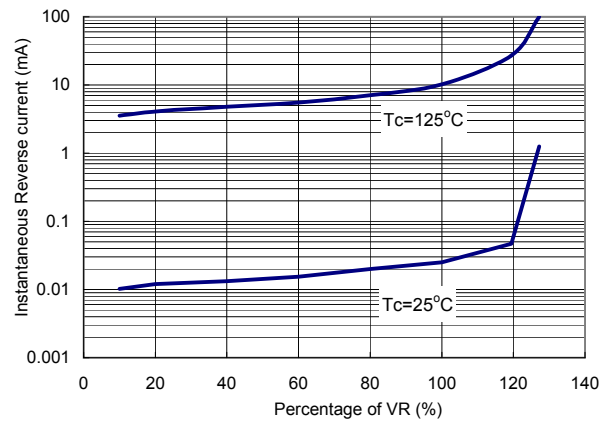

Fig. 5- TYPICAL JUNCTION CAPACITANCE PER LEG

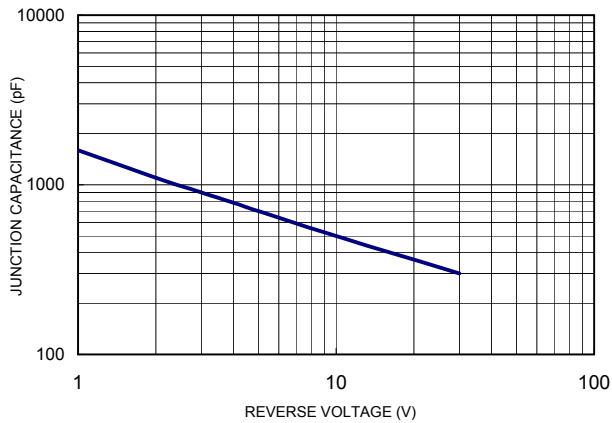

Fig. 6- TYPICAL TRANSIENT THERMAL IMPEDANCE PER LEG

