

SERIES: ACZ16

DESCRIPTION: mechanical incremental encoder

ELECTRICAL SPECIFICATIONS

parameter	conditions/description
output waveform	square wave
output signals	A, B phase
current consumption	0.5 mA
output phase difference	T1, T2, T3, T4 \geq 3.5 ms @ 60 rpm (see output waveform)
supply voltage	5 V dc max.
output resolution	12, 24 ppr
insulation resistance	50 V dc, 100 M Ω
withstand voltage	50 V ac

MECHANICAL SPECIFICATIONS

parameter	conditions/description	min	nom	max	units
shaft load	axial			7	kgf
rotational torque	with detent click	50		130	gf·cm
	without detent click	90		210	gf·cm
rotational life				100,000	cycles

ENVIRONMENTAL SPECIFICATIONS

parameter	conditions/description	min	nom	max	units
operating temperature		-10		65	$^{\circ}$ C
storage temperature		-40		75	$^{\circ}$ C
humidity		85			% RH
vibration	0.75 mm max. travel for 2 hours	10		55	Hz

PART NUMBER KEY

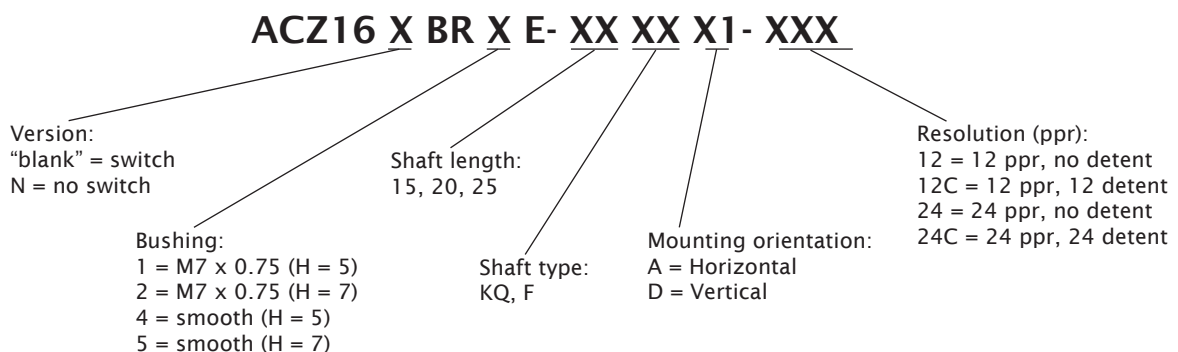

SERIES: ACZ16

DESCRIPTION: mechanical incremental encoder

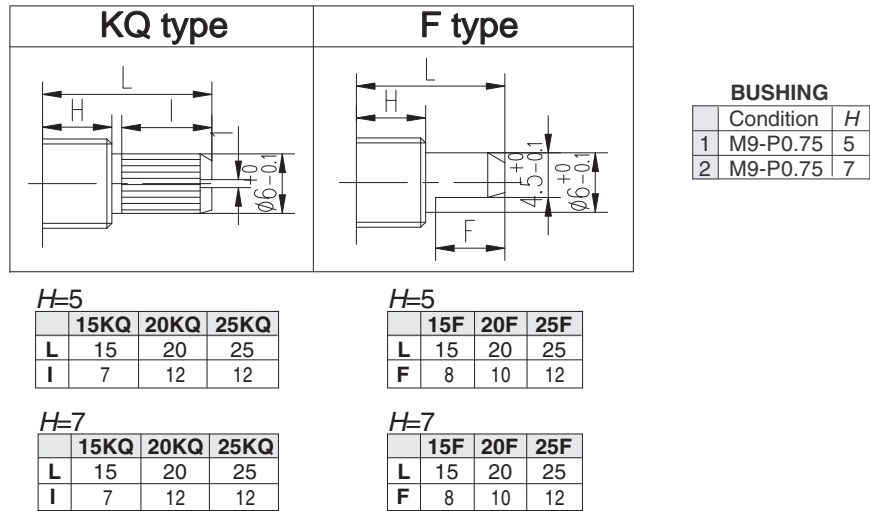
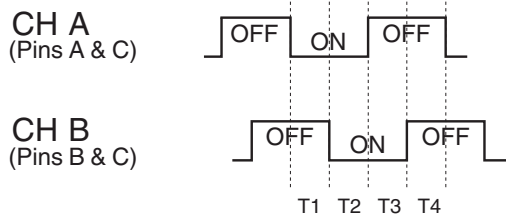
SHAFT OPTIONS

OUTPUT WAVEFORM

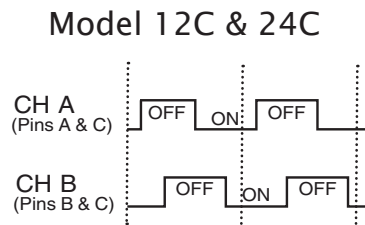
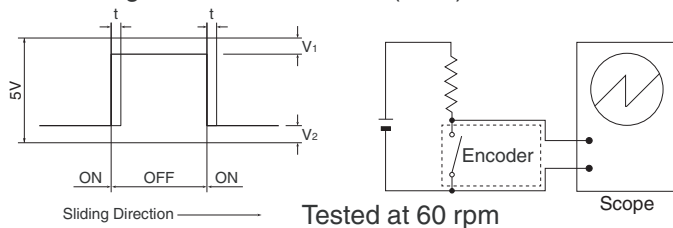
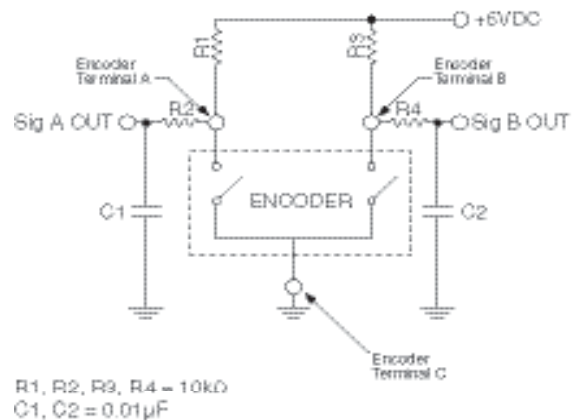
CW direction (@ 60 rpm)

DETENT POSITIONS

SLIDING NOISE
 $t = \text{Masking time to avoid chatter (5mS)}$ $V_1 = V_2 = 1V \text{ max.}$

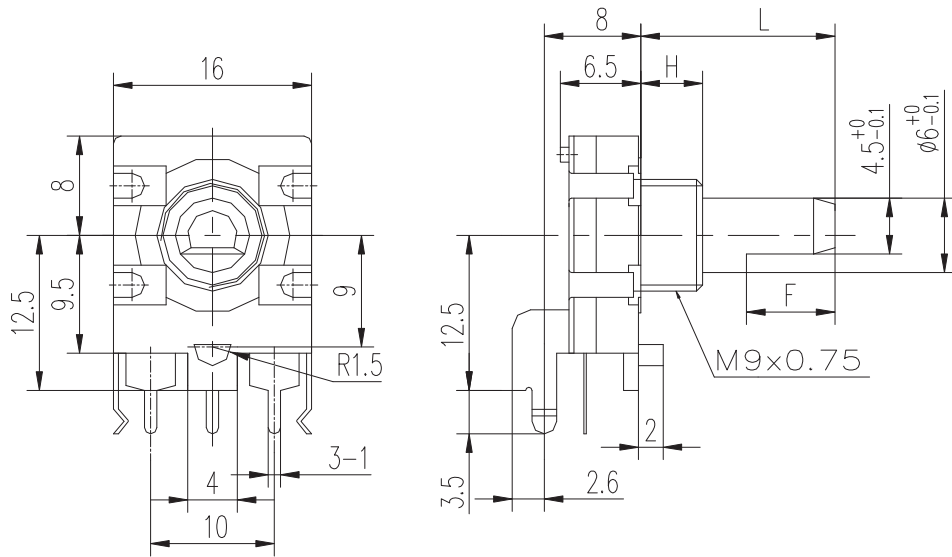
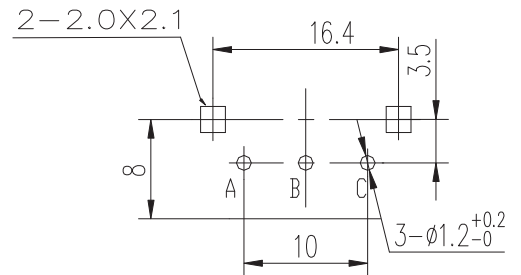
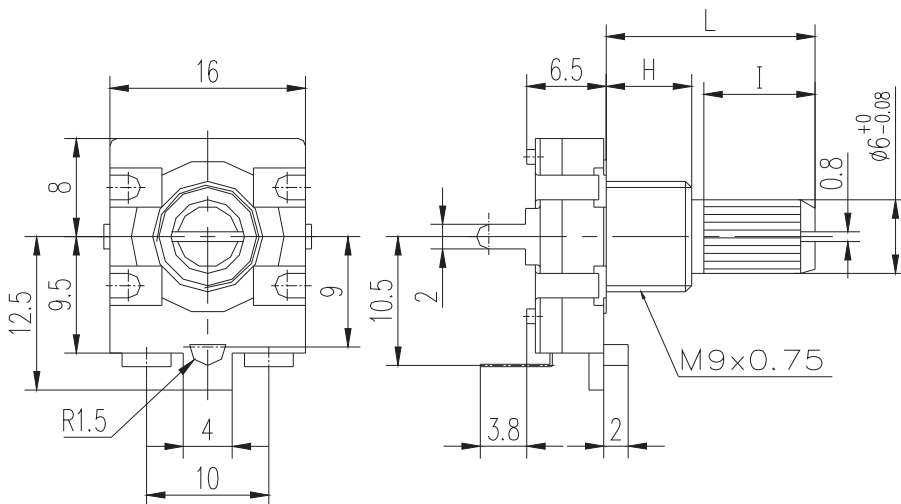
SUGGESTED FILTER

SERIES: ACZ16

DESCRIPTION: mechanical incremental encoder

MECHANICAL DRAWING (horizontal)

PCB LAYOUT

MECHANICAL DRAWING (vertical)

PCB LAYOUT
