

Single Turn Bushing Mount Hall Effect Sensor in Size 09 (22.2 mm)



FEATURES

- Accurate linearity down to: $\pm 0.5\%$
- All electrical angles available up to: 360° (no dead band)
- Long life: greater than 10M cycles
- Non contacting technology: Hall effect
- Model dedicated to all applications in harsh environments



ELECTRICAL SPECIFICATIONS		
PARAMETER	STANDARD	SPECIAL
Electrical Angle	90°, 180°, 270°, 360°	Any other angle upon request
Linearity	$\pm 1\%$	$\pm 0.5\%$
Supply Voltage	5 V _{DC} $\pm 10\%$	Other upon request
Supply Current	10 mA typical	16 mA for PWM output
Output Signal	Analog ratiometric 10 % to 90 % of V _{supply} or PWM 10 % to 90 % duty cycle	Other upon request
Over Voltage Protection		+ 20 V _{DC}
Reverse Voltage Protection		- 10 V _{DC}
Load Resistance Recommended	Min. 1 k Ω for analog output and PWM output	
Hysteresis	< 0.2 %	

MECHANICAL SPECIFICATIONS	
PARAMETER	
Mechanical travel	360° continuous, stops upon request: $340^\circ \pm 3^\circ$
Bearing type	Sleeve bearing
Standard	IP 50; other on request
Weight	20 g ± 2 g

ORDERING INFORMATION/DESCRIPTION									
351HE	0	A	1	W	A	1S22	XXXX	BO 10	e1
MODEL	FEATURES	LINEARITY	ELECTRICAL ANGLE	OUTPUT TYPE	OUTPUT SIGNAL	SHAFT TYPE	SPECIAL REQUEST	PACKAGING	LEAD FINISH
0:	Continuous rotation and antirotation pin	A: $\pm 1\%$ B: $\pm 0.5\%$	1: 90° 2: 180° 3: 270° 4: 360° 9: Other angles	W: Wires Z: Custom	A: Analog CW B: Analog CCW C: PWM CW D: PWM CCW Z: Other output	0: 6 mm 1: 6.35 mm 2: 3.175 mm 9: Special P: Plain S: Slotted Z: Other type		Box of 10 pieces	
1:	Continuous rotation and no antirotation pin								
2:	Stops at 340° and antirotation pin								
3:	Stops at 340° and no antirotation pin								
Shaft length from mounting face 22 mm to 72 mm max. per step of 5 mm									

SAP PART NUMBERING GUIDELINES							
351HE	1	B	9	Z	C	0P27	XXXX
MODEL	MECHANICAL FEATURES	LINEARITY	ELECTRICAL ANGLE	OUTPUT TYPE	OUTPUT SIGNAL	SHAFT TYPE	SPECIAL REQUEST



V_{OUT} ANALOG

Operating Temperature	85 °C	125 °C
Diagnostic High Level	96 % min.	96 % min.
Diagnostic Low Level	2 % max.	4 % max.

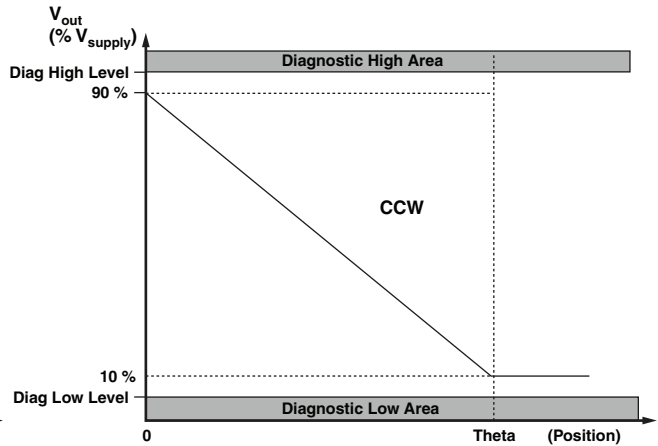
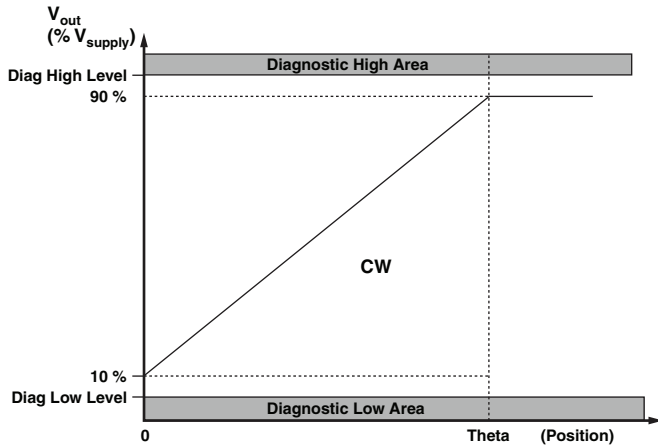

V_{OUT} PWM

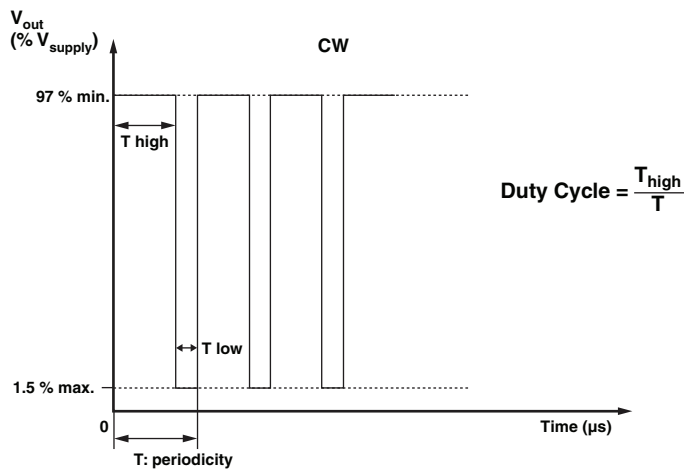

DIAGNOSTIC MODES			
FAILURE	V_{out} Analog $R_{pull-up}$	V_{out} Analog $R_{pull-down}$	V_{out} PWM $R_{pull-up} = 1\text{ k}\Omega$ $V_{pull-up} = V_{supply} = 5\text{ V}$
1: Broken GND	Diagnostic high area	Diagnostic low area	> 97 % V_{supply} without modulation
2: Broken V_{out}	Diagnostic high area	Diagnostic low area	> 97 % V_{supply} without modulation
3: Broken V_{supply}	Diagnostic high area	Diagnostic low area	> 97 % V_{supply} without modulation
Over Voltage $V_{supply} > 7\text{ V}$	Diagnostic high area	Diagnostic low area	> 97 % V_{supply} without modulation
Under Voltage $V_{supply} < 2.7\text{ V}$	Diagnostic high area	Diagnostic low area	> 97 % V_{supply} without modulation

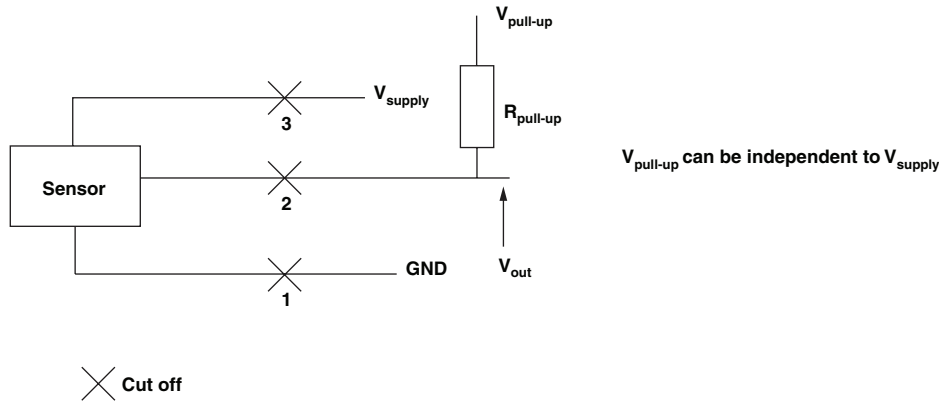

ENVIRONMENTAL SPECIFICATIONS	
Vibrations	20 G from 10 Hz to 2000 Hz
Shocks	3 shocks/axis; 50 G half a sine 11 ms
Operating Temperature Range	- 45 °C; + 125 °C
Life	> 10M of cycles
Rotational Speed (max)	120 rpm
Immunity to Radiated Electromagnetic Disturbances	200 V/m 150 kHz/1 GHz
Immunity to Power Frequency Magnetic Field	200 A/m 50 Hz/60 Hz
Radiated Electromagnetic Emissions	30 MHz/1 GHz < 30 dBμV/m
Electrostatic Discharges	Contact discharges: ± 4 kV Air discharges: ± 8 kV
Materials	
Housing	Thermoplastic housing
Bushing	Brass nickel plated
Shaft	Stainless steel
Output	3 lead wires
Bushing Mount Hardware	
Lockwasher Internal Tooth	Steel nickel plated
Panel Nut	Brass nickel plated



DIMENSIONS in millimeters

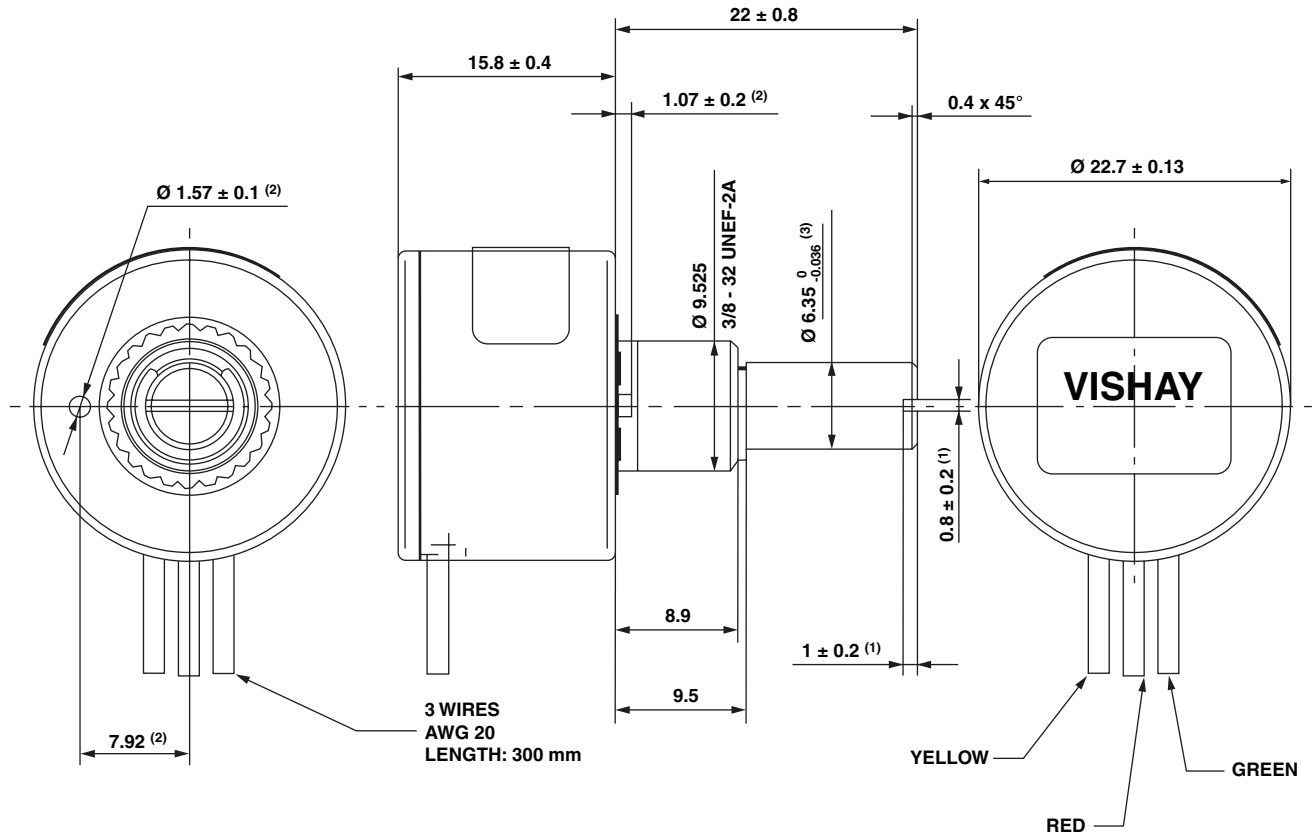

GENERAL TOLERANCE: ± 0.5 mm

CW OR CCW ACCORDING
OUTPUT MODE CHOICE

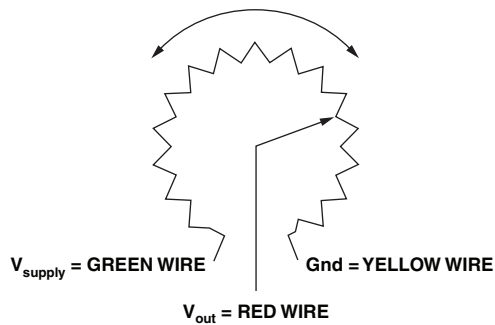

VIEWED FROM SHAFT

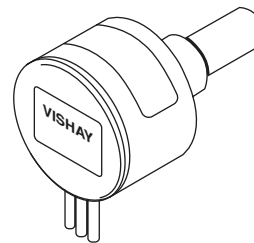

Notes:

- (1) For version slotted shaft
- (2) For version non turn pin
- (3) For shaft type "1"

MARKING	
Unit Identification	Manufacturer's name and complete sap part reference, date code, and wiring correspondance: colors versus connections.



Disclaimer

All product specifications and data are subject to change without notice.

Vishay Intertechnology, Inc., its affiliates, agents, and employees, and all persons acting on its or their behalf (collectively, "Vishay"), disclaim any and all liability for any errors, inaccuracies or incompleteness contained herein or in any other disclosure relating to any product.

Vishay disclaims any and all liability arising out of the use or application of any product described herein or of any information provided herein to the maximum extent permitted by law. The product specifications do not expand or otherwise modify Vishay's terms and conditions of purchase, including but not limited to the warranty expressed therein, which apply to these products.

No license, express or implied, by estoppel or otherwise, to any intellectual property rights is granted by this document or by any conduct of Vishay.

The products shown herein are not designed for use in medical, life-saving, or life-sustaining applications unless otherwise expressly indicated. Customers using or selling Vishay products not expressly indicated for use in such applications do so entirely at their own risk and agree to fully indemnify Vishay for any damages arising or resulting from such use or sale. Please contact authorized Vishay personnel to obtain written terms and conditions regarding products designed for such applications.

Product names and markings noted herein may be trademarks of their respective owners.