



Power Bridge Rectifiers

SKB 26

Features

- Square plastic case with isolated metal base plate and wire leads
- Ideal for printed circuit boards
- Blocking voltage up to 1600 V
- High surge currents
- Notch moulded in casing for easy polarity identification
- Easy chassis mounting

Typical Applications

- Single phase rectifiers for power supplies
- Input rectifiers for variable frequency drives
- Rectifiers for DC motor field supplies
- Battery charge rectifiers
- Recommended snubber network:
RC: 0.1 μ F, 50 Ω ($P_R = 1$ W)

- 1) Soldered directly onto a p.c.b. of 100 x 160 mm with tinned tracking of min. 2.5 mm
- 2) Mounted on a painted metal sheet of min. 250 x 250 x 1 mm

V_{RSM}, V_{RRM} V	V_{VRMS} V	$I_D = 18$ A ($T_c = 75$ °C) Types	C_{max} μ F	R_{min} Ω
200	60	SKB 26/02		0,15
400	125	SKB 26/04		0,3
600	185	SKB 26/06		0,4
800	250	SKB 26/08		0,5
1000	310	SKB 26/10		0,65
1200	380	SKB 26/12		0,75
1400	440	SKB 26/14		0,9
1600	500	SKB 26/16		1

Symbol	Conditions	Values	Units
I_D	$T_a = 45$ °C, isolated ¹⁾	3,5	A
	$T_a = 45$ °C, chassis ²⁾	10	A
I_{DCL}	$T_a = 45$ °C, isolated ¹⁾	3	A
	$T_a = 45$ °C, chassis ²⁾	9,5	A
	$T_a = 45$ °C, P1A/120	14	A
I_{FSM}	$T_{vj} = 25$ °C, 10 ms	370	A
	$T_{vj} = 150$ °C, 10 ms	320	A
i^2t	$T_{vj} = 25$ °C, 8,3 ... 10 ms	680	A ² s
	$T_{vj} = 150$ °C, 8,3 ... 10 ms	500	A ² s
V_F	$T_{vj} = 25$ °C, $I_F = 150$ A	max. 2,2	V
$V_{(TO)}$	$T_{vj} = 150$ °C	max. 0,85	V
r_T	$T_{vj} = 150$ °C	max. 12	m Ω
I_{RD}	$T_{vj} = 25$ °C, $V_{RD} = V_{RRM}$	300	μ A
	$T_{vj} = 150$ °C, $V_{RD} = V_{RRM} \geq V$		μ A
I_{RD}	$T_{vj} = 25$ °C, $V_{RD} = V_{RRM}$	5	mA
	$T_{vj} = 150$ °C, $V_{RD} = V_{RRM} \geq V$		mA
t_{rr}	$T_{vj} = 25$ °C	10	μ s
f_G		2000	Hz
$R_{th(j-a)}$	isolated ¹⁾	15	K/W
	chassis ²⁾	4,7	K/W
	total	1,9	K/W
	total	0,15	K/W
T_{vj}		- 40 ... + 150	°C
T_{stg}		- 55 ... + 150	°C
V_{isol}	a. c. 50 ... 60 Hz; r.m.s.; 1 s / 1 min. to heatsink	3000 / 2500	V~
M_s		2 \pm 15 %	Nm
M_t			Nm
a			m/s ²
w		20	g
Fu		20	A
Case		G 50a	

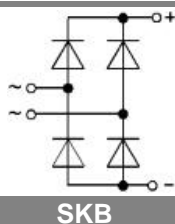

SKB

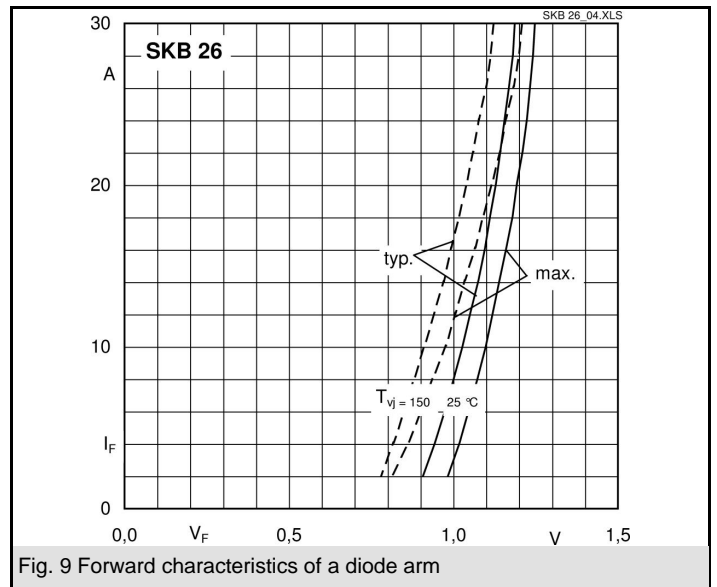
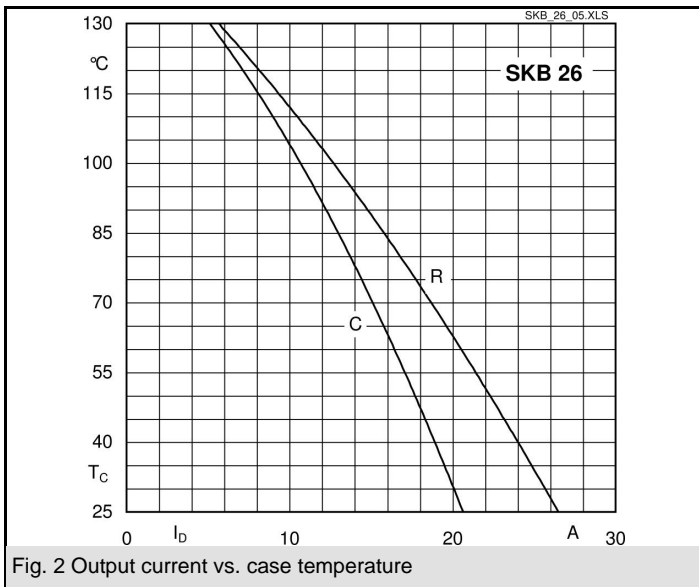
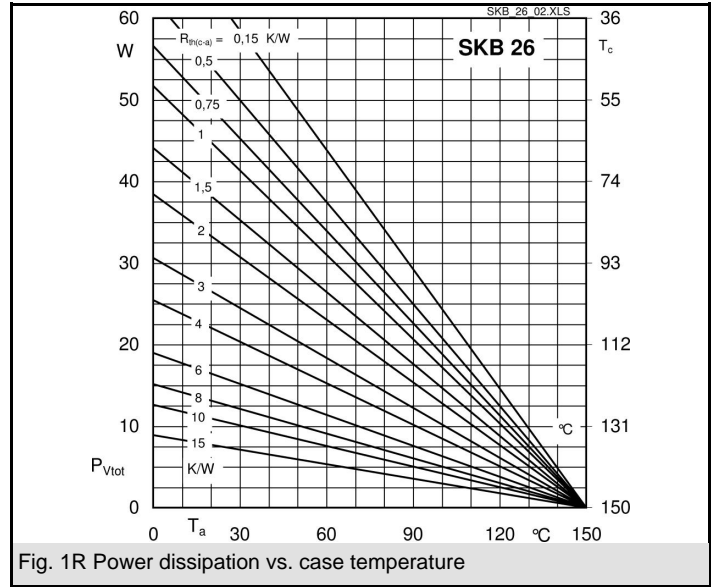
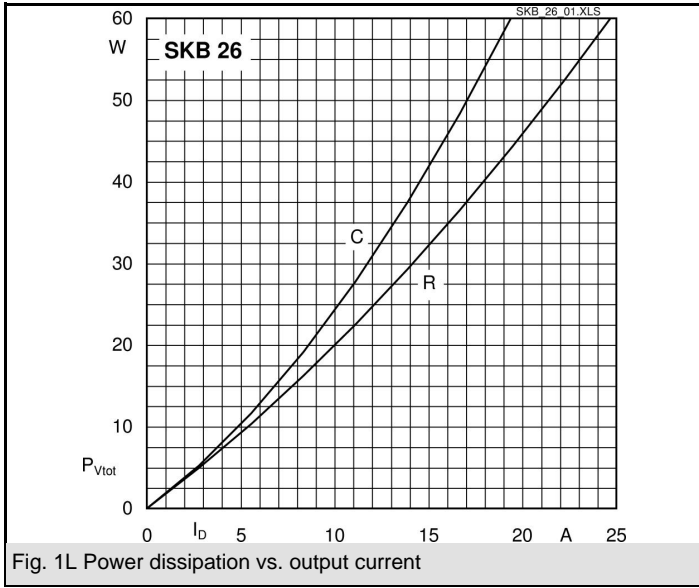

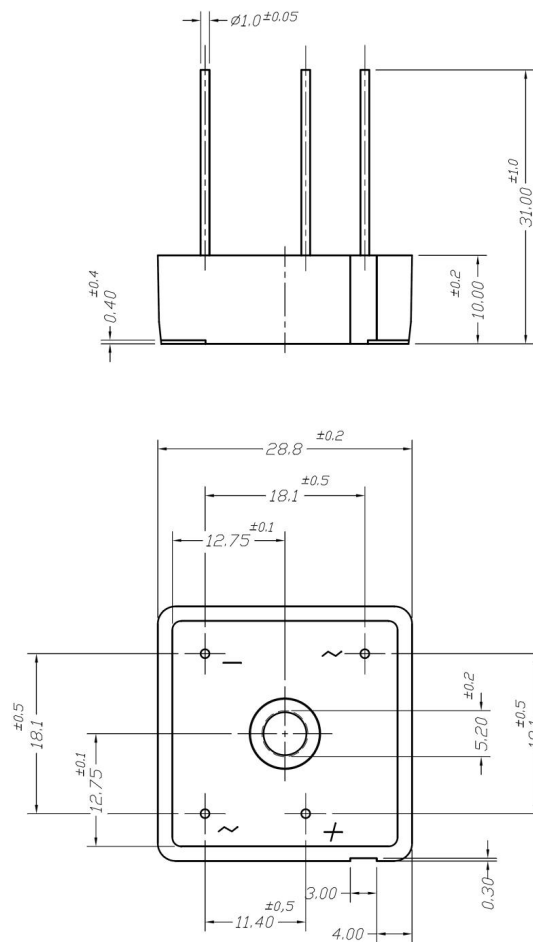

Case G 50a

This technical information specifies semiconductor devices but promises no characteristics. No warranty or guarantee expressed or implied is made regarding delivery, performance or suitability.