

Silicon NPN Power Transistors

2SD1290

DESCRIPTION

- With TO-3PN package
- Built-in damper diode
- High voltage ,high reliability
- Wide area of safe operation

APPLICATIONS

- For color TV horizontal deflection output applications

PINNING

PIN	DESCRIPTION
1	Base
2	Collector;connected to mounting base
3	Emitter

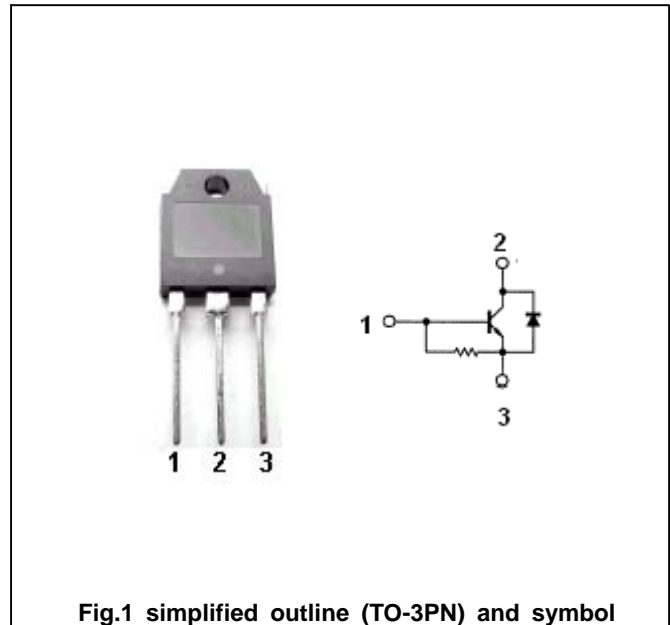

Fig.1 simplified outline (TO-3PN) and symbol

Absolute maximum ratings (Ta=25)

SYMBOL	PARAMETER	CONDITIONS	VALUE	UNIT
V _{CB0}	Collector-base voltage	Open emitter	1500	V
V _{EBO}	Emitter-base voltage	Open collector	5	V
I _C	Collector current (DC)		3	A
I _{CM}	Collector current (Pulse)		10	A
P _C	Collector power dissipation	T _C =25	50	W
T _j	Junction temperature		130	
T _{stg}	Storage temperature		-55~130	

Silicon NPN Power Transistors

2SD1290

CHARACTERISTICS

T_j=25 unless otherwise specified

SYMBOL	PARAMETER	CONDITIONS	MIN	TYP.	MAX	UNIT
V _{EBO}	Emitter-base breakdown voltage	I _E =500mA; I _C =0	5			V
V _{CEsat}	Collector-emitter saturation voltage	I _C =2A; I _B =0.75A			5.0	V
V _{BEsat}	Base-emitter saturation voltage	I _C =2A; I _B =0.75A			1.5	V
I _{CBO}	Collector cut-off current	V _{CB} =750V; I _E =0			50	μA
		V _{CB} =1500V; I _E =0			1	mA
h _{FE}	DC current gain	I _C =2A; V _{CE} =10V	3		8	
t _s	Storage time	I _C =2A I _{Leak} =0.75A, L _B =5 μH	3		7	μs
t _f	Fall time				1	μs
V _F	Diode forward voltage	I _F =-4A, I _B =0			2.2	V

Silicon NPN Power Transistors

2SD1290

PACKAGE OUTLINE

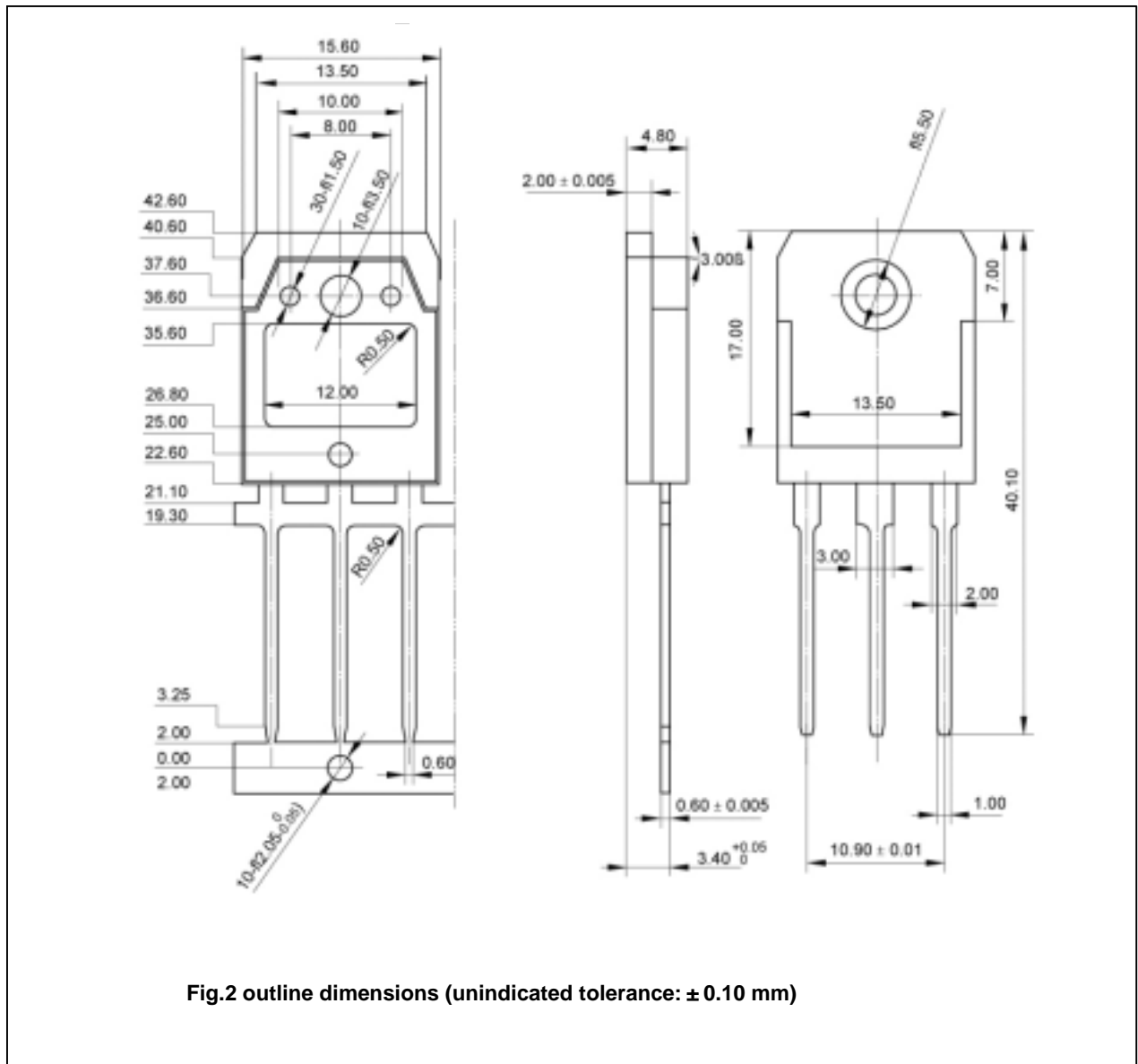

Fig.2 outline dimensions (unindicated tolerance: ± 0.10 mm)