

150mA/300mA Low Dropout Linear Regulator with 1% Output Accuracy

FEATURES

- Low dropout voltage of 130mV at 100mA output current (5V output version).
- Guaranteed 150mA/300mA output current.
- Internal 1.3Ω P-MOSFET draws no base-current.
- Low ground current of 55μA.
- Output voltage accuracy of 1% at 3.3V/5V.
- Input voltage range up to 12V (5V output version)
- Extremely tight load and line regulation.
- Fast transient response.
- Current limiting and thermal protection.

 **RoHS compliant.**

APPLICATIONS

- LAN Cards.
- Wireless Communication Systems.
- Battery Powered Systems.

DESCRIPTION

The SS6721/6721D are 150/300mA low dropout linear regulators. The superior characteristics of the SS6721 and SS6721D include zero base-current loss, very low dropout voltage, and 1% accuracy of output voltage. Typical ground current is approximately 55μA, across the load range from zero to maximum. With an output current of 100mA, the dropout voltage of the SS6721 and SS6721D is substantially lower (130mV for SS6721-50 and SS6721D-50, and 180mV for the SS6721-33 and SS6721D-33) when compared with a bipolar device. Built-in output current and thermal limiting provide maximum protection of the SS6721 and SS6721D against fault conditions.

The SS6721 and SS6721D are available in the popular SOT-89 and TO-92 packages.

TYPICAL APPLICATION CIRCUIT

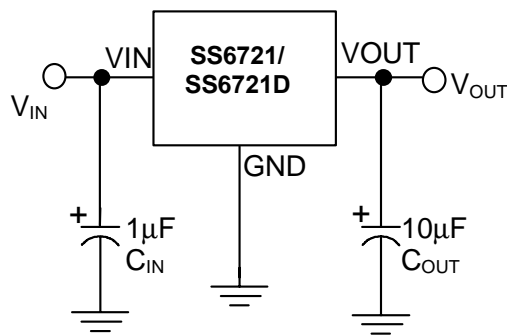

Low Dropout Linear Regulator

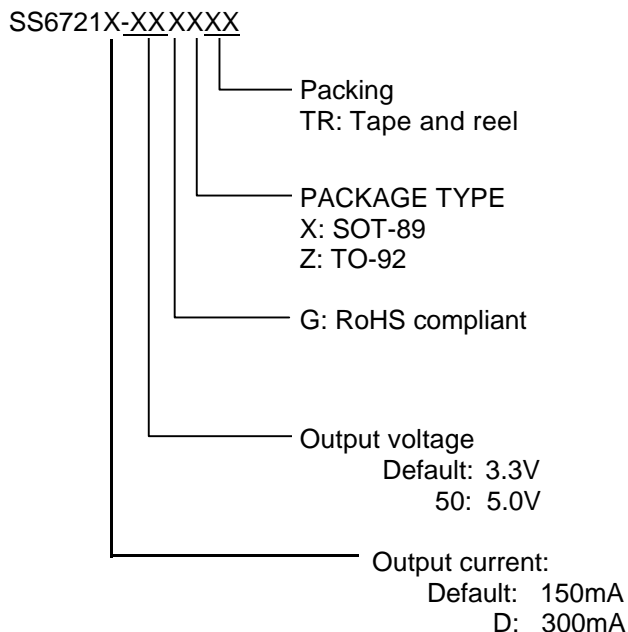
ORDERING INFORMATION

PIN CONFIGURATION

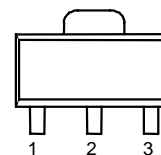
SOT-89
Front view
1. VOUT
2. GND
3. VIN

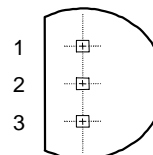

TO-92
Front view
1. VOUT
2. GND
3. VIN



Example: SS6721GXTR
150mA, 3.3V version, in RoHS-compliant SOT-89,
shipped on tape and reel

SS6721D-50GZTR
300mA, 5.0V version, in RoHS-compliant TO-92,
shipped on tape and reel

SOT89 Marking

Part No.	Marking	Part No.	Marking
SS6721GX	AF33P	SS6721DGX	AG33P
SS6721-50GX	AF50P	SS6721D-50GX	AG50P

ABSOLUTE MAXIMUM RATINGS

Input Supply Voltage.....	-0.3~12V
Operating Junction Temperature Range.....	-40°C~ 85°C
Maximum Junction Temperature.....	125°C
Storage Temperature Range	-65°C~150°C
Power Dissipation	
SOT-89 Package.....	0.80W
TO-92 Package.....	0.78W
Lead Temperature (Soldering) 10 sec.....	260°C

Exceeding the Absolute Maximum Ratings may impair the life of a device.

TEST CIRCUIT

Refer to the TYPICAL APPLICATION CIRCUIT

ELECTRICAL CHARACTERISTICS

($T_j = 25^\circ\text{C}$, $C_{IN} = 1\mu\text{F}$, $C_{OUT} = 10\mu\text{F}$, unless otherwise specified.)

PARAMETER	TEST CONDITIONS	MIN.	TYP.	MAX.	UNIT
Output Voltage	SS6721/6721D-50 $V_{IN}=5.5$ to 12V, $I_{OUT}=0\text{mA}$	4.950	5.0	5.050	V
	SS6721/6721D $V_{IN}=3.6$ to 12V, $I_{OUT}=0\text{mA}$	3.267	3.3	3.333	
Output Voltage Temperature Coefficient	(Note 1)		50	150	PPM/ $^\circ\text{C}$
Line Regulation	$I_{OUT}=1\text{mA}$ SS6721/6721D-50 $V_{IN}=5.5$ to 12V		3	10	mV
	SS6721/6721D $V_{IN}=3.6$ to 12V		3	10	
Load Regulation (Note 2)	SS6721-50 $V_{IN}=7\text{V}$, $I_{OUT}=0.1$ to 150mA		7	15	mV
	SS6721D-50 $V_{IN}=7\text{V}$, $I_{OUT}=0.1$ to 300mA		7	25	
	SS6721 $V_{IN}=5\text{V}$, $I_{OUT}=0.1$ to 150mA		7	15	
	SS6721D $V_{IN}=5\text{V}$, $I_{OUT}=0.1$ to 300mA		7	25	
Current Limit (Note 3)	SS6721-50 $V_{IN}=7\text{V}$, $V_{OUT}=0\text{V}$	300	440		mA
	SS6721 $V_{IN}=5\text{V}$, $V_{OUT}=0\text{V}$	300	440		
	SS6721D-50 $V_{IN}=7\text{V}$, $V_{OUT}=0\text{V}$	300	440		
	SS6721D $V_{IN}=5\text{V}$, $V_{OUT}=0\text{V}$	300	440		
Dropout Voltage (Note 4)	SS6721-50 $I_{OUT}=150\text{mA}$		200	300	mV
	SS6721 $I_{OUT}=150\text{mA}$		270	370	
	SS6721D-50 $I_{OUT}=300\text{mA}$		400	500	
	SS6721D $I_{OUT}=300\text{mA}$		540	640	
Ground Current	$I_{OUT}=0.1\text{mA}$ to I_{MAX} SS6721/6721D-50 $V_{IN}=5.5$ to 12V		55	80	μA
	SS6721/6721D $V_{IN}=4$ to 12V		55	80	

Note 1: Guaranteed by design.

Note 2: Regulation is measured at a constant junction temperature, which is maintained using pulse testing.

Note 3: Current limit is measured by pulse testing.

Note 4: Dropout voltage is defined as voltage differential at which the output voltage drops 100mV with an initial 1V differential between input and output.

Note 5: Specifications over -40°C to 85°C operating temperature range are guaranteed by design with Statistical Quality Controls (SQC), not production test.

TYPICAL PERFORMANCE CHARACTERISTICS

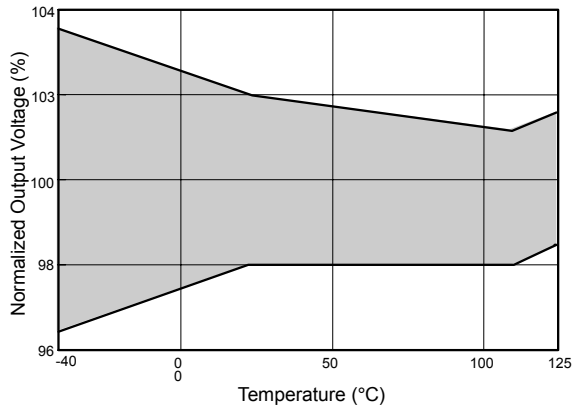

Fig. 1 Output Voltage vs. Temperature

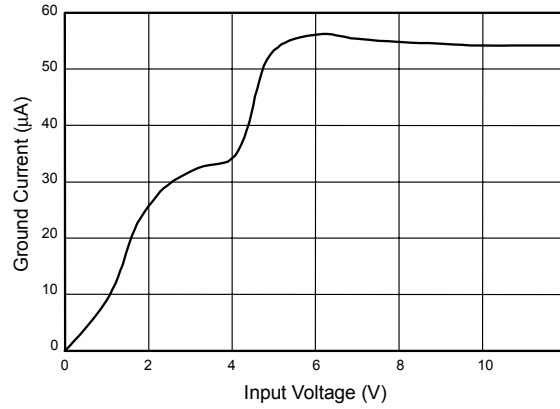

Fig. 2 Ground Current vs. Input Voltage

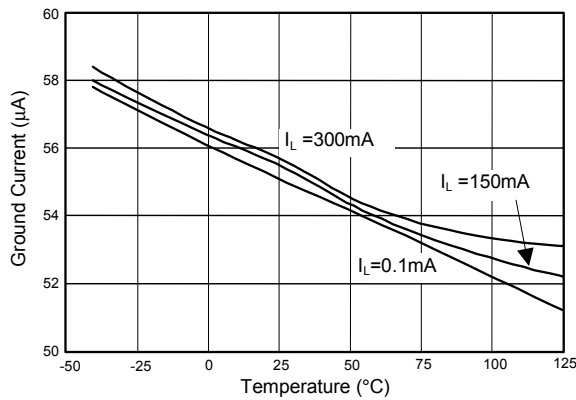

Fig. 3 Ground Current vs. Temperature

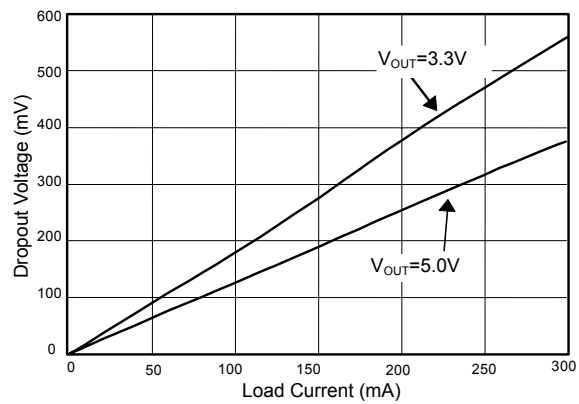

Fig. 4 Dropout Voltage vs. Load Current

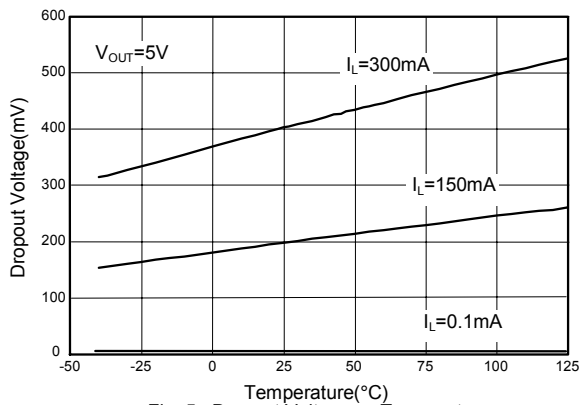

Fig. 5 Dropout Voltage vs. Temperature

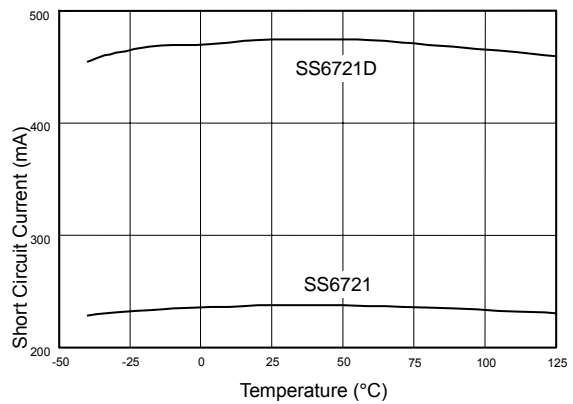

Fig. 6 Short Circuit Current vs. Temperature

TYPICAL PERFORMANCE CHARACTERISTICS (Continued)

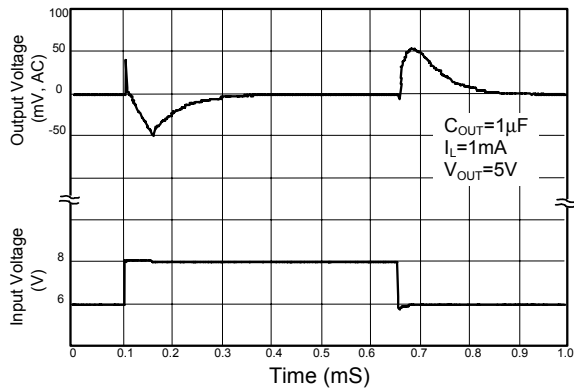

Fig. 7 Line Transient Response

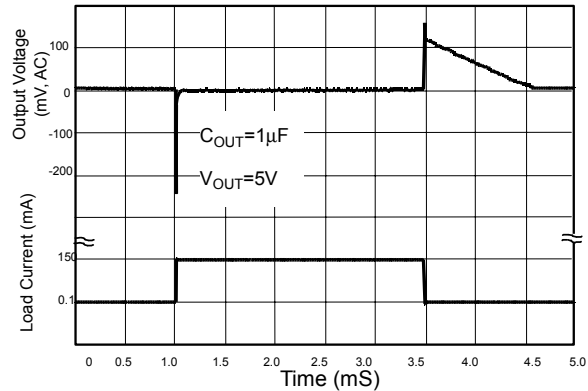

Fig. 8 Load Transient Response

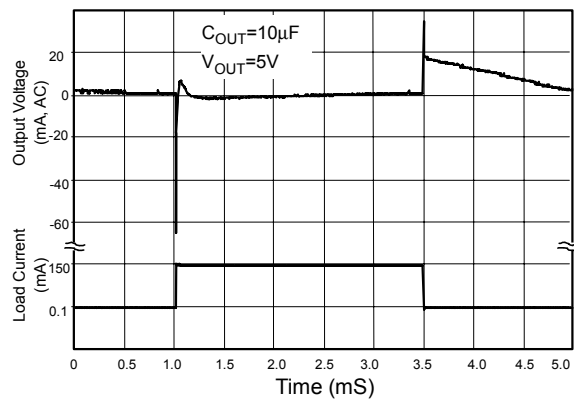
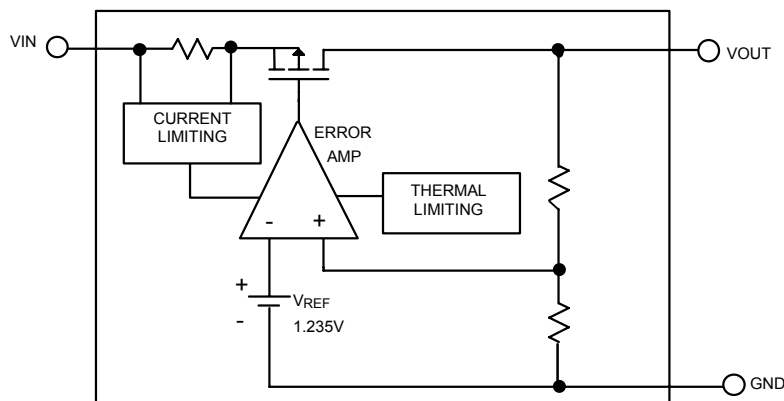

Fig. 9 Load Transient Response

BLOCK DIAGRAM



PIN DESCRIPTIONS

- VOUT PIN - Output pin.
- GND PIN - Power GND.
- VIN PIN - Power Supply Input.

PHYSICAL DIMENSIONS (unit: mm)

SOT-89

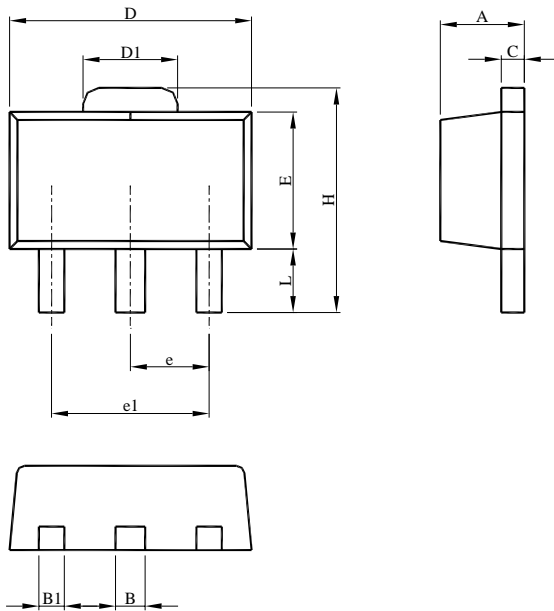

SOT-89		
MILLIMETERS		
SYMBOL	MIN.	MAX.
A	1.40	1.60
B	0.44	0.56
B1	0.36	0.48
C	0.35	0.44
D	4.40	4.60
D1	1.50	1.83
E	2.29	2.60
e	1.50 BSC	
e1	3.00 BSC	
H	3.94	4.25
L	0.89	1.20

TO-92

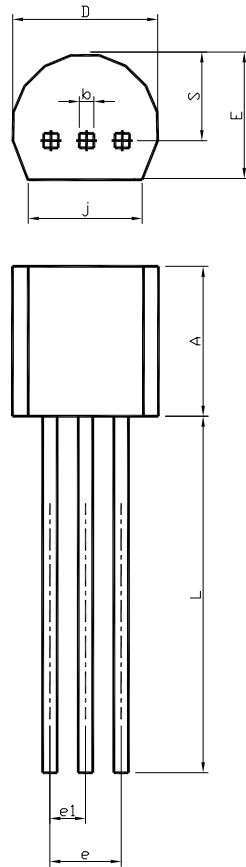

SYMBOL	TO-92	
	MILLIMETERS	
	MIN.	MAX.
A	4.32	5.33
b	0.36	0.47
D	4.45	5.20
E	3.18	4.19
e	2.42	2.66
e1	1.15	1.39
j	3.43	
L	12.70	
S	2.03	2.66

Information furnished by Silicon Standard Corporation is believed to be accurate and reliable. However, Silicon Standard Corporation makes no guarantee or warranty, express or implied, as to the reliability, accuracy, timeliness or completeness of such information and assumes no responsibility for its use, or for infringement of any patent or other intellectual property rights of third parties that may result from its use. Silicon Standard reserves the right to make changes as it deems necessary to any products described herein for any reason, including without limitation enhancement in reliability, functionality or design. No license is granted, whether expressly or by implication, in relation to the use of any products described herein or to the use of any information provided herein, under any patent or other intellectual property rights of Silicon Standard Corporation or any third parties.