

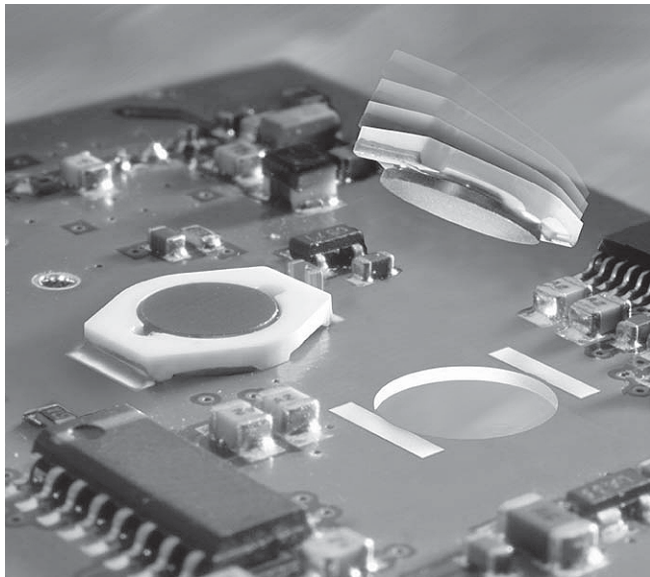

SMT Power Inductors - LPO2506 Series



- On-board style – 1.65 mm high
- InBoard® style – only 1.19 mm high

Designer's Kit C332 contains 3 of all InBoard® styles

Designer's Kit C333 contains 3 of all On-board styles

Core material Ferrite

Core and winding loss See www.coilcraft.com/coreloss

Terminations RoHS compliant silver-palladium-platinum-glass frit. Other terminations available at additional cost.

Weight 240 – 260 mg

Ambient temperature –40°C to +85°C with I_{rms} current, +85°C to +125°C with derated current

Storage temperature Component: –40°C to +125°C.

Packaging: –40°C to +80°C

Resistance to soldering heat Max three 40 second reflows at +260°C, parts cooled to room temperature between cycles

Moisture Sensitivity Level (MSL) 1 (unlimited floor life at <30°C / 85% relative humidity)

Failures in Time (FIT) / Mean Time Between Failures (MTBF)

38 per billion hours / 26,315,789 hours, calculated per Telcordia SR-332

Packaging 1000/13" reel Plastic tape: 12 mm wide, 0.23 mm thick, 8 mm pocket spacing, 1.37 mm pocket depth

PCB washing Only pure water or alcohol recommended

InBoard style part number ¹	On-board style part number ¹	L ±20% ² (µH)	DCR max (Ohms)	SRF typ (MHz)	Isat ³ (A)	I _{rms} ⁴ (A)
LPO2506I-472L_	LPO2506O-472L_	4.7	0.145	90	1.6	1.9
LPO2506I-682L_	LPO2506O-682L_	6.8	0.165	75	1.3	1.7
LPO2506I-822L_	LPO2506O-822L_	8.2	0.200	65	1.0	1.5
LPO2506I-103L_	LPO2506O-103L_	10	0.240	60	1.0	1.5
LPO2506I-153L_	LPO2506O-153L_	15	0.300	45	0.90	1.3
LPO2506I-223L_	LPO2506O-223L_	22	0.420	35	0.70	1.0
LPO2506I-333L_	LPO2506O-333L_	33	0.550	30	0.60	0.90
LPO2506I-473L_	LPO2506O-473L_	47	0.765	22	0.50	0.70
LPO2506I-683L_	LPO2506O-683L_	68	1.10	20	0.40	0.60
LPO2506I-104L_	LPO2506O-104L_	100	1.60	15	0.30	0.50
LPO2506I-154L_	LPO2506O-154L_	150	2.50	12	0.25	0.40
LPO2506I-224L_	LPO2506O-224L_	220	3.65	10	0.22	0.32
LPO2506I-334L_	LPO2506O-334L_	330	4.65	8.0	0.18	0.28
LPO2506I-474L_	LPO2506O-474L_	470	6.75	6.5	0.14	0.24
LPO2506I-684L_	LPO2506O-684L_	680	9.15	5.5	0.12	0.20
LPO2506I-105L_	LPO2506O-105L_	1000	14.20	4.5	0.10	0.16

1. When ordering, please specify **termination** and **packaging** codes:

LPO2506O-105L D

Termination: L = RoHS compliant silver-palladium-platinum-glass frit
Special order: T = RoHS tin-silver-copper (95.5/4/0.5) or S = non-RoHS tin-lead (63/37).

Packaging: D = 13" machine-ready reel. EIA-481 embossed plastic tape (1000 parts per full reel).

B = Less than full reel. In tape, but not machine ready.
 To have a leader and trailer added (\$25 charge), use code letter D instead.

2. Inductance tested at 100 kHz, 0.1 V_{rms}, 0 Adc using an Agilent/HP 4263B LCR meter or equivalent.

3. DC current at which the inductance drops 10% (typ) from its value without current.

4. Current that causes a 40°C temperature rise from 25°C ambient.

5. Electrical specifications at 25°C.

Refer to Doc 362 "Soldering Surface Mount Components" before soldering.

SPICE models ON OUR WEB SITE OR CD

Coilcraft®

Specifications subject to change without notice.
 Please check our website for latest information.

Document 208-1 Revised 10/14/08

1102 Silver Lake Road Cary, Illinois 60013 Phone 847/639-6400 Fax 847/639-1469

E-mail info@coilcraft.com Web <http://www.coilcraft.com>



SMT Power Inductors - LPO2506 Series

Typical L vs Frequency

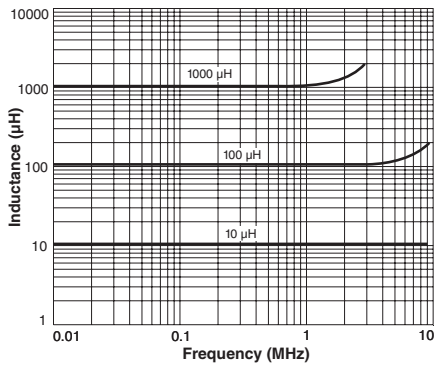

Typical L vs Current

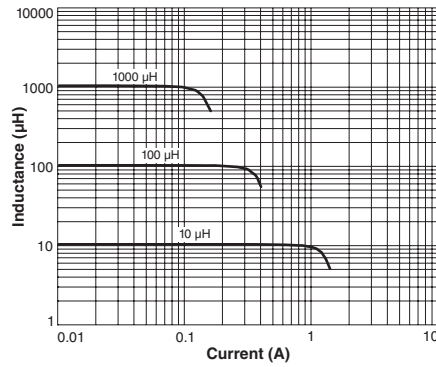

Current Derating

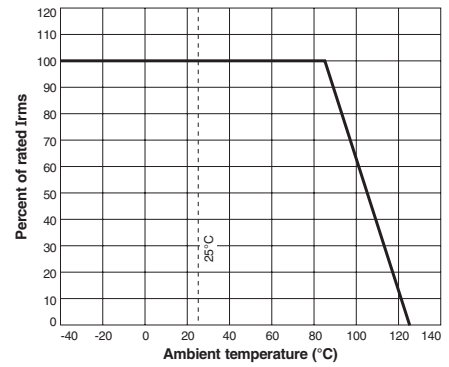

On-board Style

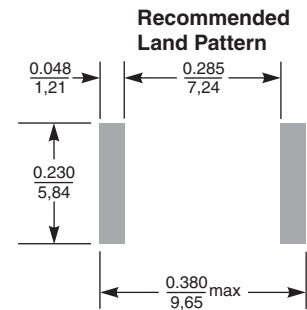
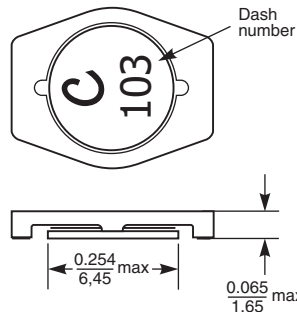
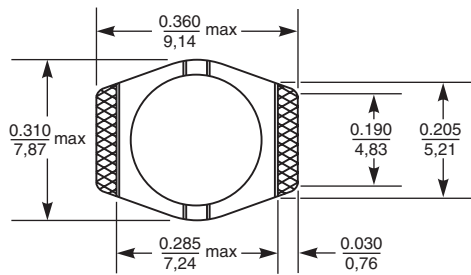

InBoard Style

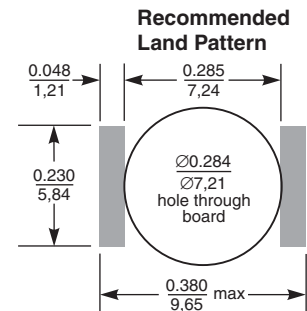
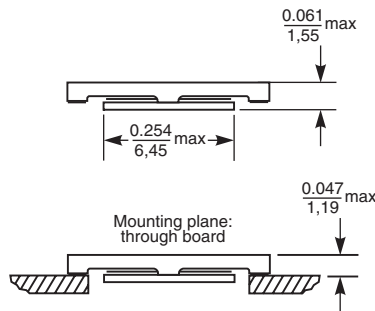
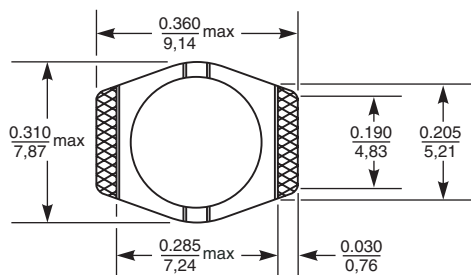

Specifications subject to change without notice. Please check our website for latest information.

Document 208-2 Revised 10/14/08

1102 Silver Lake Road Cary, Illinois 60013 Phone 847/639-6400 Fax 847/639-1469

E-mail info@coilcraft.com Web http://www.coilcraft.com