

Features

- * Package in 8mm tape on 7" diameter reels.
- * Compatible with automatic placement equipment.
- * Compatible with infrared and vapor phase reflow solder process.
- * EIA STD package.
- * I.C. compatible.
- * Meet green product and Pb-free(According to RoHS)

Package Dimensions

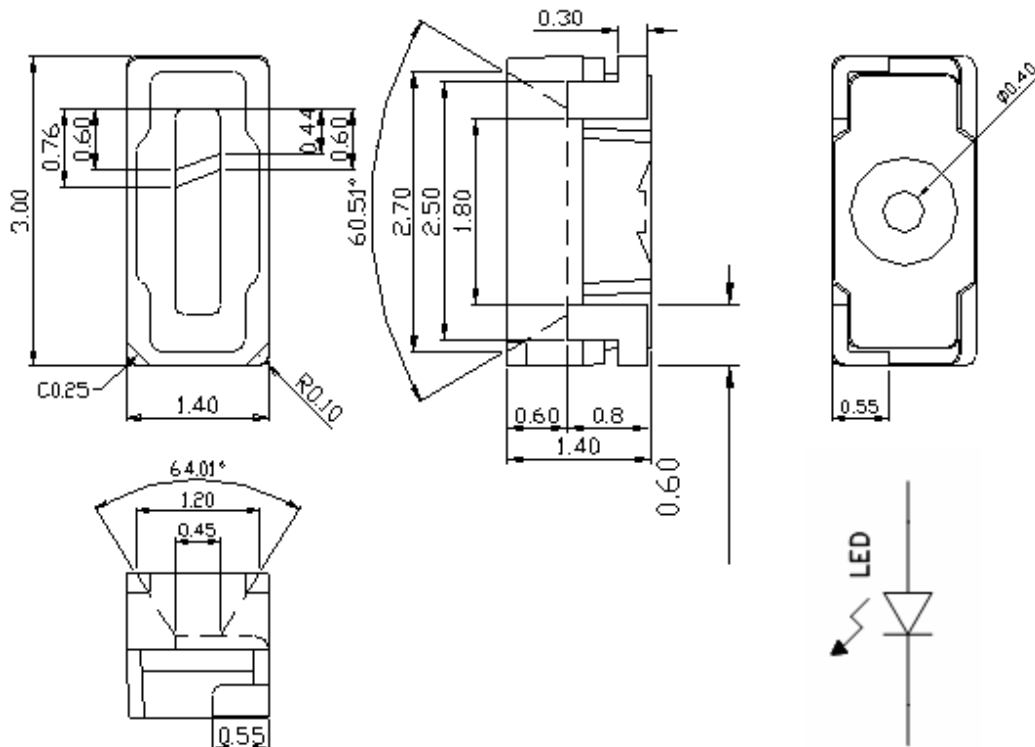

Part No.	Lens Color	Source Color
LTW-089E2CG-A	Yellow	InGaN White

Notes:

1. All dimensions are in millimeters (inches).
2. Tolerance is ± 0.1 mm (.004") unless otherwise noted.

Definition of Distance Between of PAD and Reflector

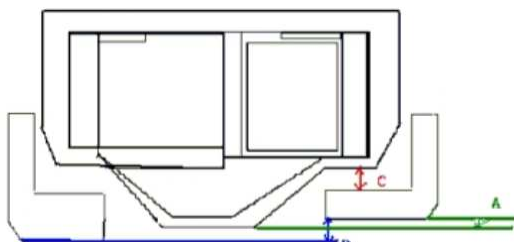

	Symbol	Dimension (mm)	
A: The distance between pad's bottom and reflector.	A	0 min	0.05 max
B: The tolerance between right and left pad.	B	0 min	0.03 max
C: The distance between pad and reflector.	C	0 min	0.05 max

Property of Lite-On Only

Absolute Maximum Ratings at Ta=25°C

Parameter	LTW-089E2CG-A	Unit
Power Dissipation (30mA, 4V)	120	mW
Power Dissipation (20mA, 3.5V)	70	mW
Peak Forward Current (1/10 Duty Cycle, 0.1ms Pulse Width)	100	mA
DC Forward Current	30	mA
Reverse Voltage	5	V
Operating Temperature Range	-30°C to +85°C	
Storage Temperature Range	-40°C to +100°C	
Reflow Soldering Condition	260°C For 10 Seconds	

Suggest IR Reflow Condition :

R-Reflow Soldering Profile for lead free soldering (Acc. to J-STD-020B)

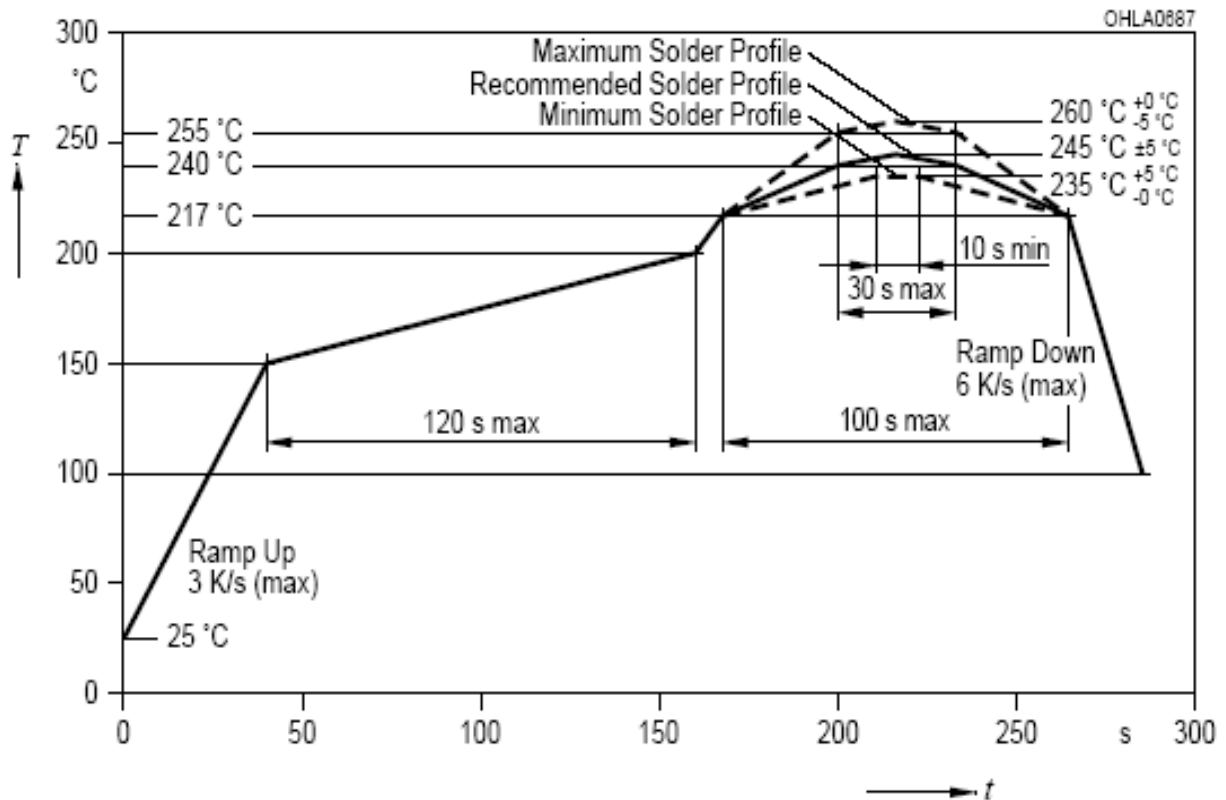

Electrical Optical Characteristics At Ta=25°C

Parameter	Symbol	Part No. LTW-	Min.	Typ.	Max.	Unit	Test Condition
Luminous Flux	lm	089E2CG-A	4.0		6.6	lm	IF = 20mA Note 1, 2
Luminous Intensity	Iv	089E2CG-A		2000			IF = 20mA Note 1, 2
Viewing Angle	2θ 1/2	089E2CG-A		120		deg	Fig.6
Chromaticity Coordinates	x	089E2CG-A		0.300			IF = 20mA Note 3, 5, 6
	y			0.285			
Forward Voltage	VF	089E2CG-A	3.0	3.2	3.4	V	IF = 20mA
ESD-Withstand Voltage	ESD	089E2CG-A	1K			V	HBM

Note : 1. Luminous Flux is measured with a light sensor and filter combination that approximates the CIE eye-response curve.

2. Flux classification code is marked on each packing bag.

3. The chromaticity coordinates (x, y) is derived from the 1931 CIE chromaticity diagram.

4. Caution in ESD:

Static Electricity and surge damages the LED. It is recommend to use a wrist band or anti-electrostatic glove when handling the LED. All devices, equipment and machinery must be properly grounded.

5. CAS140B is the test standard for the chromaticity coordinates (x, y)

6. Chromaticity coordinates (x, y) is tested by IS.

7. The chromaticity coordinates (x, y) guarantee should be added +/- 0.005 tolerance.

Bin Code List

Luminous Spec. Table				
IV Bin	Flux (lm) and IV (mcd) at IF = 20mA			
	lm		mcd	
	Min.	Max.	Min.	Max.
5	4.0	4.3	1550	1650
6	4.3	4.6	1650	1750
7	4.6	4.9	1750	1850
8	4.9	5.3	1850	2000
9	5.3	5.7	2000	2150
10	5.7	6.1	2150	2300
11	6.1	6.6	2300	2500

Tolerance on each Luminous Intensity bin and Luminous Flux are +/- 7%, and IV (mcd) is for reference.

C. I. E. 1931 Chromaticity Diagram @20mA

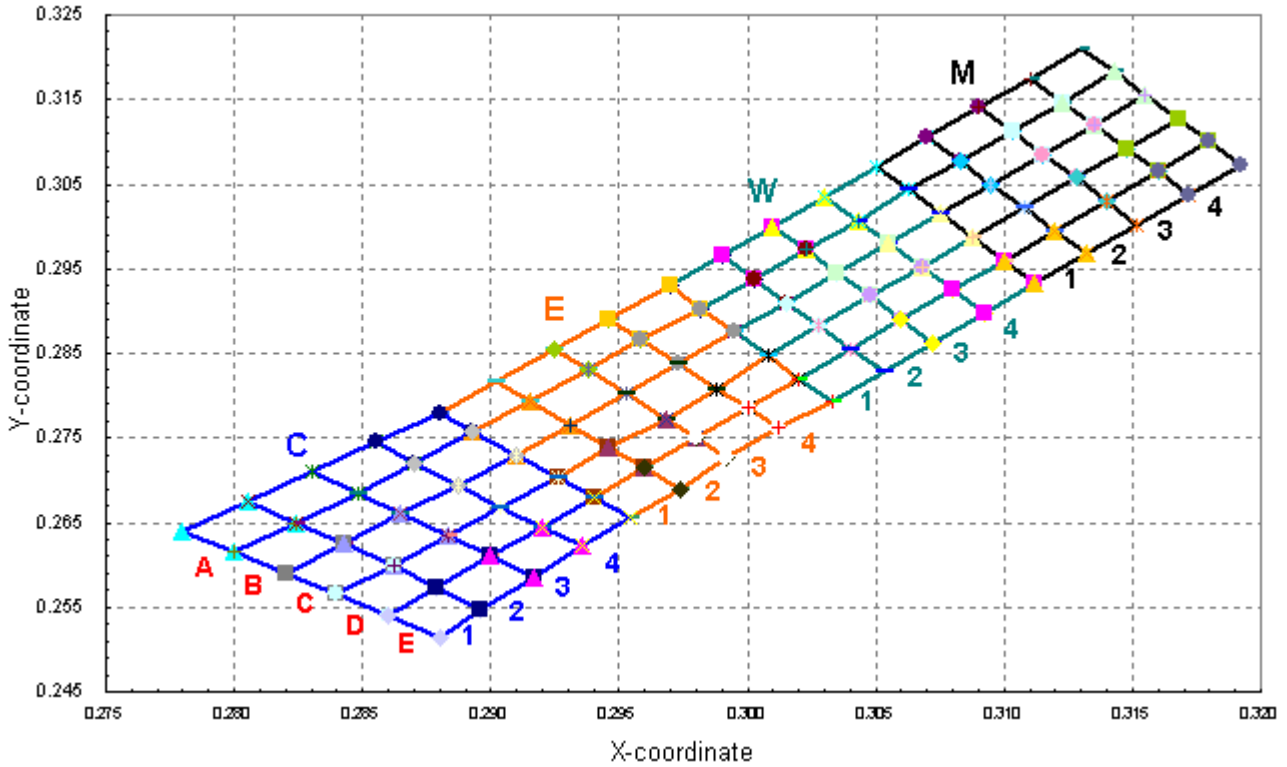

Property of Lite-On Only

Color Spec. Table @20mA

CA1		CA2		CA3		CA4	
x	y	x	y	x	y	x	y
0.2800	0.2615	0.2824	0.2649	0.2848	0.2684	0.2870	0.2720
0.2780	0.2640	0.2805	0.2675	0.2830	0.2710	0.2855	0.2745
0.2805	0.2675	0.2830	0.2710	0.2855	0.2745	0.2880	0.2780
0.2824	0.2649	0.2848	0.2684	0.2870	0.2720	0.2893	0.2758
CB1		CB2		CB3		CB4	
0.2820	0.2590	0.2843	0.2625	0.2865	0.2660	0.2887	0.2694
0.2800	0.2615	0.2824	0.2649	0.2848	0.2684	0.2870	0.2720
0.2824	0.2649	0.2848	0.2684	0.2870	0.2720	0.2893	0.2758
0.2843	0.2625	0.2865	0.2660	0.2887	0.2694	0.2910	0.2730
CC1		CC2		CC3		CC4	
0.2840	0.2565	0.2862	0.2598	0.2883	0.2634	0.2904	0.2668
0.2820	0.2590	0.2843	0.2625	0.2865	0.2660	0.2887	0.2694
0.2843	0.2625	0.2865	0.2660	0.2887	0.2694	0.2910	0.2730
0.2862	0.2598	0.2883	0.2634	0.2904	0.2668	0.2926	0.2703
CD1		CD2		CD3		CD4	
0.2860	0.2540	0.2879	0.2573	0.2900	0.2610	0.2920	0.2645
0.2840	0.2565	0.2862	0.2598	0.2883	0.2634	0.2904	0.2668
0.2862	0.2598	0.2883	0.2634	0.2904	0.2668	0.2926	0.2703
0.2879	0.2573	0.2900	0.2610	0.2920	0.2645	0.2940	0.2680
CE1		CE2		CE3		CE4	
0.2860	0.2540	0.2879	0.2573	0.2900	0.2610	0.2920	0.2645
0.2880	0.2515	0.2896	0.2548	0.2917	0.2586	0.2936	0.2622
0.2896	0.2548	0.2917	0.2586	0.2936	0.2622	0.2954	0.2657
0.2879	0.2573	0.2900	0.2610	0.2920	0.2645	0.2940	0.2680
EA1		EA2		EA3		EA4	
x	y	x	y	x	y	x	y
0.2893	0.2758	0.2915	0.2794	0.2938	0.2831	0.2958	0.2867
0.2880	0.2780	0.2902	0.2816	0.2925	0.2855	0.2946	0.2890
0.2902	0.2816	0.2925	0.2855	0.2946	0.2890	0.2970	0.2930
0.2915	0.2794	0.2938	0.2831	0.2958	0.2867	0.2982	0.2903
EB1		EB2		EB3		EB4	
0.2910	0.2730	0.2931	0.2765	0.2953	0.2803	0.2973	0.2838
0.2893	0.2758	0.2915	0.2794	0.2938	0.2831	0.2958	0.2867
0.2915	0.2794	0.2938	0.2831	0.2958	0.2867	0.2982	0.2903
0.2931	0.2765	0.2953	0.2803	0.2973	0.2838	0.2995	0.2875
EC1		EC2		EC3		EC4	
0.2926	0.2703	0.2946	0.2738	0.2968	0.2773	0.2988	0.2808
0.2910	0.2730	0.2931	0.2765	0.2953	0.2803	0.2973	0.2838
0.2931	0.2765	0.2953	0.2803	0.2973	0.2838	0.2995	0.2875
0.2946	0.2738	0.2968	0.2773	0.2988	0.2808	0.3008	0.2848
ED1		ED2		ED3		ED4	
0.2940	0.2680	0.2960	0.2714	0.2980	0.2750	0.3000	0.2785
0.2926	0.2703	0.2946	0.2738	0.2968	0.2773	0.2988	0.2808
0.2946	0.2738	0.2968	0.2773	0.2988	0.2808	0.3008	0.2848
0.2960	0.2714	0.2980	0.2750	0.3000	0.2785	0.3020	0.2820
EE1		EE2		EE3		EE4	
0.2940	0.2680	0.2960	0.2714	0.2980	0.2750	0.3000	0.2785
0.2954	0.2657	0.2974	0.2690	0.2992	0.2727	0.3012	0.2762
0.2974	0.2690	0.2992	0.2727	0.3012	0.2762	0.3033	0.2793
0.2960	0.2714	0.2980	0.2750	0.3000	0.2785	0.3020	0.2820

Color Coordinates Measurement allowance is ± 0.005

Property of Lite-On Only

Color Spec. Table @20mA

WA1		WA2		WA3		WA4	
x	y	x	y	x	y	x	y
0.2982	0.2903	0.3003	0.2937	0.3023	0.2973	0.3043	0.3007
0.2970	0.2930	0.2990	0.2965	0.3010	0.3000	0.3030	0.3035
0.2990	0.2965	0.3010	0.3000	0.3030	0.3035	0.3050	0.3070
0.3003	0.2937	0.3023	0.2973	0.3043	0.3007	0.3063	0.3043
WB1		WB2		WB3		WB4	
0.2995	0.2875	0.3015	0.2910	0.3035	0.2945	0.3055	0.2980
0.2982	0.2903	0.3003	0.2937	0.3023	0.2973	0.3043	0.3007
0.3003	0.2937	0.3023	0.2973	0.3043	0.3007	0.3063	0.3043
0.3015	0.2910	0.3035	0.2945	0.3055	0.2980	0.3075	0.3015
WC1		WC2		WC3		WC4	
0.3008	0.2848	0.3028	0.2883	0.3048	0.2918	0.3068	0.2952
0.2995	0.2875	0.3015	0.2910	0.3035	0.2945	0.3055	0.2980
0.3015	0.2910	0.3035	0.2945	0.3055	0.2980	0.3075	0.3015
0.3028	0.2883	0.3048	0.2918	0.3068	0.2952	0.3088	0.2988
WD1		WD2		WD3		WD4	
0.3020	0.2820	0.3040	0.2855	0.3060	0.2890	0.3080	0.2925
0.3008	0.2848	0.3028	0.2883	0.3048	0.2918	0.3068	0.2952
0.3028	0.2883	0.3048	0.2918	0.3068	0.2952	0.3088	0.2988
0.3040	0.2855	0.3060	0.2890	0.3080	0.2925	0.3100	0.2960
WE1		WE2		WE3		WE4	
0.3020	0.2820	0.3040	0.2855	0.3060	0.2890	0.3080	0.2925
0.3033	0.2793	0.3053	0.2828	0.3072	0.2862	0.3092	0.2898
0.3053	0.2828	0.3072	0.2862	0.3092	0.2898	0.3112	0.2932
0.3040	0.2855	0.3060	0.2890	0.3080	0.2925	0.3100	0.2960
MA1		MA2		MA3		MA4	
x	y	x	y	x	y	x	y
0.3063	0.3043	0.3083	0.3077	0.3103	0.3113	0.3123	0.3147
0.3050	0.3070	0.3070	0.3105	0.3090	0.3140	0.3110	0.3175
0.3070	0.3105	0.3090	0.3140	0.3110	0.3175	0.3130	0.3210
0.3083	0.3077	0.3103	0.3113	0.3123	0.3147	0.3143	0.3183
MB1		MB2		MB3		MB4	
0.3075	0.3015	0.3095	0.3050	0.3115	0.3085	0.3135	0.3120
0.3063	0.3043	0.3083	0.3077	0.3103	0.3113	0.3123	0.3147
0.3083	0.3077	0.3103	0.3113	0.3123	0.3147	0.3143	0.3183
0.3095	0.3050	0.3115	0.3085	0.3135	0.3120	0.3155	0.3155
MC1		MC2		MC3		MC4	
0.3088	0.2988	0.3108	0.3022	0.3128	0.3058	0.3148	0.3092
0.3075	0.3015	0.3095	0.3050	0.3115	0.3085	0.3135	0.3120
0.3095	0.3050	0.3115	0.3085	0.3135	0.3120	0.3155	0.3155
0.3108	0.3022	0.3128	0.3058	0.3148	0.3092	0.3168	0.3128
MD1		MD2		MD3		MD4	
0.3100	0.2960	0.3120	0.2995	0.3140	0.3030	0.3160	0.3065
0.3088	0.2988	0.3108	0.3022	0.3128	0.3058	0.3148	0.3092
0.3108	0.3022	0.3128	0.3058	0.3148	0.3092	0.3168	0.3128
0.3120	0.2995	0.3140	0.3030	0.3160	0.3065	0.3180	0.3100
ME1		ME2		ME3		ME4	
0.3100	0.2960	0.3120	0.2995	0.3140	0.3030	0.3160	0.3065
0.3112	0.2932	0.3132	0.2968	0.3152	0.3002	0.3172	0.3038
0.3132	0.2968	0.3152	0.3002	0.3172	0.3038	0.3192	0.3072
0.3120	0.2995	0.3140	0.3030	0.3160	0.3065	0.3180	0.3100

Color Coordinates Measurement allowance is ± 0.005

Property of Lite-On Only

Typical Electrical / Optical Characteristics Curves (25°C Ambient Temperature Unless Otherwise Noted)

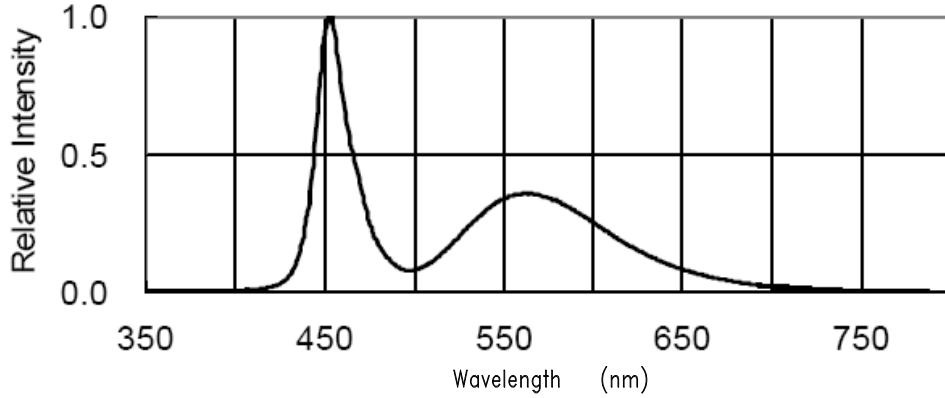

Fig.1 RELATIVE INTENSITY VS. WAVELENGTH

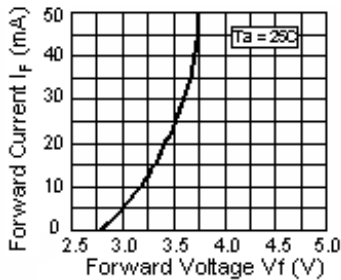

Fig.2 Forward Current vs. Forward Voltage

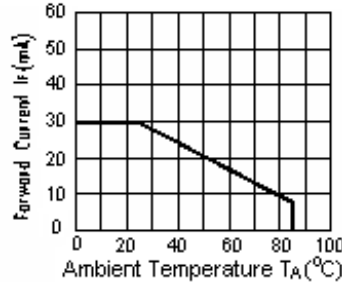

Fig.3 Forward Current Derating Curve

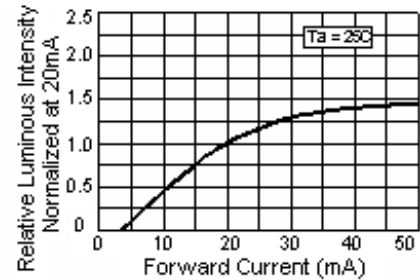

Fig.4 Relative Luminous Intensity vs. Forward Current

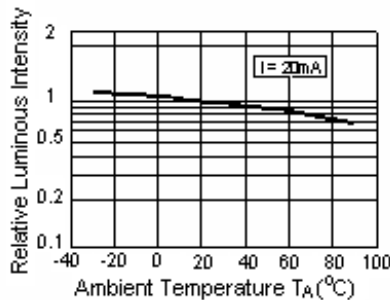

Fig.5 Luminous Intensity vs. Ambient Temperature

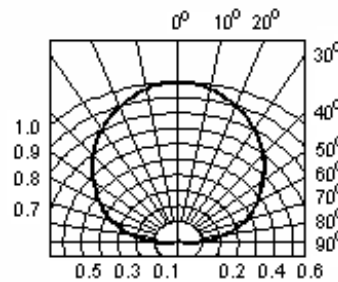

Fig.6 Spatial Distribution

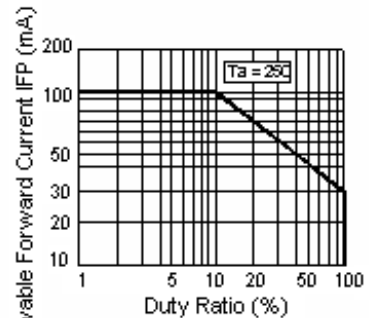

Fig.7 Duty Ratio vs. Allowable Forward Current

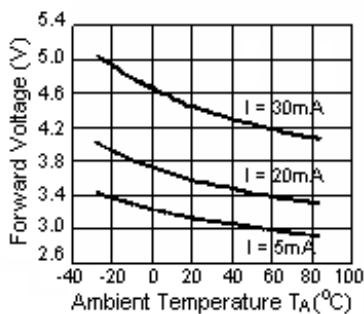

Fig.8 Ambient Temperature vs. Forward Voltage

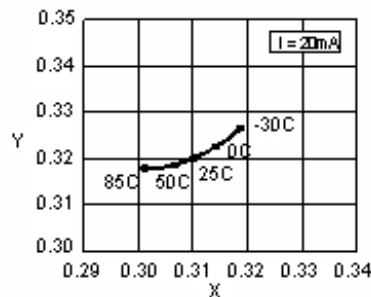

Fig.9 Ambient Temperature vs. Chromaticity Coordinate

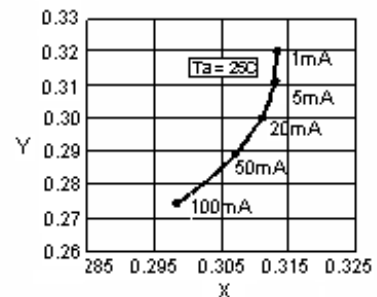

Fig.10 Forward Current vs. Chromaticity Coordinate

User Guide

Cleaning

Do not use unspecified chemical liquid to clean LED they could harm the package.
If cleaning is necessary, immerse the LED in ethyl alcohol or isopropyl alcohol at normal temperature for less one minute.

Recommend Printed Circuit Board Attachment Pad

Infrared / vapor phase

Reflow Soldering

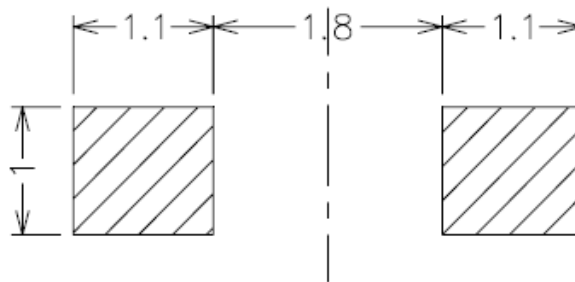

Soldering patterns

Package Dimensions of Tape

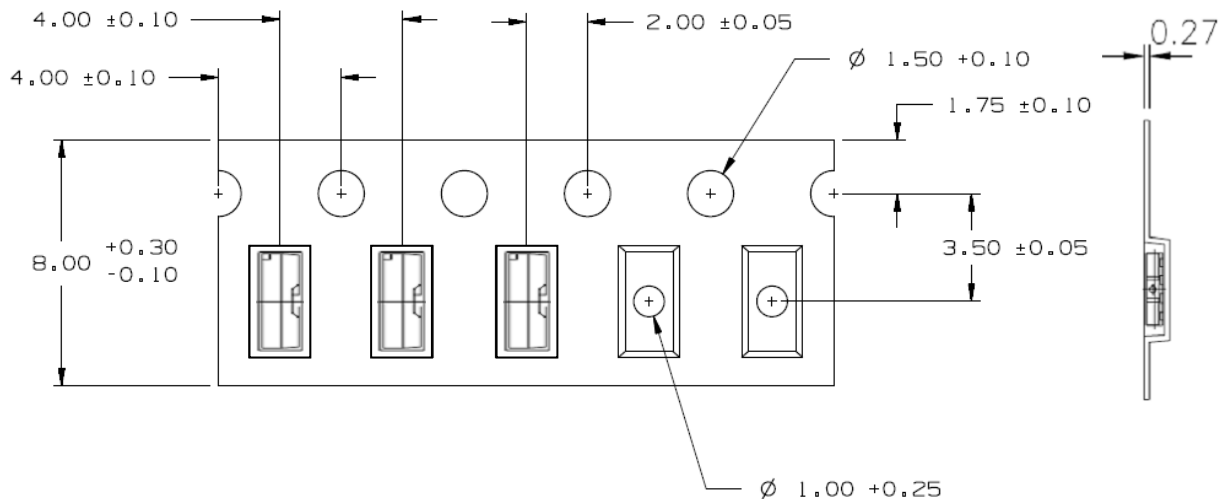

Note: 1.All dimensions are in millimeters (inches).

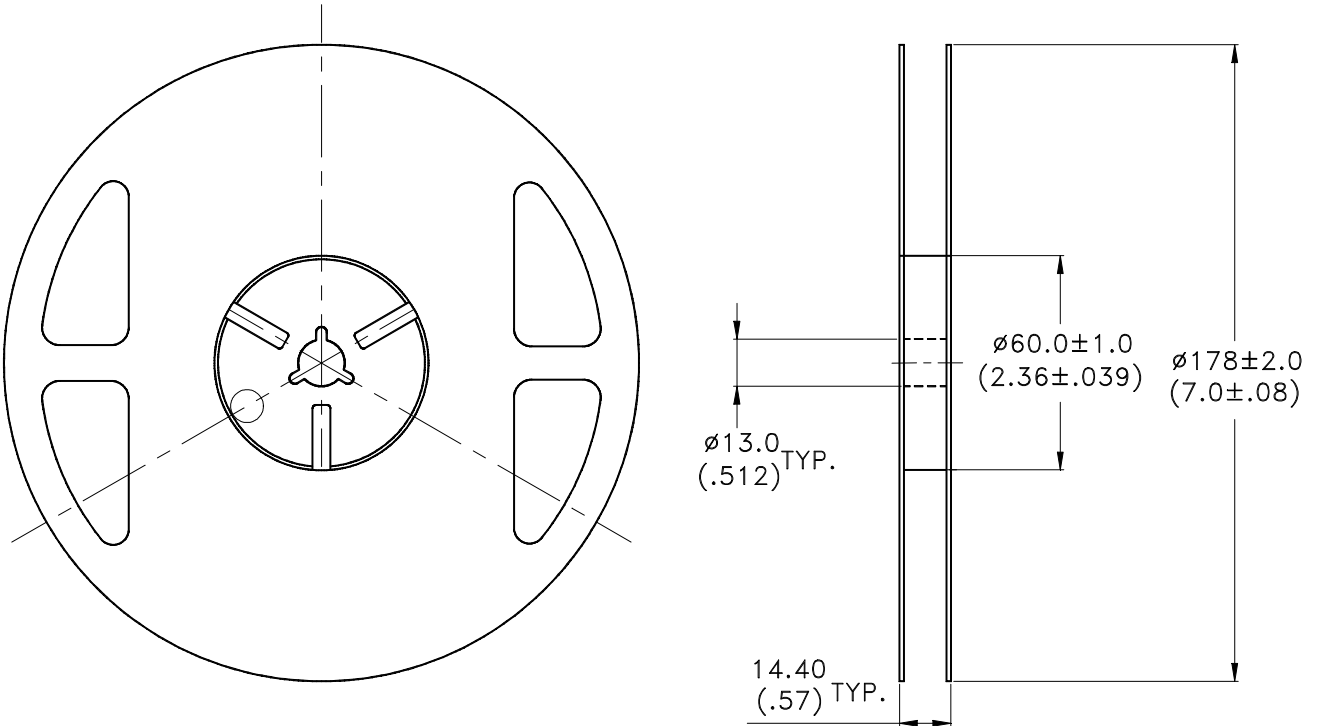
Package Dimensions of Reel**Notes:**

1. Empty component pockets sealed with top cover tape.
2. 7 inch reel-2000 pieces per reel.
3. The maximum number of consecutive missing lamps is two.
4. In accordance with EIA-481-1-B specifications.
5. Vacate 20 cm (min) on start of packing tape and vacate 50 cm (min) on last of packing tape.

CAUTIONS

1. Application

The LEDs described here are intended to be used for ordinary electronic equipment (such as office equipment, communication equipment and household applications). Consult Liteon's Sales in advance for information on applications in which exceptional reliability is required, particularly when the failure or malfunction of the LEDs may directly jeopardize life or health (such as in aviation, transportation, traffic control equipment, medical and life support systems and safety devices).

2. Storage

This product is qualified as Moisture sensitive Level 3 per JEDEC J-STD-020 Precaution when handling this moisture sensitive product is important to ensure the reliability of the product.

The package is sealed:

The LEDs should be stored at 30°C or less and 90%RH or less. And the LEDs are limited to use within one year, while the LEDs is packed in moisture-proof package with the desiccants inside.

The package is opened:

The LEDs should be stored at 30°C or less and 60%RH or less. Moreover, the LEDs are limited to solder process within 168hrs. If the Humidity Indicator shows the pink color in 10% even higher or exceed the storage limiting time since opened, that we recommended to baking LEDs at 60°C at least 48hrs. To seal the remainder LEDs return to package, it's recommended to be with workable desiccants in original package.

3. Cleaning

Use alcohol-based cleaning solvents such as isopropyl alcohol to clean the LED if necessary.

4. Soldering

Recommended soldering conditions:

Reflow soldering		Soldering iron	
Pre-heat	120~150°C	Temperature	300°C Max.
Pre-heat time	120 sec. Max.	Soldering time	3 sec. Max.
Peak temperature	260°C Max.		(one time only)
Soldering time	30 sec. Max.		

5. Drive Method

An LED is a current-operated device. In order to ensure intensity uniformity on multiple LEDs connected in parallel in an application, it is recommended that a current limiting resistor be incorporated in the drive circuit, in series with each LED as shown in Circuit A below.

Circuit model A

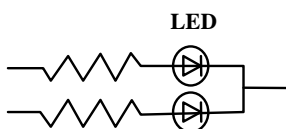

(A) Recommended circuit.

Circuit model B

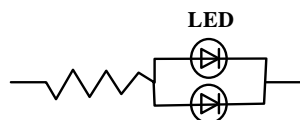

(B) The brightness of each LED might appear different due to the differences in the I-V characteristics of those LEDs.

6. ESD (Electrostatic Discharge)

Static Electricity or power surge will damage the LED.

Suggestions to prevent ESD damage:

Property of Lite-On Only

- Use of a conductive wrist band or anti-electrostatic glove when handling these LEDs.
- All devices, equipment, and machinery must be properly grounded.
- Work tables, storage racks, etc. should be properly grounded.
- Use ion blower to neutralize the static charge which might have built up on surface of the LED's plastic lens as a result of friction between LEDs during storage and handling.

ESD-damaged LEDs will exhibit abnormal characteristics such as high reverse leakage current, low forward voltage, or “ no lightup ” at low currents.

To verify for ESD damage, check for “ lightup ” and Vf of the suspect LEDs at low currents.

The Vf of “ good ” LEDs should be >2.0V@0.1mA for InGaN product

7. Reliability Test

No	Items	Temperature	Humidity	Other condition	Hrs	Times	Sampling	Criteria for judgment	
		(°C)	(%)					LED brightness @ 20mA	Vf @ 20mA
1	High temperature storage	100		-----	1000		30	>70%	<110%
2	Temperature humidity storage	60	90	-----	1000		30	>70%	<110%
3	Low temp Storage	-40		-----	1000		30	>70%	<110%
4	Steady State Operating Life Condition 1	25		IF =20mA	1000		30	>70%	<110%
5	Steady State Operating Life Condition 2	25		IF =30mA	500		30	>70%	<110%
6	Steady State Operating Life of High Temperature	85		IF =20mA	500		30	>70%	<110%
7	Steady State Operating Life of High Humidity Heat	60	90	IF =20mA	500		30	>70%	<110%
8	Steady State Operating Life of Low Temperature	-30		IF =20mA	1000		30	>70%	<110%
9	On/Off testing	60	Room Humidity	IF =20mA 10secON /10secOFF 35000 circular Continue	195		30	>50%	<110%
10	Thermal Shock	-----	-----	-30°C ~ 85°C 0.5hr. 0.5hr		200 cycles	30	>70%	<110%
11	Thermal Cycle	[1]	[1]	[1]	152 hours/2 cycles	1	30	>70%	<110%
12	Resistance to Soldering Heat (Reflow Soldering)			TSId = 260°C, 10sec.		2	30	< ±5%	< ±5%
13	Vibration ^[3]	Room Temp	Room Humidity	Random, 1.5Grms, 10~200Hz, for 30 min changeable vibration per circular X,Y,Z 3 directions	30 min /time	1	30	Go or not Go	

[1] The thermal profile is shown below

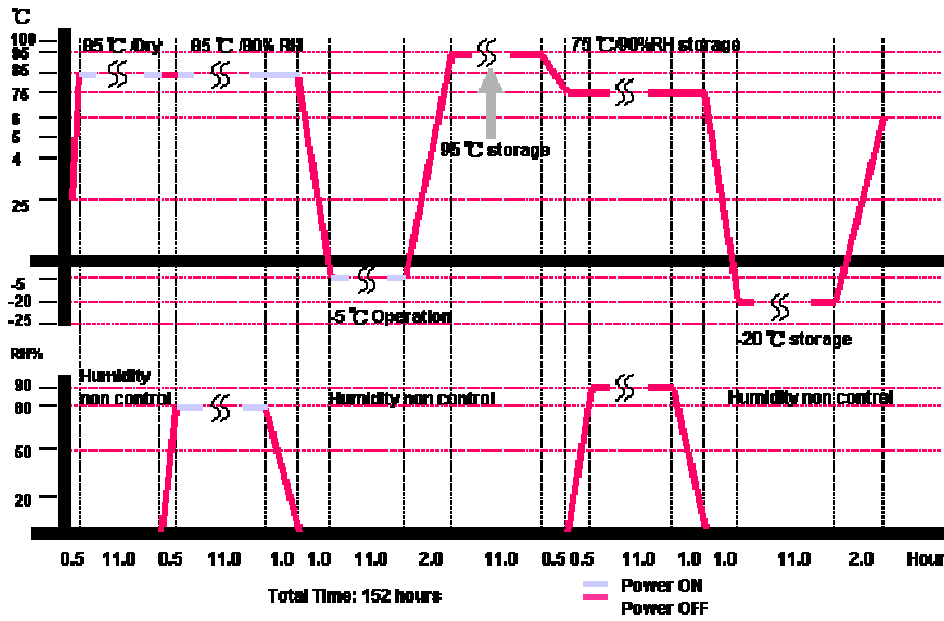

8. Estimated Life time

Item	Test Condition	Min.	Typ.	Max.	Unit
Life time(*1)	Ta=60°C IF=20mA Tj ≤ 70°C (*2)	10000	-	-	hrs

(*1)Life time means that estimated time to 50% degradation of initial luminous intensity.

(*2)Using testing circuit board:

Test board dimension: 25x25x1 mm³ (L x W x H)

Material: FR4

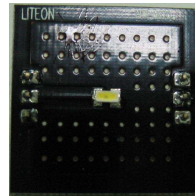

9. Others

The appearance and specifications of the product may be modified for improvement without prior notice.

10. Suggested Checking List

Training and Certification

1. Everyone working in a static-safe area is ESD-certified?
2. Training records kept and re-certification dates monitored?

Static-Safe Workstation & Work Areas

1. Static-safe workstation or work-areas have ESD signs?
2. All surfaces and objects at all static-safe workstation and within 1 ft measure less than 100V?
3. All ionizer activated, positioned towards the units?
4. Each work surface mats grounding is good?

Personnel Grounding

1. Every person (including visitors) handling ESD sensitive (ESDS) items wear wrist strap, heel strap or conductive shoes with conductive flooring?
2. If conductive footwear used, conductive flooring also present where operator stand or walk?
3. Garments, hairs or anything closer than 1 ft to ESD items measure less than 100V*?
4. Every wrist strap or heel strap/conductive shoes checked daily and result recorded for all DLs?
5. All wrist strap or heel strap checkers calibration up to date?

Note: *50V for Blue LED.

Device Handling

1. Every ESDS items identified by EIA-471 labels on item or packaging?
2. All ESDS items completely inside properly closed static-shielding containers when not at static-safe workstation?
3. No static charge generators (e.g. plastics) inside shielding containers with ESDS items?
4. All flexible conductive and dissipative package materials inspected before reuse or recycle?

Others

1. Audit result reported to entity ESD control coordinator?
2. Corrective action from previous audits completed?
3. Are audit records complete and on file?