

## Product Specification

### Multi-rate CWDM Pluggable SFP Transceiver

#### FWLF15217Dxx

#### PRODUCT FEATURES

- Up to 2.67 Gb/s bi-directional data links
- Hot-pluggable SFP footprint
- Built-in digital diagnostic functions
- Uncooled DFB laser transmitter in 8 possible CWDM wavelengths
- Duplex LC connector
- Very low jitter
- Metal enclosure, for lower EMI
- Single 3.3V power supply
- Low power dissipation
- Operating temperature range: 0°C to 70°C



#### APPLICATIONS

- Metro Access Rings and Point-to-Point networking for SONET, Gigabit Ethernet and Fibre Channel

Finisar's FWLF15217Dxx CWDM Small Form Factor Pluggable (SFP) transceivers are designed for operation in Metro Access Rings and Point-to-Point networks using SONET<sup>1</sup>Gigabit Ethernet<sup>2</sup> and Fibre Channel<sup>3</sup> networking equipment. They are available in eight different CWDM wavelengths and comply with ITU CWDM standard<sup>4</sup>. Digital diagnostics functions can be accessed via an I<sup>2</sup>C serial bus. In addition, the transceivers comply with the Small Form Factor Pluggable Multi-Sourcing Agreement (MSA)<sup>5</sup> are RoHS and lead free compliant per Directive 2002/95/EC<sup>6</sup> and Finisar Application Note AN-2038<sup>7</sup>.

#### PRODUCT SELECTION

Wavelength	xx	Clasp Color Code	Wavelength	xx	Clasp Color Code
1470 nm	47	Gray	1550 nm	55	Yellow
1490 nm	49	Violet	1570 nm	57	Orange
1510 nm	51	Blue	1590 nm	59	Red
1530 nm	53	Green	1610 nm	61	Brown

## I. Pin Descriptions

Pin	Symbol	Name/Description	Ref.
1	V <sub>EET</sub>	Transmitter Ground (Common with Receiver Ground)	1
2	T <sub>FAULT</sub>	Transmitter Fault. Not supported.	
3	T <sub>DIS</sub>	Transmitter Disable. Laser output disabled on high or open.	2
4	MOD_DEF(2)	Module Definition 2. Data line for Serial ID.	3
5	MOD_DEF(1)	Module Definition 1. Clock line for Serial ID.	3
6	MOD_DEF(0)	Module Definition 0. Grounded within the module.	3
7	Rate Select	No connection required	4
8	LOS	Loss of Signal indication. Logic 0 indicates normal operation.	5
9	V <sub>EER</sub>	Receiver Ground (Common with Transmitter Ground)	1
10	V <sub>EER</sub>	Receiver Ground (Common with Transmitter Ground)	1
11	V <sub>EER</sub>	Receiver Ground (Common with Transmitter Ground)	1
12	RD-	Receiver Inverted DATA out. AC Coupled	
13	RD+	Receiver Non-inverted DATA out. AC Coupled	
14	V <sub>EER</sub>	Receiver Ground (Common with Transmitter Ground)	1
15	V <sub>CCR</sub>	Receiver Power Supply	
16	V <sub>CCT</sub>	Transmitter Power Supply	
17	V <sub>EET</sub>	Transmitter Ground (Common with Receiver Ground)	1
18	TD+	Transmitter Non-Inverted DATA in. 100 ohm termination between TD+ and TD-, AC Coupled thereafter.	
19	TD-	Transmitter Inverted DATA in. See TD+	
20	V <sub>EET</sub>	Transmitter Ground (Common with Receiver Ground)	1

### Notes:

- Circuit ground is internally isolated from chassis ground.**
- Laser output disabled on T<sub>DIS</sub> >2.0V or open, enabled on T<sub>DIS</sub> <0.8V.
- Should be pulled up with 4.7k – 10kohms on host board to a voltage between 2.0V and 5.5V. MOD\_DEF(0) pulls line low to indicate module is plugged in.
- Finisar 2x receiver achieves simultaneous 1x and 2x operation without active control.
- LOS is open collector output. Should be pulled up with 4.7k – 10kohms on host board to a voltage between 2.0V and 5.5V. Logic 0 indicates normal operation; logic 1 indicates loss of signal.

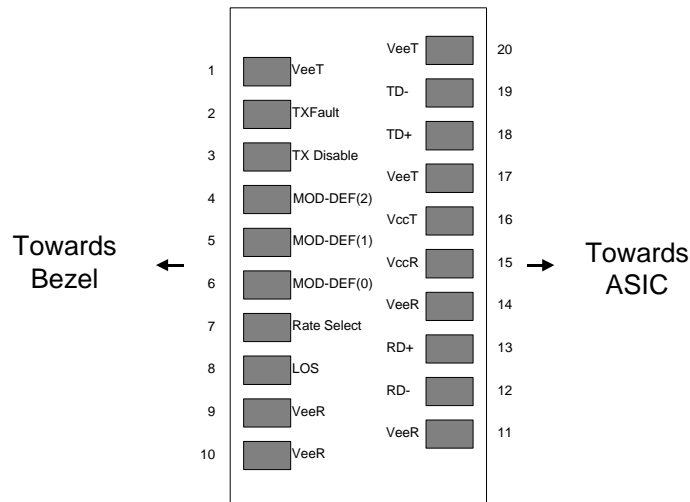

**Diagram of Host Board Connector Block Pin Numbers and Names**

**II. Absolute Maximum Ratings**

Parameter	Symbol	Min	Typ	Max	Unit	Ref.
Maximum Supply Voltage	V <sub>CC</sub>	-0.5		4.7	V	
Storage Temperature	T <sub>S</sub>	-40		85	°C	
Case Operating Temperature	T <sub>OP</sub>	0		70	°C	

**III. Electrical Characteristics (T<sub>OP</sub> = 0 to 70 °C, V<sub>CC</sub> = 3.15 to 3.60 Volts)**

Parameter	Symbol	Min	Typ	Max	Unit	Ref.
Supply Voltage	V <sub>CC</sub>	3.15		3.60	V	
Supply Current	I <sub>CC</sub>		200	300	mA	
<b>Transmitter</b>						
Input differential impedance	R <sub>in</sub>		100		Ω	1
Single ended data input swing	V <sub>in,pp</sub>	250		1200	mV	
Transmit Disable Voltage	V <sub>D</sub>	V <sub>CC</sub> – 1.3		V <sub>CC</sub>	V	
Transmit Enable Voltage	V <sub>EN</sub>	V <sub>EE</sub>		V <sub>EE</sub> + 0.8	V	2
Transmit Disable Assert Time				10	us	
<b>Receiver</b>						
Single ended data output swing	V <sub>out,pp</sub>	250		800	mV	3
Data output rise time	t <sub>r</sub>		100	175	ps	4
Data output fall time	t <sub>f</sub>		100	175	ps	4
LOS Fault	V <sub>LOS fault</sub>	V <sub>CC</sub> – 0.5		V <sub>CC</sub> <sub>HOST</sub>	V	5
LOS Normal	V <sub>LOS norm</sub>	V <sub>EE</sub>		V <sub>EE</sub> +0.5	V	5
Power Supply Rejection	PSR	100			mVpp	6

**Notes:**

1. Connected directly to TX data input pins. AC coupled thereafter.
2. Or open circuit.
3. Into 100 ohms differential termination.
4. 20% to 80 %
5. Loss Of Signal is LVTTTL. Logic 0 indicates normal operation; logic 1 indicates no signal detected.
6. Receiver sensitivity is compliant with power supply sinusoidal modulation of 20 Hz to 1.5 MHz up to specified value applied through the recommended power supply filtering network.

**IV. Low Speed Signals**

Parameter	Symbol	Min	Typ	Max	Units	Notes/Conditions
RX_LOS Assert Level		-30			dBm	
RX_LOS Deassert Level				-19	dBm	
RX_LOS Hysteresis		0.5	2		dB	
RX_LOS Assert Delay	t_loss_on			100	μsec	From detection of loss of signal to assertion of RX_LOS
RX_LOS Negate Delay	t_loss_off			100	μsec	From detection of presence of signal to negation of RX_LOS
TX_DISABLE Assert Time	t_off			10	μsec	Rising edge of TX_DISABLE to fall of output signal below 10% of nominal
TX_DISABLE Negate Time	t_on			1000	μsec	Falling edge of TX_DISABLE to rise of output signal above 90% of nominal. Time indicated is under steady-state temperature conditions.
TX_DISABLE Reset Time	t_reset	10			μsec	TX_DISABLE HIGH before TX_DISABLE set LOW
TX_FAULT Assert				100	μsec	From fault to assertion of TX_FAULT
Initialization Time				300	μsec	From power on to negation of TX_FAULT using TX_DISABLE

**V. Optical Characteristics (T<sub>OP</sub> = 0 to 70 °C, V<sub>CC</sub> = 3.15 to 3.60 Volts)**

Parameter	Symbol	Min	Typ	Max	Unit	Ref.
<b>Transmitter</b>						
Output Opt. Pwr (EOL)	P <sub>OUT</sub>	0		+5	dBm	2
Optical Wavelength	$\lambda$	(X-6.5)	(X+1)	(X+6.5)	nm	3
Wavelength Temperature Dependence			0.08	0.125	nm/°C	
Spectral Width	$\Delta\lambda_{20}$			1	nm	4
Optical Extinction Ratio	ER	8.2			dB	5
Sidemode Suppression Ratio	SMSR <sub>min</sub>	30			dB	
Optical Rise/Fall Time	t <sub>r</sub> / t <sub>f</sub>			180	ps	6
RIN	RIN			-120	dB/Hz	
Transmitter Jitter Generation				75	mUI	7
Dispersion Penalty at 50 km				1.5	dB	8
<b>Receiver</b>						
Optical Input Power	P <sub>in</sub>	-20		0	dBm	9
Optical Input Wavelength	$\lambda_C$	1450		1620	nm	
Receiver Jitter Generation				75	mUI	7
Optical Return Loss		27			dB	

**Notes:**

- Parameters are specified over temperature and voltage, at end of life unless otherwise noted.
- Class 1 Laser Safety per FDA/CDRH and IEC-825-1 regulations.
- Over case temperature of 0 to 70 °C. The Transmitter Center Wavelength “X” is as specified by the customer. The current available wavelengths are: 1470, 1490, 1510, 1530, 1550, 1570, 1590, and 1610 nm. Please see the “Product Selection” section on page 1.
- Full width, -20dB from peak.
- Measured filtered, at 2.488 Gb/s. Min represents worst-case ER over temperature and at end of life.
- Unfiltered, 20% to 80%.
- Measured per GR-253<sup>2</sup> section 5.6 for OC-48 B.
- SMF-28 fiber used. 60kms represents 1200ps/nm at 1610nm. Measured at 2.488Gb/s with a PRBS 2<sup>23</sup>-1 pattern at a BER<10<sup>-12</sup>.
- P<sub>in</sub> represents the range of input powers where BER<10<sup>-12</sup>. P<sub>in</sub> is valid over all data rates specified in Section IV.

**VI. General Specifications**

Parameter	Symbol	Min	Typ	Max	Units	Ref.
Data Rate	BR	0.155*		2.67	Gb/sec	*OC-3/12 compatible. Not compliant w/ all OC-3/12 specifications, such as min ER. (OC-48 compliance takes precedence)
Total Link Budget	--	20	22		dB	2.488 Gb/s, BER < 10 <sup>-12</sup> w/ PRBS 2 <sup>23</sup> -1. Does not include dispersion penalty

**VII. Environmental Specifications**

Parameter	Symbol	Min	Typ	Max	Units	Ref.
Case Operating Temperature	T <sub>op</sub>	0		70	°C	
Storage Temperature	T <sub>sto</sub>	-40		85	°C	

**VIII. Regulatory Compliance**

Finisar CWDM SFP transceivers are Class 1 Laser Products. They are certified per the following standards:

Feature	Agency	Standard
Laser Eye Safety	FDA/CDRH	CDRH and IEC-825 Class 1 Laser Product. See Note 1
Laser Eye Safety	TÜV	EN 60950 EN 60825-1 EN 60825-2
Electrical Safety	CSA	CLASS 3862.07 CLASS 3862.87

Note 1: Complies with FDA performance standards for laser products except for deviations pursuant to Laser Notice No. 50, dated July 26, 2001.

## IX. Digital Diagnostic Functions

All Finisar SFPs support the 2-wire serial communication protocol outlined in the SFP MSA<sup>5</sup>. These SFPs use an Atmel AT24C01A 128 byte E<sup>2</sup>PROM with an address of A0h (see table below for E<sup>2</sup>PROM contents). For details on interfacing with the E<sup>2</sup>PROM, see the Atmel data sheet titled “AT24C01A/02/04/08/16 2-Wire Serial CMOS E<sup>2</sup>PROM.”<sup>8</sup>

Finisar’s CWDM SFPs also support extended diagnostic features as described in Finisar Applications Note AN-2030, “Digital Diagnostic Monitoring Interface for Optical Transceivers”<sup>9</sup>, and additional information is available in SFF standard titled: “Digital Diagnostic Monitoring Interface for Optical Transceivers”<sup>10</sup> (SFF-8472 rev9.3). A controller IC that monitors system parameters such as laser current, module temperature, transmitter power, and received power is accessible at address A2H.

I2C clock speed, digital diagnostic accuracy and digital diagnostic range can be found in the table below. Values in the table represent the worst-case values over temperature, voltage, and life.

Parameter	Symbol	Min	Typ	Max	Units	Notes/Conditions
I <sup>2</sup> C Clock Speed		0		100,000	Hz	Bus can be driven blind
<b>Accuracy</b>						
Internal Transceiver Temperature	DD <sub>Temperature</sub>	-3		+3	°C	Measured at controller IC
Internal Transceiver Supply Voltage	DD <sub>Voltage</sub>	-3		+3	%	Measured at controller IC
Tx Bias Current	DD <sub>Bias</sub>	-10		+10	%	
Tx Output Power	DD <sub>TxPower</sub>	-3		+3	dB	100% tested in production tested at room temp to ±2 dB
Received Average Power	DD <sub>RxPower</sub>	-3		+3	dB	100% tested in production tested at room temp to ±2 dB
<b>Range</b>						
Internal Transceiver Temperature	DD <sub>Temperature</sub>	-40		85	°C	
Internal Transceiver Supply Voltage	DD <sub>Voltage</sub>	3.0		4.0	V	
Tx Bias Current	DD <sub>Bias</sub>	0		90	mA	
Tx Output Power	DD <sub>TxPower</sub>	-10		5	dBm	
Received Average Power	DD <sub>RxPower</sub>	-23		0	dBm	

## X. Mechanical Specifications

Finisar's Multi-rate CWDM Small Form Factor Pluggable (SFP) transceivers are compatible with the dimensions defined by the SFP Multi-Sourcing Agreement (MSA).

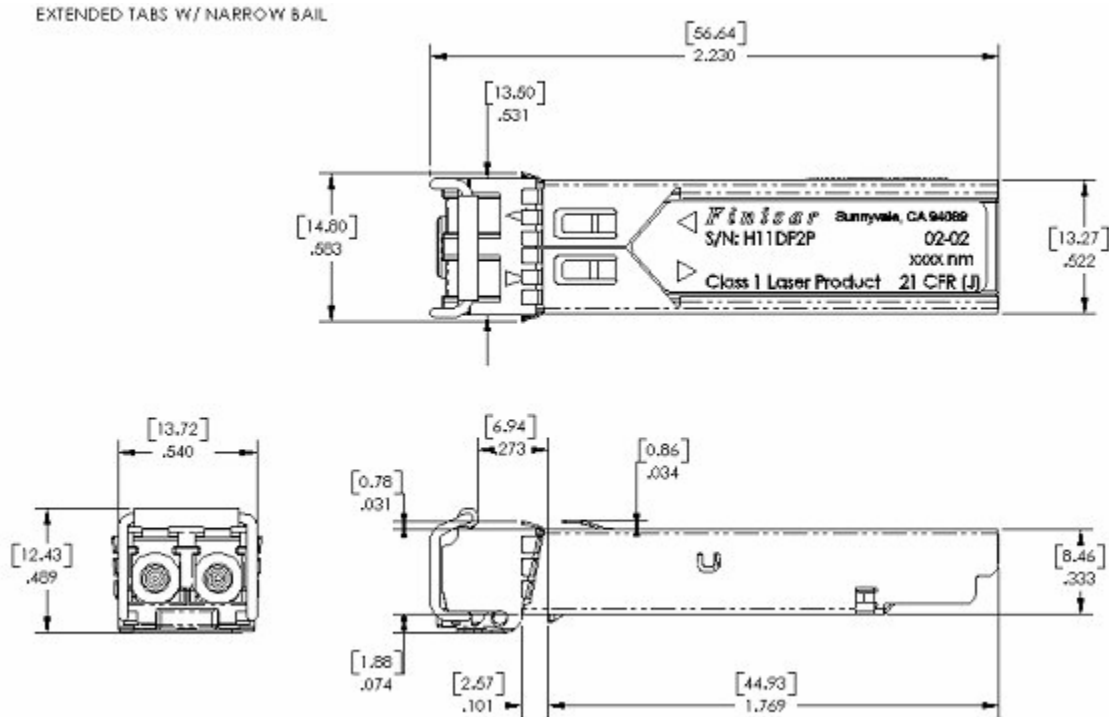

FWLF15217Dxx Outline Drawing - units in inches [mm]





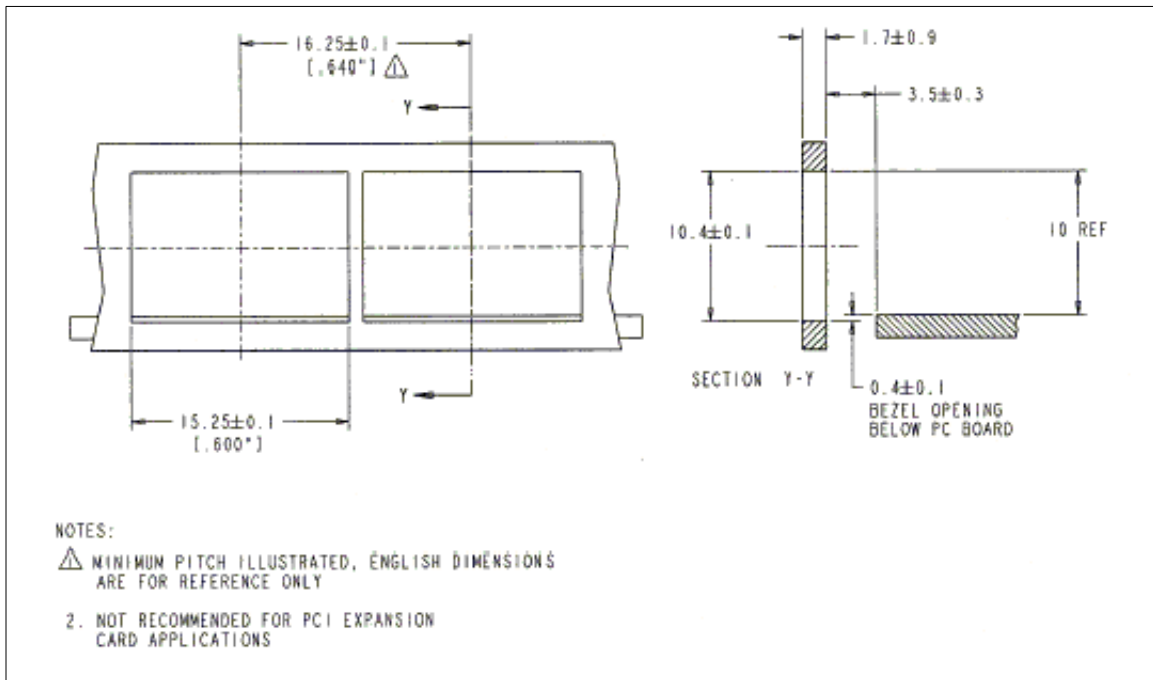
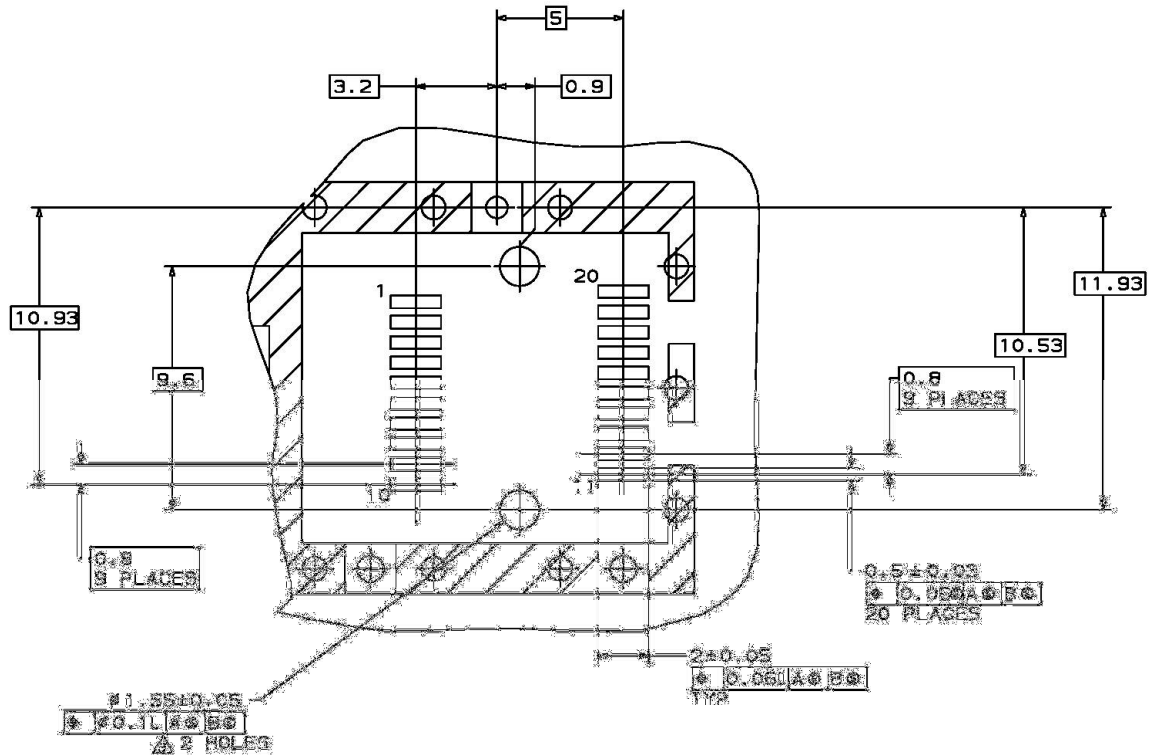

## **XII. References**

1. “SONET Transport Systems: Common Generic Criteria”, Telcordia Technologies, GR-253-CORE, Issue 3, Sept 2000.
2. IEEE Std 802.3. IEEE Standards Department, 2000.<sup>(\*)</sup>
3. “Fibre Channel Draft Physical Interface Specification (FC-PI 10.0)”. American National Standard for Information Systems.<sup>(\*)</sup>
4. “Optical Interfaces for Course Wavelength Division Multiplexing Applications”, ITU-T recommendation G.695, January 2005.
5. Small Form Factor Pluggable (SFP) Transceiver Multi-Source Agreement (MSA), September 2000. Documentation is currently available at Finisar upon request.
6. Directive 2002/95/EC of the European Council Parliament and of the Council, “on the restriction of the use of certain hazardous substances in electrical and electronic equipment”. January 27, 2003.
7. “Application Note AN-2038: Finisar Implementation Of RoHS Compliant Transceivers”, Finisar Corporation, January 21, 2005.
8. “AT24C01A/02/04/08/16 2-Wire Serial CMOS E<sup>2</sup>PROM”, Atmel Corporation. [www.Atmel.com](http://www.Atmel.com)
9. “Application Note AN-2030: Digital Diagnostic Monitoring Interface for Optical Transceivers”, Finisar Corporation, April 2002.
10. “Digital Diagnostic Monitoring Interface For Optical Transceivers Rev 9.3”. SFF Document No. SFF-8472.

(\*) Neither IEEE 802.3 nor FC-PI 10.0 specifies a 1621 nm DFB single mode interface. The FWLF15217Dxx complies with these specifications except for the following optical parameters, which have different values: transmitter wavelength, extinction ratio, receiver sensitivity, and transmit output power. See Section V for details.

## **For More Information**

Finisar Corporation  
1308 Moffett Park Drive  
Sunnyvale, CA 94089-1133  
Tel. 1-408-548-1000  
Fax 1-408-541-6138  
[sales@finisar.com](mailto:sales@finisar.com)  
[www.finisar.com](http://www.finisar.com)