

2x10 SFF G-PON OLT Transceiver

FTM-9723P-KGH(G)

Members of Flexon™ Family

Standard

- ◆ Compliant with ITU-T G.984.2 Amendment 1
- ◆ Compliant with FCC 47 CFR Part 15, Class B
- ◆ Compliant with FDA 21 CFR 1040.10 and 1040.11, Class

Description

FTM-9723P-KGH(G) is Optical Line Terminal (OLT) compliant with ITU-T Rec.G.984.2 Amendment 1.

The transceiver is the high performance module for 2488.32Mbps downstream and 1244.16Mbps upstream data link in single fiber by using 1490nm continuous-mode transmitter and 1310nm burst-mode receiver.

The transmitter section uses a multiple quantum well 1490nm DFB laser and is Class I laser compliant product according to international safety standard IEC-60825.

The receiver section uses an integrated 1310nm APD (Avalanche Photo Diode) and preamplifier mounted in an optical header and limiting post-amplifier IC. Unlike the conventional burst-mode receiver, the receiver does not require reset pulse to receive optical data packets with different optical power.

The optical output can be disabled by a LVTTTL logic high-level input of TX_DIS. LAS_FAIL is provided to indicate that degradation of the laser. Signal Detected (SD) output is provided to indicate the detection of an input optical signal of receiver.

Digital diagnostic monitoring interface is incorporated into the transceivers and allows real time access to the transceiver operating parameters such as power supply, operating temperature, laser bias current, transmitter optical power by reading a built-in memory with I²C interface. Analog RSSI signal indicate the received optical power value and the calibration parameters are stored in the memory.



Features

- ◆ Single fiber bi-directional data links with asymmetric 2488.32Mbps downstream and 1244.16Mbps upstream
- ◆ Integrated with micro-optics WDM filter for dual wavelength Tx/Rx operation at 1490/1310nm
- ◆ 1490nm continuous-mode transmitter with DFB laser
- ◆ 1310nm burst-mode receiver with APD-TIA
- ◆ Optical isolator built in for extreme Return Loss tolerance
- ◆ Resetless burst-mode receiver design
- ◆ Support Class B+ attenuation range 13-28dB
- ◆ Support more than 20dB dynamic range
- ◆ 0 to 70°C operating temperature
- ◆ 2x10 SFF package with SC/UPC pigtail
- ◆ Digital diagnostic monitoring interface
- ◆ Analog RSSI (Received Signal Strength Indication) for monitoring on received optical power.
- ◆ Single 3.3V power supply
- ◆ LVPECL compatible data input/output interface
- ◆ LVTTTL transmitter disable control
- ◆ LVTTTL transmitter fault alarm
- ◆ LVTTTL receiver signal-detected indication
- ◆ Low EMI and excellent ESD protection
- ◆ Class I laser safety standard IEC-60825 compliant

Applications

- ◆ Gigabit-capable Passive Optical Networks (G-PON) – OLT side

Regulatory Compliance

The transceivers have been tested according to American and European product safety and electromagnetic compatibility regulations (See Table 1). For further information regarding regulatory certification, please refer to Flexon™ regulatory specification and safety guidelines, or contact with Fiberxon, Inc. America sales office listed at the end of documentation.

Table 1 - Regulatory Compliance

Feature	Standard	Performance
Electrostatic Discharge (ESD) to the Electrical Pins	MIL-STD-883E Method 3015.7	Class I (>500 V)
Electromagnetic Interference (EMI)	FCC Part 15 Class B EN55022 Class B (CISPR 22B) VCCI Class B	Compliant with standards
Immunity	IEC 61000-4-3	Compliant with standards
Laser Eye Safety	FDA 21CFR 1040.10 and 1040.11 EN60950, EN (IEC) 60825-1,2	Compliant with Class I laser product
Component Recognition	UL and CSA	Compliant with standards
Pigtail Integrity	GR326 and GR468	Compliant with standards

Absolute Maximum Ratings

Absolute Maximum Ratings are those values, beyond which, some damage may occur to the devices. Exposure to conditions above the Absolute Maximum Ratings listed in Table 2 may negatively impact the reliability of the products.

Table 2- Absolute Maximum Ratings

Parameter	Symbol	Min.	Max.	Unit	Note
Storage Ambient Temperature	T _{STG}	-40	85	°C	
Operating Case Temperature	T _C	0	70	°C	
Operating Humidity	H _{OPR}	5	95	%	
Power Supply Voltage	V _{CC}	0	4	V	
Input Voltage		GND	V _{CC}	V	
Receiver Damaged Threshold		0		dBm	
Soldering Temperature			400	°C	1
Bending Radius		30		mm	
Pigtail Fiber Contact Temperature			85	°C	

Note 1: Only for soldering by iron and 10 seconds on leads only

Recommended Operating Conditions

Table 3 - Recommended Operating Conditions

Parameter	Symbol	Min.	Typ.	Max.	Unit	Note
Power Supply Voltage	V _{CC}	3.13	3.3	3.47	V	3.3V±5%
Operating Case Temperature	T _C	0		70	°C	
Operating Humidity Range	H _{OPR}	5		95	%	
Data Rate(Upstream/Downstream)			1244.16/2488.32		Mbit/s	

Optical and Electrical Characteristics

Table 4 - Transmitter Optical and Electrical Characteristics (0°C <T_C<70°C and 3.13V<V_{CC}<3.47V)

Parameter	Symbol	Min.	Typ.	Max.	Unit	Note
Optical Center Wavelength	λ _C	1480		1500	nm	
Optical Spectrum Width (-20dB)	Δλ			1	nm	
Side Mode Suppression Ratio	SMSR	30			dB	
Average Launch Power (BOL)	P _{OUT}	+2.0		+5	dBm	1
Average Launch Power (EOL)		+1.5		+5	dBm	
Average Launch Power-OFF Transmitter	P _{OFF}			-39	dBm	
Extinction Ratio	ER	10			dB	2
Transmitter Eye Diagram	Compliant With ITU-T G.984.2					2,3
Optical Return Loss Tolerance				15	dB	
Optical Path Penalty	TDP			0.5	dB	4
Data Input Differential Swing	V _{IN}	200		1600	mV	5
Input Differential Impedance	Z _{IN}	90	100	110	Ω	
Power Supply Current	I _{CC_TX}			180	mA	
Transmitter Disable Voltage - Low	V _{TDIS, L}	0		0.8	V	6
Transmitter Disable Voltage - High	V _{TDIS, H}	2.0		V _{CC}	V	
Transmitter Failure Alarm Voltage - Low	V _{LFA, L}	0		0.4	V	7
Transmitter Failure Alarm Voltage - High	V _{LFA, H}	2.4		V _{CC}	V	

Note 1: Launched into 9/125um Single Mode Fiber.

Note 2: Measured with PRBS 2²³-1 plus 72bits CID test pattern@2488.32Mbit/s, and the Bessel-Thompson filter is turned on.

Note 3: Transmitter eye mask definition is shown as below.

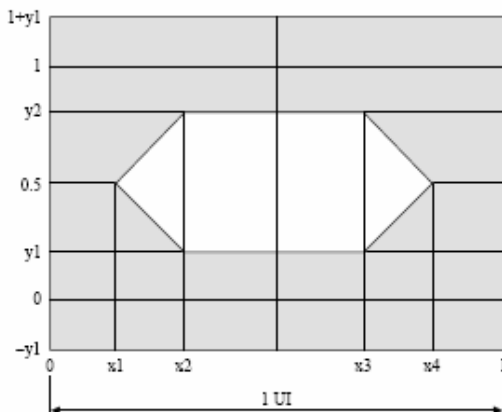

	2488.32Mbit/s
x1/x4	---
x2/x3	---
x3-x2	0.2
y1/y2	0.25/0.75

Note 4: Maximum sensitivity penalty due to transmitter and dispersion effect through 20km of SMF optical fiber.

Note 5: Compatible with LVPECL/CML input, AC coupled internally. (See [Recommended Interface Circuit](#))

Note 6: TX_DIS (See [Pin Function Definitions](#))

Note 7: LAS_FAIL (See [Pin Function Definitions](#))

Table 5 - Receiver Optical and Electrical Characteristics (0°C <T_C<70°C and 3.13V<V_{CC}<3.47V)

Parameter	Symbol	Min.	Typical	Max.	Unit	Notes
Operating Wavelength		1260		1360	nm	
Sensitivity	P _{SEN}			-28	dBm	1
Saturation	P _{SAT}	-8			dBm	
Amplitude Recovery Time	T _{RECOVERY}			1	Bit	1,2
Dynamic Range		-28		-8	dBm	1,3
Signal-Detected Assert Level	P _{SDA}			-30	dBm	4
Signal-Detected Deassert Level	P _{SDD}	-45			dBm	5
Signal-Detected Hysteresis	P _{SDA} - P _{SDD}	0.5		6	dBm	
Optical Return Loss Tolerance				10	dB	
Power Supply Current	I _{CC_RX}			250	mA	
Data Output Voltage - Low	V _{OL} -V _{CC}	-1.81		-1.62	V	6
Data Output Voltage - High	V _{OH} -V _{CC}	-1.02		-0.88	V	
Signal-Detected Voltage - Low	V _{SD,L}	0		0.4	V	7
Signal-Detected Voltage - High	V _{SD,H}	2.4		V _{CC}	V	

Note 1: Measured with Fiberxon GPON ONT and a PRBS 2²³-1 Plus 72CID test pattern @1.25Gbit/s, BER =10⁻¹⁰.

Note 2: See Figure 1,2. Measured with the Fiberxon GPON ONT and the T_{GUARD}=25.6ns

Note 3: See Figure 3. T_{RECOVERY} be less than 1 bit is guaranteed. Measured with the Fiberxon GPON ONT and the T_{GUARD}=25.6ns.

Note 4: An increase in optical power above the specified level will cause Signal-Detected (SD) output to switch from a low state to a high state.

Note 5: A decrease in optical power below the specified level will cause Signal-Detected (SD) output to switch from a high state to a low state.

Note 6: LVPECL output, DC coupled internally, guaranteed in the full range of input optical power (-8dBm to -30dBm) (See [Recommended Interface Circuit](#))

Note 7: SD (See [Pin Function Definitions](#))

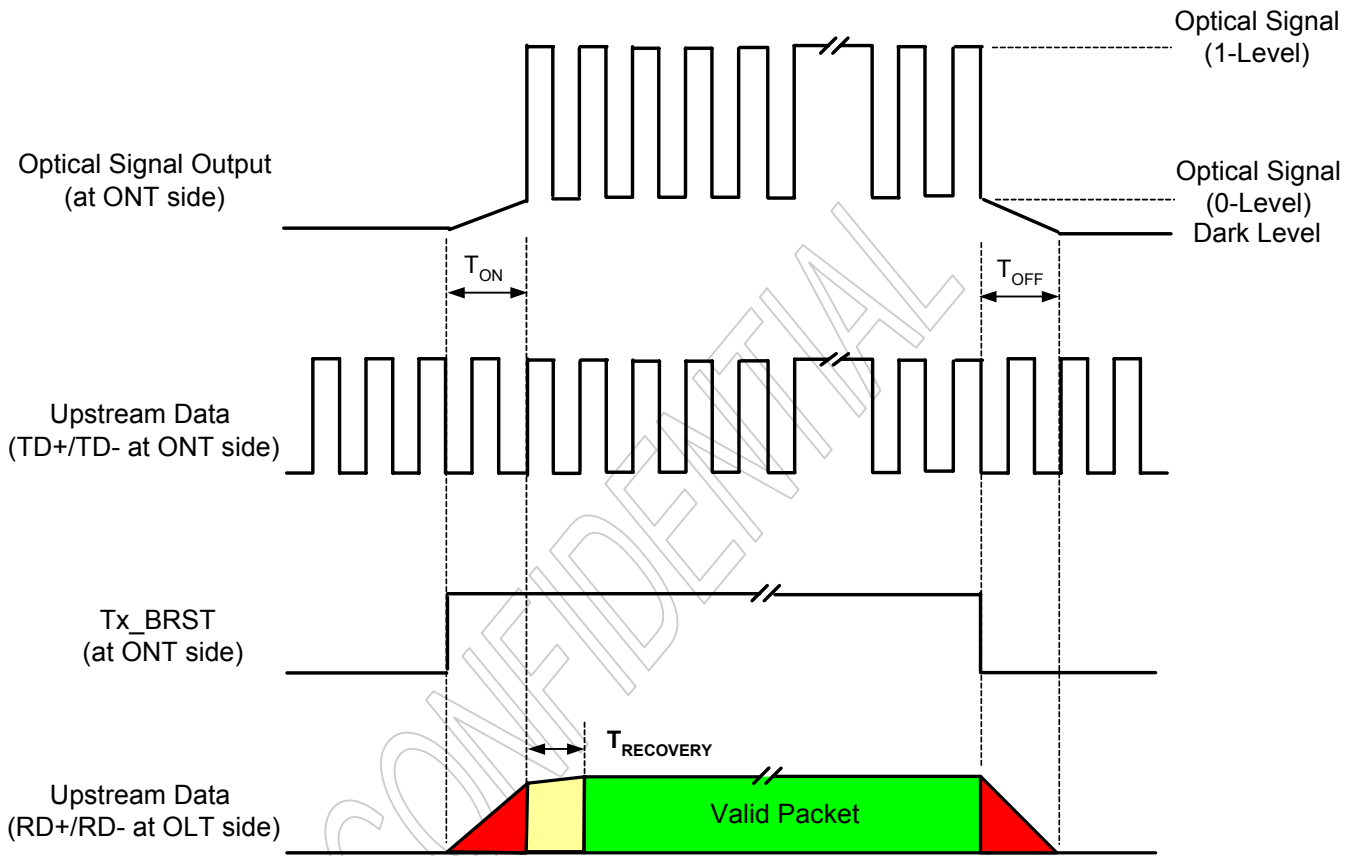

Figure 1 Timing Parameter Definition in Burst Mode Sequence (Sole ONT Application)

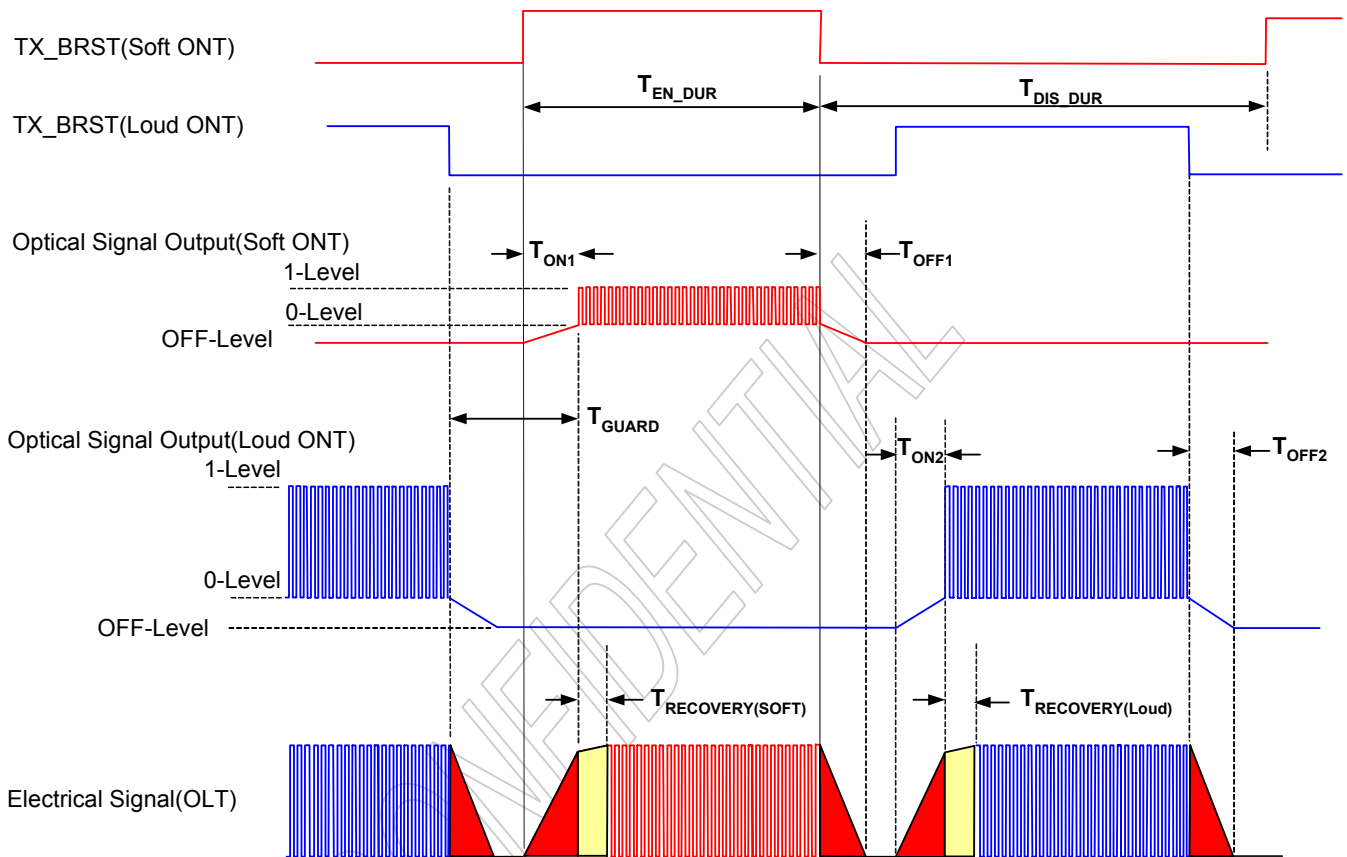

Figure 2 Timing Parameter Definitions in Burst Mode Sequence (Dual ONTs Application)

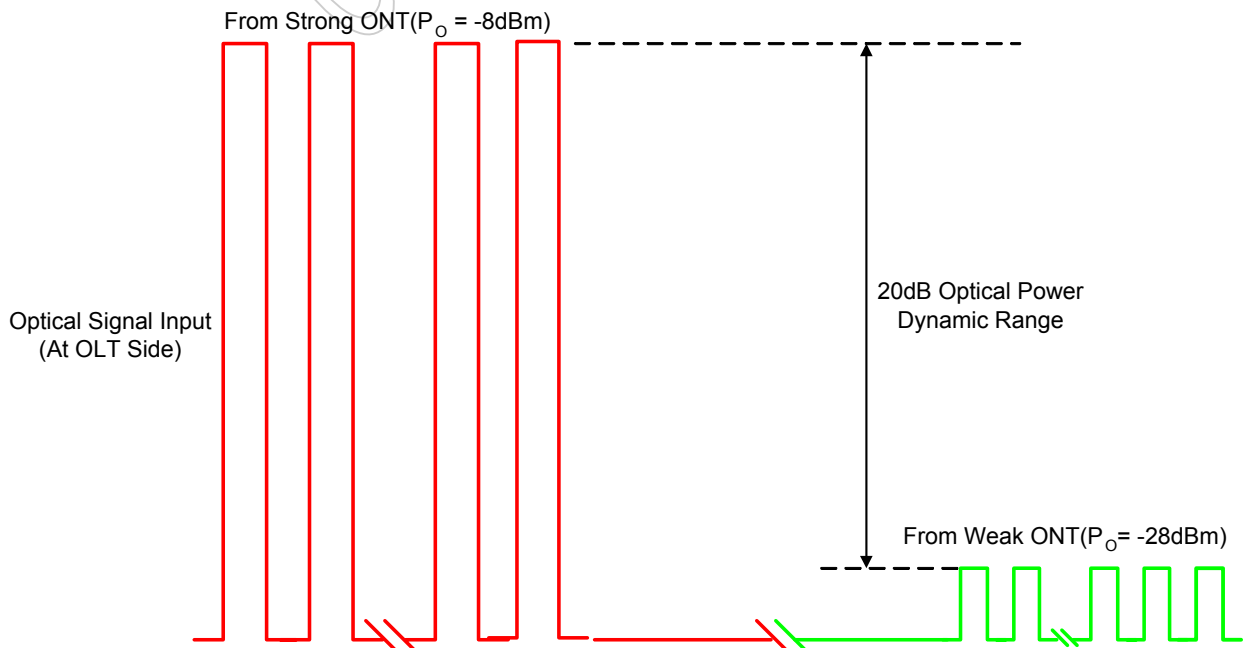

Figure 3 Burst Mode Receiver Dynamic Range in G-PON System

Recommended Interface Circuit

Figure 4 shows the recommended interface schemes.

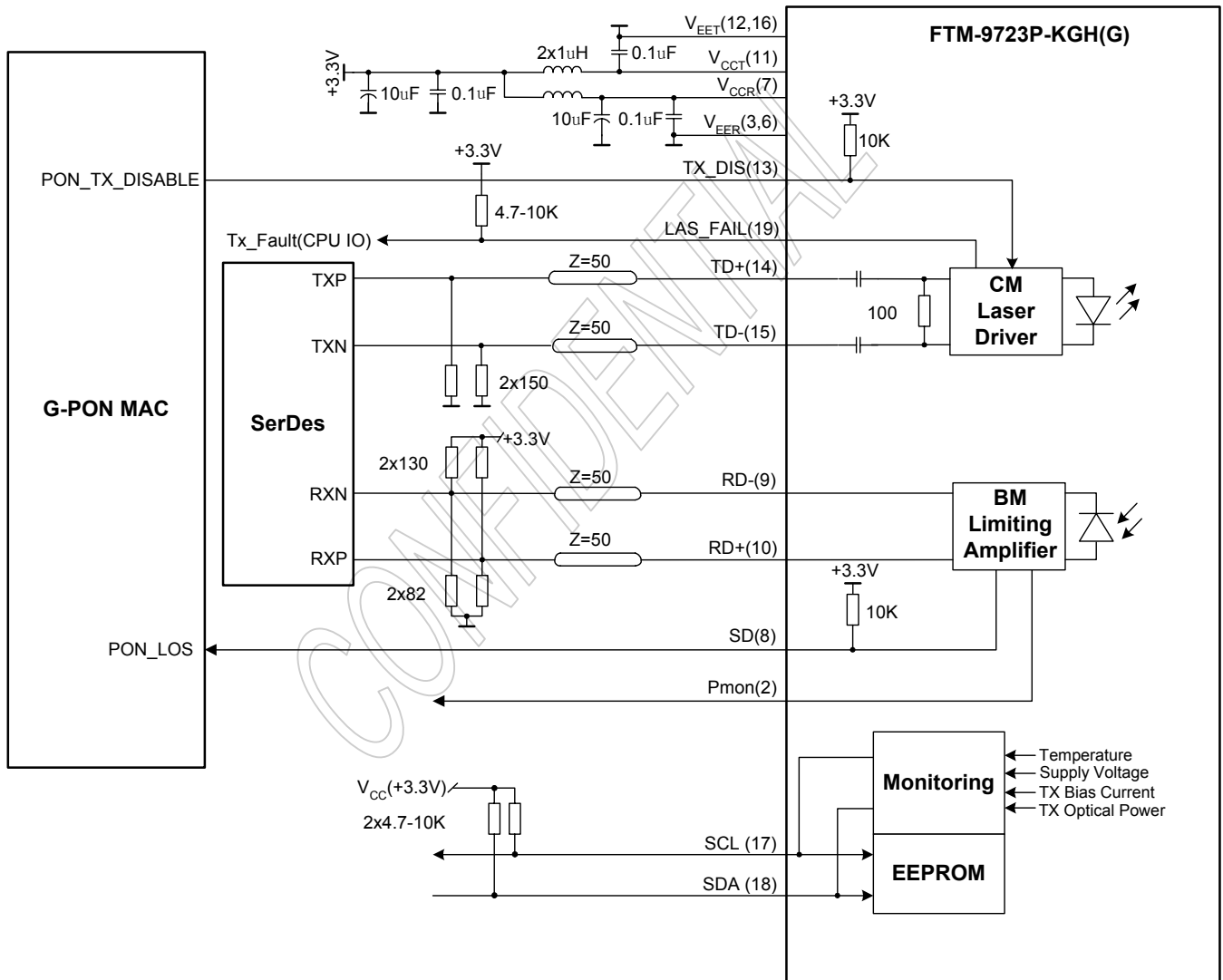

Figure 4 Recommended Interface Circuit

Pin Definitions

2X 10 SFF planform in Figure 5 below shows the pin information of electrical interface and mounting studs. Functions are described in Table 6 with some accompanying notes.

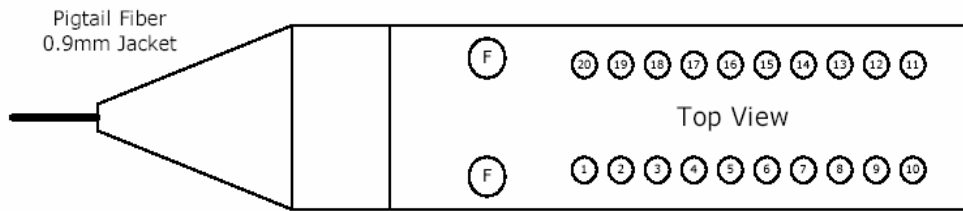

Figure 5 2×10 SFF Planform

Table 6 - Pin Function Definitions

Pin No.	Name	Description	Notes
1	NC	No Function Definition	Not connected
2	Pmon	Analog Received Optical Power Monitoring	1
3	V _{EER}	Receiver Signal Ground	
4	NC	No Function Definition	Not connected
5	NC	No Function Definition	Not connected
6	V _{EER}	Receiver Signal Ground	
7	V _{CCR}	Receiver Power Supply	
8	SD	Receiver Signal-Detected Indication	2
9	RD-	Inverted Receiver Data Output	3
10	RD+	Non-inverted Receiver Data Output	
11	V _{CCT}	Transmitter Power Supply	
12	V _{EET}	Transmitter Signal Ground	
13	TX_DIS	Transmitter Disable	4
14	TD+	Transmitter Non-inverted Data Input	5
15	TD-	Transmitter Inverted Data Input	
16	V _{EET}	Transmitter Signal Ground	
17	SCL	Clock Line of the I ² C interface	6
18	SDA	Data Line of the I ² C interface	
19	LAS_FAIL	Laser Failure Alarm Indication	7
20	NC	No Function Definition	Not connected
F	MS	Mounting Studs	8

Note 1: Analog RSSI signal indicate the received average optical power value, which is calculate by the following equation:

$$Rx_PWR(0.1\mu W) = Rx_PWR(4)*Rx_RSSI^4(mV) + Rx_PWR(3)*Rx_RSSI^3(mV) + Rx_PWR(2)*Rx_RSSI^2(mV) + Rx_PWR(1)*Rx_RSSI(mV) + Rx_PWR(0)$$

Rx_RSSI is the test value of the output RSSI signal with the unit of the millivolt; Rx_PWR(0-4) is the calibration parameters for the Rx received optical power calculation, which is stored in the EEPROM.

(See [Monitoring Specification](#))

Note 2: LVTTTL logic output, with internal 10KΩ pull-up resistor.

Optical Signal-Detected: High; Optical Signal Loss: Low

Note 3: LVPECL logic output, DC coupled internally (See [Recommended Interface Circuit](#))

Note 4: LVTTTL logic input, with internal 10KΩ pull-up resistor.

Transmitter Disabled: High; Transmitter Enabled: Low

Note 5: LVPECL logic input, AC coupled with internal termination (See [Recommended Interface Circuit](#))

Note 6: I²C interface, they should be pulled up with two 4.7K-10KΩ resistors on the host board.

Note 7: TTL logic output, pulled up by a 4.7-10KΩ resistor on the host board.

Laser Normal State: Low; Laser Failure State: High

Note 8: The mounting studs are provided for transceiver mechanical attachment to circuit board. They may also provide an optional connection of the transceiver to the equipment chassis ground. The holes in the circuit board must be tied to chassis ground. It is not recommended that the mounting studs be connected to signal ground.

Mechanical Design Outline

The form factor is 2X10 SFF with pigtail fiber. The pigtail fiber has a length of 520 - 550mm and 30mm minimum bending radius. The fiber connector type is SC/UPC. The mechanical design diagram is shown in Figure 6. (Dimension in mm)

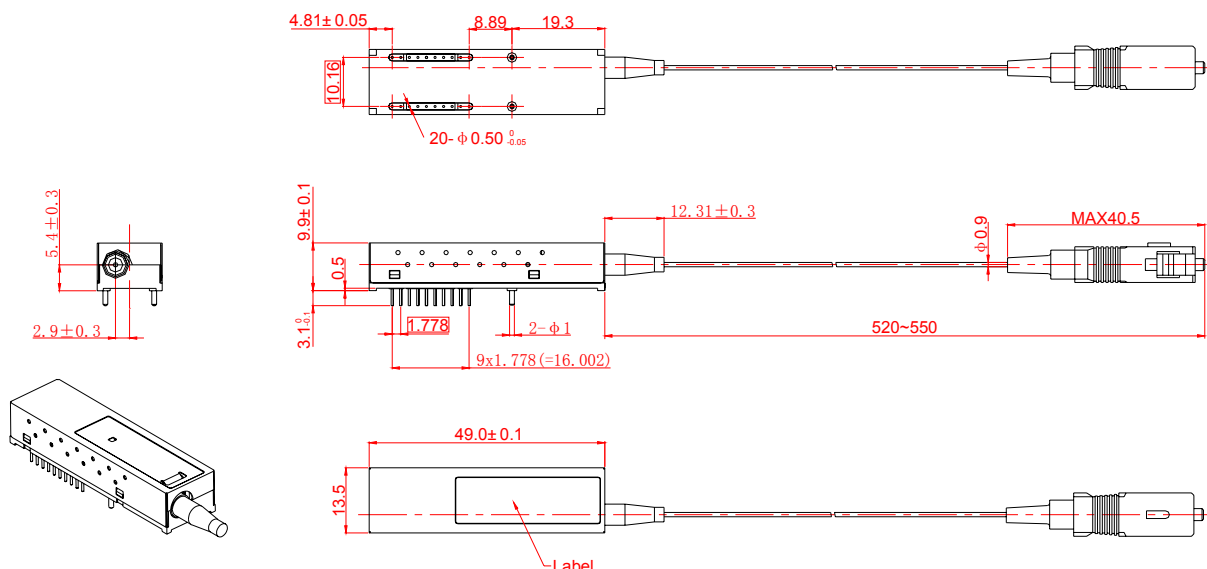

Figure 6 Mechanical Design Outline

Table 7- Pigtail Fiber Characteristics

Parameter	Min.	Typical	Max.	Unit
Mode Field Diameter		9		μm
Cladding Diameter		125		μm
Jacket Diameter		0.9		mm
Bending Radius of Pigtail Fiber	30			mm
Tension Force on Pigtail Fiber			1	Kg
Pigtail Fiber Length	520		550	mm
Optical Return Loss (SC/UPC type) -1490nm	50			dB

EEPROM Information

The SFP MSA defines a 256-byte memory map in EEPROM describing the transceiver's capabilities, standard interfaces, manufacture, and other information, which is accessible over a 2 wire serial interface at the 8-bit address 1010000X(A0h). The memory contents refer to Table 8.

Table 8 – EEPROM Serial ID Memory Contents(A0h)

Addr.	Field Size (Bytes)	Name of Field	Hex	Description
0	1	Identifier	02	Module soldered to motherboard
1	1	Ext. Identifier	04	MOD4
2	1	Connector	0B	Optical pigtail
3-10	8	Transceiver	XX XX XX XX XX XX XX XX	(Transmitter Code, not defined for G-PON)
11	1	Encoding	03	NRZ
12	1	BR, Nominal	19	2488.32Gbps transmission
13	1	Reserved	00	
14	1	Length (9um)-km	14	20(km)
15	1	Length (9um)	C8	200(100m)
16	1	Length (50um)	00	Not Support MMF
17	1	Length (62.5um)	00	Not Support MMF
18	1	Length (Copper)	00	Not Support Copper
19	1	Reserved	00	
20-35	16	Vendor name	46 49 42 45 52 58 4F 4E 20 49 4E 43 2E 20 20 20	"FIBERXON INC." (ASCII)
36	1	Reserved	00	
37-39	3	Vendor OUI	00 00 00	
40-55	16	Vendor PN	46 54 4D 2D 39 37 32 33 50 2D 4B 47 48 20 20 20	"FTM-9723P-KGH" (ASCII)
			46 54 4D 2D 39 37 32 33 50 2D 4B 47 48 47 20 20	"FTM-9723P-KGHG" (ASCII)
56-59	4	Vendor Rev	XX XX 20 20	ASCII("31 30 20 20" means 1.0 Revision)
60-61	2	Wavelength	05 D2	1490nm Laser Wavelength
62	1	Reserved	00	
63	1	CC_BASE	XX	Check sum of byte 0-62
64-65	2	Options	00 1A	LOS, TX_FAULT and TX_DISABLE
66	1	BR, max	00	
67	1	BR, min	00	
68-83	16	Vendor SN	XX XX XX XX XX XX XX XX XX XX XX XX XX XX XX XX	ASCII
84-91	8	Date code	XX XX XX XX XX XX 20 20	Year(2 bytes),Month(2 bytes),Day(2 bytes)

92	1	Diagnostic Monitoring Type	58	Compliant with SFF-8472 V9.5 Externally Calibrated Received power measurement type -Average Power
93	1	Enhanced Options	A0	Diagnostics (Optional Alarm/warning flags) Soft TX_FAULT monitoring implemented
94	1	SFF-8472 Compliance	02	Diagnostics Compliance(SFF-8472 V9.5)
95	1	CC_EXT	XX	Check sum of byte 64-94
96-255	64	Vendor Specific		

Monitoring Specification

The digital diagnostic monitoring interface defines 256-byte memory map in EEPROM, which makes use of the 8 bit address 1010001X(A2h). Please see Figure 7. Table 9~11 show the EEPROM definition from 0 to 119 byte, please refer to the SFF-8472 Rev 9.5 for the data format of these tables. The monitoring specification of this product is described in Table 12.

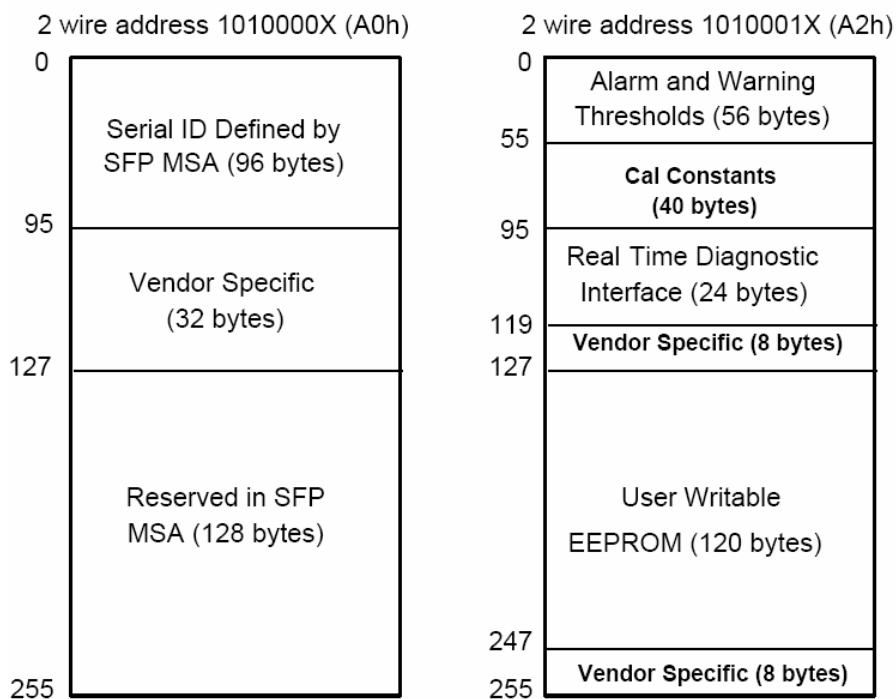

Figure 7 EEPROM Memory Map Specific Data Field Descriptions

Table 9 - EEPROM Serial ID Memory of the Alarm and Warning Thresholds Contents in A2h

Addr.	Field Size (Bytes)	Name of Field	Hex	Description
00-01	2	Temp High Alarm	55 00	85 Centigrade
02-03	2	Temp Low Alarm	FB 00	-5 Centigrade
04-05	2	Temp High Warning	50 00	80 Centigrade
06-07	2	Temp Low Warning	00 00	0 Centigrade
08-09	2	Voltage High Alarm	94 70	3.8 V
10-11	2	Voltage Low Alarm	6D 60	2.8 V
12-13	2	Voltage High Warning	8D CC	3.6 V
14-15	2	Voltage Low Warning	74 04	3.0 V
16-17	2	Bias High Alarm	75 30	60 mA
18-19	2	Bias Low Alarm	05 DC	3 mA
20-21	2	Bias High Warning	61 A8	50 mA
22-23	2	Bias Low Warning	07 D0	4 mA
24-25	2	TX Power High Alarm	9B 82	+6 dBm
26-27	2	Tx Power Low Alarm	27 10	0 dBm
28-29	2	Tx Power High Warning	7B 87	+5 dBm
30-31	2	TX Power Low Warning	31 2D	+1 dBm
32-55	24	Reserved	00 00	0

Table 10 – EEPROM Serial ID Memory of the Calibration Constants Contents in A2h

Addr.	Field Size (Bytes)	Name of Field	Hex	Description
56-59	4	Rx_PWR(4)	XX XX XX XX	Single precision floating point calibration data (various values at each device for incompatibility with “internal calibration”)
60-63	4	Rx_PWR(3)	XX XX XX XX	
64-67	4	Rx_PWR(2)	XX XX XX XX	
68-71	4	Rx_PWR(1)	XX XX XX XX	
72-75	4	Rx_PWR(0)	XX XX XX XX	
76-77	2	Tx_I(Slope)	01 00	1
78-79	2	Tx_I(Offset)	00 00	0
80-81	2	Tx_PWR(Slope)	01 00	1
82-83	2	Tx_PWR(Offset)	00 00	0
84-85	2	T (Slope)	01 00	1
86-87	2	T (Offset)	00 00	0
88-89	2	V (Slope)	01 00	1
90-91	2	V (Offset)	00 00	0
92-94	3	Reserved	00 00	0
95	1	Checksum	XX	Check sum of byte 0-94

Table 11 – EEPROM Serial ID Memory of the A/D Values and Status Bits Contents in A2h

Addr.	Bit	Name of Field	Hex	Description
96-97	7-0	Temperature	XX XX	
98-99	7-0	Vcc	XX XX	
100-101	7-0	TX Bias	XX XX	
102-103	7-0	TX Power	XX XX	
104-109	7-0	Reserved	00 00 00 00 00 00	0
110	7	TX Disable State	XX	
110	6~3	Reserved		
110	2	Laser Failure State		
110	1	Reserved		
110	0	Data_Ready_Bar		
111	7-0	Reserved	00	0
112	7	Temp High Alarm	XX	
112	6	Temp Low Alarm		
112	5	Vcc High Alarm		
112	4	Vcc Low Alarm		
112	3	TX Bias High Alarm		
112	2	TX Bias Low Alarm		
112	1	TX Power High Alarm		
112	0	TX Power Low Alarm		
113-115	7-0	Reserved	00 00 00	0
116	7	Temp High Warning	XX	
116	6	Temp Low Warning		
116	5	Vcc High Warning		
116	4	Vcc Low Warning		
116	3	TX Bias High Warning		
116	2	TX Bias Low Warning		
116	1	TX Power High Warning		
116	0	TX Power Low Warning		
117-119	0-7	Reserved	00 00 00	0

Note: The “XX” byte should be filled in according to practical case. For more information, please refer to the related document of SFF-8472 Rev 9.5.

Table 12- Monitoring Specification

Parameter	Range	Accuracy	Calibration
Temperature	-20 to 80°C	±3°C	External
Voltage	3.0 to 3.6V	±3%	External
Bias Current	0 to 100mA	±10%	External
TX Power	0 to 6dBm	±3dB	External
RX Power	-29 to -7dBm	±3dB	External

Ordering Information

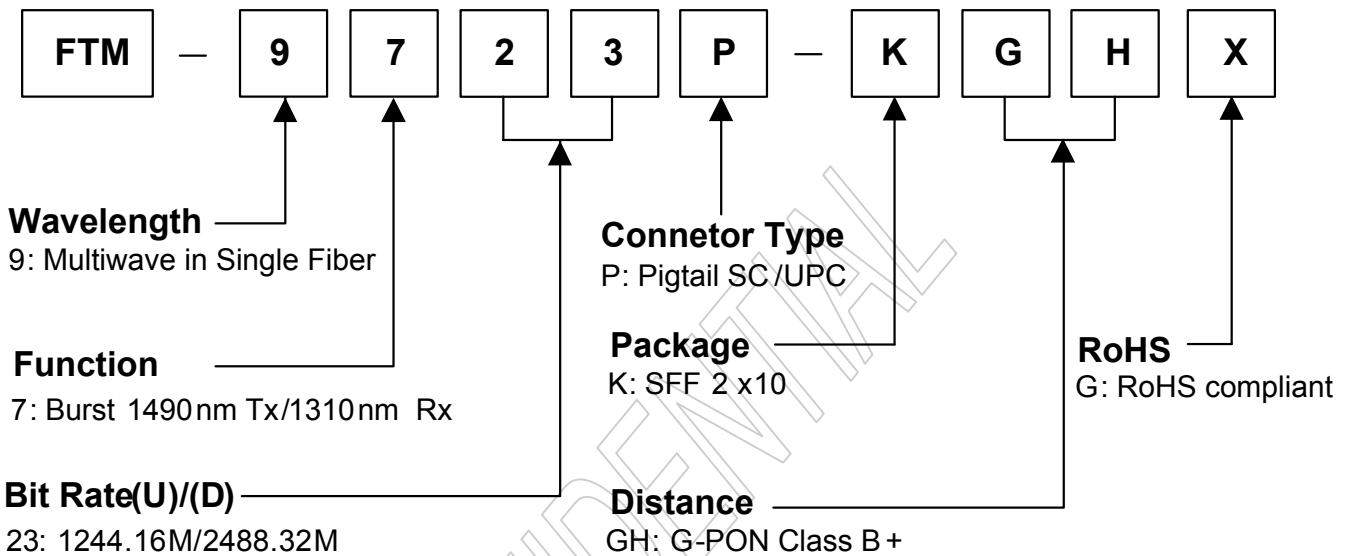

Part No.	Product Description
FTM-9723P-KGH	1490nm(TX)/1310nm(RX), SC/UPC Pigtailed 2x10 SFF for G-PON OLT Class B+ attenuation range (13-28dB), 0°C ~70°C.
FTM-9723P-KGHG	1490nm(TX)/1310nm(RX), SC/UPC Pigtailed 2x10 SFF for G-PON OLT Class B+ attenuation range (13-28dB), 0°C ~70°C, RoHS compliance

Related Documents

For further information, please refer to the following documents:

- SFF-8472 Rev 9.5
- ITU-T G984.2
- ITU-T G984.2 Amendment 1

Obtaining Document

You can visit our website:

<http://www.fiberxon.com>

Or contact with Fiberxon, Inc. America Sales Office listed at the end of documentation to get the latest documents.

Revision History

Reversion	Initiate	Review	Approve	Subject	Release Date
Pre 1a	Frank Zeng	Peter Tang	Peter Tang	Initial datasheet (temporary) (Doc No. DS3633001-1a)	Nov.18, 2005
Pre 1b	Frank Zeng	Peter Tang	Peter Tang	<ol style="list-style-type: none"> 1) Replace the Operating Ambient Temperature Spec. with the Operating Case Temperature Spec. in the Table 2~3. 2) Update the Average Launch Power, Optical Path Penalty spec. in the Table 4. 3) Update the Saturation, Sensitivity, and Dynamic Range Spec. in the Table 5; 4) Replace the Receiver Threshold Settling Time Spec. with the Amplitude Recovery Time Spec. in the Table 5. 5) Update the Power Supply Current spec. in the Table 5. 6) Update the Figure 1~3. (Doc No. DS3633001-1b) (temporary)	Dec.1, 2005
Pre 1c	Frank Zeng	Peter Tang	Peter Tang	<ol style="list-style-type: none"> 1) Modify "Transmitter Failure Alarm Voltage" in Table 4, and "Signal-Detected Voltage" in Table 5. 2) Modify Figure 1, 2. 3) Append EEPROM Serial ID Memory Contents (A0) in Table 8. (Doc No. DS3633001-1c) (temporary)	Dec.15, 2005
Pre 1d	Frank Zeng	Peter Tang	Peter Tang	Revise datasheet(temporary) Append new P/N: FTM-9723P-KGHG (Doc No. DS3633001-1d)	Jul.7, 2006

All Rights Reserved.

All information contained in this document is subject to change without notice. The products described in this document are NOT intended for use in implantation or other life support applications where malfunction may result in injury or death to persons.

The information contained in this document does not affect or change Fiberxon's product specifications or warranties. Nothing in this document shall operate as an express or implied license or indemnity under the intellectual property rights of Fiberxon or third parties. All information contained in this document was obtained in specific environments, and is presented as an illustration. The results obtained in other operating environment may vary.

THE INFORMATION CONTAINED IN THIS DOCUMENT IS PROVIDED ON AN "AS IS" BASIS. In no event will Fiberxon be liable for damages arising directly from any use of the information contained in this document.

Contact

U.S.A. Headquarter:

5201 Great America Parkway, Suite 350

Santa Clara, CA 95054

U. S. A.

Tel: 408-562-6288

Fax: 408-562-6289

Or visit our website: <http://www.fiberxon.com/>

CONFIDENTIAL