

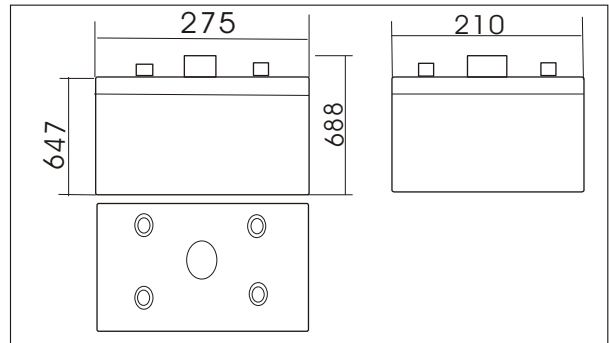

12OPzV1200(2V1200Ah)



Outer dimensions (mm)



Specifications

Nominal Voltage		2 V
Rated capacity (10 hour rate)		1200 Ah
Dimensions	Total Height	688 mm (27.1 Inches)
	Height	647mm (25.5inches)
	Length	275 mm(10.83 Inches)
	Width	210 mm (8.27inches)
Weight Approx		94Kg (206.8lbs)

Terminal Type (mm)

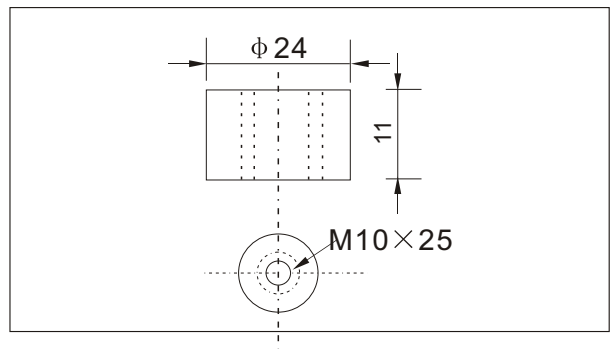

Characteristics

Capacity 25°C(77°F)	10 hourRate(120A)	1200Ah
	1 hour rate(540A)	540Ah
	0.5 hour rate(840A)	420Ah
Capacity affected by Temperature (10hour rate)	40°C(104°F)	102%
	25°C(77°F)	100%
	0°C(32°F)	85%
	-15°C(5°F)	65%
Self-Discharge at 25°C(77°F)	Capacity after 3 month storage	91%
	Capacity after 6 month storage	82%
	Capacity after 12 month storage	64%
Terminal quantity	4	
Charge (constant Voltage)	Initial Charging Current less than 240.0A Voltage 2.25-2.40V	

Discharge Curves 25°C(77°F)

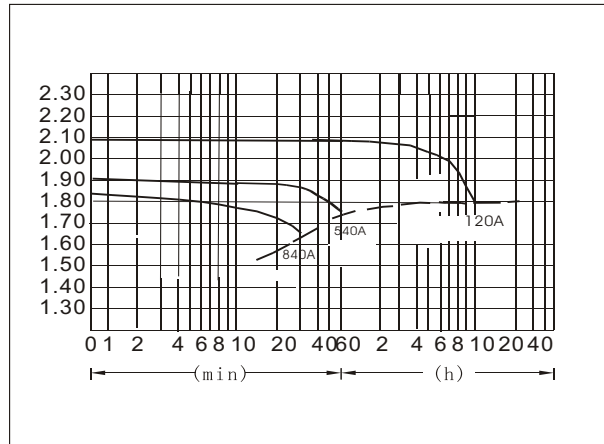

Charging characteristics(25°C)

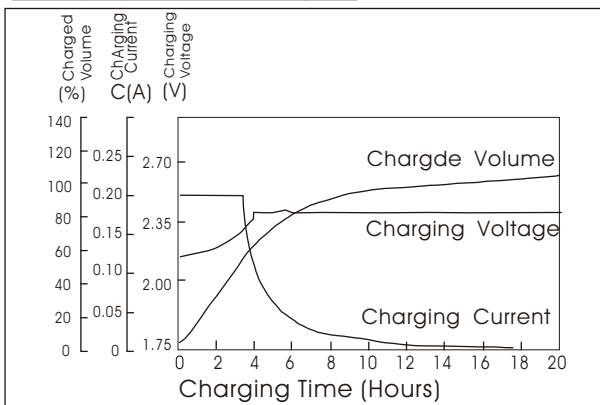

Cycling Curves

