

SGC-GC-XXB-X-XXST-XX

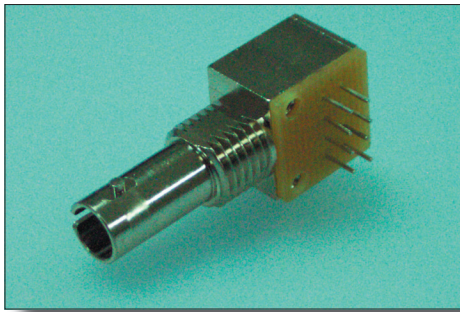

Features

- 1300nm or 1550nm Wavelength
- For Singlmode / Multimode Applications
- High Optical Power
- Low Operating Current
- High Speed
- Low Modal Noise
- 8 Pin Package with ST-A
- High Operating Temperature
- ST-A Type Sugar Cube
- For Data com Measurement Application
- RoHS Compliant available

Absolute Maximum Ratings (Tc=25°C)

Parameter	Symbol	Condition	Rating	Unit
Reverse Voltage	V_r	CW	2.5	V
Operating Current	I_{op}	CW	150	mA
Operating Temperature	T_{opr}	-	-20 ~ 70	°C
Storage Temperature	T_{stg}	-	-40 ~ 85	°C

(All optical data refer to a coupled 9/125 μ m SM & 50/125 μ m M/M fiber)

Optical and Electrical Characteristics 1300nm (Tc=25°C)

Parameter	Symbol	Min	Typ	Max	Unit	Test Conditions
Wavelength	λ	1260	1300	1340	nm	CW
Spectral Width	$\Delta\lambda$	30	-	80	nm	CW
Operating Current	I_{op}	-	80	100	mA	CW
Output Power (SM, 9/125 μ m)	P_f	10	-	40	μ W	$I_{op}=80$ mA
L		30	-	60		
M		50	-	80		
Output Power(MM, 50/125 μ m)	P_f	30	-	-	μ W	$I_{op}=80$ mA
L		50	-	-		
M		70	-	-		
Foward Voltage	V_f	-	1.2	2.0	V	CW
Rise Time	T_r	-	1.5	-	ns	
Fall Time	T_f	-	2.5	-	ns	
Output Power Variation		-	4	-	dB	25°C to 70°C

(All optical data refer to a coupled 9/125 μ m SM & 50/125 μ m M/M fiber)

Optical and Electrical Characteristics 1550nm (Tc=25°C)

Parameter	Symbol	Min	Typ	Max	Unit	Test Conditions
Peak Wavelength	λ	1510	1550	1590	nm	CW
Spectral Width(RMS)	$\Delta\lambda$	45	-	80	nm	CW
Operating Current	I_{op}	-	80	100	mA	CW
Output Power(SM, 9/125 μ m)	P_f	10	-	-	μ W	$I_{op}=80$ mA
L		20	-	-		
M		30	-	-		
Output Power(MM, 50/125 μ m)	P_f	20	-	-	μ W	$I_{op}=80$ mA
L		30	-	-		
M		40	-	-		
Foward Voltage	V_f	-	1.2	2.0	V	CW
Rise Time	T_r	-	1.5	-	ns	
Fall Time	T_f	-	2.5	-	ns	
Output Power Variation		-	4	-	dB	25°C to 70°C

SGC-GC-XXB-X-XXST-XX

Package Style : SC Type Sugar Cube Units in mm.

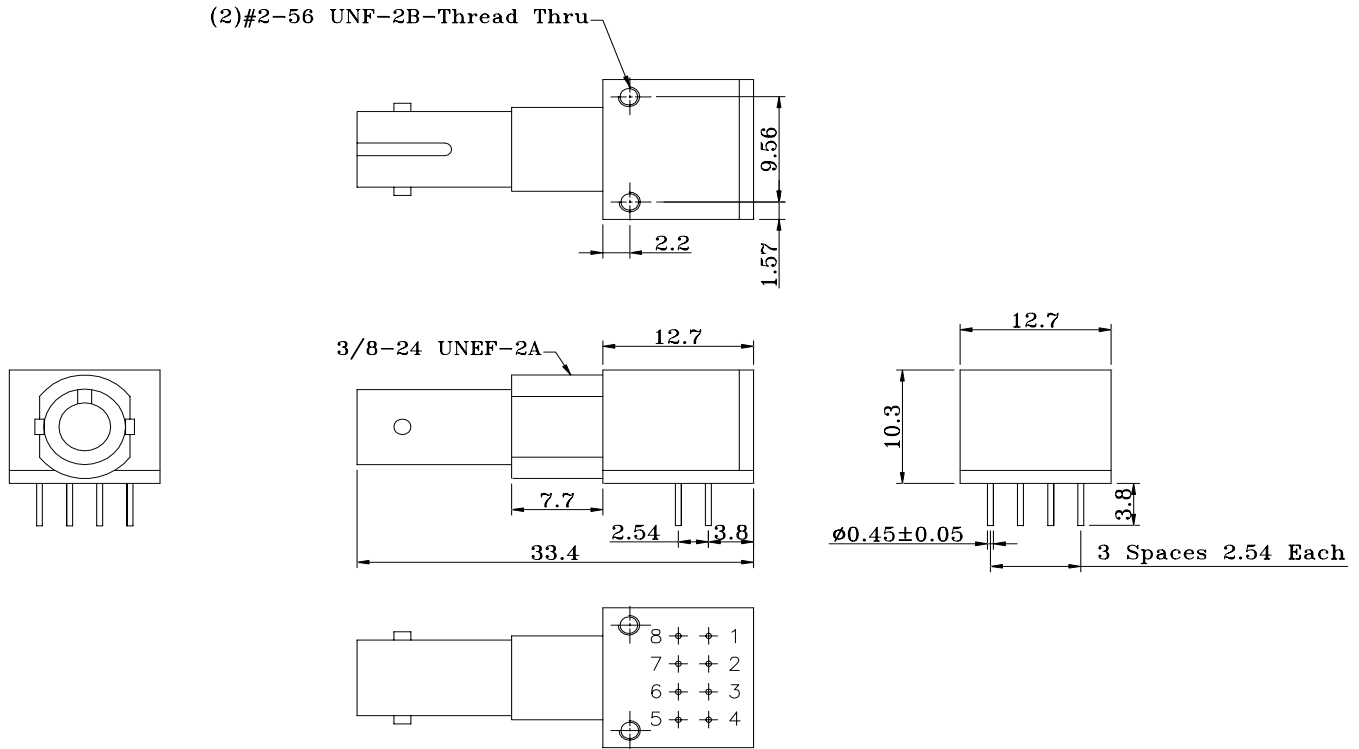

LD Pin Assignment

1:Option 1

Pin	Function
1	N/C
2	Anode
3	Cathode
4	N/C
5	N/C
6	Anode
7	Anode
8	N/C

2:Option 2

Pin	Function
1	Case GND
2	Anode
3	Cathode
4	Case GND
5	Case GND
6	Anode
7	Anode
8	Case GND

SGC-GC-XXB-X-XXST-XX

Ordering Information

SGC-GC-XXB-X-XXST-XX

Family
SGC= Sugar Cube

Application
C=CW

Tolerance
B= +/- 40nm

Pinout
1=Option 1 (Tx)
2=Option 2 (Tx)

Connector
ST=ST

Device
G=ELED (Long)

Wavelength
30:1300nm
55:1550nm

Power
L/M/H

Fiber
S = Singlemode 9/125/900um
M = Multimode 50/125/900um

RoHS Compliant
-/G5/GR

Blank = RoHS non-compliant product
G5 = RoHS 5/6-compliant product (lead exemption)
GR = Full RoHS compliant product (no exemption)

Warnings

Handling Precautions: This device is susceptible to damage as a result of electrostatic discharge (ESD). A static free environment is highly recommended. Follow guidelines according to proper ESD procedures.

Laser Safety: Radiation emitted by laser devices can be dangerous to human eyes. Avoid eye exposure to direct or indirect radiation.

Legal Notice

IMPORTANT NOTICE!

All information contained in this document is subject to change without notice, at Luminent's sole and absolute discretion. Luminent warrants performance of its products to current specifications only in accordance with the company's standard one-year warranty; however, specifications designated as "preliminary" are given to describe components only, and Luminent expressly disclaims any and all warranties for said products, including express, implied, and statutory warranties, warranties of merchantability, fitness for a particular purpose, and non-infringement of proprietary rights. Please refer to the company's Terms and Conditions of Sale for further warranty information.

Luminent assumes no liability for applications assistance, customer product design, software performance, or infringement of patents, services, or intellectual property described herein. No license, either express or implied, is granted under any patent right, copyright, or intellectual property right, and Luminent makes no representations or warranties that the product(s) described herein are free from patent, copyright, or intellectual property rights. Products described in this document are NOT intended for use in implantation or other life support applications where malfunction may result in injury or death to persons. Luminent customers using or selling products for use in such applications do so at their own risk and agree to fully defend and indemnify Luminent for any damages resulting from such use or sale.

THE INFORMATION CONTAINED IN THIS DOCUMENT IS PROVIDED ON AN "AS IS" BASIS. Customer agrees that Luminent is not liable for any actual, consequential, exemplary, or other damages arising directly or indirectly from any use of the information contained in this document. Customer must contact Luminent to obtain the latest version of this publication to verify, before placing any order, that the information contained herein is current.

© Luminent, Inc. 2005
All rights reserved