

Surface Mount Resistor

CR Series

- 0 ohm available
- Shorting links available
- 1.0 ohms to 100M ohms
- Tolerance down to 0.25%
- Solder terminations have a nickel barrier layer
- Any resistance value available within specified range

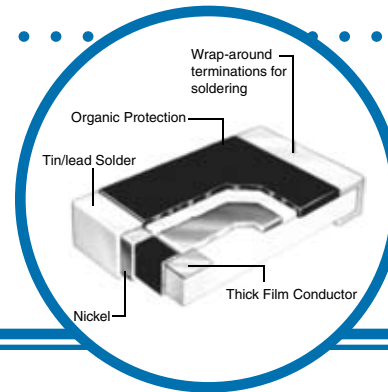

Electrical Data

IRC Type	Power Rating at 70°C (watts)	Resistance Range (ohms)					Limiting Element Voltage (volts)	TCR -55°C to +125°C (ppm/°C)	Values	Thermal Impedance** (°C/watt)	Operating Temp. Range (°C)
		5% Tol.	2% Tol.	1% Tol.	0.5% Tol.	0.25% Tol.					
CR0805	0.1	1-100M	1-50M	1-20M	1-10M	100-1M	100	<10Ω 350; 10 to 100Ω 200; 100 to 1MΩ 100; >1MΩ 250	E24 & E96 preferred (any value to order)	360	-55 to 125
CR1206	0.25	1-100M	1-50M	1-20M	1-10M	100-1M	200		200		

* For 10 devices mounted on 50x25mm p.c.b. area

** Zerohm is available

Construction:

Thick film resistor material, overglaze and organic protection are screen printed on a 96% alumina substrate.

Terminations:

Wrap-around terminations on CR resistors have good 'leach' resistance properties. They will withstand immersion in solder at 260°C for 30 seconds.

Marking:

All relevant information is recorded on the primary package or reel.

Thickness:

The thickness of these devices depend on the size of the chip. The table below shows the standard substrate thickness used (mm).

STYLE	0805	1206
Planar	0.4	0.5
Wrap-around	0.4	0.5

F = Wrap-around; G = Planar Gold.

Electrical Data

	Requirements	Actual	
		Maximum	Typical
Load at rated power: 1000 hours at 70°C	ΔR% 2 (5 above 3M3)	1	0.25
Shelf life: 12 months at room temperature	ΔR%		0.1
Derating from rated power at 70°C	zero at 125°C		
Long term damp heat	ΔR% 2	1	0.25
Temperature rapid change	ΔR% 1	0.25	
Resistance to solder heat	ΔR% 2.5	0.25	
Voltage proof	volts	500	

General Note

IRC reserves the right to make changes in product specification without notice or liability. All information is subject to IRC's own data and is considered accurate at time of going to print.

Surface Mount Resistor

Physical Data

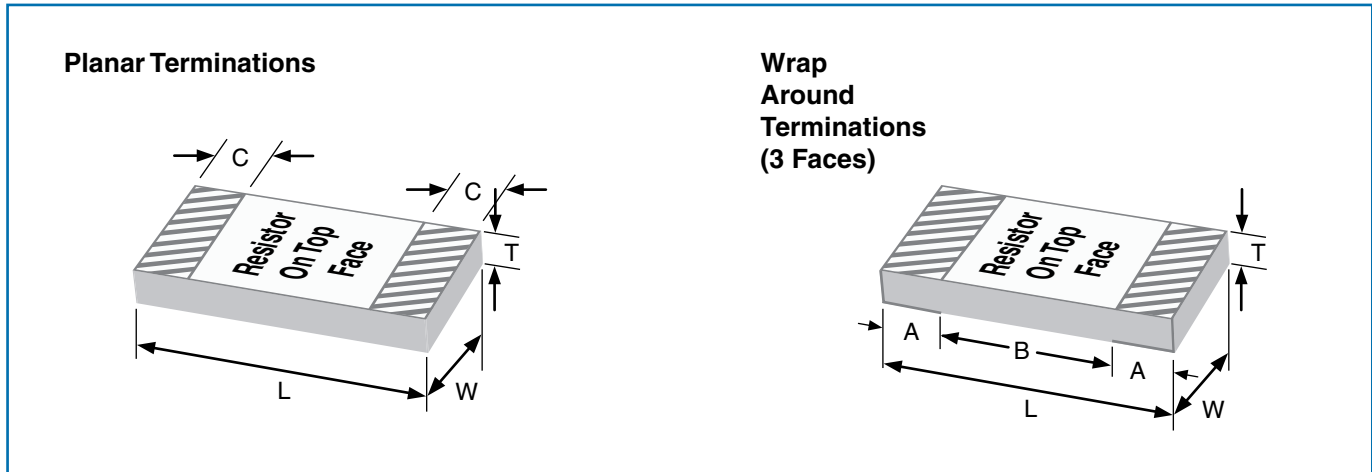

Dimensions (Inches and (mm))

Style	L	W	T	Wrap-around		Planar	Weight (g)
				A	B*	C	
0805	.079 ± .012 (2.0 ± 0.3)	.049 ± .008 (1.25 ± 0.2)	.027 (.07)	.012 ± .006 (0.3 ± 0.15)	.035 (0.9min)	.012 ± .004 (0.3 ± 0.1)	0.009
1206	.126 ± .016 (3.2 ± 0.4)	.063 ± .008 (1.6 ± 0.2)	.027 (.07)	.016 ± .008 (0.4 ± 0.2)	.067 (1.7min)	.016 ± .006 (0.4 ± 0.15)	0.020

* This dimension determines the number of conductors which may pass under the surface mounted device.

APPLICATION NOTES:

Mounting

This chip resistor is ideally suited for handling by automatic methods due to its rectangular shape and the small dimensional tolerances. Electrical connection to a ceramic substrate or to a printed circuit board can be made by reflow soldering of wrap-around terminations (e.g. suffix 'F' in CR0805F). The 'F' terminations provide good leach properties and ensure reliable contact. Due to the robust construction, the resistor chip can be immersed completely in the solder bath for 30 seconds at 260°C. This enables the resistor to be mounted on one side of a printed circuit board and other wire-leaded components on the other side.

Surface Mount Resistor



Ordering Data

Specify type, reference, etc. as indicated in this example of a CR0805F 8.2M ohms 5% resistor with wrap-around terminations and packed in a plastic bag.

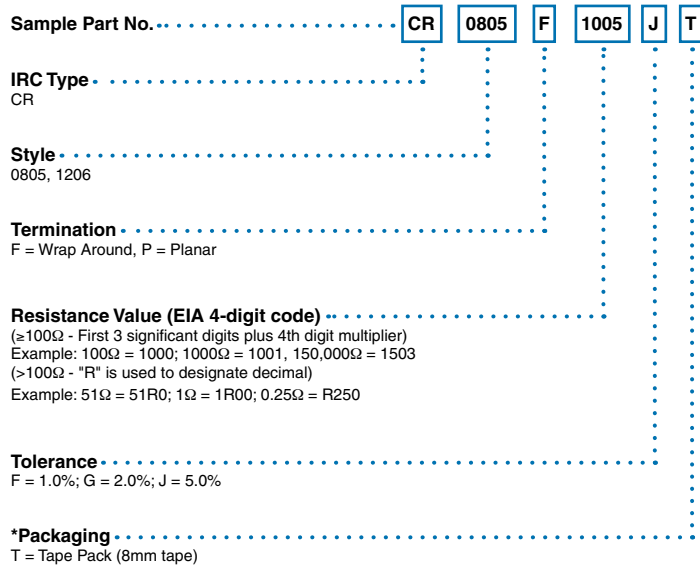

*The preferred methods of packaging are:
Gold terminated chips are packed in waffle boxes, chips with wrap-around terminations are supplied tape & reel on .8mm tape.