

PRELIMINARY SPEC

**Features**

- 0.28 INCH DIGIT HEIGHT.
- LOW CURRENT OPERATION.
- EXCELLENT CHARACTER APPEARANCE.
- EASY MOUNTING ON P.C. BOARDS OR SOCKETS.
- I.C. COMPATIBLE.
- MECHANICALLY RUGGED.
- GRAY FACE, WHITE SEGMENT.
- RoHS COMPLIANT.

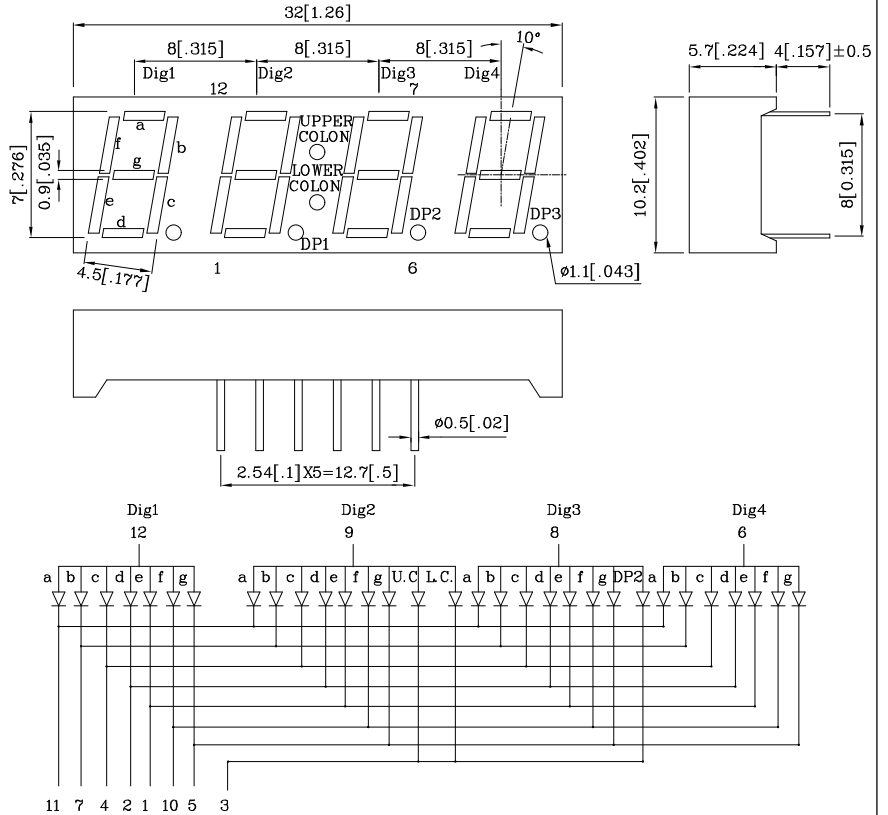

Notes:

1. All dimensions are in millimeters (inches).
2. Tolerance is  $\pm 0.25(0.01)$  unless otherwise noted.
3. Specifications are subject to change without notice.

Absolute Maximum Ratings (TA=25°C)	UY (GaAsP/ GaP)	Unit
Reverse Voltage	VR	5 V
Forward Current	IF	30 mA
Forward Current (Peak) 1/10 Duty Cycle 0.1ms Pulse Width	iFS	140 mA
Power Dissipation	PT	75 mW
Operating Temperature	TA	-40 ~ +85 °C
Storage Temperature	Tstg	-40 ~ +85 °C
Lead Solder Temperature [2mm Below Package Base]	260°C For 3 -5 Seconds	

Operating Characteristics (TA=25°C)	UY (GaAsP/ GaP)	Unit
Forward Voltage (Typ.) (IF=10mA)	VF	1.95 V
Forward Voltage (Max.) (IF=10mA)	VF	2.5 V
Reverse Current (Max.) (VR=5V)	IR	10 uA
Wavelength of Peak Emission (Typ.) (IF=10mA)	$\lambda P$	590 nm
Wavelength of Dominant Emission (Typ.) (IF=10mA)	$\lambda D$	588 nm
Spectral Line Full Width At Half-Maximum (Typ.) (IF=10mA)	$\Delta\lambda$	35 nm
Capacitance (Typ.) (VF=0V, f=1MHz)	C	20 pF

Part Number	Emitting Color	Emitting Material	Luminous Intensity (IF=10mA) ucd	Wavelength nm $\lambda P$	Description	
			min.	typ.		
DUY07A4	Yellow	GaAsP/GaP	800	2919	590	Common Anode

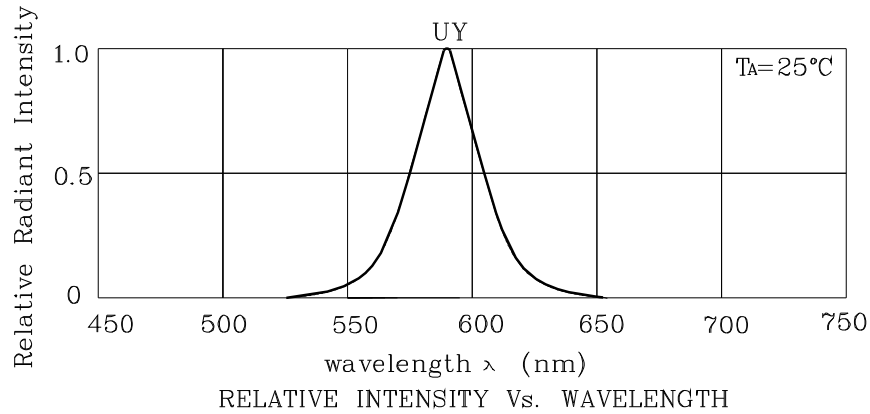

❖ UY

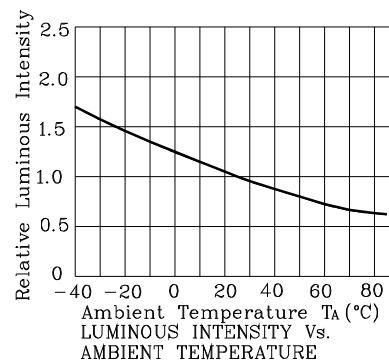
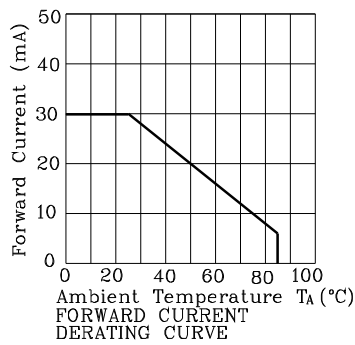
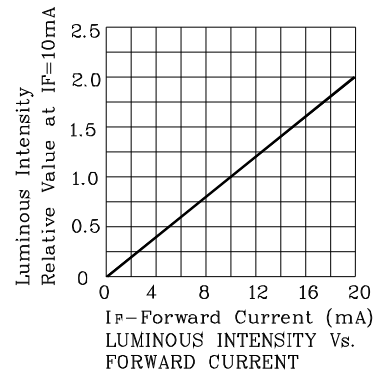
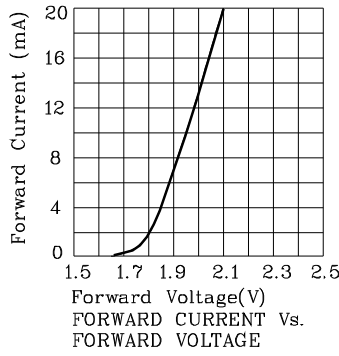

Wave Soldering Profile For Lead-free Through-hole LED.

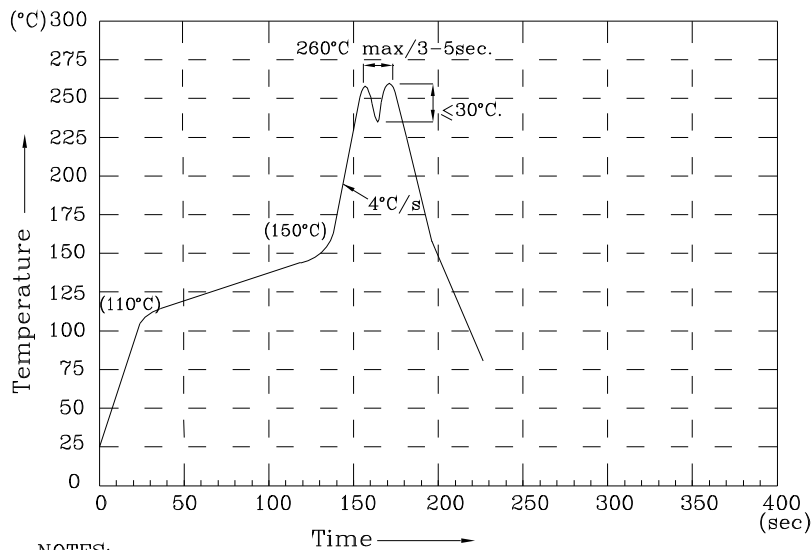

NOTES:

- 1.Recommend the wave temperature 245°C~260°C.The maximum soldering temperature should be less than 260°C.
- 2.Do not apply stress on epoxy resins when temperature is over 85 degree°C.
- 3.The soldering profile apply to the lead free soldering (Sn/Cu/Ag alloy).
- 4.No more than once.

Remarks:

If special sorting is required (e.g. binning based on forward voltage, luminous intensity/ luminous flux or wavelength), the typical accuracy of the sorting process is as follows:

1. Wavelength: +/-1nm
2. Luminous Intensity/ luminous flux: +/-15%
3. Forward Voltage: +/-0.1V

Note: Accuracy may depend on the sorting parameters.

**PACKING & LABEL SPECIFICATIONS**

**DUY07A4**

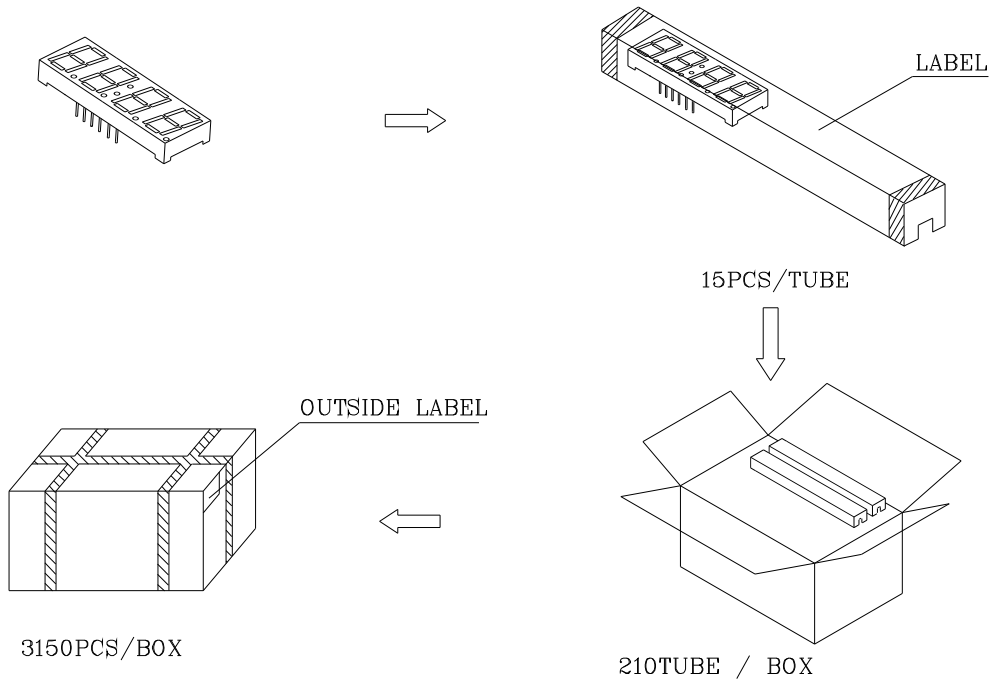

Inside LABEL Paste On The IC-tube

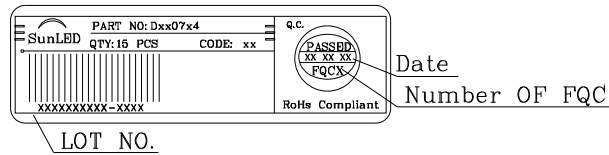

Outside LABEL Paste On The Box

